

FINAL REPORT

Grant Agreement Number: 608720
Project Acronym: Micro-FAST
Project Title: A FAST process and production system for high-throughput, highly flexible and cost-efficient volume production of miniaturised components of a wide range of materials
Funding Scheme: Collaborative Project
Date of latest version of Annex I against which the assessment will be made: 2013-05-23
Period covered from September 1st 2013 to February 28th 2017
Version number 1.0
Last date modified 28/04/2017
EC Project Officer German Esteban Muñiz
Paolo Matteazzi
Name, title and organisation of the scientific representative of the project's coordinator¹ MBN Nanomaterialia SpA
Vascon di Carbonera (TV)
31050, Treviso, Italy
Telephone +39 0422447311
E-mail research@mbn.it
Project website² address www.micro-fast.eu
Project Document Reference -
Author(s) Alberto Colella, Luca Conte (MBN, Matres) with all consortium's contribution

¹ Usually the contact person of the coordinator as specified in Art.1 of the grant agreement.

² The home page of the website should contain the generic European flag and the FP7 logo which are available in electronic format at the Europa website (logo of the European flag:

http://europa.eu/abc/symbols/emblem/index_en.htm;

logo of the 7th FP: http://ec.europa.eu/research/fp7/index_en.cfm?pg=logos). The area of activity of the project should also be mentioned.

Content

1	Executive Summary	3
2	Project Context and Main Objectives	4
3	Science and Technology Results	5
3.1	Micro-FAST press	6
3.2	In-situ micro-component robotic handling	7
3.3	Condition monitoring... Production Management System for Micro-FAST	8
3.4	Powders	9
3.5	Multiscale modelling methods	12
3.6	Tools manufacturing process	13
3.7	Surface Treatments developed for Micro-FAST tools	15
3.8	Surface coatings for Micro-FAST tools	17
3.9	Laser die-cleaning	18
3.10	Powder feeding system for micro-manufacturing applications	20
3.11	Inline forming-tool inspection	21
3.12	Ejection system	22
3.13	Manufactured demonstrators and LCA	23
4	Potential impact, main dissemination activities and exploitation	27
4.1	Micro-FAST press and Production Management system for Micro-FAST	27
4.2	Nanostructured powders and Multiscale modelling methods	27
4.3	Tools manufacturing process and surface treatments	28
4.4	Ancillary devices for integrated Micro-FAST system	29
4.5	Miniaturized components	31

1 Executive Summary

The main aim of the project has been to develop an innovative powder based production system for volume and FAST manufacture of net shape miniaturised components made of a wide range of materials (metallic alloys, composites, ceramics) in one manufacturing step.

The project led to substantial improvements in the integration of powder manufacturing technology, Field Activated Sintering process, tools and nanostructured materials in one production platform for realizing small scale components thus overcoming the current limitations of existing powder based processes and technologies (MIM, furnace sintering, SPS).

The work has been focused on the design and realisation of the Micro-FAST sintering press and of the sub-systems (powder feeding, die set transportation, ejection, laser die cleaning and inspection) together with the development of nanostructured powder materials and tools to enable an high throughput manufacturing system and process.

The Micro-FAST forming press was assembled with the integrated automated transportation system for the die set. The machine realized in the project is capable to produce small and micro components in the dimensional range from 1mm to 50mm and with several materials as metal alloys, metal composites and ceramic, with elevated process quality and productivity under controlled vacuum atmosphere.

The powder feeding system has been designed to fill small die cavity with high precision tolerance i.e. lower than 1% meaning less than 10mg of deviation for smaller parts. A dedicated ejection system was realized in order to eject the small sintered components after the production process without damaging both the tools and the components.

The inspection system developed in Micro-FAST is able to automatically detect the structural defects of the tools after the manufacturing process and works in combination with the laser die-cleaning system that removes the cluster agglomeration distribution on the tooling surfaces for an accurate cleaning of the tools.

The press and the subsystems interacts through a common software management environment which enables to manage the job recipe requests and the process parameters of each subsystem, monitoring the conditions of all systems in real time during the manufacturing cycle.

The production chain of materials manufacture, quality characterization and testing for the Micro-FAST process has been validated. The process have been demonstrated to work efficiently with a number of nanostructured materials retaining the initial fine structure thus achieving high quality microstructure and mechanical properties for the required applications indicated by the end-users.

The synthesis routes for nanostructured powders processing to achieve the required properties have been up-scaled and the powders produced have been assessed against the quality of a first set of sintered parts. The Micro-FAST process applied to small components and with certain types of materials is able to produce up to 200 parts per hour. The tools for the micro-FAST process have been manufactured and optimized thanks to tool-surface modification techniques and thin coatings and treatment to ensure the required resistance to high temperatures, high load and low friction to be applied during the sintering process.

To support the process development a wide set of sintering tests with a prototype equipment have been performed to tune the sintering process parameters and to optimize the powder materials and the tools. Multi-scale modelling to support the process and the evaluation of technology performance have been developed: this enables the prediction of behaviour of the material during the sintering process and helps to set the process parameters before the production

The technology development have been driven by industrial users which defined the design and selected the industrial demonstrators to be manufactured by Micro-FAST machine. The market analysis and economic impact associated with selection of case studies have been performed.

All the technologies and machine developed have been set up and demonstrated in an industrial environment with the objective to increase the potential impact of the project results. The manufacturing trials of the selected micro-components with Micro-FAST machine were performed with metal alloys for all the demonstrators parts: a watch components, a turbine for electric motor and a piezoelectric actuator. The components were selected with the purpose of demonstrating the

Micro-FAST machine and tools to obtain sintered components with different volume, materials and application sectors.

2 Project Context and Main Objectives

Electric-Field activated sintering technique (FAST) is a latest development in powder sintering which enables an increase of manufacturing flexibility and high-quality components with a wide range of materials - e.g. various metal alloys, Cermets and composites with desired structures and functionalities, including use of nanostructured alloys. However, existing FAST processes cannot be simply scaled down to the manufacture of miniature/micro-components, due to a series of factors like difficulties of handling powders, strong “size-effects” at the micro-scale, different sintering mechanisms at the micro/nano-scale and the lack of tooling design, manufacturing guidance and facilities for mass production of complex shaped components. In fact, almost all the current applications of FAST involve component reflecting these constraints.

A new process and machine concept - Micro-FAST - is proposed to scale down conventional FAST process to the micro-scale (<5.0mm) combining the micro-forming with FAST sintering in a high efficiency system. The process is able to deliver near-net-shaped, bulk fully-dense (up to 100%), micro-parts with expected significant increase of mechanical and functional properties. These parts are used in mechanical applications that require high precision and the use of different kind of materials (i.e. watch industry), in automotive application to enhance the mechanical properties of engine parts made with light alloys, in electro-actuators that need a combination of special materials with difficult geometries, but also in other fields of applications requiring biocompatible or magnetic properties.

The manufacturing system developed in the project relies on a new industrial Micro-FAST automated machine able to work with high-performance nanostructured materials and on new tooling techniques to make dedicated micro-tools that ensure an accurate and reliable geometry of the sintered parts. The machine includes different modules, as the powder-feeding for high precision filling of the mold, inline monitoring and quality inspections systems to ensure the quality control of the parts. In order to support the micro-structural behavior of materials and their interactions with the Micro-FAST process, the creation of an innovative multi-scale modelling technique is also implemented.

The development will lead to substantial improvement in the large scale manufacture of micro components, overcoming the current limitations of other techniques as metal injection molding thanks to the reduction of the manufacturing steps in just one single production system.

The whole development will support the EU-wide product innovation involving use of miniature and micro-components in many manufacturing sectors and, especially with difficult-to-cut and difficult-to-form materials and will take into account energy savings, cost and waste reduction and recycling issues that will be analysed thoroughly through an expertise Life-Cycle Assessment.

Project work flow through the Work packages

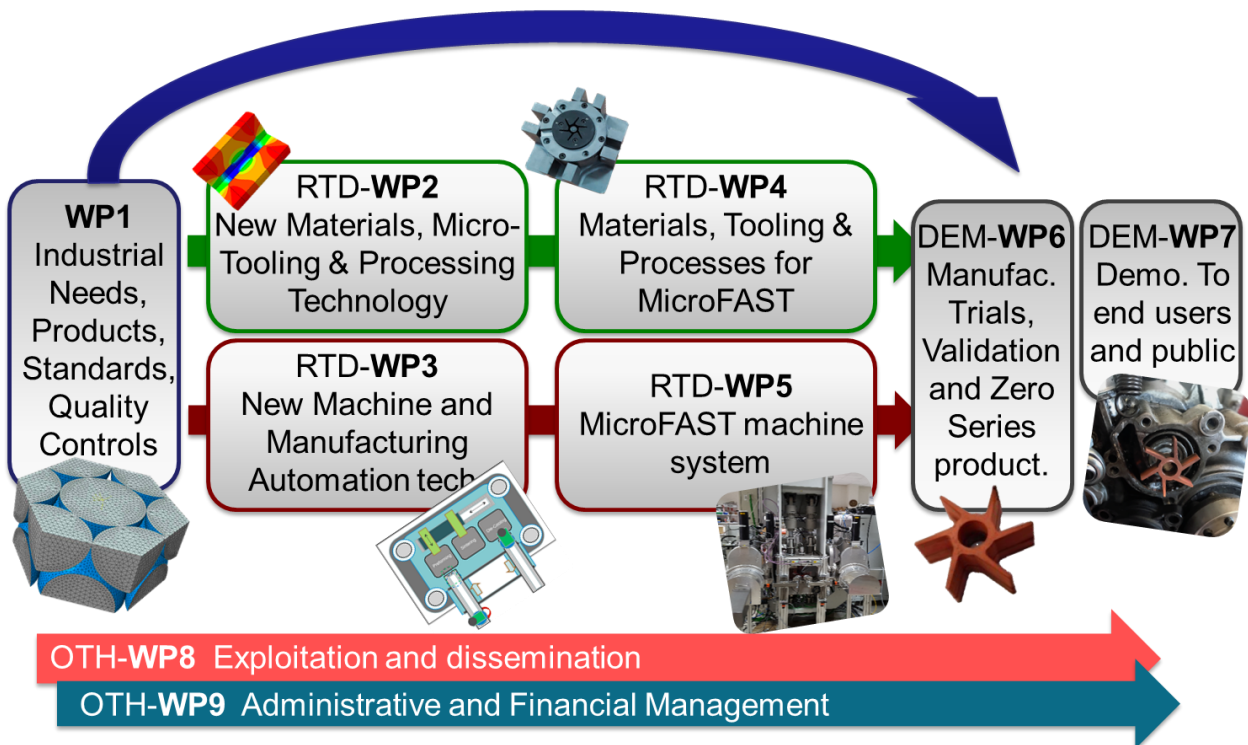

Project objectives

The main projects objectives are as follows:

- Development of a high-precision press which enables Micro-FAST production
- Development of the manufacturing platform, including a die-set transportation system, powder feeder, online die-cleaning and inspection system, component-ejection system.
- Development of sensors, condition monitoring and production management control for Micro-FAST-based manufacturing
- Development of powder materials reliable for Micro-FAST and optimization of the powder production process in order to enable high product quality, reliability and production yield.
- Development of a multi-scale modelling in order to assist and optimize the sintering process and the definition of production parameters.
- Improvement of Micro-FAST-process and equipment optimization for achieving tight tolerances, high accuracy, good surface quality and improved properties of sintered component
- Development and demonstration of innovative tool-technology and tooling-process chains for the manufacture of the targeted products
- Manufacturing by Micro-FAST machine and demonstration of micro-components defined by the end-users and parallel Life Cycle Analysis

3 Science and Technology Results

The scientific and technological achievements of the project are listed and explained as follows: results included the realized prototypes (press and ancillary subsystems), the tools for the sintering processes, the developed powder materials and the components selected as demonstrators for the end-users.

3.1 Micro-FAST press

Description of the result and key achievements

The industrial forming-machine based on the Micro-FAST process principle has been developed for the forming of miniature/micro-sized components with a wide range of powder materials. The press has maximum force of 50KN, enabled by precisely guided hydraulic cylinders. It consists of two working stations – forming/sintering and die/component cooling. These are conducted within a main vacuum chamber (10^{-3} mbar). A die-set containing the powder and forming tools is transported from pre-vacuum chamber to the main vacuum chamber, and then to the third vacuum chamber for further cooling, through an in-situ transport system. Die-set entering the machine and leaving the machine as well as vacuum doors' opening and closures are fully controlled automatically. The heating of the dies/materials is realised by a power transformer, which can heat up the core section of the powder up to 1600°C within seconds. Force, displacement, forming temperature, level of the vacuum and cooling controls can be pre-set and then fully controlled through using various sensors, controllers and advanced software specially developed for this machine. Depending on the geometric features and type of the material to be formed, the machine is able to form parts from s1 to to 50 millimetres in overall sizes. For micro-sized components and certain types of materials, producing 200 parts per hour is achievable.



Fig 1. Micro-FAST prototype machine

Progress beyond the state of the art

Micro-FAST Consortium has developed an industrial version forming machine system – first of this kind of the system in the world enabling automated production of miniature/micro-components directly from loose powders, with a range of powder materials, including metals, ceramics, MMCs, WC, cermets, etc. that are difficult-to-form and difficult-to-cut materials. This is a significant progress from lab type research equipment and existing SPS equipment. In-chamber transport system is an innovate design enabling continuous production with Micro-FAST. Monitoring and control system represents state of the art of such systems for powder-based production; ancillary sub-systems developed during the process as powder feeder, ejector for the sintered components and laser die-cleaning can be integrated in the press in order to obtain a fully-automated volume production chain: this will lead to an considerable advancement in the production of micro-components respect to current industrial solutions, not projected for such volume production.

3.2 In-situ micro-component robotic handling

Description of the result and key achievements

The automated handling within the Micro-FAST manufacturing has to be considered in various areas:

- Die transport between stations
- Workpiece carrier
- Opening/closing Station
- Interfaces between conveyor belt and die transport inside chamber
- Die transport inside vacuum chamber
- Safety precautions for moving parts
- Realization and integration of die transport into chamber

Particular attention was directed to the handling of the die into the vacuum chamber and the handling inside the vacuum chamber itself. Special requirements have to be considered e.g. vacuum capability, minimal available space and electrical insulation to high current circuit for heating. The function of the handling system is:

- Inserting the die into the vacuum chamber
- Transporting the die inside the vacuum chamber to press 1 and to press 2
- Positioning the die between the respective punches
- Extraction of the die out of the vacuum chamber

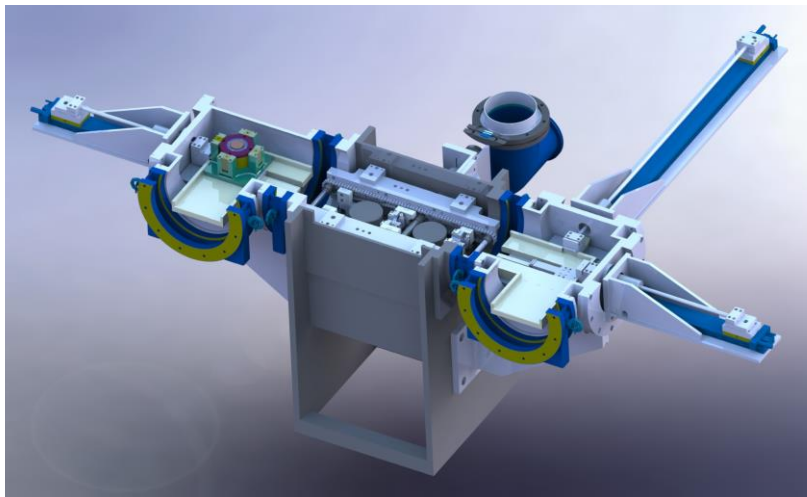

Fig. 2 Sectional view of design of handling system

In above figure the developed handling system is depicted. The movement of the die in the inlet and outlet chambers are realized with pneumatic pushers, which have vacuum feedthroughs. Inside the vacuum chamber is a chain, which is driven by a motor outside the chamber and a rotary feedthrough for the mechanical transfer. The complete handling system inside the chamber is spring loaded to balance the vertical movement of the press. In this way, a very compact and flat system was realized (see picture below).



Fig. 3 Integrated handling system in vacuum chamber

3.3 Condition monitoring, adaptive control and the Production Management System for Micro-FAST

Description of the result and key achievements

FRA-ILT developed a control platform capable to collect the recipe from the press an each subsystems: this control software is capable to collect the process data but each subsystem is autonomous in terms of control and automation.

Next Figures shows the how processes of a module could be stabilized with help of the Micro-FAST Platform Control System and its containing condition monitoring. After each process run the Recipe can be adjusted. This adjustments can either be done manually, based on the experience of a process engineer or with an extension (not implemented) to make adjustments automatically, based on an optimizing algorithm.

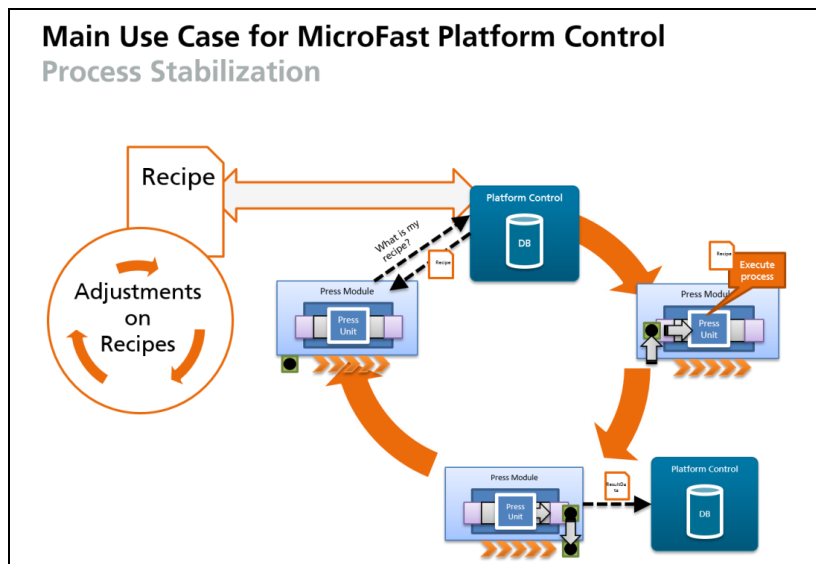

Fig. 4: Use Case Process Stabilization

A graphical user interface (GUI) for mobile devices such as iOS devices was then developed: with this mobile application, each process engineer is enabled to edit key parameters for his process and can check result data

Databases of the recipes are also recorded and updated in the platform, where access is only available for registered users through secure VPN connection: this means that all input/output data can be logged by the system and the data is available for condition monitoring component.

The software and its containing business process for changing setup parameters in real time was demonstrated on an equipment emulation in order to not influence running processes on the Press Module (used for other demonstrations).

3.4 Powders

Description of the result and key achievements

Powders suitable for the selected demonstrator and Micro-FAST process were developed and produced in order to achieve the following objectives:

- Fine powders in the micro-metric size range with regular shape to ensure a flowability suitable for the feeding system
- Nanostructured powder with controlled composition to achieve fully dense sintered components, agglomerated in micrometric particles in order to overcome the problems related to nano-safety
- Production process with high yield, reproducibility, reliability and quality standards

Three different production methods have been developed as follows:

Nanostructured powders by mechanical alloying (MBN)

Different powder grades have been studied and produced by mechanic alloying for micro-FAST process with the main purpose of developing a suitable, reliable and efficient processing procedure that enable to deliver material in the particle size range required by the process, with suitable nanostructure to facilitate the sintering and control of composition and purity of the material.

MBN produced TiSn metal alloy achieving the following targets:

- Homogenous dispersion of Tin in α -Ti lattice
- Avoid the presence of not alloyed low melting Tin phases that might be detrimental in the following sintering process
- Good process yield in a fine granulometric fraction
- Good morphology to provide enough flowability in connection with the fine size of particles requested
- Fine powders with very high surface area that allow to obtain fully dense sintered components at lower temperatures

Steel AISI420 has been selected for the demonstration due to its mechanical properties that fit the requirements for selected demonstrators: AISI 420 was made by HEBM starting from a pre-alloyed FeCr based materials tuned in composition to reach the specified composition of commercial AISI420. High yield of the process within 10÷40 microns particles size range was achieved and the mechanical alloying process was improved in to produce the material with fine microstructure and lower content of interstitial elements.

NiTi shape memory alloy has been developed by mechanical alloying but the targeted phase distribution could not be achieved in the as MA material: this material was not selected for the sintering of final demonstrators and was tested only at lab-scale to verify the applicability of Micro-FAST technology in a wide range of materials. Post treatment methodologies have been developed to achieve the particle size distribution required for the MicroFAST process by Matres and allow the

complete handling of powder production under not oxidizing atmosphere. Flowability tests have been performed adapting new characterization methods properly developed for fine powders with the purpose to verify the suitability of the material for the feeding system developed by MicroLS.

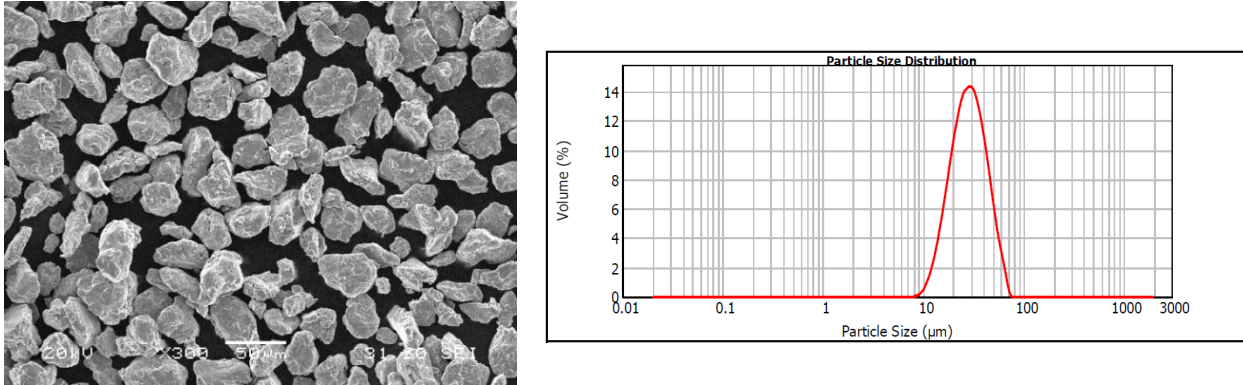

Fig.5 SEM morphology (left) and PSD (right) of Ti-alloy powder produced by HEBM

Progress beyond the state of the art:

The powder produced by MBN achieved a considerable progress beyond the state of the art for Titanium-Tin alloy powder compared to commercially available TiAlV alloy due to the achieved faster consolidation during the sintering process thanks to presence of Tin and presence of smaller grains that facilitate the material diffusion during the heating process.

Besides this, MBN has developed and optimized the production processes by mechanical alloying of specific powder materials for FAST sintering, with high reliability and quality standards, high production yield and control of particle shape and size: this represents a relevant advancement in the production of powder with this method.

Powder materials prepared by improved spray drying techniques (VITO)

The aim of the work performed by the KMP group of VITO was the shaping of spherical granulates starting from nano- or submicron sized ceramic powders. This to achieve powder with suitable flowability to feed to the micro-FAST press and a size distribution to obtain a uniform packing. Various granulation methods were explored to this end such as spray-drying, vibrational droplet generation or aerodynamically assisted jetting.

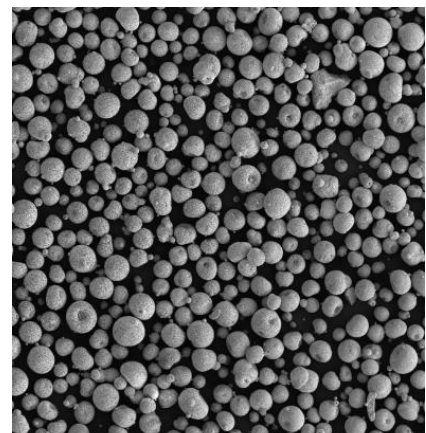

Fig. 6: Electron microscope image of the spraydried MSZ powder used in the micro-FAST trials.

After the initial exploratory phase, spray-drying has been selected to prepare the granulates. In this process, a suspension containing the ceramic powders and organic additives is sprayed into the chamber giving droplets that are dried in heated air. Due to the rapid evaporation of water during the flight spherical granules are formed. The focus has been to limit the amount of organics, while at the same time obtaining a stable and free-flowing powder which can be fed to the micro-FAST machine and that avoids dust formation.

For the final micro-FAST demonstration test close to 1 kg of 4 wt% magnesium stabilized zirconia (MSZ) powder was prepared with a size distribution classified between 25 and 44 µm. Only a low

amount of organic material (~ 1 wt%) was used as an additive, in contrast to more conventional spray drying process (~ 5-6 wt%). The remaining organic material was removed during a calcination step.

Because the spray-drying process gives a broad granule size distribution only 40 – 50 % of the produces material can be used for the Micro-FAST process. The discarded material (both the larger granules as the fines) can easily be introduced in the process again after calcining. This ensures that almost no material is lost. The granules from the re-used material had exactly the same properties regarding size distribution, sphericity, density and material composition as the not re-used material.

Micro-sized powders by hydrochemical synthesis (IMNR)

A versatile hydrochemical process combined with spray drying has been developed to synthesize different types of ceramic nanopowders with controlled chemical, structural and morphological composition. These methods proved particularly promising in terms of controlling the grain size, degree of agglomeration and purity of powders that can be sintered without significantly changing the phase composition by micro-FAST process. The process has been demonstrated for producing ceria-doped zirconia-based powders (Ce-YSZ) for SWATCH watch parts and doped lead zirconate titanate (Nd,La-PZT) piezoceramics.

The process is based on a hydrothermal process in autoclaves at temperatures below 2500 °C and pressures below 100 atm. starting from pure soluble metallic salts in the presence of a hydrolysis agent to control the pH process. The filtered and washed precipitate obtained is re-dispersed in the presence of a small amount of organic binder and granulated by spray-drying at temperatures below 2000C through a calibrated nozzle. No further thermal treatment is required for crystallization, thus allowing one step synthesis of nanocrystalline powders with controlled degree of agglomeration.

The process is designed to minimize the wastes by a simple recycling loop of the by-products, while the agglomeration process eliminates the nano-toxicity risks during handling.

The characteristics of the powders obtained are assessed by certified methods: ICP-OES chemical analysis (main elements, doping elements, purity); XRD (crystallinity); ASTM B 213-03 (flowability);

ASTM B923-02, D7481-09 and B527 (density), particle sizes (sieve analysis). All powders were delivered with safety data sheets.

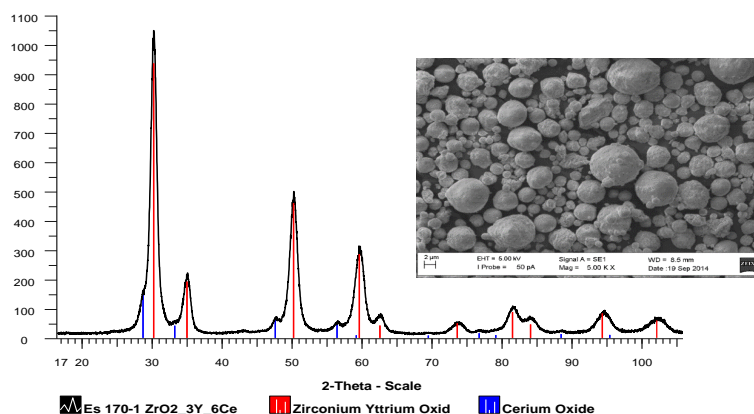

Fig. 7: Ce-YSZ nanopowders main characteristics (left), XRD and SEM of C-YSZ nanopowders (right)

3.5 Multiscale modelling methods

The multi-scale model of sintering was established which is industrially useful for the estimation of force applied and to gain deeper insight into the bonding process, as well as tuning parameters for effective forming and predicting successful combinations.

Two models (micromechanical and diffusion bonding) were developed, dealing respectively with pore diminishing and micro-voids closure that arise from powder stacking and powder surface roughness and also correspond to distinct length scales in size. The yield surface can be used to optimize the loading path for powder compaction in order to achieve a uniform relative density, while the contact parameters serve as inputs for the diffusion bonding model that calculates the time required for full micro-void closure at powder interface and hence is capable of guiding the optimisation of sintering process.

The scientific combination of electro-thermal-mechanical and diffusion models results in an integrated software that can be used for optimisation of Micro-FAST process to efficiently produce high-quality components. The inputs of software are macroscopic parameters, such as operating temperature, compaction speeds, applied pressure, holding time, and the outputs are parameters related to component quality such as porosity as well as the amount and distribution of micro-voids. A micro-scale model can be extracted from the macroscopic model of the Micro-FAST process and then used to improve parameters and thus obtain a quality finish of the entire part.

Description of the result and key achievements

For the micro-scale modelling, a representative volume element (RVE) with periodic boundary conditions (PBC) and material properties of bulk TiSn were implemented using the finite element method. Two RVE configurations were utilised to mimic particle spatial arrangements: hexagonal close-packed (HCP) and face-centred cubic (FCC) crystallographic structures, which allowed an infinite number of particles modelled due to PBC. Initially, a purely mechanical simulation was performed and the results were compared to various analytical solutions in order to validate the model.

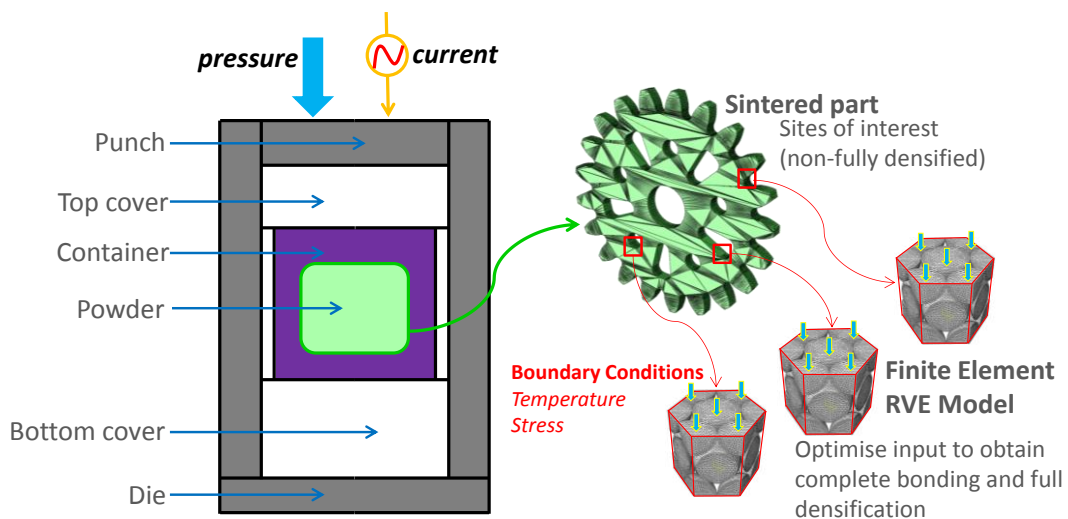

Fig. 8: Schematic of the multi-scale modelling of the sintering process

A coupled thermal-electric-structural finite element model with the RVE, in which a current (direct or pulsed) and pressure are simultaneously applied, allowed the contact stress and temperature (parameters needed to calculate the bonding status) of particles within the assemblage to be predicted.

A macroscopic finite element model was developed in order to simulate the sintering of entire part geometries. The modified Gurson equation described the material behaviour which was then calibrated to the stress-strain curves of the bulk TiSn in order to determine the parameters q_1 and q_2 , where higher q_1 values induced a stronger softening response and q_2 reduces the yield limit as it is increased.

$$p/\sigma_Y = \frac{2}{3q_2} \cosh^{-1} \frac{1 + q_1^2(1 - \rho_r)^2}{2q_1(1 - \rho_r)}$$

The diffusion bonding (DB) model was based on power law creep and interface source diffusion theories, and relates the bonding time (i.e. the time required for annihilation of micro-voids) to macroscopic parameters: temperature, contact pressure at powder interfaces and micro-void size. A numerical model was developed to simulate diffusion bonding during the direct powder forging process. A set of analytical equations was derived and implemented via a user-defined subroutine in the finite element software Abaqus. The DB model was validated using a simple two-hemisphere compression simulation. The numerical results demonstrated that the DB model has the ability to: 1) determine the bonding status between powder particles during the forging process, and 2) predict the optimum value for key powder forging process parameters.

The theoretical DB model has been presented using MATLAB. This model was incorporated with a physical model (two hemispheres being compressed, and then later the RVE) in the finite element software. A diffusion bonding parameter, ω , was defined (which ranges from 0 to 1) to describe the extent of bonding, where 0 represents the initial state and 1 means the surrounding area of this node has been fully bonded.

The combined multi-scale model uses the output parameters of temperature and contact stress in regions of interest of the macroscopic part geometry which then serve as boundary conditions which can be applied to the RVE with the DB model to determine the bonding status at these particle sites.

Progress beyond the state of the art

The RVE and DB models are the foundation for development of multi-scale modelling software. The simulations predict the relative density, temperature distribution, and bonding status of powder particle assemblage allowing the optimum parameters to be inversely determined and thus be effectively used in the design of the Micro-FAST process. The model can be used to easily determine how the mechanical and thermal response varies during the Micro-FAST process for different metals by simply changing the input material properties, hence being time, cost and waste effective. Overall, the multi-scale model quantifies the link between powder, the Micro-FAST process and sintered material properties leading to the optimisation of the final component formed.

3.6 Tools manufacturing process

The micro-FAST tools developed have multi-functions for sintering and forming parts from loose powders at the miniature to micro scales. They are able to provide required high-precision guides to the punches and dies, accommodate use of the automated transport system inside the press, sustain high-temperatures and forming pressures, focus heating onto the sintering/forming areas, as well as accommodate use of an automated powder-feeding system developed in this project and enable easy ejection of the part formed after cooling down of the die-sets. These tool-sets are innovative solutions for Micro-FAST due to which Micro-FAST based production becomes possible. Tool-manufacturing processes involve standard CNC machining, Electro-discharge machining, Laser ablation, Surface plasma nitriding and CVD/PVD, etc.

Description of the result and key achievements

The main results are three sets of micro-FAST forming-tools for the forming of three demonstration parts, namely watch crown (ETA), water pump turbine (DIGR) and actuator shell (CED). The parts of these tool-sets were made from various tool-materials to meet different functionalities of the toolings, including graphite, tool steel, Tungsten Carbide, TZM and ceramics. These tool-sets represent innovation of forming-tool designs for powder sintering and forming which have not been seen before. In addition, there were a large number of simplified dies/punches made from Graphite and TZM for lab experiments. The toolings have been tested with Micro-FAST press and different demonstrator components have been formed. Further effort on tool-design is being made to address challenges of forming high-temperature materials with the Micro-FAST machine.

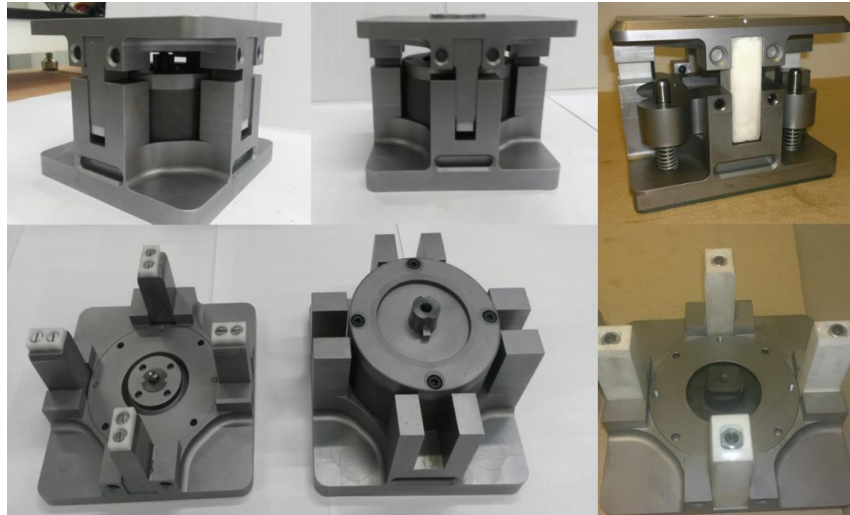

Fig. 9: Micro-FAST Forming Tools

AN innovative process chain for the tool production was demonstrated to fabricate punches suitable for ETA components:

1. Design and fabrication of the new tool set via novel approaches (UOS/PAS).
2. Application of surface modification based on advanced active-screen plasma technology to form a co-alloyed layer and/or a plasma nitrided case with significantly improved surface hardness and tribological properties (BIM).
3. pre-treatment of the new tool with laser technology (ILT).
4. To develop surface coating technology such as PVD ternary and/or quaternary coatings with high wear resistance, oxidation resistance and low friction at high temperatures (AIN).

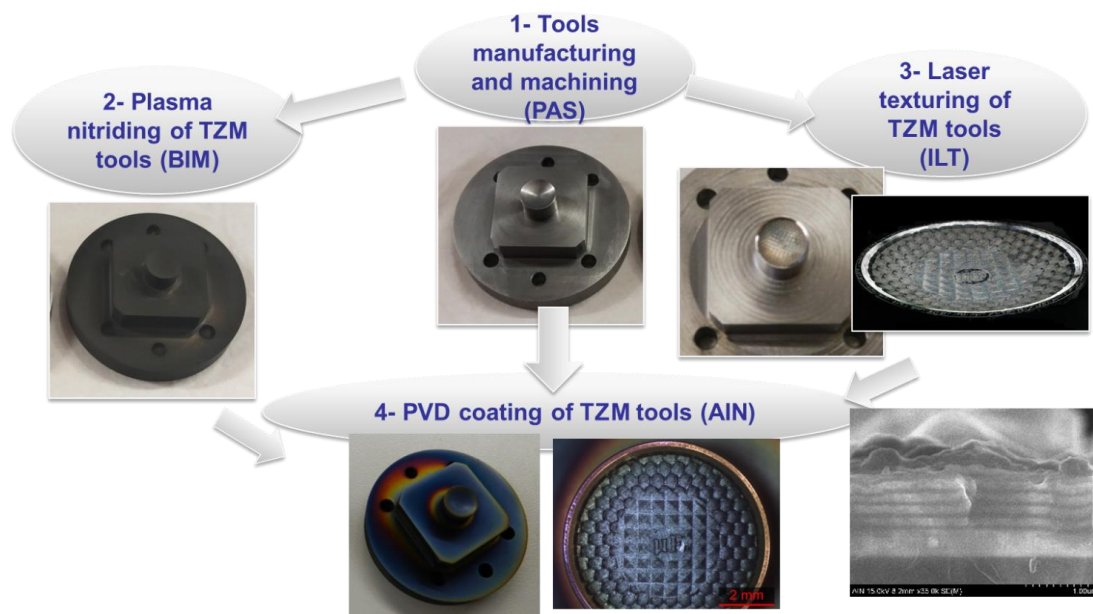

Fig. 10: Tool innovative production chain

Progress beyond the state of the art

The micro-FAST tool is developed along with the Micro-FAST press, which is considered as the first of this kind machine and tool for industrial forming of micro-component directly from powder material without pre- or post-treatment. There are several technical challenges of the tool design, include powder feeding, high temperature resistance, high strength and good electrical conductivity required in the core die part, and electrical insulation with other parts of the tool, as well as a combined part ejector in the tool. It has been approved that the tool is performed well with the designed functional requirement.

3.7 Surface Treatments developed for Micro-FAST tools

Description of the result and key achievements

In Micro-FAST process, when sintering high-strength materials at high temperatures, the major technical problem associated with traditional graphite dies is their premature failure or short lifespan related to the low mechanical strength at elevated temperatures. Therefore tools (dies/punches) must be made from superalloys, refractory metal alloys or even ceramics.

Nickel-based superalloy CM247LC and carbide-strengthened molybdenum based TZM alloys have been identified as alternative tool materials for Micro-FAST process.

Nickel-based superalloy CM247LC has a high-temperature strength, high oxidation resistance and good thermal fatigue resistance, which makes it a good candidate for μ -FAST tools working under high-pressure ($>140\text{MPa}$) and medium-temperature ($<1000^\circ\text{C}$). However, the material's tribological properties are characterised by high friction and higher wear which can be enhanced by a novel plasma co-alloying simultaneously with both interstitial element N (i.e. nitriding) and substitutional alloying elements (such as V and Ag) by BIM. The room temperature tribological performance of CM247LC has been improved after plasma co-alloying with vanadium and nitrogen (i.e. V/N). Tribotests at elevated temperatures carried out in AIN have proved that plasma co-alloying with silver/vanadium/N (i.e. Ag/V doped + nitride layer) is helpful to lower the friction coefficient of CM247LC at temperatures up to 600°C . This nickel based materials can be used as Micro-FAST tools for sintering materials at a temperature up to 1000°C .

High strength at elevated temperatures, high thermal shock resistance together with a low coefficient of thermal expansion and high electrical conductivity make carbide-strengthened molybdenum based TZM alloys a material of choice for micro-FAST tools working under high-pressure and high-temperature (up to 1500°C). Their poor oxidation resistance at ambient environment needs to be addressed by controlled atmosphere and surface treatment, and their poor tribological performance needs to be improved by surface modification process. Plasma nitriding was carried out in BIM using a 60kW Klöchner DC plasma furnace at a pressure of 4 mbar. The treatments were carried out at the temperature between 660-700°C for varied times in a mixture of 25% nitrogen and 75% hydrogen to optimise the effect. The experimental results have demonstrated that TZM alloy can be successfully plasma nitrided at 660°C and above to produce a thin hard molybdenum nitride case supported by a diffusion zone. Plasma nitride TZM punches has been tested in the field sintering test up to 1000°C. TZM punches have been duplex treated with plasma nitriding and PVD mono composite and multilayer coatings, the nitride layer and the diffusion zone provides a strong support for PVD coating to improve the oxidation resistance and tribological properties of TZM alloys at elevated temperatures.

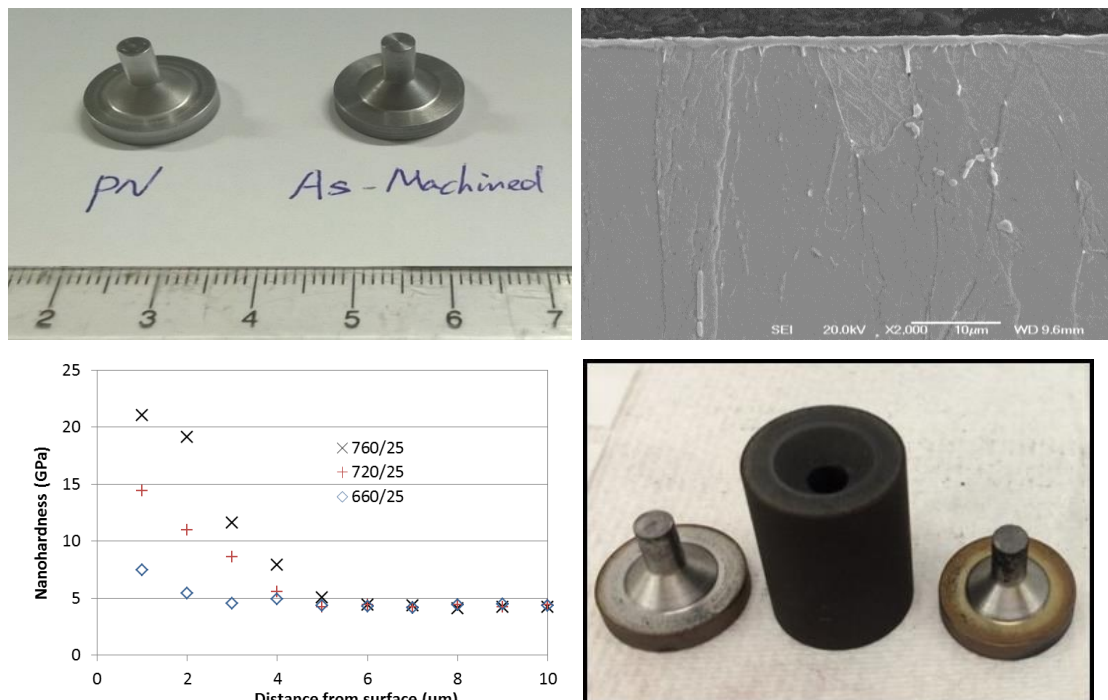

Fig. 11 (a) Comparison of as-machined and plasma nitriding treated TZM punches, (b) A cross-sectional view of plasma nitriding treated TZM sample (c) hardness profile under the nitride layer (d) Plasma nitrided punches after field test.

Progress beyond the state of the art

Plasma nitriding treatment on TZM punches and tools entitles the tool with a hard layer supported by a hard diffusion zone with a significant thickness therefore the load bearing capacity and wear resistance of the tool is greatly enhanced. Together with the PVD coating, it will improve the oxidation resistance and wear resistance, therefore makes TZM tools to replace the existing graphite tools possible and increases the tool life greatly.

The novel plasma co-alloying simultaneously with both interstitial element N (i.e. nitriding) and substitutional alloying elements (such as V and Ag) developed by BIM can be used to treat different hot working tool materials include Nickel based material and molybdenum base refractory materials.

3.8 Surface coatings for Micro-FAST tools

To enhance the surface properties of some micro-tools with demanding service conditions (high pressure, high temperature), advanced surface coating technologies, such as PVD, have been introduced to generate novel micro-tools with superior surface properties for Micro-FAST.

Description of the result and key achievements

Besides considering the requirements of mounting the tools to the machine where mechanical connection, electrical insulation and thermal isolation... tool-material selection has been a major concern in order to substitute graphite in two main situations: where it can cause contamination on components and for sintering ceramic powders at the required high-pressure and medium-high temperatures. When substituting graphite by other materials such as Ni-based super alloys or Mo-based refractory alloys due to their superior strength at high temperature protecting their surface from oxidation becomes a mayor challenge and PVD coatings have been developed and used with that purpose. Also tuning the superficial properties of the tools such as friction coefficient and wear resistance is an important goal. Both have an important impact on the quality of Micro-FAST manufactured components and the tool life.

It is known that TiAlSiN coatings can withstand up to 900°C without significant oxidation by forming barrier layers based on alumina. Nevertheless, when sintering some materials, p.e. alumina powders, higher temperatures need to be reached (up to 1300 °C). It was expected that the oxidation resistance of the protecting PVD coatings could be further improved by developing Cr-based multi-component nitrides or oxides.

During this project AlN has developed coating formulations by PVD specifically designed for hot forming (micro) tools & dies. The developed coatings have been quaternary nitride and ternary oxide Cr-based coatings with different structures: monolithic, gradient and multilayer. The development carried out in the project has included an exhaustive study of a series of process parameters (pressure, gas mixture, bias,...) affecting the properties of the deposited coating.

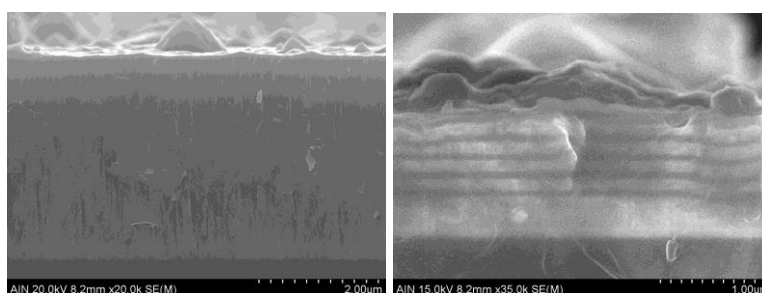

Fig. 12: Cross-section view of a CrAlSiN monolayer (left) and a CrAlOxN/CrAlN multilayer (right) coatings.

Selected coatings, in occasion in combination with surface treatments from BIM and laser texturing from ILT, have been tested on TZM punch demonstrators in order to validate the behaviour of the coatings in real working conditions.

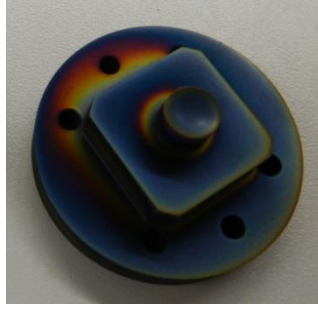

Fig. 13: TzM punch with plasma nitriding + PVD coating.

After a series of field trials on different combination of punch and die made of TzM and graphite material, it can be concluded that a novel tool-fabrication process chain using laser, surface modification and PVD coating has been developed to satisfy the requirement of Micro-FAST process. Here some of the conclusions obtained after the tests:

- Molybdenum based TzM can be used as tool materials, when properly protected, from 400 to 1300°C.
- The dimension and the clearance of the TzM punches/die need to be carefully designed to avoid demoulding issue. The surface of the TzM punch/die needs to be polished to avoid deterrence in the demoulding process.
- Plasma nitriding enhances the TzM alloy with a greater hardness which provides a strong support for the PVD coating.
- Duplex treatment, plasma nitriding + PVD coatings, can enhance the performance of TzM tool:
 - PVD CrAlSiN coated TzM punch performs well at temperatures of 900 and 1100 °C.
 - PVD multilayer CrAlN/CrAlOx coated TzM punch performs well at temperatures of 1200 and 1300 °C.
- A proper surface cleaning after each sintering might be needed to maintain the quality of tools and micro-parts.

3.9 Laser die-cleaning

Description of the result and key achievements

Fraunhofer ILT partner has developed a laser-cleaning technique as a stand-alone prototype but capable to be integrated in the Micro-FAST press. The powder of the work piece can partially fuse with the material of the punch due to the high pressure and high temperatures during the sintering process: high viscosity of the liquid metal can lead to a significant build-up of residual layer on the punch and die in small cavities and, consequently, the inspection and cleaning of the punch is necessary to assure a high quality of the produced part.

The cleaning stations will consist of following modules:

- Optical inspection and automated detection of contaminations
- Removal of dust and powder with compressed air
- Flexible steering optics for the laser processing of 3D parts
- Variable focus shifter for different beam diameters and thus different cleaning parameter

The design the prototype are described in the following table.

Station design

- Stand-alone system with PC control
- Motorized axis for tool change
- Galvanometer scanner + focal shifter
- ns laser source
- Enclosure with pneumatic gates
- Dual SPS for safety and control
- Optical inspection unit
- Flexible air nozzles for cleaning

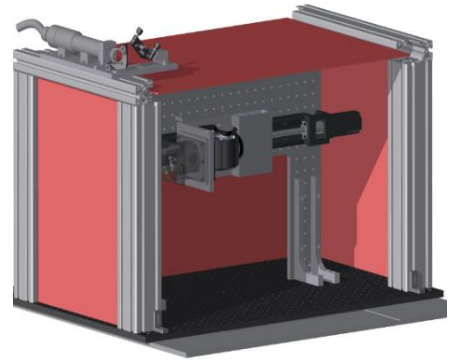

The developed vision system is based on machine learning for adaptive identification of contaminations: it used a 16xLED ring for illumination from different angles and includes an automated learning of properties of contaminations

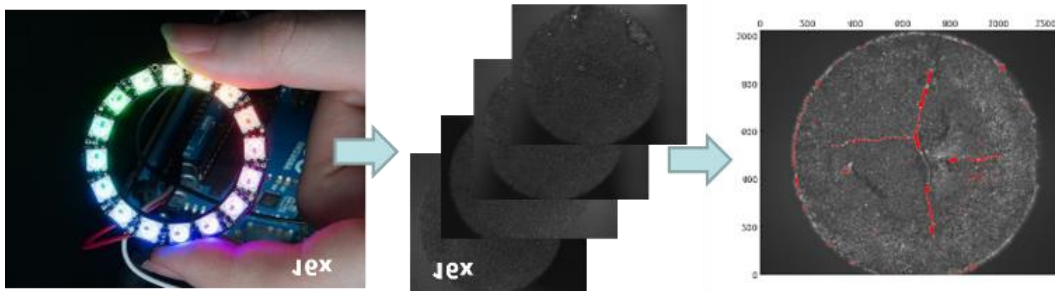

Fig. 14: Contamination detection of the cleaning system

The Control software and user interface is easy for all process steps and allows the adjustment of laser parameter, the adjustment of air cleaning time and bursts. It includes a satabase for storing information for individual die-sets.

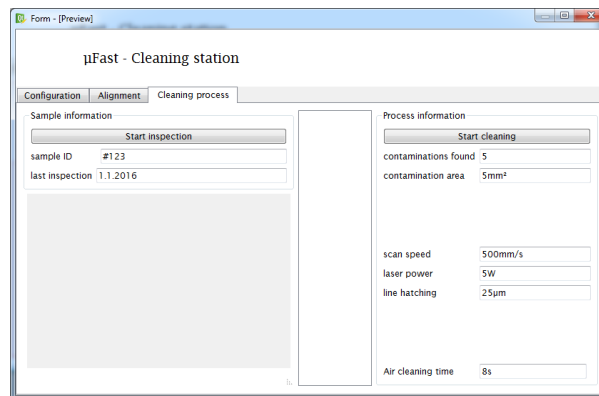

Fig. 15: Software control interface

Progress beyond the state of the art

ILT has developed an innovative automated process for selective removing of contaminations: the function-based tool surface texturing allows to selectively clean the tools with a consequent increasing of the tool life and of the reliability of the sintering process.

3.10 Powder feeding system for micro-manufacturing applications

A feeding system for Micro-FAST with accurate and reproducible filling of small volumes was developed and assembled; the prototype system was validated and demonstrated for the filling process of different metallic and ceramic powders produced during the project: filling process is fully automated suitable for the industrial production and for the integration in the Micro-FAST production chain.

Description of the result and key achievements

Working principle of the prototype is resumed in next Figure: it is based on a cylindrical vessel, calibrated to the exact same volume as that of the powder to be delivered. The vessel is filled under reproducible conditions of vibration level and time, then it is moved over the die and the powder is released opening a sliding gate valve. This concept was selected because was the most suitable for filling the volumes required to produce the selected demonstrators with for Micro-FAST machine.

For each new model of part to be sintered and for each powder to be used, a specific feeding vessel (defined as “holder”) need to be calibrated to a calculated volume.

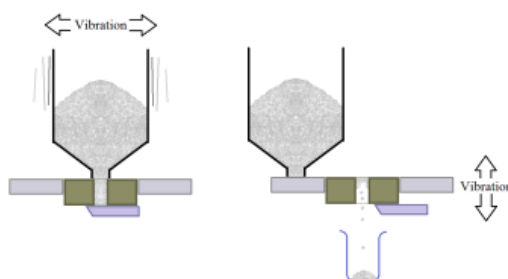

Fig. 16: Working principle of powder feeding

The process parameters are set via a 5” touch screen display running a dedicated user-machine interface; recipes containing all the process parameters for a specific process can be stored on local memory. Moreover, a Diagnostic page is available to control each component of the system and a Settings page for movements points calibration and remote communication protocols.

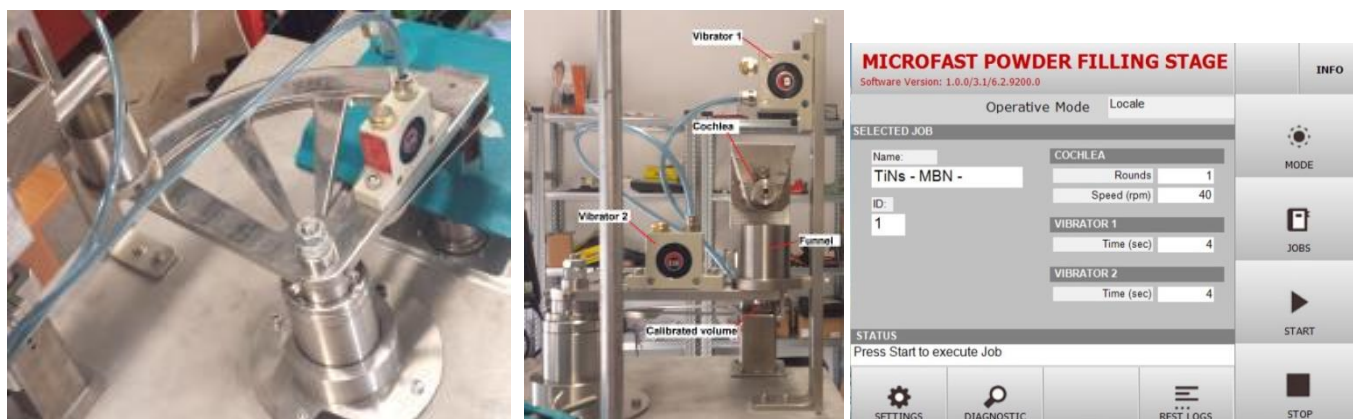

Fig. 17: Feeding system (left, middle) and software control (right).

All powders developed for the demonstration (TiSn, stainless steel, zirconia and PZT) showed good reproducibility in the filling process with relative standard deviations of the weighed powder below

the target of 1%. The standard deviation measured has been used to calculate the possible accuracy obtainable for the fabrication of the demonstrator designed by end-user SWA-ETA which has the smallest and most critical dimension among the selected demonstrators. Thanks to the good reproducibility of the powder delivered by the feeder at each cycle, the expected dimensional errors in the sintered part are included in an acceptable range.

After the finalization of reproducibility tests and the verification, the feeding system was then successfully demonstrated.

Progress beyond the state of the art

The developed feeding system is set for the filling of small volumes with high precision, and it is suitable for wide range of powder materials and irregular powder shape.

3.11 Inline forming-tool inspection

A hybrid system consisting of laser scanner and endoscope visual system with dedicatedly designed plug-in based software has been developed to accomplish the inspection task in Micro-Fast. The problem is formulated as inspection of convex and concaved features and the system is designed based on this modelling to deliver an effective solution. A 3-axes gantry moves the hybrid head around to retrieve data and the plug-in structure behind the software provides a powerful tool for data processing.

Description of the result and key achievements

Testing the device with software developed has been conducted repeatedly against simulation and real-world die-punch sets. Graphic presentation, numerical computation as well as key use-case tests have been conducted which showed the system to be stable and peripheral functions are tested as well. For the tool used for forming the DIRG demonstrator, positioning (including the direction) computation and live-filtering in customized zone have been demonstrated. At the end, wing-end areas are examined in a global way – computation of area. For the simplified ETA tool, a plug-in has been accomplished, showing the computation on the curved surfaces and a point-to-point comparison of the surfaces. For the Cedrat tool, a simple plug-in has been tested, featuring noise filter out with different power outputs and stability of the orientation detection (elliptic fitting method). All outputs can be presented in Excel format.

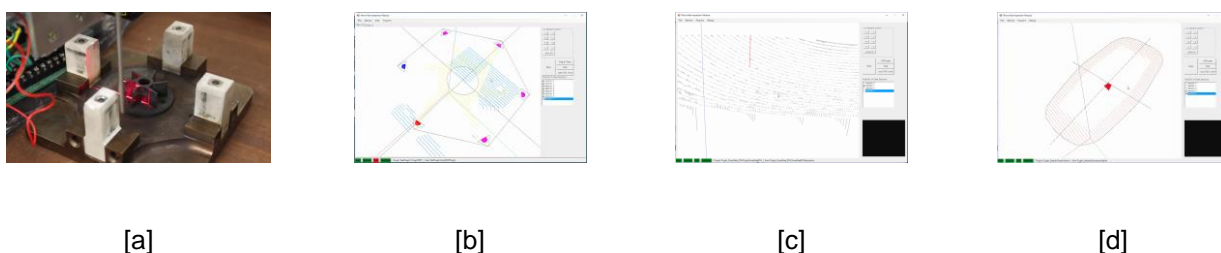

Fig. 18: [a]: Hardware in a scanning process; [b]: DIRG tool result visualization; [c]: point to point comparison after computation of curved top surface in the simplified ETA tool; and [d]: after filtering out of noise, orientation detection by elliptic fitting shown.

Progress beyond the state of the art

First hybrid die-inspection system for micro-manufacturing which enables inspection of miniature/micro-replication forming tools with a full automated model. It can be used in any miniature/micro-manufacturing processes where replication tools are used (key enabling device for automated production of miniature/micro-components, internationally leading).

3.12 Ejection system

Originally the ejection was intended to occur inside the sintering press, as common practice for most processes to ensure precision and lower equipment investment: the consortium decided to develop the ejection system as a stand-alone prototype, also due to decision of using vacuum during sintering process and consequent need of smaller vacuum chamber (to faster achieve the required vacuum), not compatible with the initial design of an integrated ejection system. As consequence, a simplified ejection press has been designed and realized with the active collaboration of UOS and PAS: it is controlled manually, the die-set must be placed and removed manually, as must the component be removed manually from the tray after ejection.

Description of the Result and Key achievements

The initial concept for the ejection system was intended to be an integrated station on the fully automated Micro-FAST machine: the ejection station was originally designed for the pallet conveyor belt, which the Micro-FAST machine relies on, but as a consequence of moving outside the Micro-FAST machine, the concept was simplified for demonstration, using a manual hydraulic press.

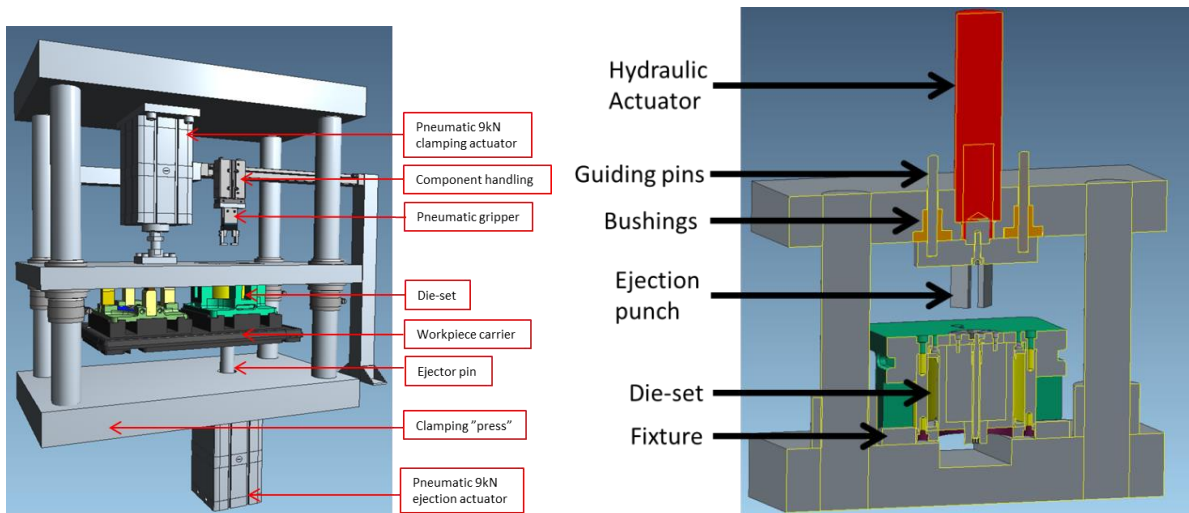

Fig. 19: CAD design for first automated system (left) and final manual concept (right)

The new press was designed to eject the demonstrators with an ejection force of at least 23 kN and to be compatible with the die-sets and the tools for the demonstrators developed in the Micro-FAST project: the die set frame and dies have to be placed in the ejection station after the sintering process and then the sintering component can be removed; furthermore the whole setup was built into a standard two columns-frame for a rigid and flexible construction.

Tests of ejections for the sintered components were performed with samples made of commercial copper and the prototype was demonstrated.

3.13 Manufactured demonstrators and LCA

Description of the manufactured demonstrators and key achievements

Watch components

ETA is interested for the manufacturing of watch external parts in light and hard materials. Usually with conventional technics, the manufacturing of this kind of parts pass through the debinding and sintering steps. The Micro-Fast project with its objectives mass production and full automatic process without debinding step is compatible with our vision for the production of this kind of parts in the future. Furthermore with Micro-Fast process we can challenging the manufacturing of watch external parts in Stainless Steel, TiSn as well as Zirconia. Therefore the Micro-Fast machine has to be under controlled atmosphere for this multi-materials purpose.

The selected demonstrators at the beginning of this project have been replaced by only one much more closer to the possibilities of all other technics in Micro-Fast process. For this reason the watch crown has following advantages:

- Volume and volume control of the powders
- Simplify the tooling design and its manufacturing
- Simple qualification of the demonstrator

The Micro-Fast project has demonstrated the possibility of a complete and full automatization of the core of the process. We have used and tested the mobile concept tools. But unfortunately we could not continue to perform the tool design in order to manufacture watch crown in Stainless Steel, TiSn and Zirconia with a satisfied consolidation/densification.

Automotive Turbine

Diad Group is developing an EV range extender consisting of a micro unit characterized by high power density, two strokes, 125cc engine, not be used to drive the EVs, but only to recharge their batteries. The idea is based on a redesign and downsizing a traction engine to a range extender, that will lead a complete redesign of materials and shapes to increase the maintenance interval and making it close to 30.000 km. One of the most stressed parts is the cooling circuit, adopting a mix of water and additives (ethylene glycol, propylene glycol, organic and inorganic inhibitors, etc.) and working in a temperature range from -30°C up to +135°C with high electromagnetic disturbances. In the configuration selected the cooling water pump is a centrifugal pump driven directly by the crankshaft of the engine, without any transmission belt: the pump circulates fluid whenever the engine is running and the rotation speed is proportional to the engine speed. The cooling turbine is a critical component and represent a bottle neck for the range extender reliability: the actual polymers/aluminium turbines are showing poor performance in the liquid and the mechanical performances are not at all good enough for the targeted maintenance interval. The adoption of a titanium alloy for the cooling turbine will allow the advantage of reliability and maintenance intervals, keeping low the component weight: the specific strength of titanium, around 288 kN·m/kg, is higher than aluminum 7075-T6, around 204 kN·m/kg. Moreover the Titanium alloys represents an excellent combination of strength, corrosion resistance, having the additional advantage to be heat treatable. DIGR and MBN have decided to adopt TiN powders for the MicroFAST sintering of the cooling turbine. MBN has done a strong effort for the optimisation of the powders uniformity (size, shape, composition, ect.). UOS has carried out preliminary production trials in their laboratory adopting Pascoe WC dies and copper powders. The critical features of the cooling turbine have been analysed and the component design has been slightly adapted to MicroFAST technology (product to process adaptation).

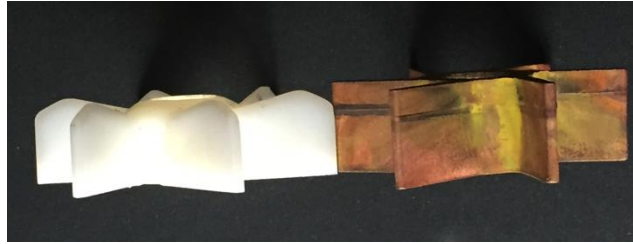

Fig. 21: Product to process adaptation: conventional geometry vs simplified design

Initial trials of TiSn cooling turbine sintering of have been done at the AFT shop floor using the MicroFAST prototype machine and Pascoe carbon dies. The preliminary results were promising, but the carbon dies tool life was too short for completing the sintering parameters optimisation.



Fig. 22: TiSn cooling turbine sample

As a consequence the quality achieved for the TiSn cooling turbine sintering was not sufficient for the validation in real conditions, therefore the demonstration of the case study has been done using a copper cooling turbine sintered adopting the MicroFAST technology. This component shows acceptable geometrical and surface quality, but the mechanical properties aren't comparable to target values, because of use copper powders in substitution of TiSn.

Nevertheless the cooling turbine has been tested using the test bench prepared by Diad Group in the second part of the project and simulating: (I) EV range extender application (PHEV, hybrid aircrafts), (II) motorsport application (possible additional exploitations of the developed part on motocross, enduro, supermotard kart, ski-doo).

At this purpose it is important to remember that in this 2 strokes engine configuration the cooling turbine is directly connected with the transmission, therefore the its rotation regime is almost constant in the EV range extender, but it is dramatically variable in the motorsport applications.



Fig. 23: Test bench validation of MicroFAST cooling turbine

On the basis of the test bench results, the cooling turbine, produced using the MicroFAST technology and adopting the simplified geometry, showed a general functionality comparable to the conventional cooling turbines. In fact different cycles "EV range extender mode" and "motorsport

mode” have been tried at the engine bench and the evolution of the coolant temperature was similar adopting MicroFAST or a commercial turbine. The endurance validation of the MicroFAST cooling turbine must be done necessarily on the final titanium part, therefore it will be carried out as soon the process parameters and the carbon dies will be optimized and the final part realized using the AFT machine.

Piezo-actuator

Final aim of the demonstrator is to demonstrate the possibility to be manufactured in one hand, and the capacity of the sample to withstand the working conditions of the actuator in the other hand. Typical factory verifications are based onto two main tests: admittance measurement through frequency and free displacement measurement.

Admittance measurement allows getting information about the frequency behavior of the actuator. Indeed, piezoelectric actuators are converter between electrical to mechanical energies. The piezo ceramic is equivalent to a capacitance from electrical point of view. Additionally, when actuator is excited closed from its resonance frequency, behavior is showing increase in admittance and change in phase. Therefore, measuring admittance during a sweep in frequency is a way to determine frequency behaviour of a piezo actuator (or mechanism). Admittance is measured using Cypher C60 analyzer. It produces input signal and measurement. Resonance frequency is measured widely higher on Micro-FAST than in standard (77000Hz versus 25000Hz). Additionally, the amplitude of the admittance peak, as well as the change in phase is also smaller. Hypothesis is that actuator is widely stiffer than standard one.

Free displacement is one of the main characteristics of piezo actuator. Indeed, user are typically looking for displacement performance when they are considering piezo actuators. In order to measure this performance, it is not possible to make validation using standard factory verification test bench because of lack in mechanical interface in the sample. Interferometer is therefore used to measure stroke. 6.6 μ m full stroke is observed on Micro-FAST sample, which is far from 42 μ m measured on standard one. Considering that the single piezo stack is able to perform 5 μ m by it-self, amplification coming from shell is very limited. This is coherent with the stiffer actuator measured earlier.

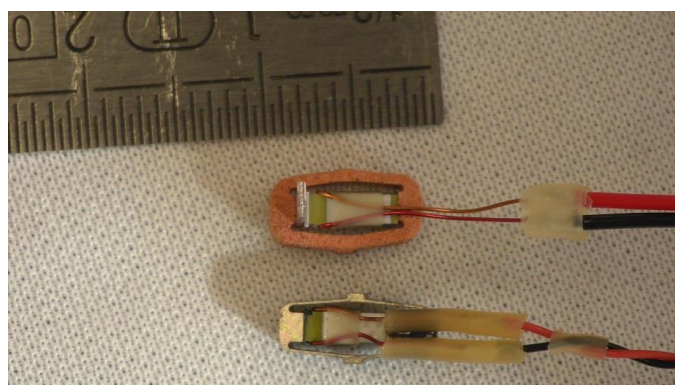

Fig. 24: Comparison between Micro-FAST actuator (top) and standard actuator (bottom)

Description of the LCA analysis performed

The LCA methodology has been introduced to the MicroFAST partners since the beginning of Project, adopting a customised approach and creating a LCA Team composed by a responsible for each industrial case study, for each MicroFAST powder, and for each subsystem of the MicroFAST production system. Then have been agreed the goal, scope, approach, functional units, boundaries, assumptions of the LCA. The environmental assessment has been structured in three steps of work:

1. LCA of industrial case studies adopting conventional technologies;
2. LCA of industrial case studies adopting Micro-FAST;
3. Comparison: assessment of increase/decrease of the environmental impact of Micro-FAST respect to conventional production.

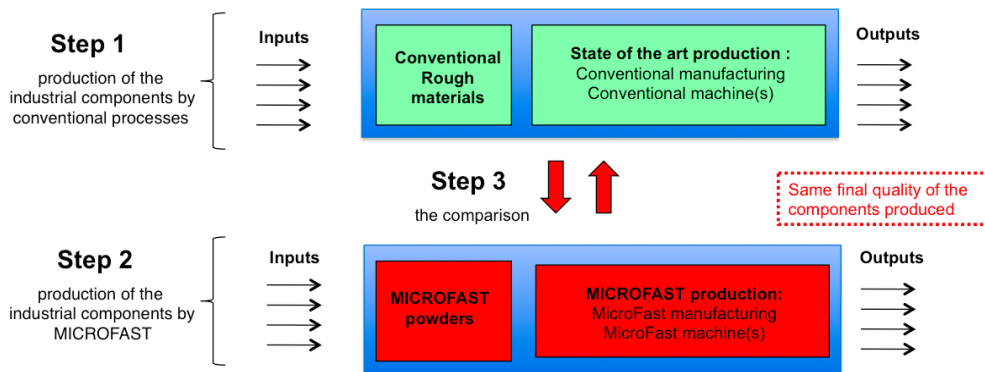

Fig. 25: Different phases of the environmental assessment

In order to complete the LCA, relevant assumptions have been done in the assessment of MicroFAST machine, therefore the achieved conclusions must be considered as a living document that will progress together with the optimisation and validation of MicroFAST technology.

- MicroFAST shows environmental advantages respect to industrial sintering processes (ETA production): this is evident considering the impact assessment normalization.
- These advantages are mainly due to the use of the new powders, “ready to press”, not requiring any addition of binders or solvents and significantly reducing the sintering process emissions.
- On the other hand the MicroFAST prototype (Gleeble machine assumption) seems to require more energy than conventional sintering, therefore it will be necessary to increase the energy efficiency of MicroFAST machine.
- The thermal optimization of MicroFAST tooling and the design of more efficient production cycles will provide further energy saves.
- The environmental advantage of MicroFAST technology respect to the machining from solid of difficult to cut materials (titanium alloy) is clearly demonstrated in the DIGR case study.
- Similarly CEDRAT case study shows the environmental advantage of MicroFAST respect to wire EDM of stainless steel.

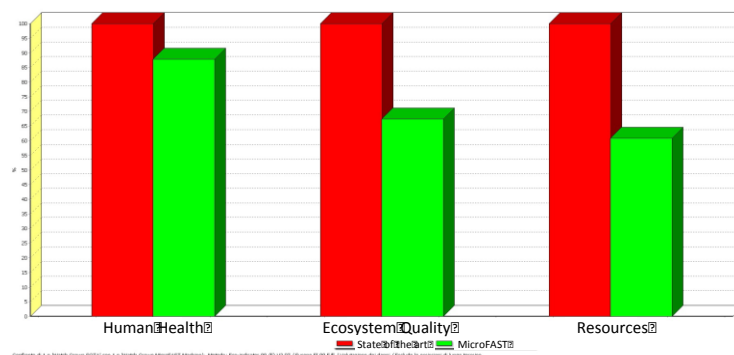

Fig. 26: Zirconia watch crown production: State of the Art (in red color) vs MicroFAST (in green color)

4 Potential impact, main dissemination activities and exploitation

4.1 Micro-FAST press and Production Management system for Micro-FAST

Partner AFT:

With an increased demand on the miniaturization of products and devices, there is a great market potential for micro-parts and micro-structured components for various applications such as MEMS (Micro-Electric-Mechanical Systems), micromechanical devices and biotechnology products. One of the key challenges is still, however, manufacture of multi-materials products, especially the products/parts used in extreme conditions.

The Micro-FAST is a technology developed to address such challenges. Its theory and process had been validated in the lab. However, a production machine was not available. The Micro-FAST machine developed in this project is the first of this kind of machine which is able to simultaneously, directly form functional miniature to micro-sized components from loose powders without using binders. The machine design is expected to generate significant impact in micro-manufacturing industry, and manufacturing machinery industry in general.

Current and potential users include manufacturers of miniature/micro-products/parts, who intend to shorten production cycles, reduce running cost, and produce products with multi-materials. The machine can also be used for general purpose thermo-mechanical tests of materials, Electrical plasticity forming of bulk components from metals, projection welding of thin-sheet-metal parts, etc.

Partner FRA-IPA:

The possible impact, exploitation and dissemination of the integrated handling system developed fra FRA-IPA are related to the press; anyway the accurate transport system that now is integrated only in the vacuum and sintering chambers can be integrated to a wider automated chain that includes the other ancillary sub-systems as the feeder, the inspection and the laser die-cleaning prototype.

Concerning the Management System developed by FRA-IPA, the principal of the Recipe Management can be deployed on other machines as well. The developed solution represents a solid baseline implementation to adapt other processes as well. This concept might be very valuable for SMEs to build very flexible and modular production machines. With this event-driven and cloud-bases approach new business models like pay-per-use can be established. Additional features or improvements can be deployed to the machine without changing hardware parts or needing physical access to the machine.

4.2 Nanostructured powders and Multiscale modelling methods

Partner MBN:

MBN is capable to produce and process by HEBM the powders developed in the project at industrial scale with high reliability, yield and quality standards; the developed production techniques allow to modulate and control composition, size, shape and micro/nanostructure of the powders, achieving materials with suitable properties for the a wide range of applications: the produced powders can be provided to interested customers both for the sintering of micro-components and also for a wide range of applications in the additive manufacturing sector, because the production methods allow to achieve powder with the controlled fine size, shape and composition required for this application.

After the project MBN is ready to apply the process parameters for the manufacturing of other powder materials and produce at industrial level powder batches for customers.

Partner VIT:

High-quality free-flowing powders can be of importance for various manufacturing technologies involving automatic shaping and sintering process applications.

- Spherical granulates with consequent high sphericity are important for automatization of the feeding. Potential markets are micro-components and 3D printing
- By decreasing the amount of organic binder required to stabilize the granulates or by using alternative binders the these granulates can be used for processes were organic additives cause problems (e.g. during sintering).

After the project the obtained results will be used in further developments (e.g. our research in additive manufacturing. Plan for exploitation after the project. Furthermore this research can bring new contract research into manufacturing flowable granulates for companies.

Partner IMNR:

The high quality and reproducibility of doped zirconia and piezo-ceramic doped PZT open further developments in obtaining high precision sintered ceramic parts with near net shape and controlled properties using field assisted sintering processes.

The versatility of the combined hydrothermal and spray drying process may be further exploited in developing a larger class of precisely doped ceramic agglomerated nanopowders with pre-designed properties. Some original results were disseminated in the paper titled: "Hydrothermal synthesis of nanostructured materials for energy harvesting applications" published in *International Journal of Materials Chemistry and Physics 2015, vol. 1, pages 31-42, authors Radu R. Piticescu, Adrian M. Motoc, Albert I. Tudor, Cristina F. Rusti, Roxana M. Piticescu, M.D. Romero-Sanchez*.

A training course for specialists working in advanced materials applications domain was issued.

The know-how developed during MicroFAST project will be valorized by IMNR within the spin-off company HYNAMAT srl, with financial support from Romanian Structural Funds Competitiveness Programme. Future actions for exploitation of the results on hydrochemical synthesis of nanopowders regards participation in new H2020 and National Projects and a doctoral thesis related to "*Thermodynamic predictions in controlling interphase physical-chemical processes in doped nanostructured powders*".

Partner ICL – Modelling:

The impact of the micro-mechanical RVE and analytical DB models allow the relative density, temperature distribution, contact stresses, and bonding status respectively to be predicted within a powder particle assemblage. This allows the optimum input parameters of pressure, current and holding time to be inversely determined and thus be effectively used in the design of the Micro-FAST sintering process.

The exploitation of this work beyond this project will involve executing continuum macro-scopic sintering models of entire part geometries and powders to extract boundary conditions for sub-models of specific regions of interest within the part using the fully coupled RVE and DB models.

4.3 Tools manufacturing process and surface treatments

Partner PAS:

With an increased demand on the miniaturization of products and devices, there is a great market potential for micro-parts and micro-structured components for various applications such as MEMS (Micro-Electric-Mechanical Systems), micromechanical devices and biotechnology products. One of the key challenges is still, however, manufacture of multi-materials products, especially the

products/parts used in extreme conditions. The tools developed are, therefore, expected to generate significant impact in micro-manufacturing industry, and micro-tooling in general.

Current and potential users include manufacturers of miniature products who intend to produce multi-materials miniature and micro-components, especially with difficult-to-deform and/or difficult-to-cut materials, such as metal alloys, ceramics, cermets and MMCs. PAS has developed their experience and know-how on the tool design and manufacturing for micro-forming/ powder sintering industrial.

Partner BIM:

Plasma nitriding treatment uses a plasma discharge of hydrogen and nitrogen gases both to heat the material surfaces and to supply nitrogen ions for nitriding. Plasma Nitriding is an established and successful process particularly important for hot work tools and precision machined parts. The process induces compressive stress, which will improve fatigue strength with negligible dimensional change which requiring very minor (or zero) lapping, polishing or grinding after treatment. It generally leads to no reduction in the core hardness of the substrate of the component. It is a clean thermo-chemical process for the component – e.g. no heavy contaminant or residue. The process is also environmentally friendly as only nitrogen and hydrogen gases are used.

Plasma nitriding treatment on TZM punches and tools entitles the tool with a hard layer supported by a hard diffusion zone with a significant thickness therefore the load bearing capacity and wear resistance of the tool is greatly enhanced. This treatments will be suitable for various materials like hot working steels containing one or more of the following elements, including molybdenum, chromium, aluminium, titanium, vanadium.

The novel plasma co-alloying simultaneously with both interstitial element N (i.e. nitriding) and substitutional alloying elements (such as V and Ag) developed in BIM can be used to treat different hot working tool materials include Nickel based material and molybdenum base refractory materials.

The tools can be surface modified by nitrogen and/carbon and they can also be deposited a lubrication or hard layer on the surface to enhance the performance of the tools. These technologies have been widely used on improving the performance of stainless steel and low carbon steel materials.

Partner AIN:

AIN would like to transfer the technology to manufacturing industries hosting processes such as sintering, hot forging, hot stamping, high speed machining. The transfer of technology will be carried out mainly under contract research funded by the beneficiary company.

4.4 Ancillary devices for integrated Micro-FAST system

Partner FRA-ILT – Laser die-cleaning system:

The developed automated prototype for laser-die cleaning can be easily integrated in the Micro-FAST machine and can be adapted to other micro-manufacturing production chains, allowing the cleaning and consequently increasing the life of the forming tools.

Partner MIC: Powder feeding system for micro-/nano-manufacturing applications

The developed automated prototype is suitable for a number of applications where the precision feeding of small amounts of powder is required, due to demonstrated reliability of the feeder for filling process with different kind of powders: besides the sintering of powder to manufacture micro-components, the feeder is suitable also for other techniques like hot pressing for pharmaceutical applications and micro-moulding where high accuracy is required.

Partner UOS: Inline forming-tool inspection method

The real power lies within the software developed for this inspection system. Indeed the plug-in structure has been packed as a framework that can be used in other applications. For immediate impact, the inspection module (including the hardware) has been attracting attentions of some academics and engineers. What makes the framework different is that it provides a complete work flow of data sampling, motion control, evaluation and visualization while maintaining maximum flexibility. For example, nowadays a typical technician may sample data from a CMM machine/scanner, then transfer the data into Matlab or other commercial applications to process that data, then, transfer the processed result for visualization via another software. The framework built in this project allows algorithms to be implemented with C#/VB, drawing realized in OpenGL. It has shown many possibilities in computational geometry. Moreover, as long as the hardware is properly built they can be used in the framework seamlessly. To date, several virtual devices have been built and simulations conducted based on these.

The system can be extended to general tool inspection applications. With plug-in capabilities of the software developed, adding other processing heads, e.g. high-speed cutter and/or printing heads, a hybrid micro-manufacturing machine with 3D printing capability and auto-inspection could be developed.

The inspection method will be disseminated via further conferences or workshops, and the system will be demonstrated to potential end-users. It is hoped that by showing the system's capability and our expertise, UOS could develop services for designing and constructing customized systems for tool and component inspections for micro-manufacturing industry, and for metal-fabrication industry in general.

Partner IPU: Ejection system

The manual ejection station performs nicely in the Micro-FAST setup. However it is an extra process step. If instead the ejection could be performed in-line with minimum risk of material stuck in the die the process chain could be simplified. There besides the manual ejection station, IPU has been exploring a use of an pre-stressed expanding die for sintering. This has been performed with traditional heating in IPU laboratories. The concept has shown promising results, and IPU is involved in an industrial PhD project which continues to explore this concept.

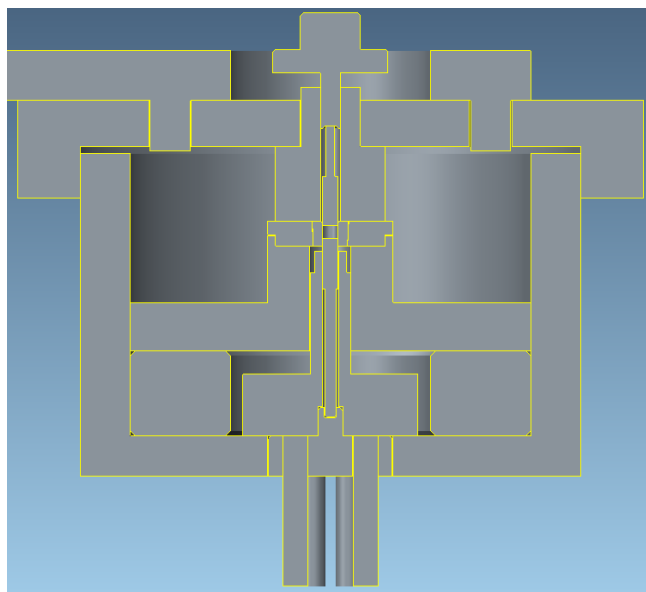

Fig. 27: Cross section of CAD model of the tool for compression and expanding the sintering die

The potential use of the technique with a pre-stressed die combined with the electric current conduction heating developed in the Micro-FAST project is a fast process, which minimizes the wear and sticktion in the die during sintering while a high productivity can be maintained.

4.5 Miniaturized components

Watch crown (ETA)

Today a crown is manufactured with conventional technics like cold and hot forming combined with a lot of machining operations and surface finishing as well as polishing operations. For crown in ceramic, conventional technics like pressing, debinding, sintering, machining, grinding, surface finishing as well as polishing are used for its manufacturing. The materials used today for the crown is mainly a metal alloy, usually stainless steels. Only a few models of very expensive watch could have a crown in ceramic. Potentially in the future, with Micro-Fast machine, ETA will be capable to manufacture more crowns in ceramic with the best aesthetic quality.

As aesthetic product the crown has a low batch quantity, but a lot of different designs. Micro-FAST machine/process will allow the required flexibility for changing the tooling and adapting the process after each 20'000 manufactured parts (average quantity).

Potentially ETA will be capable to produce about 600'000 pieces per year for one Micro-Fast machine, (roughly speaking about 3000 pieces per day) with significant time and cost savings respect to current production method.

Turbine (DIGR)

The main market of MicroFAST titanium cooling turbine is the segment plug-in hybrid electric vehicle (PHEVs) of the PEVs. The range extender is applied as auxiliary power unit (APU) in a particular configuration named "series hybrids" or "concept H" (having function of battery charge, not rotating the vehicle's drive wheels). The PHEVs market growth has been impressive in last decade: 300 units in 2010, to 9000 in 2011, 60,000 in 2012, 222000 in 2015, 279000 in 2016 (e.g. Chevrolet Volt, BMWi3, Cadillac ESR, Fisker Karma, Nissan). The market research "Range Extenders for Electric Vehicles Land, Water & Air 2017-2027" indicate a forecast of 9 Millions of PHEVs within 2027, almost equipped with an APU. In this scenario, MicroFAST will allow DIGR to approach the market with a highly competitive solution, based on the redesign and downsizing a two strokes 125cc traction engine, that will be commercialized at half price of best products actually on market (e.g. BMWi3).

DIGR will explore additional exploitations of the titanium cooling turbine on two strokes engines will be proposed for competition motorbikes (**motocross, enduro, supermotard**) and karts, for **ski-doos** and for **small aircrafts and hybrid aircrafts**. In particular DIGR considers highly strategic to approach the kart market as it is estimated €57.5 million in annual sales and more than €500 million in aftermarket, with a yearly production estimated of about 100000 -150000 karts.

More in general, the MicroFAST technology will allow DIGR to produce and commercialise, at a competitive price, large batches of micro/small titanium parts for motorsport, automotive and aeronautic sectors. In fact, the forging or the casting of complex shaped titanium parts is critical and the cutting from solid, the best solution, it is very expensive.

Piezo-actuator (CED)

Cedrat Technologies main product is the APA®, Amplified Piezoelectric Actuator, which allows a larger stroke than conventional piezoelectric actuator with very good amplification efficiency. There are two main components for these actuators: the piezoelectric ceramic (converts electricity in displacement) and the shell (amplifies and converts the displacement).

Currently the shell is made using EDM process (electric discharge machining), a very precise process (compared to mass production process), well suited for the specific shape of CED products

and which preserves the mechanical properties of the steel, but EDM is very expensive and not suited for big series application. With Micro-FAST production process Cedrat Technologies targeted to develop a process precise enough for the high demanding integration of the shell, cheap enough for series production and which preserves the mechanical properties of the steel or other stress compliant material: potentially the production of the piezo-actuator by Micro-FAST will allow the series production of this component up to thousands of pieces/year at much lower price than the actual production system (not suitable for the series production) achieving a very competitive product in the market.