



**Project: FP7-604416 DEEPEN  
FINAL REPORT**

	Executive Summary .....	2
1	Context and objectives .....	3
1.1	Objectives.....	3
1.2	Socio-economic and technological context and drivers .....	4
2	Main Science and Technology Results .....	7
2.1	Introduction and Overview of Achievements.....	7
2.2	DEEPEN III-V Semiconductor Parameter Database .....	8
2.3	Analysis of Charge Transport Models .....	12
2.4	Multiscale Simulation Environment .....	14
2.5	Application to Advanced CMOS Devices.....	17
2.6	Application and Validation for III-N LED Devices.....	19
3	Potential Impact, Dissemination and Exploitation .....	27
3.1	Potential Impact .....	27
3.2	DEEPEN Dissemination Activities .....	28
3.3	Exploitation of Results.....	33

## Executive Summary

The path from academic research to synthesis of advanced engineering systems relies increasingly on using computational simulation techniques to gain insight on the system, to steer improvements, and to validate the final design. DEEPEN directly addresses this challenge, bringing together leading groups with expertise in simulation, and in its application to device design and optimization, for the purpose of developing an integrated open source multiscale simulation environment, targeted at problems common to future nanoscale electronic and photonic devices. New device simulators require an **atomic-scale description of selected critical regions** of a transistor or LED to capture details otherwise inaccessible. They must also resolve the **considerable uncertainty in many critical parameters** required for device optimisation.

We have targeted these two key requirements for advanced simulation. Firstly, we have developed and released a **materials parameter database** for III-V binaries and ternary alloys, covering from *ab-initio* methods through to empirical atomistic (tight-binding) and continuum (**k.p** and effective mass) models. Secondly, we have released and are supporting demonstration software and **open source interfaces** in a device modelling framework, linking physical models from *ab-initio* electronic structure models through to the macroscopic level, and targeting not just materials physics simulations but also their use in the actual design and optimization of engineering devices. The interface between models is designed to be open and re-usable with a wide range of existing codes. An open source Common Data Format (CDF) has been defined and implemented for the III-V materials relevant to DEEPEN. Future code distribution is being supported through TiberLAB's existing support environment, [www.tibercad.org](http://www.tibercad.org) and through the project web site [www.nmp-deepen.eu](http://www.nmp-deepen.eu).

The DEEPEN environment has been used to provide new insights as well as improved device design capability. For **electronic devices**, exemplary technology computer-aided design (TCAD) setups have been developed and validated for a range of transistor structures that reflect modern technology and device concepts. As example, the influence of source-to-drain tunnelling on electrical device performance has been investigated, where the device core is treated using the non-equilibrium Green's function (NEGF) method, confirming the usability of the models and providing critical information on InGaAs device performance.

For **photonic devices**, calculations using the DEEPEN parameter database confirmed the importance of carrier localisation due to random alloy fluctuations, in excellent agreement with DEEPEN and literature optical measurements. The NEGF method was applied to address the influence of alloy disorder on current flow in unipolar InGaN multi-quantum well structures. In practice, full NEGF calculations are too expensive for realistic III-N structures, but the NEGF results have guided the development of quasi-3D models that were validated and used e.g. for detailed analysis of electroluminescence in nanowire LEDs.

The project has emphasized **aggressive dissemination** to maximize impact, including organization of Training Schools and a Workshop, as well as release of the DEEPEN open-source environment. DEEPEN also worked closely with the other projects in the European Multiscale Modelling Cluster: wide uptake of open source multiscale modelling is best enabled by common standards and processes to enhance code modularity and reusability.

Overall, the project has **significant potential economic and societal impact**. The outcomes of DEEPEN contribute significantly to European innovation at several levels. Firstly, the DEEPEN TCAD tools can drive the research agenda in nanoscience and nanotechnology, both for DEEPEN partners and in the wider community. The tools developed are also valuable to modelling systems providers such as DEEPEN partners TiberLAB and Synopsys, both of whom are exploiting DEEPEN developments in their product portfolio. Finally, Europe needs jobs higher up in the value chain. This implies the capability to design superior electronic and photonic devices and systems. The multiscale simulation environment developed in DEEPEN and the participation of OSRAM in DEEPEN are key enablers to achieve this goal: OSRAM's current significant expansion in Regensburg is underpinned by projects such as DEEPEN. Overall, DEEPEN aims to significantly strengthen European competitiveness, with clear routes to exploitation of the technology.

# 1 Context and objectives

The concept of the DEEPEN project is very simple. Given the growing demands of the information society, there is a strong need for new energy-efficient nanoscale electronic and photonic devices. Nanowires, nanoparticle arrays and quantum wells are just some of the large ensemble of new structures proposed for future device applications. Surprisingly however, there remains considerable uncertainty in many critical parameters required for the optimisation of such devices. As the scale of future devices shrinks further down, quantum and statistical effects also become increasingly important, as well as the need for new materials, and a description of the device coupling to higher dimensions.

DEEPEN targeted the development of an integrated multi-scale modelling environment, particularly suited for studying electronic, transport and optical properties of novel nanoscale devices, coherently combining state-of-the-art existing methods as well as developing new methodologies, all integrated within a **multiscale** and **multimodel** framework. The nanoscale devices being studied require models that go beyond approaches strictly related to material science. The new models need to address the challenging problem of predicting quantitatively electronic structure, optical properties and quantum phenomena **at the nanoscale**. Most models used in device simulation can be considered as material models. However new nanoscale devices are not accurately described using bulk properties since atomistic details become of central importance. At present, the treatment of atomistic details are mostly applied for research purposes only, and multiscale integration has been limited to material science problems. The description at a microscopic scale of selected critical regions of a device, down to its very basic atomistic ingredients, is a distinctive feature that new device simulators should include in order to capture details otherwise inaccessible.

The DEEPEN consortium worked to address this challenge, building on the expertise both of the academic and industrial partners to develop an open source multiscale simulation environment, to address device properties across a range of scales, using a harmonized approach to interface design, which will support interfacing to commercially available simulation packages. DEEPEN brought together leading European groups with expertise not just in simulation, but also in its application to device design and optimization. It built on Tyndall (Tyndall-UCC) and ETH Zurich (ETHZ) expertise in material and device properties, with experimental input from Paul Drude Institute (FVB-PDI) critical for validation of the multiscale models developed. Industry partners included a key multiscale modelling system provider (TiberLAB; TIBER), a leading TCAD simulation provider (Synopsys; SNPS) and an industrial end-user (OSRAM) who provided experimental validation and tested the simulation environment for device design and investigation.

## 1.1 Objectives

The major objective of DEEPEN was to develop an **integrated multiscale simulation capability** for predictive design of novel materials and nanostructures, **targeted at two of the most important present device challenges**, namely future CMOS and future energy-efficient light sources. The nanoscale **electronic and photonic** devices to be studied require models that go beyond approaches strictly related to material science, with many model requirements common to both types of devices. To this end, first principles calculations were undertaken to establish accurate parameters for empirical methods. With transport key to electrically driven devices, DEEPEN developed approaches to give **loose** and **tight coupling** between transport models from first-principles through to drift-diffusion, with rigorous investigations of the coupling between scales. These linked transport models are equally relevant to the design both of electronic and of photonic devices.

The **testing and validation of the code** was based on comparison with a range of experimental data, including data from the literature for nanoscale transistors and data generated by FVB-PDI and OSRAM on specially designed nitride-based materials and devices. Overall, detailed device studies formed an important part of the validation and application in the final stages of the DEEPEN project. Furthermore, SNPS and OSRAM provided critical input regarding the requirements for useful packages and interfaces.

The final objective of the project was to ensure the longer term **take-up and exploitation** of the multiscale simulator. This objective was addressed through:

- The organisation in year 3 of a CECAM Workshop on Multiscale Simulation<sup>1</sup>, including a plugfest, and of an International Workshop at the end of year 3, targeted at semiconductor materials and device simulation researchers<sup>2</sup>
- The release and support of demonstration software and the open source interfaces.
- Participation in the European Materials Modeling Council<sup>3</sup>
- Participation also in a cluster including members from all other projects funded under the Call topic (NMP-2013-1.4-1; FP7-NMP-2013-SMALL-7), with the aim to create the standards and processes required to enhance code modularity and reusability
- The inclusion of the three leading industry partners in DEEPEN, namely an SME specializing in multi-scale simulation (TIBER), a major TCAD provider (SNPS) and a major designer and manufacturer of solid state lighting (OSRAM).
- Support both during and following the project for the simulation environment developed in DEEPEN being provided through the project web site and through TIBER's existing support environment, [www.tibercad.org](http://www.tibercad.org).

The project's OS environment is released under the GNU Lesser General Public License (GNU LGPL), ensuring that the core of the multiscale environment together with all its Application Programming Interfaces (APIs) can be distributed and even modified freely. This provides a clear route for dissemination, while individual partners are also further exploiting the code and expertise which they have developed, including its use by TIBER and SNPS in emerging TCAD products and OSRAM use in future product and device design.

## 1.2 Socio-economic and technological context and drivers

The exponential decrease in feature size and related growth in the number of transistors per chip, described by Moore's Law, is driving major changes in society, including as examples the exponential growth in the internet and communications, the drive towards ubiquitous sensors and Internet of Things, and the rapid growth in technologies to deliver personalized health monitoring, diagnostics and treatment. Each of these application areas creates the demand for further exponential growth in processing power. Although the end of Moore's Law has long been predicted, there are still major gains to be achieved from the evolution and downsizing of existing technologies, including further reductions in feature scale, the adoption of new channel materials such as InGaAs or InAlAs, and the introduction e.g. of device gate architectures which take explicit advantage of the nanoscale material structuring which is now becoming feasible<sup>4</sup>.

In parallel, the evolution of optical devices is creating many opportunities and demands. There is a strong drive to replace single light sources (as light bulb) by arrays of miniature light sources (as LED arrays). LED arrays are much more flexible, efficient and reliable than single sources opening wide applications in smart lighting<sup>5</sup>. LEDs bring many advantages compared to incandescent lamps and are poised to also deliver significant efficiency savings and wider societal benefits compared to compact fluorescent lamps (see Fig. 1.1). The future growth of LED markets nevertheless faces many challenges. The best current white-light LEDs are based on III-N materials. Although they have a high efficiency at low drive current, their efficiency decreases strongly with increasing drive current. Novel approaches are therefore required if efficient LEDs are to become ubiquitous, with particular advantages proposed for III-N nanowires as efficient optical emitters across a broad spectral range<sup>6</sup>. These structures could lead to bright amber and red LEDs based on group-III-nitrides. Such

---

<sup>1</sup> <https://www.cecam.org/workshop-1255.html>

<sup>2</sup> <http://www.tmcuk.org/conferences/Euro-TMCSII>

<sup>3</sup> <https://emmc.info/>

<sup>4</sup> J.P. Colinge *et al.*, *Nature Nanotechnology* 5, 225 - 229 (2010)

<sup>5</sup> See e.g. Smart Lighting 2013 Intelligent & Dynamic Lighting, May 14-15, Frankfurt, Germany

<http://www.smartlighting.org/sl2013/>

<sup>6</sup> T. Kuykendall *et al.*, *Nature Materials* 6, 951 (2007); S. Li and A. Waag, *J. Appl. Phys.* **111**, 071101 (2012).

LEDs would not contain any toxic elements like arsenic and phosphorus, which would be a clear advantage over current standard technology.

The use of nanostructured materials is clearly well established for electronic devices, and is emerging as a key requirement for small, efficient and low cost active LED technologies. The modeling of such structures was the key goal of DEEPEN. The simulation of light emitting and of electronic nanostructured materials share many common tasks and challenges. Many parameters, over several length scales, need to be varied and optimized in the design and development of such devices and components. The synthesis of advanced structures requires the use of computational simulation techniques to gain insight, to steer improvements, and to validate the final design<sup>7</sup>. The big challenge and still at its infancy is to simulate phenomena that take place at many and fully interacting scales at the same time – for example on a spatial scale that ranges over approximately six orders of magnitude in some of the devices considered in DEEPEN, from nanometre-scale active regions to millimetre and centimetre-scale device structures.

In electronics, nanotechnology and nanodevice evolution has been dominated over the last decade by aggressive device scaling in the sub-100nm zone and by the related cost-effectiveness of silicon technology. Today, silicon and also SiGe channel based nanometre CMOS is the single recognized solution for reliable circuits and systems. However, in order to meet the challenges of sub-10nm gate length, CMOS will have to switch to new channel materials including transport enhancement techniques like strained devices and bandgap engineering. For this, TCAD based investigation of the new device structures is mandatory. One of the most important Figures of Merit (FOM) of CMOS transistors is the on-off current ratio  $I_{on}/I_{off}$ , where the off-current for very short gate length is partly determined by source-drain tunneling mechanisms. Currently TCAD is not capable of calculating source-drain tunneling. For daily TCAD application, there is now an urgent requirement for model approaches like non-local tunneling and density gradient models that would allow to set up a lumped TCAD model for source-drain tunneling which will then need to be tested and calibrated to ‘first principle tools in a hierarchical way.

Many different electronic and transport phenomena across a range of length scales are therefore involved both in CMOS design and in maximising the optical efficiency of LEDs, which makes it difficult to adapt a structured approach to device design, analysis and optimisation. For example, one of the factors limiting the high power operation of white LEDs is carrier transport between neighbouring quantum wells in the active region. Although this current should ideally include an optimised tunnelling component, no detailed model has yet been presented as to the dependence of this tunnelling current on the actual device structure. The operation of actual electronic and photonic devices depends not just on such nano-details but also on many other factors across a range of length scales.

The two examples above highlight that carrier tunnelling at the atomistic level can dominate the device-level properties both of electronic and photonic devices. This then makes it critically important that future device models include the key physics across the full range of length scales, in particular when self-consistency becomes important, as is often

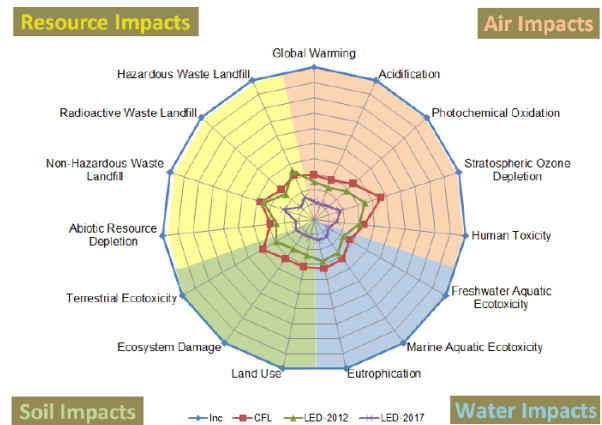

**Figure 1.1:** Environmental impact of LEDs compared to compact fluorescent lamps normalized to the values for incandescent light bulbs. (Source: US Department of Energy SSL workshop, Long Beach, CA, 2013)

<sup>7</sup> Simulation Based Engineering Science - An NSF Blue Ribbon Report. Can be downloaded from [www.ticam.utexas.edu/events/SBES\\_Final\\_Report.pdf](http://www.ticam.utexas.edu/events/SBES_Final_Report.pdf).

the case when dealing with the potential associated with a non-equilibrium distribution of charged carriers.

The reliable modeling of multi-scale engineering systems of realistic complexity, via the development of efficient and accurate modeling techniques, requires the insight obtained from physical modeling<sup>8</sup>. While many physical processes are well understood and may be simulated independently, complex design and synthesis problems, involving the interaction between several scales in space and time, currently remain out of reach. Even if the available computer power follows Moore's law and continues to grow exponentially, there are no prospects that we will in the foreseeable future be able by 'brute force' to solve the large multi-scale problems in functional material and device design.

An array of tools exist which can be used for modelling at different length scales (see Fig. 1.2). A wide range of well-established packages are available both at the smallest length scales, where ~100's of atoms can be treated using **ab-initio first-principles** packages<sup>9,10,11</sup> and also at macroscopic scales, where **continuum** methods are particularly effective<sup>12</sup>. There are in addition a smaller number of packages available, such as OMEN, which can use **empirical atomistic** methods to treat up to the order of several millions of atoms, the scaling range over which quantum effects are typically important in actual devices. Fundamental new ideas and tools are needed to link these elements together and so to advance computational engineering to achieve what engineering is really about: the control, design and synthesis of realistic systems. The challenge now is to develop a suitable set of tools, using a common environment, to link these different scales successfully together. This tool set needs to be robust and flexible. Different approaches will be needed to ensure consistency in different problems between scales. No one approach can be expected to reliably predict and analyse the impact that atom-scale features at the heart of a device can have on its overall performance and optimisation in all cases. The **main goal** of DEEPEN was to build, validate and implement such a **multiscale simulation tool**, targeted at the design and optimisation of critical photonic and electronic devices based on novel nanostructured materials.

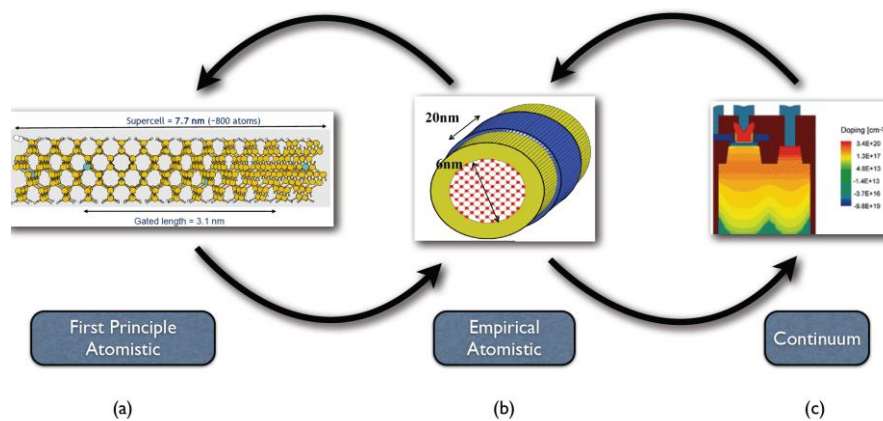

**Figure 1.2:** Different scales addressable by different codes: (a) First-principles codes such as **TiMeS** can treat hundreds of atoms; (b) empirical atomistic codes such as **OMEN** are needed to treat the details of millions of atoms; (c) A full device structure treated using a continuum model such as **Sentaurus Device**.

<sup>8</sup> Final Report, Second DOE Workshop on Multiscale Problems, Broomfield, Colorado, USA, July 20-22, 2004, [http](http://www.doe.gov)

<sup>9</sup> X. Gonze *et al.*, "First-principles computation of material properties: the ABINIT software project", *Computational Materials Science* 25, 478-492 (2002).

<sup>10</sup> Vienna ab initio simulation package [www.vasp.at](http://www.vasp.at); G. Kresse and J. Furthmüller, "Efficient iterative schemes for ab initio total-energy calculations using a plane-wave basis set", *Phys. Rev. B* 54, 11169–11186 (1996)

<sup>11</sup> OpenMX web site. T. Ozaki, H. Kino, J. Yu, M. J. Han, N. Kobayashi, M. Ohfuti, F. Ishii, T. Ohwaki, H. Weng, <http://www.openmx-square.org/>.

<sup>12</sup> e.g. <http://www.synopsys.com/Tools/TCAD/DeviceSimulation/Pages/SentaurusDevice.aspx>

## 2 Main Science and Technology Results

### 2.1 Introduction and Overview of Achievements

DEEPEN brought together leading groups with expertise in simulation, and in its application to device design and optimization, for the purpose of developing an integrated open source multiscale simulation environment, targeted at problems common to future nanoscale electronic and photonic devices. New device simulators require an atomic-scale description of selected critical regions of a transistor or LED to capture details otherwise inaccessible. They must also resolve the considerable uncertainty in many critical parameters required for device optimisation. DEEPEN has addressed both these issues, coherently combining state-of-the-art existing methods and developing new methodologies, integrated within a multiscale framework spanning from first-principles electronic models through to continuum electronic device models.

DEEPEN developed a library for material properties, and also models to treat how these material properties change on nanometre length scales, as described below in Sec. 2.2. To this end, different methods were linked and coupled which have already proved very effective in describing phenomena at different levels of approximation and at different length scales. Section 2.3 describes some of the models which were coupled, while Sec. 2.4 describes the Open Source environment developed for linking and coupling. The linked methods have been used to provide new insights as well as improved device design capability, as described for electronic devices in Sec. 2.5 and for photonic devices (III-N LEDs) in Sec. 2.6.

The simulations developed in DEEPEN can treat critical device regions using *ab-initio* density functional theory (DFT), or, for larger critical regions, using the semi-empirical tight-binding (TB) and envelope function methods. The interface between models is designed to be open and re-usable with a wide range of existing codes. An open source Common Data Format (CDF) has been defined and implemented for the III-V materials relevant to DEEPEN.

Significant effort was devoted to building this material parameter dataset, and then to incorporate the full finalised parameter set into the open source database for III-V binaries and selected ternary alloys. The parameters are available for open-source download from the TiberCAD website and as deliverable D2.5 from the DEEPEN website<sup>13</sup>, with most of the parameters also disseminated by DEEPEN partners through peer-reviewed publication.

Further effort focussed on code coupling and linking, and also on the development and validation of the DEEPEN open source interface (OSI) and of the multiscale simulation environment which it supports. A link to a video demonstration of the OSI is available on the DEEPEN website<sup>14</sup>, while the fully tested OSI is available for use through the TiberCAD website.

The DEEPEN multiscale environment targets application both to electronic and photonic devices. Figure 2.1 shows a workflow overviewing the different types of models linked through the DEEPEN OSI for advanced CMOS design.

Significant testing and validation of the interface was undertaken during the project. For **electronic devices**, TCAD simulation setups have been developed and validated for FinFET, thin-film DG-FETs (Double-Gate Field-Effect Transistor), and FD-SG-FETs (Fully Depleted Single-Gate Field-Effect Transistors) that reflect modern technology and device concepts, using parameters from the DEEPEN database and CDF scripts developed in DEEPEN. As example, the influence of source-to-drain tunnelling on electrical device performance has been investigated, using a TCAD setup where the device core is treated using the non-equilibrium Green's function (NEGF) method, confirming both the usability of the models and also providing critical information on the performance of InGaAs devices.

---

<sup>13</sup> <http://www.nmp-deepen.eu/public-deliverables>

<sup>14</sup> <https://youtu.be/o38wD3j7qiU>

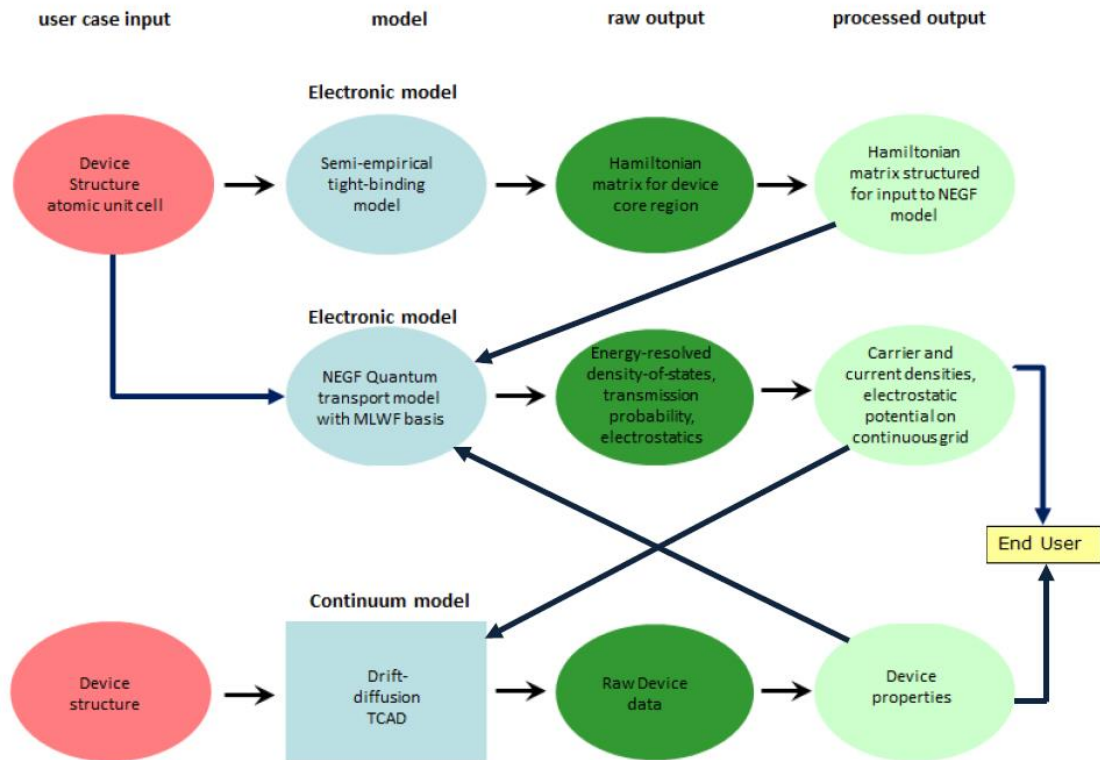

**Figure 2.1:** Workflow showing the different types of models linked through the DEEPEN OSI for advanced CMOS design

For **photonic devices**, calculations using the DEEPEN tight-binding parameter set confirmed the importance of carrier localisation due to random alloy fluctuations, in excellent agreement with DEEPEN and literature optical measurements. The NEGF method was applied to address the influence of alloy disorder on current flow in unipolar InGaN multi-quantum well structures. In practice, full NEGF calculations prove very expensive for realistic III-N structures, but the NEGF results, supported by experimental analysis, enabled the development of quasi-3D models that were validated and used for instance for the detailed analysis of electroluminescence in nanowire LEDs.

DEEPEN emphasizes aggressive dissemination of results to maximize impact. As part of this effort, we interacted strongly with other projects in the European Multiscale Modelling Cluster, aiming at creating the standards and processes required to enhance code modularity and reusability. DEEPEN led organisation of the main cluster event during the final year of the project, a Workshop on “Multiscale Simulation: from Materials through to Industrial Usage” in September 2016. To disseminate the results of DEEPEN to the relevant research community, DEEPEN also hosted Euro-TMCS II Theory, Modelling and Computational Methods for Semiconductors, in December 2016. Further details of dissemination and of steps to maximise impact are described in the next section of this report (Sec. 3).

## 2.2 DEEPEN III-V Semiconductor Parameter Database

A major aim of DEEPEN was the generation of a database from *ab-initio* computed band structure of structural, mechanical, physical and piezoelectric parameters for both unstrained and strained III-V binaries and ternary alloys of InGaAs and of wurtzite (In,Ga,Al)N. The set of calculated material parameters was integrated into the DEEPEN multi-scale simulation framework, which provides parametric coupling between *ab-initio* atomistic simulation tools and drift-diffusion simulators (Sentaurus Device, TiberCAD), and have also been used within



the project for validation and calibration against experimental data on III-N heterostructures and nanowires. The band structures and material parameters are the input for  $\mathbf{k}\cdot\mathbf{p}$  and tight-binding model-based quantum transport solvers. A list of the corresponding parameters has been made available on the DEEPEN website<sup>15</sup> and is also available on the TiberCAD webpage<sup>16</sup> for download as a HDF5 file. Scripts used for the extraction of key parameters such as band structures, energies, and effective masses are also publicly available at the DEEPEN<sup>17</sup> and TiberCAD websites.

## 2.2.1 Basic structure parameters for unstrained $\text{In}_x\text{Ga}_{1-x}\text{As}$ alloys

The values of the lattice constants of  $\text{In}_x\text{Ga}_{1-x}\text{As}$  alloys with  $x=0, 0.25, 0.50, 0.53, 0.75,$  and  $1.0$  were calculated with the (electronic) quantum density functional plane-wave pseudopotential code VASP using hybrid (HSE06) functionals. Experimental and LDA-calculated values were benchmarked against these HSE06-based lattice parameters. With the same method, the most important band structure parameters of GaAs, InAs, and InGaAs compounds have been obtained, namely (i) the band gap energy ( $E_g$ ) defined as the difference between the top valence band and the bottom of the conduction band at the  $\Gamma$ -point, (ii) two higher conduction band energies ( $E_X$  and  $E_L$ ) at the  $X$  and  $L$ -valleys defined with respect to the top of the valence band, and (iii) the spin-orbit splitting ( $\Delta_{\text{so}}$ ) between the top and split-off valence bands. The compositional dependence of all the band structure parameters was characterized with a compositional bowing parameter. Electron effective masses and the related non-parabolicity parameters of the conduction band for GaAs, InAs, and  $\text{In}_x\text{Ga}_{1-x}\text{As}$ , as well as heavy, light, and split-off hole effective masses for different band valleys and crystallographic directions were calculated with hybrid (HSE06) functionals taking into account the spin-orbit coupling.

### *Deformation potentials for band parameters of $\text{In}_x\text{Ga}_{1-x}\text{As}$ alloys*

In the linear approximation, any deformation of the  $\text{In}_x\text{Ga}_{1-x}\text{As}$  alloy structure can be represented as a combination of the hydrostatic and shear deformations. To correctly describe the hydrostatic deformation effect on the band gap, the hydrostatic deformation potential,  $a_g$ , was calculated with VASP. Besides the hydrostatic strain effect on the conduction and valence bands at the  $\Gamma$ -point, the hydrostatic deformation also shifts the higher conduction band energies at the  $X$  and  $L$ -valleys with respect to the top of the valence bands at the  $\Gamma$ -point. The corresponding hydrostatic deformation potentials,  $a_X$  and  $a_L$ , were computed together with the corresponding compositional bowing parameters. The shear deformations which cause both conduction and valence band splitting have been quantified by the corresponding shear deformation potentials  $\Xi_{u,X}$ ,  $\Xi_{u,L}$ ,  $b$ , and  $d$  according to  $\mathbf{k}\cdot\mathbf{p}$  model conventions. As a result, the deformation potential values can be directly used within the framework of a  $\mathbf{k}\cdot\mathbf{p}$  model or a tight-binding model.

The conduction band hydrostatic deformation potentials,  $a_g$ ,  $a_X$  and  $a_L$  can be expressed as  $a_g = \Xi_{d,\Gamma} - a_V$  and  $a_C = \Xi_{d,C} + \Xi_{u,C}/3 - a_V$ , where  $C = L$  or  $X$ ,  $\Xi_{d,\Gamma}$ ,  $\Xi_{d,C}$ , and  $\Xi_{u,C}$  are the deformation potentials as defined by Herring and Vogt<sup>18</sup>, and  $a_V$  is the hydrostatic deformation potential for the average of the three top valence bands at the  $\Gamma$ -point. One key result of our analysis has been that the electronic states at the  $\Gamma$  and  $L$  ( $\Gamma$  and  $X$ ) valleys of the face-centered cubic Brillouin zone of  $\text{In}_x\text{Ga}_{1-x}\text{As}$  alloys are not affected by the shear strain type I (type II), being protected by symmetry, i.e.,  $\Xi_{u,\Gamma} = 0$ . Figure 2.2 compares the calculated variation of the hydrostatic deformation potential  $a_g$  with the experimental variation previously reported in the literature. It can be seen that theory predicts a negative bowing of  $a_g$  compared to the positive bowing reported in the literature. Our analysis identified the

<sup>15</sup> [http://www.nmp-deepen.eu/contentfiles/DEEPEN\\_FP7\\_604416\\_D2\\_5\\_Report\\_30\\_Months\\_ETHZ\\_TNI\\_DEEPEN\\_Website\\_submit.pdf](http://www.nmp-deepen.eu/contentfiles/DEEPEN_FP7_604416_D2_5_Report_30_Months_ETHZ_TNI_DEEPEN_Website_submit.pdf)

<sup>16</sup> <http://www.tiberCAD.org/content/deepen>

<sup>17</sup> <http://www.nmp-deepen.eu/public-deliverables>

<sup>18</sup> C. Herring and E. Vogt, Phys. Rev. **101**, 944 (1956)

origin of this discrepancy as being due to inaccuracies in some of the intermediate parameters, such as elastic constants, assumed in the experimental analysis.

These and other findings were published in Khomyakov *et al*<sup>19</sup>. The three  $X$  (four  $L$ ) valleys are split by the type I (type II) shear strain into three singlets (doublets) with a shift of  $\Delta E_X = 0$  and  $\Delta E_X = \pm \Xi_{u,x} |\epsilon|$  ( $\Delta E_L = \pm 2 \Xi_{u,c} |\epsilon|/3$ ) with respect to the averaged conduction band energy,  $\epsilon$  being the strain parameter. The strain effect on the electron and hole effective masses can be quantified, in general, within the  $\mathbf{k}\cdot\mathbf{p}$  model using the hydrostatic and shear deformation potentials as well as other material parameters that we have calculated.

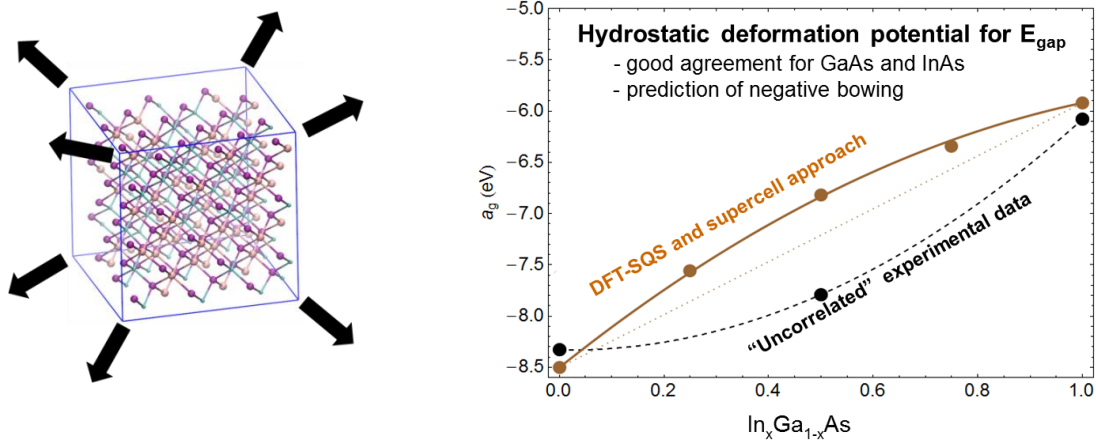

**Figure 2.2:** Strain dependence of the hydrostatic deformation potential for  $E_{\text{gap}}$  of InGaAs.

### **Mechanical properties of $\text{In}_x\text{Ga}_{1-x}\text{As}$ alloys**

All parameter values for mechanical properties such as elastic constants, bulk modulus and Poisson ratios for the  $\text{In}_x\text{Ga}_{1-x}\text{As}$  ternary alloy with alloy composition  $x=0, 0.5$  and  $1.0$  were derived, including the values of the compositional bowing parameter.

### **Ab-initio derived tight-binding parameters as used in the TB code OMEN**

Based on the DFT data, tight-binding parameters were derived for GaAs and InAs in the nearest-neighbour  $sp^3d^5s^*$  basis with spin-orbit coupling. A MATLAB code has been developed for that purpose that takes the calculated targets as a reference and adjusts 31 tight-binding parameters per material to best reproduce the DFT inputs. A least square optimizer was used as the fitting algorithm. These new TB parameters allow more accurate transport simulations of switching devices with III-V channels.

### **2.2.2 Mechanical properties of III-Nitrides and III-V materials**

Hybrid functional (HSE06) DFT calculations have been performed to extract second-order elastic constants of wurtzite and zincblende III-Nitrides GaN, InN and AlN. The obtained theoretical data is in very good agreement with available experimental data. Furthermore, internal strain parameters have been determined from the DFT data for both wurtzite and zincblende nitride systems. The applied approach has been extended to other III-V zinc blende materials, extracting here also third-order elastic constants and internal strain parameters. Using the derived ab-initio (second- and third-order) elastic constants along with internal strain parameters allowed us to develop improved valence force field (VFF) models. Here, the required VFF parameters are extracted directly, without fitting procedure, from the elastic constants and the internal strain parameters of the material.

<sup>19</sup> P.A. Khomyakov, M. Luisier and A. Schenk, Appl. Phys. Lett. **107**, 062104 (2015)

### Ab-initio derived tight-binding parameters for III-Nitrides

To circumvent the band gap problem of standard LDA-DFT, we have used HSE06-DFT to obtain bulk band structures for wurtzite and zincblende InN, GaN and AlN systems, presenting the targets for our tight-binding models. These developed models, especially the models for the wurtzite systems, formed the backbone for the experimental validation studies of III-N LEDs described in Section 2.6. Here, tight-binding parameters for nearest neighbor  $sp^3$  and  $sp^3d^5s^*$  parameterizations have been extracted. An example for the comparison between HSE06-DFT and determined tight-binding band structure is given in Figure 2.3 (left) for InN.

### Band offsets, band gap and band edge bowing parameters for III-Nitrides

Using the above developed tight-binding models in conjunction with the VFF models and local polarization theory that we also developed (see below), composition dependent band gap and band edge bowing parameters for wurtzite InGaN, AlGaN and AlInN alloys have been extracted. The obtained results were benchmarked against literature HSE-DFT and experimental data, showing excellent agreement between theory and experiment over the full composition range. An example is shown in Figure 2.3 (right) for InGaN bulk systems. Our data reveals that while AlGaN behaves almost like a “conventional” III-V alloy where the band gap bowing can be described by a single composition *independent* bowing parameter,

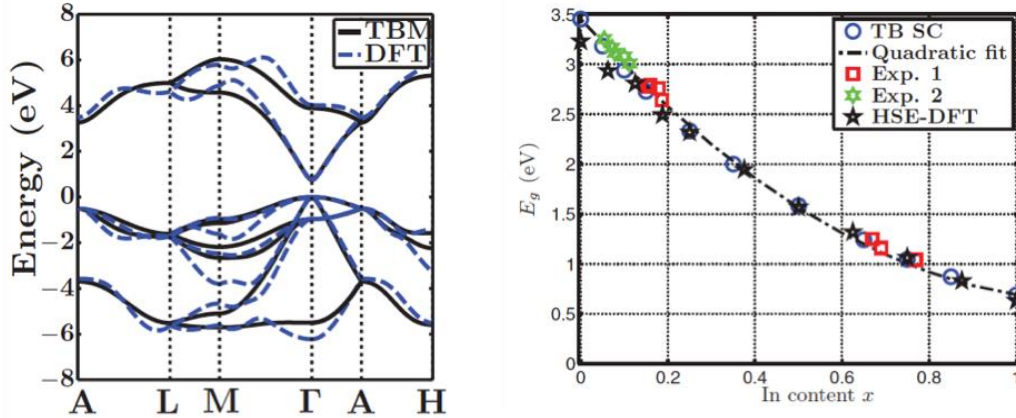

**Figure 2.3:** Left: Electronic band structure for wurtzite InN. Blue dashed lines show the HSE06-DFT data; the black solid lines show the tight-binding data. Right: Energy gap variation of wurtzite  $\text{In}_x\text{Ga}_{1-x}\text{N}$  bulk systems. Tight-binding results are given by the blue open circles, while literature HSE06-DFT (J. Chem. Phys. 134, 084703 (2011)) results are shown by the black stars. Literature experimental data are indicated by the green stars (J. Appl. Phys. 93, 4340 (2003)) and the red squares (Phys. Rev. B 75, 205204 (2007); Phys. Status Solidi B 249, 485 (2012)), respectively.

we find that in AlInN the band gap bowing parameter is strongly composition dependent. The alloy InGaN represents an intermediate situation. For the binary materials, the band offsets have been taken from literature HSE06-DFT data. The composition dependence of the band offsets has been determined from our tight-binding supercell calculations.

### $k \cdot p$ parameters for zincblende III-N materials

In addition to tight-binding parameters, we have also extracted 8-band and 14-band  $k \cdot p$  parameters for zincblende InN, GaN and AlN. These parameters have been derived by fitting the  $k \cdot p$  band structure at  $\mathbf{k}=\mathbf{0}$  to the tight-binding band structure. Although we have derived 14-band  $k \cdot p$  parameters here, we note that the 8-band model should generally be sufficient for studying III-N alloys, due to the large energy separation between the conduction band minimum and the next conduction bands at  $\Gamma$ .

### ***Piezoelectric coefficients for III-V materials***

In addition to the mechanical and band structure data, also piezoelectric coefficients have been extracted via HSE06-DFT-based Berry-Phase calculations. For zinc blende III-V materials, both first- and second-order coefficients have been determined. To understand general trends in the piezoelectric coefficients for the different materials, we have developed here simpler models to explain these trends. In addition to zinc blende III-V materials, piezoelectric coefficients, including the spontaneous polarization, for wurtzite III-N materials have been determined. These parameters have also served as input for the modelling of nitride-based heterostructures and in particular for our in-house developed local polarization theory.

### **2.3 Analysis of Charge Transport Models**

Our work on charge transport models builds on and takes advantage of the DEEPEN parameter database and its description of the electronic structure of alternative channel materials for nanoscale transistors, particularly alloys of the III-V materials gallium indium arsenide. To determine the current-voltage characteristics for advanced nanoelectronic devices requires simulators that can couple a quantum mechanical description of the electronic structure of materials to a quantum mechanical description of the charge transport. Significant collective consortium effort was dedicated to this activity as it is central to the overall success of DEEPEN. The quantum transport programs OMEN and TiMeS were used as part of this activity and interfaces to the quantum electronic structure codes VASP, Quantum ESPRESSO and OpenMX were developed. An interface between OMEN and Synopsys' commercial drift-diffusion simulator Sentaurus Device was also implemented. The coupling between the electronic structure and quantum transport simulators was demonstrated for a variety of applications related to the development of novel channel materials for nanoelectronic transistors. The interfaces that were developed to allow for the multi-scale coupling of the various software tools were used as the basis for setting up the multi-scale simulation framework presented in Section 2.4 and relying on the open source middleware Unicore for the design of simulation workflows.

Several tight-coupling interfaces were designed to allow for a common implementation pathway to be defined in the multiscale simulation environment. Two electronic structure methods implementing a density functional theory (DFT) and providing a quantum description of the electrons in a device were used: a plane wave or 'delocalized' description and an orbital or 'localized' description. Many common community electronic structure programs are based on a 'delocalized' description as the convergence of such calculations can be systematically controlled, whereas 'localized' descriptions can be computationally less expensive, but somewhat trickier to converge. However, quantum transport simulators require a 'localized' electronic structure calculation. Hence for using common community software, a localization step is required.

Additionally to the 'delocalized' electronic structure coupling to the transport simulators shown in Fig. 2.4, an interface to the transport simulator TiMeS was written to enable a self-consistent loop between the open source electronic structure program OpenMX, which directly provides a 'localized' description of the electronic structure. Similarly, OMEN was used with a tight-binding or 'localized' description of the electronic structure to describe band-to-band tunnelling in indium gallium arsenide (InGaAs) channels with differing alloy contents. We investigated whether an explicit treatment of alloying is required or whether an effective treatment of alloying, using what is known as the virtual crystal approximation (VCA) is sufficient to treat the effect of parasitic tunnelling in short channel III-V transistors (Fig. 2.5). Direct comparison between the explicit alloy models and the VCA approach reveals that for practical device simulation, the VCA approach is sufficient to describe band-to-band tunnelling (BTBT) in short channel III-V transistor channels (Fig. 2.6).

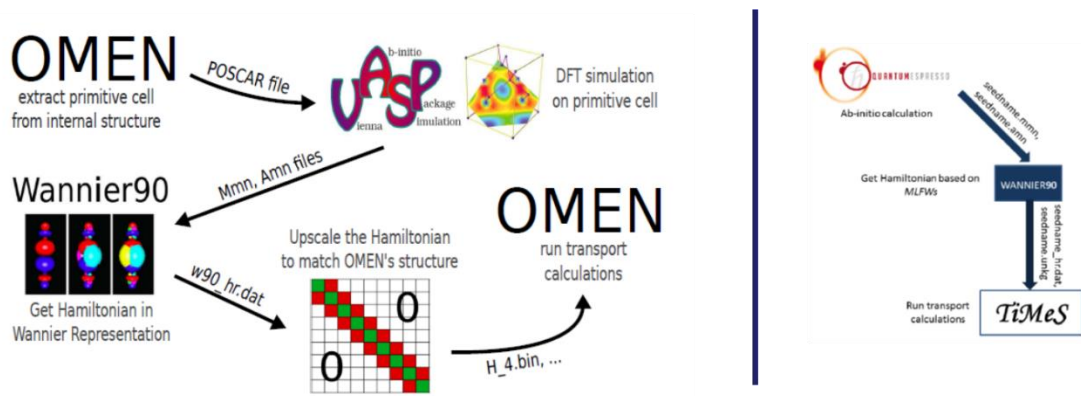

**Figure 2.4:** Coupling of the quantum transport program to ‘delocalized’ electronic structure program. The diagram on the left shows the electronic structure code VASP coupled to Wannier90 (which performs the localization step) to the quantum transport code OMEN. Similarly in the right of the figure, the electronic structure program Quantum ESPRESSO is coupled to the transport simulator TiMeS through Wannier90. The interfaces developed here are then used to allow a ‘plug and play’ approach with different simulation tools performing the same function that can be interchanged seamlessly.

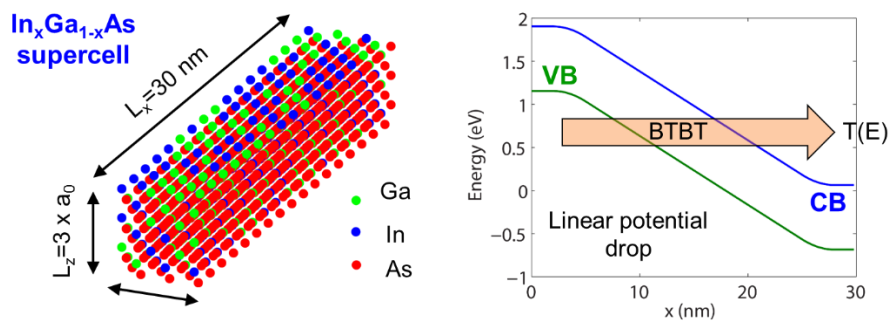

**Figure 2.5:** (Left) Schematic view of the random alloy samples considered in the study. The indium concentration is set to 53%, that of Ga to 47% on the group III sub-lattice. (Right) The electrostatic potential profile used to evaluate the band-to-band tunnelling probability as different voltages are applied across the channel region.

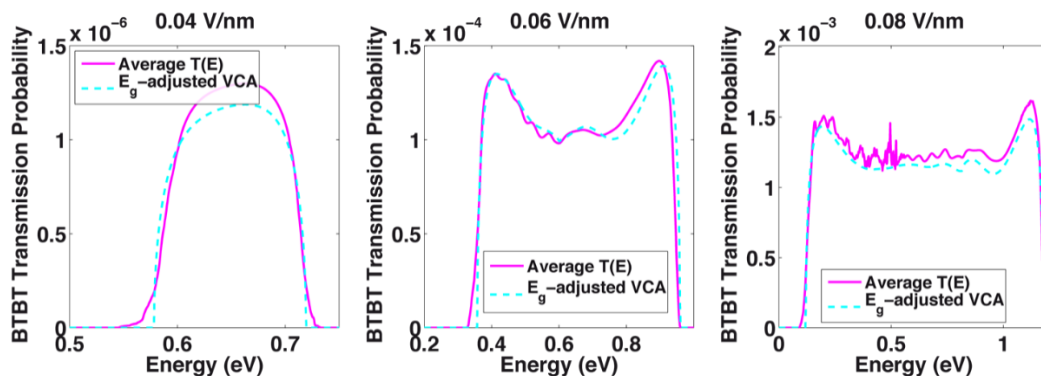

**Figure 2.6:** Comparison between BTBT probability averaged over 50 random alloy samples and obtained by slightly adapting the indium concentration in the improved VCA model at three different values of applied voltage yielding different channel electric fields (given at the top of each plot).

In addition to coupling to explicit quantum mechanical electronic structure descriptions of transistor channels, an interface for the drift-diffusion device simulator Sentaurus Device

from Synopsys was developed to allow coupling via shared memory blocks to the effective mass version of OMEN. As the objective is the computational efficiency of the resulting multi-scale simulator, coupling of the effective mass simulator to the drift-diffusion tool was the best option in terms of turnaround time for the simulations – a key requirement for industrial applications. In addition, the effective mass approximation can still be seen as a single s-orbital tight-binding model demonstrating that the approach being developed can be extended to more detailed descriptions of a transistor’s electronic structure.

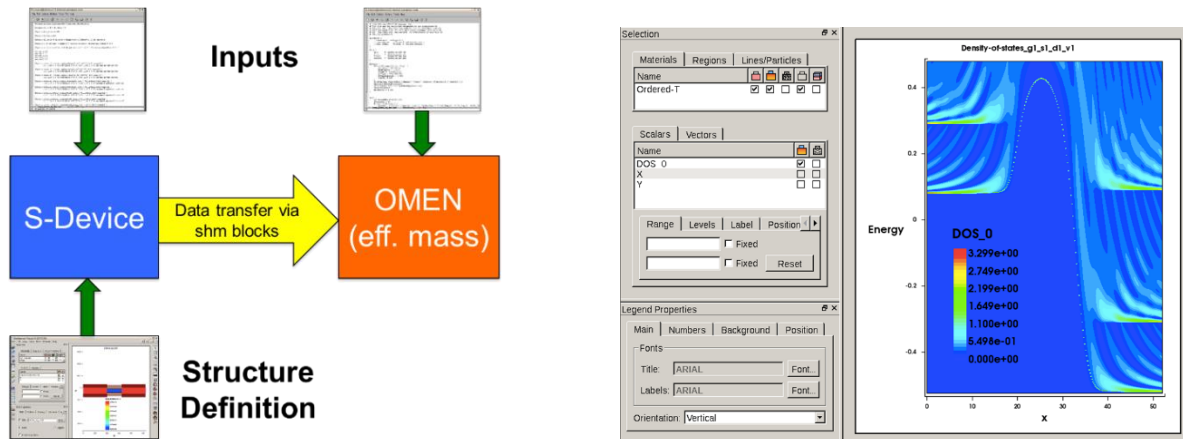

**Figure 2.7:** (Left) Flow chart illustrating the coupling between Sentaurus Device and OMEN Effective Mass software packages. Four main tasks have been identified to enable the coupling between the simulators: (1) preparation of the input files for both codes, (2) definition of the device structure to be simulated (in S-Device), (3) data transfer between the two softwares, and (4) (Right) production of output results; shown is an example of the density-of-states from source to drain with application of a voltage bias.

The exchange of data between Sentaurus Device and OMEN Effective Mass occurs during the initialization phase of the device simulation and subsequent outputs are generated by OMEN Effective Mass in a format that can be read back into the Synopsys tool suite, S-Visual in the present case (Fig. 2.7). Quantities such as the electrostatic potential, the spectral and spatial current distribution, the contact bandstructure, the gate leakage current, or the ballisticity of the considered logic switch can also be visualized using the S-Visual graphical display.

## 2.4 Multiscale Simulation Environment

### Introduction

The core effort in DEEPEN was dedicated to the development of the multiscale simulation environment. This Open Source Interface (OSI) has been implemented based on the UNICORE framework and allows the execution of simulation workflows involving different modelling tools, operating at different length scales and based on different physical models. The aim has been to develop an integrated multiscale simulation capability for predictive design of innovative materials and nanostructures for applications in photonic and electronic devices. The final version of the multiscale OSI has been released under the GNU Lesser General Public License (GNU LGPL). This guarantees that the core of the multiscale environment as well as all its Application Programming Interfaces (APIs) can be distributed and even modified freely. The goal of DEEPEN is in fact to facilitate further development of the OSI by providing future users all the tools to extend and improve the environment.

### CDF implementation

As a first step of the development of the OSI, a common data format (CDF), to be used in data exchanges between simulation tools, has been defined and implemented, based on relevant I/O parameters, as provided from the DEEPEN parameter database and the requirements of the charge transport models. The CDF has been defined based on the standard open source Hierarchical Data Format (HDF), which is widely used for scientific data storage. A small (Lite) API has been developed to read/write data on the CDF using the façade pattern. This API is used by the translators that convert proprietary formats into the CDF format. As part of our OSI development, we implemented in our API a subset of all the datatypes natively supported by the format: String, Float, Integer and Array.

HDF can in general be browsed like a UNIX file system, so we chose to provide a hierarchical representation of CDF data, similar to a path to organize data to be written in a file. This characteristic is well suited also to implement a small key-value database using a combination of groups and datasets. An HDF-based Database has been thus implemented and finalized with the material parameters obtained in DEEPEN (see ref. [15]), including the *ab-initio* computed band structure, structural, mechanical and piezoelectric parameters for both unstrained and strained III-V binaries and ternary alloys (see Fig.2.8). This set of calculated material parameters has been thus integrated into the OSI, providing in this way a multiscale parametric linking between *ab-initio* atomistic simulation tools and drift-diffusion simulators (Sentaurus Device, TiberCAD).

### UNICORE system

The OSI developed in DEEPEN has been implemented in the framework of the UNICORE system. UNICORE is a general-purpose software suite with a client-server architecture, providing access to compute resources as well as data resources. It follows the latest standards from the Grid and Web services world and offers a rich set of features to its users. All UNICORE software is available as Open Source under BSD license from the UNICORE website<sup>20</sup>. In order to implement the DEEPEN OSI with UNICORE, two kinds of application software objects (GridBeans) for UNICORE have been developed for each tool involved in the workflows describing the multiscale simulation protocols. The first object, in the following called *Application Interface*, is needed to handle access to the tool in the UNICORE-based OSI. The second, in the following called *CDF Translator*, is dedicated to the translation from the tool native file format to the CDF and vice versa. In this way, output provided from each tool is made available to other tools included in the workflow. If a new tool has to be included in the workflow, there is no need to know the details of the proprietary format of all the other tools. One only needs to implement in UNICORE the CDF Translators for its tool format. Documentation and tutorials to help implementation of CDF as well as GridBean Apps are available following completion of the Project. In this way, interoperability between simulation tools is assured even in future applications which will extend the Multiscale environment developed in DEEPEN.



Figure 2.8: Example of Database structure

<sup>20</sup> [www.unicore.eu](http://www.unicore.eu)

## Overview of DEEPEN OSI

Fig. 2.9 presents a view of the DEEPEN OSI, showing the overall schema of the OS multiscale environment implemented in the project. The simulation tools, such as OMEN, Wannier90, Quantum ESPRESSO, etc. are given access to the OSI through the Gridbean APIs and their respective translators available inside the Rich Client of the UNICORE environment. In this way, there is no need to modify the code of the single simulation tools to implement the APIs. In case of a new version of a tool, only the Gridbean code must be updated, which may be performed even by the manager of the OSI platform, based on the tool public documentation. Similarly, data in the OSI are exchanged through the CDF translators, so that no information on the tool proprietary format is needed to link two different tools. In case of modification of the format of a tool, or when a new tool is included in the OSI, only the CDF translator for that tool must be updated, by the owner of the tool or, if format specifications are public, even by the manager of the OSI. In addition, since CDF is built on the OS HDF library, all the features of HDF APIs are available for I/O operations on data files and for queries on the material database. The workflows linking the simulation tools are implemented on the client/server UNICORE system. Here, on the client side, the graphical editor allows to build each workflow in an interactive way, while the Workflow services deal with the workflow and jobs execution. On the server side, the submitted jobs are scheduled for execution through a queue manager called SGE that handles the requests and the hardware resources.

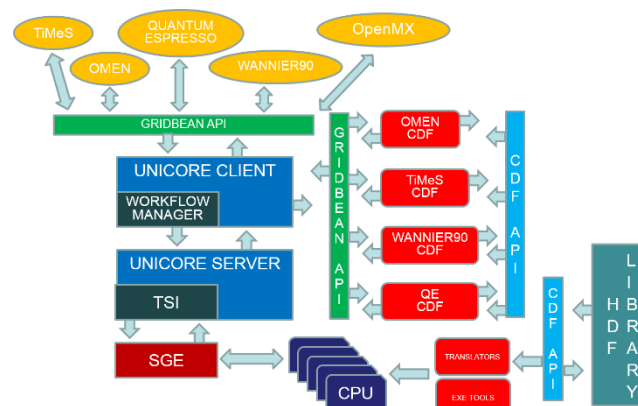

Figure 2.9: DEEPEN Environment

Two example workflows have been implemented and are available online. They show the capabilities of the system, and the flexibility of the format chosen for CDF. Both the workflows describe the linking between a DFT tool and a quantum transport code. The first workflow implements the case of a linking between the DFT tool Quantum ESPRESSO (QE) and the quantum transport code OMEN. The second implements a linking between the DFT software tool OpenMX and the tight-binding based tool for quantum transport TiMeS, developed in Tyndall.

All the documentation of the OSI is available online at the [www.tibercad.org](http://www.tibercad.org) website [16] together with the Open Source code of all the APIs developed in the project. Based on the developed OSI core and using the same methodology shown in the examples, it is possible to link alternative DFT codes to several other NEGF codes, in addition to OMEN and TiMeS. What is needed is essentially to implement the CDF translator API and the tool specific Gridbean, unless the new tool to be linked is not already supported in the environment. This shows clearly the OSI system flexibility and its potential to increase interoperability between simulation tools.



## 2.5 Application to Advanced CMOS Devices

To test and inform the DEEPEN Open Source environment, specially designed demonstrator devices were developed to represent typical advanced transistors with InGaAs-based channel materials. Because industrial TCAD applications run based on the QDD (Quantum Drift-Diffusion) model frame the development and release of corresponding TCAD simulation setups that contain project results like material and model parameters and links to the Open Source Interface are mandatory for the exploitation of the results of the DEEPEN project. Specially designed software and formats developed for the Open Source Interface are used to extract and implement the material parameters for QDD simulation, including band edges and gaps, deformation potentials, and effective masses. Figure 2.10 shows the structure and doping in one of the demonstrator devices (a 3D-FinFET with an InGaAs channel).

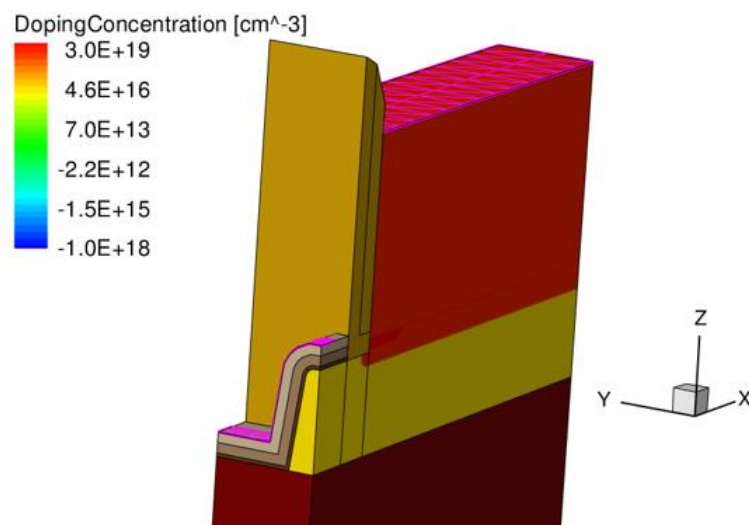

**Figure 2.10:** Structure and doping of one of the demonstrator devices (a 3D-FinFET with an InGaAs channel).

The development of the TCAD simulation setups included testing, calibration, model development, implementation of material parameters, and validation against reference simulations and measurements. The setups including model developments and parameters from the DEEPEN project will be released with Synopsys' standard release N-2017.09. The following simulation setups will go into the release:

1. 2D-FDSOI-FET including calibrated ballistic mobility model. The setup contains typical features of state of the art InGaAs-based FDSOI-FETs.
2. 3D-FinFET including calibrated ballistic mobility model. The setup contains typical features of state of the art InGaAs-based FinFETs (see Fig. 2.10).
3. 2D-DG-FET including calibrated ballistic mobility model. This setup is used for comparison with "high-level" reference tools.

These setups are used in the project for performance investigations for uprising new technology concepts and material configurations. Those investigations are one of the main application areas of TCAD. Model and material parameters are of utmost importance for

that. For these investigations four different devices are studied, two Silicon channel devices (unstrained and strained channel) and two InGaAs channel devices (with silicon-like doping/configuration and representing state of the art technology). The different device types are described in Table 2.1. The performance investigations are done using typical targets like  $I_{on}/I_{off}$  ratio, sub threshold slope, and drain-induced barrier lowering (DIBL). Figure 2.11 shows the  $I_{off}(I_{on})$ -plot for the different types of devices. Because of these performance investigations the strained silicon FinFET seems still to be the best option under the currently available silicon and III-V technology and device concepts. Probably only a major improvement of the III-V technology with respect to leakage currents for very short channels, doping concentration activation of source, drain, and extension, and concentration of traps and defects can provide a breakthrough for InGaAs compared to strained silicon.

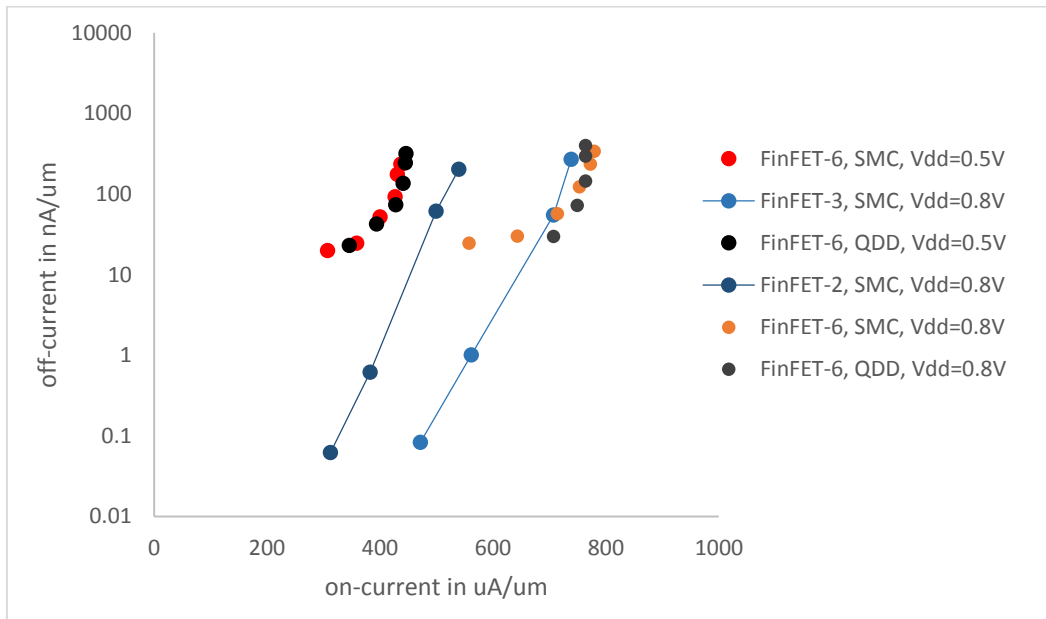
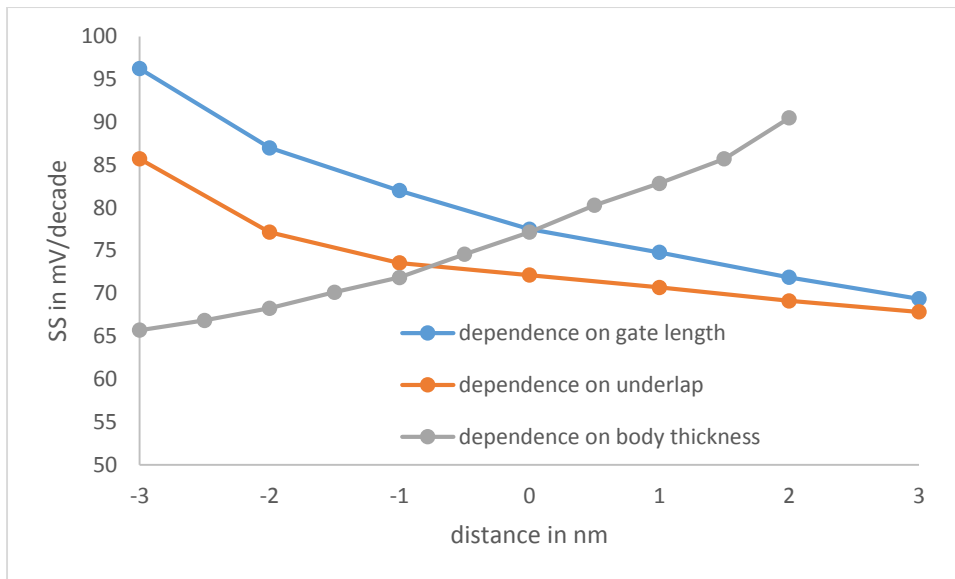

**Figure 2.11:**  $I_{off}(I_{on})$ -plot for the different types of devices.

Special focus is set on the leakage current and especially the off-current of the transistors, because it has been found that source-to-drain tunnelling significantly deteriorates the sub-threshold slope (SS) and DIBL in III-V transistors with gate lengths shorter than 15 nm. Therefore, in addition to the TCAD-based performance investigations a first-principle study of source-drain tunneling in nanoscale transistors with novel channel materials was performed, using a tight-binding full-band approach (OMEN). Figure 2.12 shows the influence of process and structure parameters on the subthreshold slope of the transistor.

Device	Channel material	Strain	Doping
FinFET-2	Silicon	Unstrained	Typical Silicon doping
FinFET-3	Silicon	Strained (1.5GPa)	Typical Silicon doping
FinFET-6	InGaAs	Unstrained	State of the art InGaAs doping

**Table 2.1:** Devices under investigation



**Figure 2.12:** The influence of process and structure parameters on the subthreshold slope (SS) of a DG (Double Gate) thin film device.

To demonstrate the coupling between NEGF and Sentaurus Device the influence of source-to-drain tunneling on the transistor performance is calculated. The demonstration shows that the coupling and the NEGF code itself are so fast and efficient that simulations comparable to normal TCAD simulations can be performed for nano-scale devices. Figure 2.13 shows the electron density distribution in such a nanowire device. Table 2.2 contains data regarding the simulation performance (simulation speed).

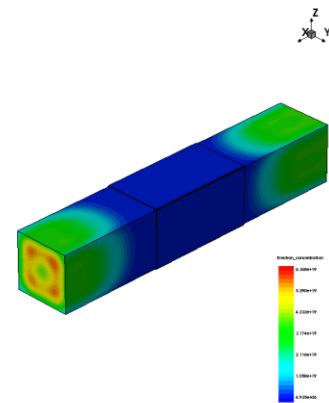

Gate length	Wallclock time
10nm	3004s
12.5nm	3196s
15nm	3356s

**Table 2.2:** Simulation performance (Intel Xeon, 2.6GHz, 20 cores, 16 cores used,  $I_d$ - $V_g$  with 8 voltage bias points)

**Figure 2.13:** Electron density distribution in a nanowire device.

## 2.6 Application and Validation for III-N LED Devices

Nitride light emitting diodes (LEDs) have undergone a tremendous progress in the last decades both in terms of efficiency and reliability, making possible the solid-state lighting revolution that we are living today. From the beginning, it was recognised by the scientific community that III-N semiconductors had unique properties when compared to classical III-V semiconductors, whose origin had to be traced all the way to their microscopic structure. A key objective of DEEPEN was to develop and validate multiscale models capable of describing realistic nitride LEDs, taking such microscopic influences into account. This work covers both planar devices, currently dominating the market, and nanowire (NW) LEDs. We summarize here the modelling and experimental efforts on III-N LEDs over the project duration, as well as the main achievements.

### Analysis of optical and transport properties of axial (In,Ga)N/GaN nanowire LEDs

The first objective in III-N simulation was to understand and predict the electronic and optical properties of (In,Ga)N/GaN NW LEDs, based on detailed three-dimensional (3D) calculations of strain and electronic structure. Such devices have received increasing interest in the research community in the last decade. One of the main advantages of this approach is the elastic relaxation of the strain induced by lattice mismatch at the free NW sidewalls, thus enabling the growth of high quality (In,Ga)N/GaN heterostructures along the NW axis with In content higher than in conventional planar LEDs. Because of this relaxation, the strain distribution inside the active region of LEDs based on NWs significantly differs from the one present in planar devices. Thus, these nanostructures provide a particularly challenging test bed for multiscale simulations. A highlight of the work in DEEPEN is a combined experimental and theoretical study of the consequences of the three-dimensional strain variation for the electroluminescence (EL).

Figure 2.14(a) presents an illustrative sketch of the active region in a single NW; the entire device consists of about one million NWs contacted in parallel. Figure 2.14(b) shows experimentally measured EL spectra for three representative injected currents. The spectra are characterized by a rather broad emission band consisting of two main contributions, which exhibit a blue shift with increasing injected current. The relative intensities of the two transitions, labelled “Peak1” and “Peak2”, evolve in a peculiar way. Spectrally and spatially resolved EL maps demonstrate that the two bands are emitted by the majority of NWs in the ensemble.

In order to elucidate the physical origin of this double-peak structure, we calculated strain, electric field, and charge carrier distributions inside the active region of both planar LEDs and NW-LEDs and simulated their EL spectra. We found that the physical origin of the double peak structure is a stronger quantum-confined Stark effect in the first and last quantum well (QW) of the heterostructure. This phenomenon results from the nitrogen crystal polarity of these structures and is observed as well in the simulated EL spectra of planar N-polar but not of planar Ga-polar LEDs. The simulations show also that the peculiar evolution of the relative EL peak intensities with injected current, observed only in the case of the NW-LED, is caused by the strain relaxation characteristic for NWs. Therefore, we directly identify consequences of the NW morphology on the emission properties of LEDs. Furthermore, we provide important insights on the recombination mechanisms of N-polar LEDs in general.

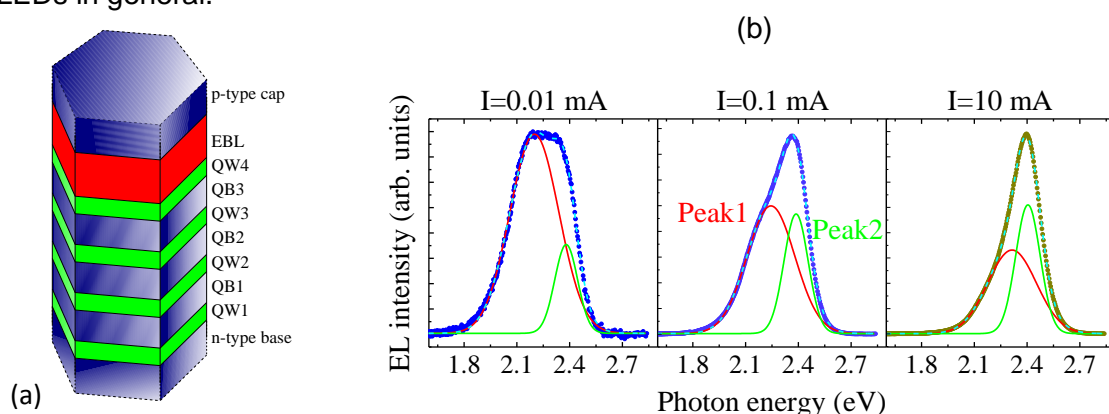

**Figure 2.14:** (a) Illustrative sketch of the active region of a NW-LED. It consists of four (In,Ga)N quantum wells (QWs), separated by three GaN quantum barriers (QBs). The last quantum well (labelled QW4) is immediately followed by a Mg-doped (Al,Ga)N electron blocking layer (EBL). Note that the different dimensions are not to scale. (b) Exemplary experimental EL spectra (data points) of the NW-LED and fits obtained by means of two Gaussians (solid lines). The dashed lines depict the cumulative fits. The injected currents are indicated above the spectra.

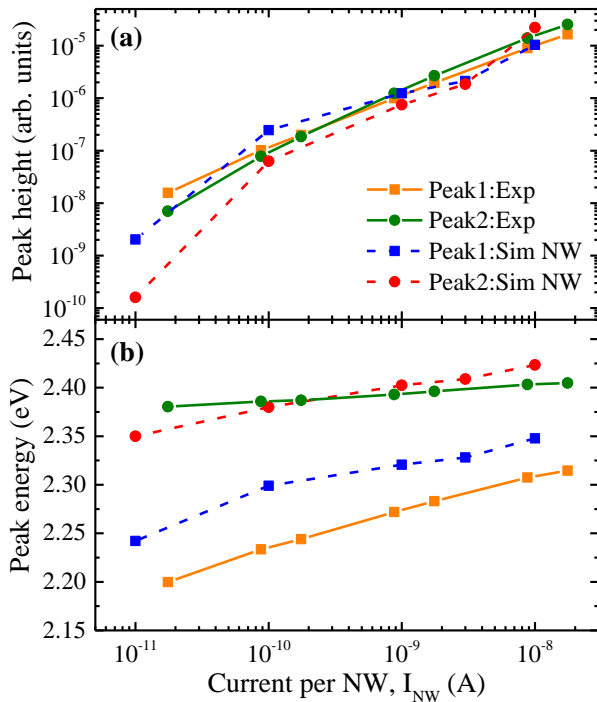

**Figure 2.15:** Comparison between simulated and measured optoelectronic properties of the NW-LEDs. (a) EL intensity and (b) energy position of the two main peaks plotted vs. the average current per NW.

Figure 2.15 summarizes the intensity and energy position of the two main transitions as a function of injected current. The agreement between simulated and measured values is quantitatively rather good over almost the entire current range. This assessment holds in particular in view of the following limitations in the theoretical description. Firstly, the actual structure of the NWs may be more complex than that sketched in Fig. 2.14(a) and considered in our simulations. Furthermore, physical phenomena that are known to be important for the luminescence of such NWs, in particular indium segregation and the

formation of crystal defects, are not included in the simulations. Therefore, we can conclude that the modelling tools and the schema for multiscale parametric linking developed in the project are well suited to describe the main aspects in the physics of NW-LEDs.

### **Impact of barrier alloy fluctuations on vertical transport in InGaN/(AlGa)N MQWs**

The second objective in III-N simulation was to analyze and understand the impact of (random) alloy fluctuations and barrier width on the vertical transport properties of InGaN multi quantum well (MQW) systems. To achieve this goal, in a first step, parameters derived and atomistic models developed as part of the DEEPEN parameter database have been used to calculate the electronic structure of the active region, namely the InGaN QWs. Applying the atomistic tight-binding-based framework developed for the database allowed us to study the impact of random alloy fluctuations on the electronic and optical properties of these systems. Equipped with this knowledge, in a following step, the tight-binding electronic structure code has been connected to the non-equilibrium Green's function transport (NEGF) code OMEN, developed by the project partner ETHZ. Here, the tight-binding code receives also input of electrostatic built-in fields from 1-D drift-diffusion calculations performed using TiberCAD. Overall this established framework allows us now to address vertical transport properties of InGaN/(Al,Ga)N QWs on an atomistic level.

For instance our tight-binding calculations revealed that especially holes are localized due to random compositional and well-width fluctuations in (In,Ga)N. The calculations demonstrate that localization of holes not only occurs for the ground state but also for the excited states. An example of this situation is given in Figure 2.16, showing the electron and hole ground state charge densities in a c-plane  $\text{In}_{0.25}\text{Ga}_{0.75}\text{N}/\text{GaN}$  QW. The spatial

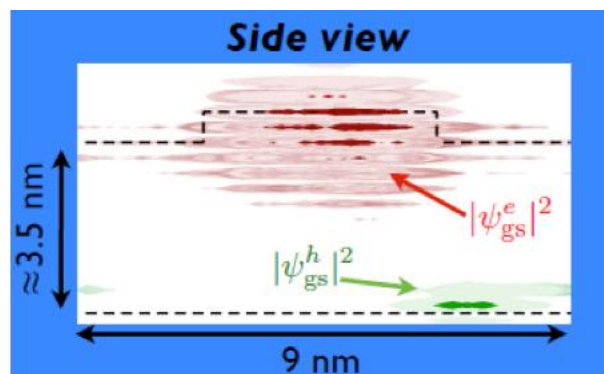
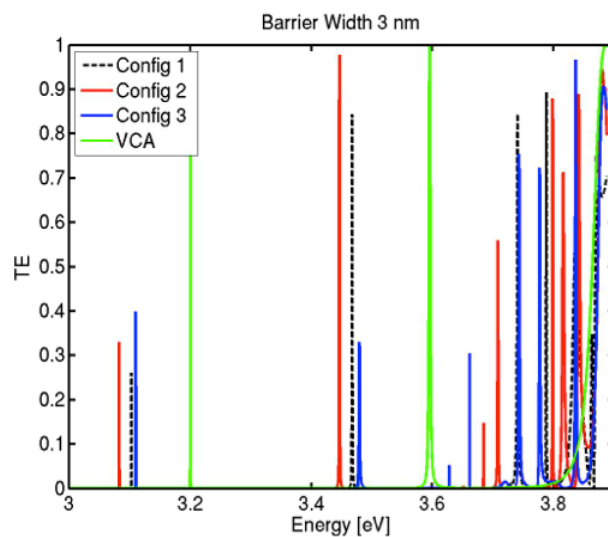

**Figure 2.16:** Electron (red) and hole (green) ground state charge densities in a c-plane  $\text{In}_{0.25}\text{Ga}_{0.75}\text{N}/\text{GaN}$  QW. The dashed lines indicate the QW interfaces, including a well width fluctuation.

separation of the carriers along the growth direction results from the strong electrostatic built-in field present in these structures. Thus, significant localization is predicted also at elevated temperatures and high concentration of charge carriers, important for transport properties. In addition, we predict the recombination of spatially separated electrons and holes, which was experimentally verified by time-resolved photoluminescence measurements.

Using the multi-dimensional theoretical models developed here (Fig. 2.16), we studied the impact of random alloy fluctuations and electron-phonon scattering on the vertical and lateral transport properties in InGaN/GaN MQWs. Special attention was paid to uni-polar (electron) transport properties. The theory was complemented by experimental data provided by OSRAM. The active region of these systems has been analyzed by NEGF calculations. With this model we were able to show that electron-phonon scattering plays a central role in populating the well states. Secondly we found that when including random alloy fluctuations in the calculations the transport properties were significantly affected compared to a virtual crystal description. As an example, Fig. 2.17 shows the transmission

(TE) spectrum through an In<sub>0.27</sub>Ga<sub>0.73</sub>N/GaN MQW with a barrier thickness of 3 nm. Configs. 1, 2 and 3 in Fig. 2.17 denote the three different microscopic configurations considered. When comparing the results from the microscopic configurations (red, black dashed and blue lines) with the virtual crystal approximation data (VCA, green), we find that all three microscopic configurations give TE peaks below 3.2 eV, where the lowest energy TE peak in the virtual crystal approximation appears. This can be interpreted as showing that the microscopic configurations open “new channels” for the electron transport. However, we find here that these effects are strongly affected by the barrier width between the QWs.



**Figure 2.17:** Transmission (TE) spectrum of an In<sub>0.27</sub>Ga<sub>0.73</sub>N/GaN MQW with 3 nm barrier thickness. The three different configurations are denoted by Config 1, Config 2 and Config 3, respectively. The virtual crystal result is denoted by VCA.

### **Lateral transport**

To implement a multi-dimensional LED model it is essential to describe the in-plane transport of the carriers once they are injected in the (In,Ga)N quantum wells (QWs), including the impact of lateral quantum well thickness and alloy fluctuations.

Presently, the nitride community agrees on the absence of carrier diffusion in (In,Ga)N at low temperatures due to localization effects. However, a much wider spread in reported literature values is found for higher temperatures (0-3 cm<sup>2</sup>s<sup>-1</sup>), depending on temperature, excitation condition and the measurement technique employed. This issue has been tackled in DEEPEN by combining different complementary experimental approaches as well as theoretical modeling.

On the one hand, temperature-dependent time-resolved photoluminescence (TRPL) measurements were conducted with planar blue and green (In,Ga)N/GaN(0001) single QW samples (see Fig. 2.18). Typical curves show an almost constant luminescence intensity up to tens of nanoseconds (depending on temperature), followed by a power law decay at long delays independent of temperature. Analysis of the effective and radiative decay times as a

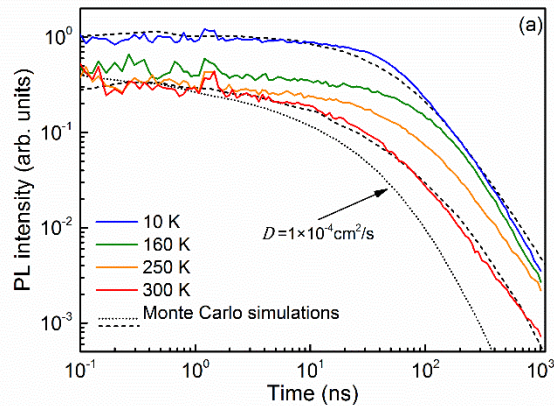
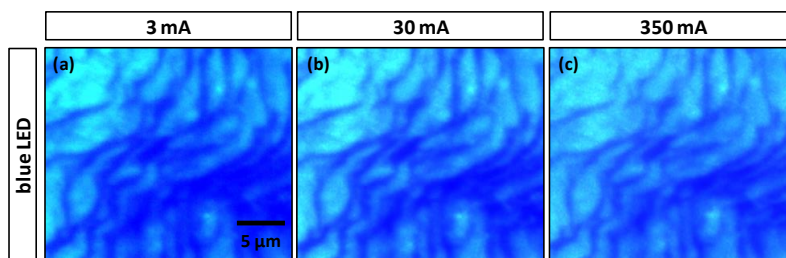

**Figure 2.18:** Exemplary temperature-dependent time-resolved PL transients of the blue SQW. The double logarithmic representation reveals decay dynamics following a power law at long delays. The dashed lines indicate the results from the Monte Carlo simulation. The gray line with  $D=1\times 10^{-4}$  cm<sup>2</sup>/s, when compared to the  $D=1\times 10^{-5}$  cm<sup>2</sup>/s dashed line at 300K, illustrates the sensitivity of the Monte Carlo algorithm.

function of temperature reveal that above >100 K recombination occurs between spatially separated, mobile electrons and localized holes in a two-dimensional potential.

These PL transients were further analyzed by means of a novel Monte Carlo algorithm developed for the project, which is not limited by spatial resolution. To obtain a good fit of the experimental curves the diffusion coefficient of the holes had to be set to zero. For the electrons we extracted a diffusion coefficient of  $D=1\times 10^{-5}$  cm<sup>2</sup>/s (300K) and  $D=0$  cm<sup>2</sup>/s (10K), (cf. dashed lines in Fig. 2.18). Consequently, the diffusion of charge carriers seems to be inhibited at low excitation densities and low temperatures by the localization. As no unique PL lifetime  $\tau$  exists, a diffusion length cannot be defined, either. However, if we assume that the charge carriers are able to diffuse for times up to 1  $\mu$ s (maximum time range in the measurement [cf. Fig. 2.18]), we obtain a value of  $L_D\approx 32$  nm at 300 K (with  $D=1\times 10^{-5}$  cm<sup>2</sup>/s). These results are consistent with cathodoluminescence experiments conducted on bulk GaN and InGaN layers, in which the diffusion length was estimated to be below the experimental resolution of 50nm.

To investigate whether localization effects persist at the higher carrier densities typical of device operation, blue and green top-emitting LEDs with polished surface were fabricated. Then  $\mu$ -PL and  $\mu$ -EL maps (for different applied currents) were measured with a microscope. The  $\mu$ -EL maps are very similar over a large current range (Fig. 2.19), indicating that an enhanced density of charge carriers does not change the behavior of the EL significantly. Pearson correlation coefficients between peak photon energy and intensity of  $-0.7\leq \rho\leq 0.2$  (mostly anti-correlation) and  $0\leq \rho\leq 0.8$  (correlation) were obtained, respectively, for blue and green LEDs. In the latter case, defects and dislocations may be playing a significant role.



**Figure 2.19:** (a)  $\mu$ -EL photographs of a blue LED. The current varies over two orders of magnitude ranging from (a) 3 mA to (b) 30 mA and (c) 350 mA. The color brightness represents the EL intensity.

On the theory front, carrier localization was investigated with atomistic tight-binding models developed for the DEEPEN parameter database.  $\text{In}_x\text{Ga}_{1-x}\text{N}/\text{GaN}$  QWs with average indium contents of 10%, 15% and 25% were simulated, to determine the ground and excited state energies and wave functions for both electrons and holes. A random distribution of indium atoms was assumed and the results were averaged over many microscopic configurations.

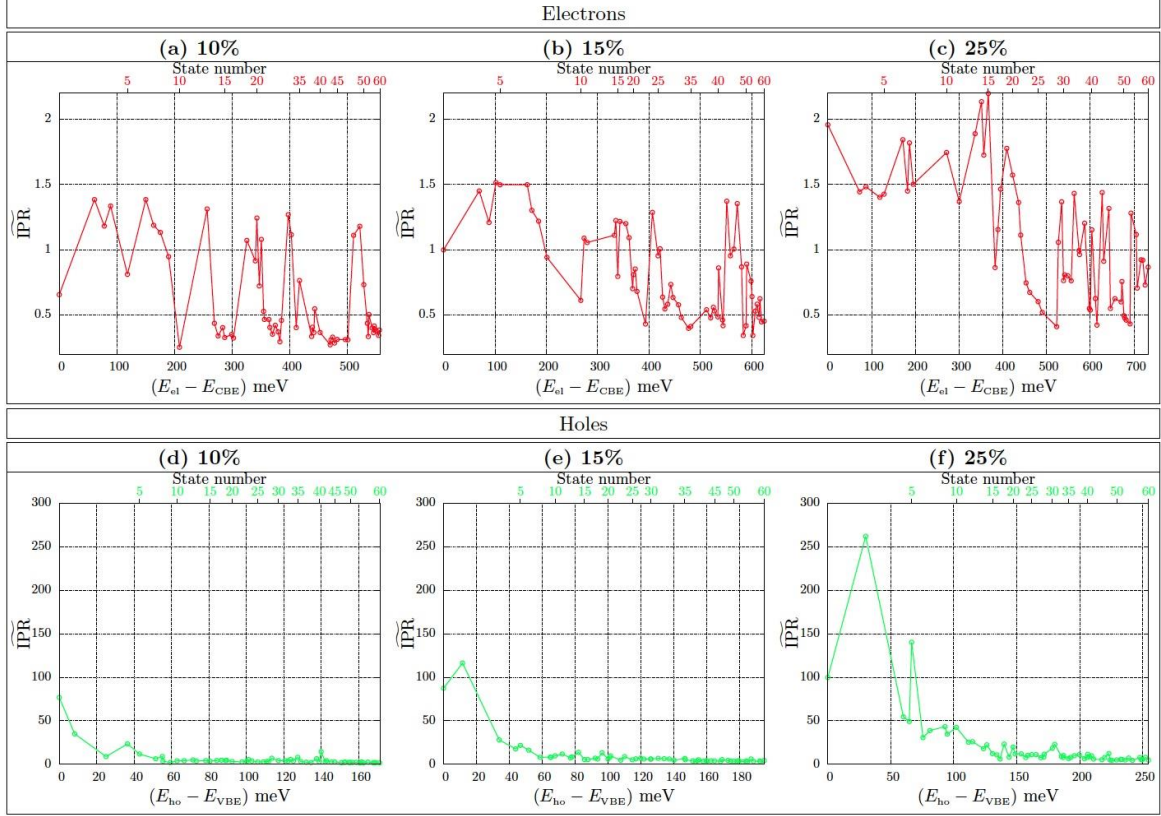

**Figure 2.20:** Normalized electron (top row) and hole (bottom row) inverse participation ratios ( $\tilde{\text{IPR}}$ ) plotted against the state energy as measured from the conduction or valence band edge. The results are given for particular representative configurations with indium contents of 10%, 15% and 25% (see text for selection criteria). The IPRs are normalized with respect to the IPR of the most localized 10% electron ground state.

To provide an objective measure of localization, the metric of the inverse participation ratio (IPR) was chosen. The IPR can take values continuously between 1 (complete localization) and  $N^{-1}$  (completely delocalized state,  $N$  being the number of lattice sites). In the following discussion the IPR values are normalized ( $\tilde{\text{IPR}}$ ) to that of the electron ground state with the largest IPR value ( $1.529 \times 10^{-4}$ ) in the 10% indium case.

Simulation results confirm that hole ground states are, in general, far more localized than the electron ground states (between 5 and 350 times, see Fig. 2.20). Furthermore, hole ground state energies are not that influenced by the built-in field but do vary significantly between different configurations, reflecting their sensitivity to the microscopic structure. Interestingly, configuration interaction calculations indicate that the electron and hole wave function separation due to the presence of the built-in potential and the localization effects is much stronger than the attractive electron/hole Coulomb interaction. This provides key information for experiments performed at low temperatures and low carrier densities.

To gain insight into the optical and transport properties of polar (In,Ga)N/GaN QWs at room temperature and at higher carrier densities, electron and hole excited states were also analyzed. Figure 2.20 shows the  $\tilde{\text{IPR}}$  values for the first 60 electron and hole states as a function of the energy, measured with respect to the corresponding ground state energy for a representative configuration. In general the  $\tilde{\text{IPR}}$  values for the first few electron and hole excited states increase with increasing indium content. We attribute this effect to the increasing piezoelectric built-in field with increasing indium content. Thus, one can expect that the energy depth into the valence band to which there are still localized hole states (sometimes called tail states due to their impact on the density of states) increases with increasing indium content. This is consistent with the experimentally observed increase of



the PL width, Stokes shift, and absorption edge broadening with indium content. Combining a conservative estimate for the energy range of localized states inferred from our ground state data and the insights from the excited state studies, we estimate that already in the case of 10% indium, the total spread of localized states amounts to  $\approx 100$  meV. Thus, we expect an energy range of at least 100 meV over which there will be a significant density of localized valence states in polar (In,Ga)N/GaN QWs with indium contents at or above 10%. This should measurably affect the optical properties of these systems at elevated temperatures.

### **Development and validation of a quasi 3D model for III-N LEDs**

The final objective in III-N LED simulation was to study the carrier transport properties of InGaN-based multi-quantum wells (MQWs) in the framework of multi-dimensional theoretical models, addressing vertical and lateral transport properties. For the validation of the models, OSRAM fabricated and characterized uni-polar test structures with different numbers of QWs, barrier thicknesses and indium contents. Experiments (see Fig. 2.21) reveal voltages attributed to electron transport, which are significantly smaller than those expected from 1D drift-diffusion (DD) calculations. This points to the importance of accounting for the atomistic nature of the materials and inhomogeneities at the smallest scales.

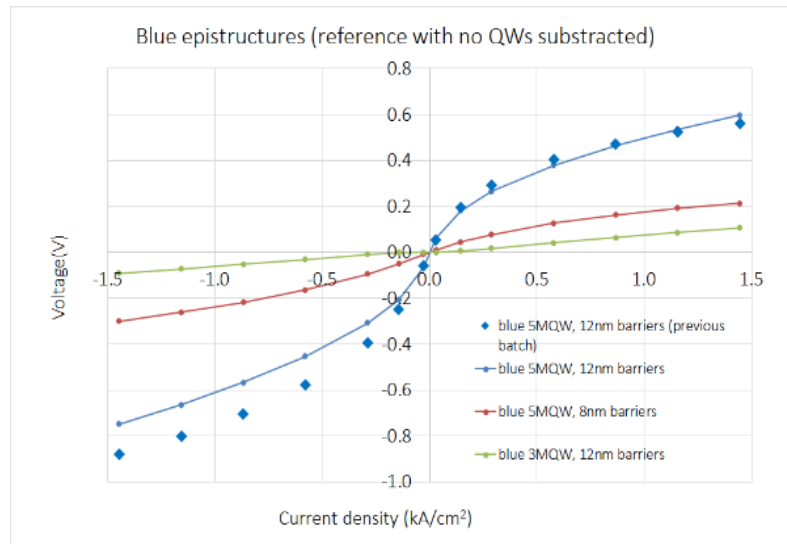

**Figure 2.21:** Experimental results for MQW samples with indium contents corresponding to emission in the blue spectral range.

To address this question from a theoretical perspective, the models developed as part of the parameter database have been applied and also extended to the analysis of vertical and lateral carrier transport in InGaN/GaN MQWs by means of atomistic and multi-dimensional continuum-based models. More specifically the established tight-binding model and non-equilibrium Green's function (NEGF) calculations have been used to gain insight into the impact of random alloy fluctuations on the transport properties of the systems under consideration. The results have been compared to results from a virtual crystal approximation (VCA), which completely neglects the effect of alloy fluctuations. The data indicate that for small barrier width the random alloy fluctuations might indeed be important for uni-polar electron transport properties. However, with increasing barrier width there seems not to be a huge difference between VCA and atomistic results. This finding is consistent with the results obtained from a here-developed 2D drift-diffusion (DD) model that accounts also for alloy fluctuations. For this work, a method for coupling atomistic and continuous finite element models (FEM) has been implemented in the TiberCAD software to study random alloy structures. First, this solver has been used to calculate the I-V characteristics of the uni-polar test structures grown by OSRAM, including alloy fluctuations

and different lateral electron mobilities. In these simulations, the theoretically predicted threshold currents were higher than the experimentally observed values. This led us to the conclusion that random alloy fluctuations in combination with other effects, such as non-linear variations of the built-in fields for instance, may give rise to the experimentally observed lower threshold voltage values for uni-polar electron transport. To study the impact of hole localization effects due to random alloy fluctuations on the transport properties, the 2D DD solver was extended, with input from OSRAM, to reproduce realistic MQW LED structures. The effects of indium fluctuations on the current-voltage characteristics and recombination profiles have been analysed extensively for different barrier thicknesses (see Fig. 2.22).

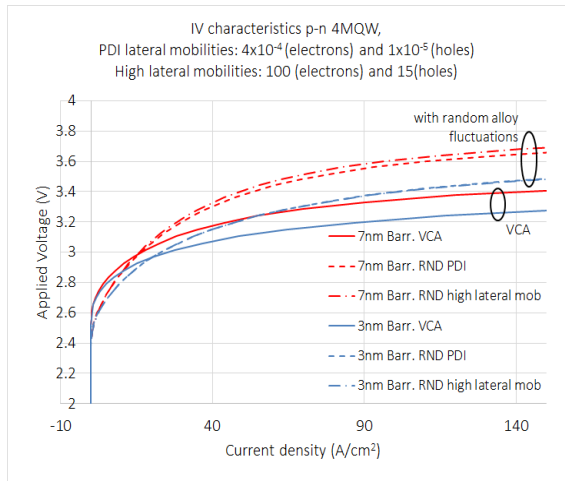

**Figure 2.22:** I-V characteristics for the 4 MQW structure with 3 and 7 nm barriers, with (RND) and without (VCA) a random alloy, and with two different in-plane mobility sets [all in  $\text{cm}^2/(\text{V}\cdot\text{s})$ ].

Interestingly, results reveal the impact of alloy fluctuations to be different to that in uni-polar structures. In fact, large differences are found between models assuming VCA and those including random alloy fluctuations. As expected, carriers flow to regions with higher indium content, which then act as recombination hot spots. Moreover, both electrons and holes take advantage of the lowering of the transport barriers in regions depleted of indium, resulting in improved transport and in a change in the carrier distribution across the active region of the device.

Further resources were devoted to another topic critical to LED performance, namely, the recombination dynamics in the active region. Time-resolved photoluminescence (TRPL) studies were conducted by PDI with both polar and nonpolar QWs, as well as in bulk (In,Ga)N

samples (all provided by OSRAM). Experiments reveal fundamental differences in the behaviour of polar and nonpolar QWs resulting, respectively, in power law and single exponential PL decays. These results are consistent with Tyndall's work demonstrating theoretically hole localization and predicting exciton-like recombination in nonpolar QWs. To further analyse the role of the polarization fields in polar (In,Ga)N QWs, PDI carried out similar TRPL measurements on green commercial LEDs fabricated by OSRAM.

### **3 Potential Impact, Dissemination and Exploitation**

#### **3.1 Potential Impact**

For the development of leading edge nanoelectronic and photonic technologies and components, there is a challenging trend towards speeding up the development and transfer cycle while keeping rapidly spiralling costs under control. TCAD system providers face strong demands to contribute to this greater speed and lower costs in development and fabrication. According to the 2011 International Technology Roadmap for Semiconductors (ITRS, Edition 2011), TCAD was at that time already saving an estimated 40% of semiconductor technology development costs and reducing the development time by about 40%.

The lack of appropriate TCAD tools can limit or substantially delay the development of new technologies. We see a significant deficiency in the capabilities of TCAD, namely the lack of suitable and calibrated models for technologies beyond the 10nm node in electronics and to treat nanoscale fluctuations in photonics that prevents its usage in the development of leading edge technologies. Density functional theory (DFT) is the most widely accepted method to treat materials on this scale, but cannot as yet treat the larger length scales that are also critical to the operations and efficiency of electronic and photonic devices. The multiscale environment developed in DEEPEN allows simulation that treats the different length scales to the required level of accuracy.

Recent market research analysis by Technavio predicts the global simulation and analysis software market to grow steadily at a CAGR of around 12% between 2016 and 2020<sup>21</sup>. The rising need for products with enhanced quality and innovation is a major driver for this market. The adoption of simulation and analysis software has increased across industries as they compete to achieve "first mover advantage" and strive to become the "prime innovator" in their field.

As evidenced by the EU 5+1 cluster, simulation covers a very broad range of applications and markets. However, electronics and photonics are among the dominant application areas. The Technavio report estimates that the automotive and electrical and electronics industries together accounted for over 50% of the total simulation market share in 2015. This market area is directly addressed by DEEPEN partners Synopsys and TiberLab as software providers and by OSRAM as a major LED manufacturer and end-user of simulation software. As example, Synopsys has an annual turnover (revenue) of more than €2bn, with Sentaurus being one of its key simulation tools. Likewise, OSRAM Opto Semiconductors has an annual turnover exceeding €1bn, evidence of the overall scale of the simulation market and of the technology areas of direct relevance to DEEPEN.

DEEPEN has significant potential economic and societal impact, with the multiscale simulation environment specifically dedicated to support the design, analysis and optimization of critical electronic and photonic devices especially relevant to address the "grand challenges" of our society, with direct impact likely in areas such as energy and environment, and longer term relevance to challenges in health, safety and mobility. The outcomes of DEEPEN contribute significantly to European innovation at several levels (see Fig. 3.1). Firstly, the development and validation of research TCAD tools can drive the research agenda in nanoscience and nanotechnology, both for DEEPEN partners and also in the wider community. At the next level, the tools developed will be of significant value to modelling systems providers such as DEEPEN partners TiberLAB and Synopsys, both of whom are already exploiting DEEPEN developments in their product portfolio. While manufacturing seems to be attracted to other world regions with cheaper labour costs, Europe needs to create jobs higher up in the value chain. This implies maintaining the capability to design superior electronic and photonic devices and systems. The multiscale

---

<sup>21</sup> <http://www.technavio.com/report/global-product-lifecycle-management-simulation-and-analysis-software-market>

simulation environment developed in DEEPEN and the participation of OSRAM in DEEPEN are key enablers to achieve this goal: OSRAM's current significant expansion in Regensburg is underpinned by projects such as DEEPEN. Overall, DEEPEN aims to significantly strengthen European competitiveness, with clear routes to successful exploitation of the technology.

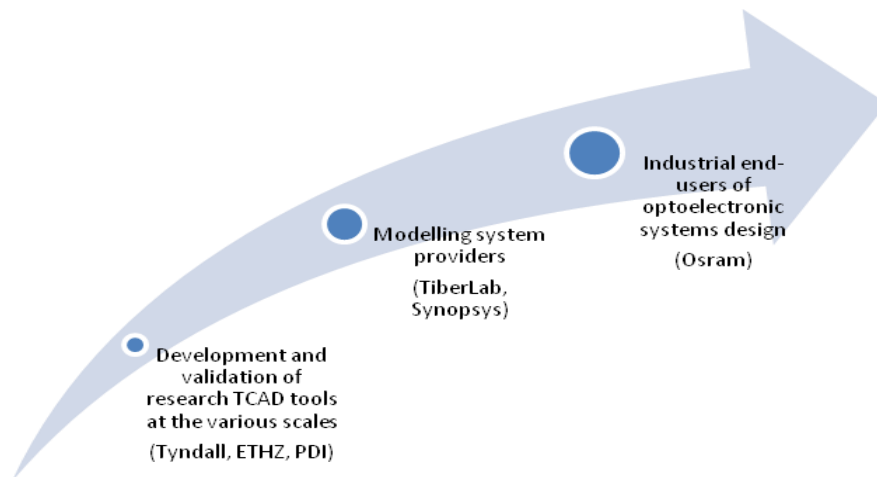

**Figure 3.1:** Value chain on TCAD products

In summary, the software developed in DEEPEN addresses key challenges faced by simulation for the design, analysis and optimisation of critical and large-scale nanoelectronic and photonic technologies. We describe in the next sub-section the wide range of activities undertaken by DEEPEN partners to disseminate the project results and outcomes, followed in Sec. 3.3 by the consortium and partner plans to provide leading edge innovation to exploit the capabilities developed during the project.

### 3.2 DEEPEN Dissemination Activities

A wide range of approaches have been used by DEEPEN partners to support the dissemination and exploitation of DEEPEN outputs and know-how. Highlights of the dissemination activities include:

- Lead organization of a CECAM Workshop on “Multiscale Simulation: from Materials through to Industrial Usage”<sup>22</sup>, in collaboration with other projects in the 5+1 multiscale simulation cluster
- Lead organization of Training School and Semiconductor Workshop: Euro-TMCS II Theory, Modelling and Computational Methods for Semiconductors<sup>23</sup>
- Strong dissemination to wider community, with **23 papers** published, **15 invited presentations** and **47 contributed presentations** at conferences and workshops during project period
- Full interaction with 5+1 multiscale simulation cluster and development of MODA and workflow for the DEEPEN project, as described below
- Presentation of Open Source environment on TiberCAD website [16]
- Use of the DEEPEN web site <http://www.nmp-deepen.eu/> to support OS development and also to publicise CECAM and Euro-TMCS II, thereby generating significant traffic to the site

<sup>22</sup> <https://www.cecarn.org/workshop-1255.html>

<sup>23</sup> <http://www.tmcuk.org/conferences/Euro-TMCSII/>

- Press releases at start and end of project, leading to uptake in Irish national press, on specialist websites and by cordis.eu
- DEEPEN-related article in Engineering Ireland eJournal<sup>24</sup> on 14 February 2017
- Release of DEEPEN related results with Synopsys software release N-2017.09
- Synopsys running workshop sessions with specially selected customers to introduce DEEPEN results in the first half of 2017.

Details of the DEEPEN-related publications and presentations are presented in Section A of the report on Use and Dissemination of Foreground, and are also available on the DEEPEN website<sup>25</sup>. Further details of the post-project dissemination and exploitation of results are presented in Sec. 3.3. DEEPEN was one of five projects funded under the NMP.2013.1.4-1 call, targeted at “Development of an integrated multi-scale modelling environment”. A key part of the DEEPEN dissemination activities were related to interaction with the cluster of projects funded under this call, and also with a further Coordination and Support Action project, ICMEg<sup>26</sup>, one of whose main objectives was to stimulate knowledge sharing in the field of multiscale materials design. We summarise below key activities undertaken as part of the 5+1 Cluster, including our organisation of the CECAM workshop on multiscale simulation, as well as overviewing follow-on cluster plans following the end of the project. A brief overview is also presented of the Euro-TMCS II conference. This meeting traditionally attracts strong interest from researchers who are working across a spectrum of different modelling activities and so provides an ideal opportunity to highlight the DEEPEN open source multiscale environment to a relevant semiconductor materials and devices audience.

### ***Interaction with Other Funded Multiscale Projects***

The DEEPEN partners strongly engaged with the other funded multiscale projects during the full project period. This included leading the preparation for and hosting the CECAM Workshop on “Multiscale Simulation: from Materials through to Industrial Usage” in Dublin (5-7 Sept. 2016), as well as the preparation and delivery of an example workflow and MODA for the DEEPEN project.

Further meeting participation has included:

- Attendance and presentation at the launch of the Multiscale Cluster at the 1st Workshop of The EU Multi-scale Modelling Cluster, held at Industrial Technologies 2014 Conference in Athens (April 9-11 2014)
- Lead organiser of a symposium on “Multi-scale multi-physics modelling for nanomaterials and systems by design” at Materials Science and Engineering Congress, MSE2015, Darmstadt 23-25 September 2014 Three partners attended Multiscale Cluster workshop, Darmstadt 26 September 2014
- Three partners attended and presented at The 3<sup>rd</sup> EMMC workshop on "Interoperability in Multiscale Modeling of Nano-enabled Materials", Jyväskylä (May 2014), coordinated by SimPhoNy.
- Attendance at the EMMC / ICMEg InterOperability Workshop in Brussels on 10 March 2017, where Fabio Sacconi (TIBER) contributed to a presentation on HDF5 as a pragmatic basis and viable approach for linking of models in a file based interoperability approach.

With funding for the 5+1 cluster mainly ending in December 2016, leadership of the discussions and work on metadata and interoperability has now been taken by the recently funded Coordination and Support Action, EMMC-CSA<sup>27</sup>. This CSA is undertaking a number of actions, including the establishment of an Interoperability and Repositories Advisory

<sup>24</sup> <http://www.nmp-deepen.eu/press/tin-based-alloys-offer-platform-for-energy-efficient-electronic-devices/>

<sup>25</sup> <http://www.nmp-deepen.eu/publications-and-presentations>

<sup>26</sup> <http://www.icmeg.eu/project/info/>

<sup>27</sup> <https://emmc.info/the-emmc-csa-project-start-and-kick-off-meeting/>

Group (IRAG). The DEEPEN coordinator has accepted to join the IRAG and participated in the first IRAG teleconference on 7 December 2016. The role of the IRAG will be to provide input, feedback and support in establishing a common vocabulary and taxonomy for materials modelling, metadata developments to support interoperability in materials modelling and the linking of relevant repositories covering all industrial application fields, all materials, all databases etc.

In the near term, IRAG members will be involved in two important tasks:

- Participate in a standardisation process of materials modelling vocabulary and classifications, based on the Review of Materials Modelling and MODA. The process will be coordinated by the German Standards Organisation DIN and should hopefully lead to a so called CEN Workshop Agreement (CWA).
- Provide input into proposals for Metadata Schema and Materials Modelling Ontology for semantic interoperability.

The DEEPEN coordinator attended a meeting in Brussels on 17/18 January 2017, covering the kick-off meeting for the CWA process, as well as an IRAG kick-off meeting and discussion of metadata schema.

### ***DEEPEN Workflow and MODA***

It was agreed at the 3<sup>rd</sup> Interoperability Workshop in Jyväskylä that, given the diversity in the cluster, it is important to focus initially on common higher level specifications. This implied the need to focus initially on a high level description of each task rather than details of the implementation. A generic abstract representation is therefore initially needed. All of the cluster projects agreed to produce a workflow in a standard format to describe the activities in the project (see Fig. 2.1). They agreed in addition to provide a higher level metadata description of the models being used in the project and of the coupling between the different models. With input from NMPB materials modelling project officers, the structure of the higher level metadata description evolved into what is now referred to as the MODA (MOdelling DAta), a fiche that should contain all elements that are needed to describe a simulation. The information in the MODA spans from end-user information to the computational modelling details.

The MODA begins with a general description of the User Case, giving the properties and behaviour of the particular material, material behaviour, manufacturing process or in-service-behaviour to be simulated. It then breaks the multiscale simulation down into a workflow involving a chain of models, with each model following the classification in the European Review of Materials Modelling (ROMM)<sup>28</sup>. The DEEPEN example workflow links together three different models:

- Semi-empirical tight binding potential (TB) model (1.1.2.2 in RoMM)
- Non-Equilibrium Green's Function Model for Transport of Electrons (1.4 in RoMM)
- Semi-classical Drift-diffusion model (continuum model 4.2 in RoMM).

DEEPEN created the first advanced draft of the Semi-classical Drift-diffusion model, subsequently refined by EXTMOS. In collaboration with Anne de Baas and others, Mathieu Luisier from DEEPEN also led the preparation of the MODA description for the Non-Equilibrium Green's Function (NEGF) Model for Transport of Electrons, and helped to prepare the agreed version of the NEGF description for inclusion in the ROMM. Details of the DEEPEN MODA and workflow are included in the latest version of the ROMM, released in early 2017.

---

<sup>28</sup> [http://ec.europa.eu/research/industrial\\_technologies/modelling-materials\\_en.html](http://ec.europa.eu/research/industrial_technologies/modelling-materials_en.html)

## **CECAM Workshop on “Multiscale Simulation: from Materials through to Industrial Usage”**

DEEPEN led the organisation of the final cluster event (September 2016), a CECAM Workshop on “Multiscale Simulation: from Materials through to Industrial Usage”, with support from all cluster projects, in particular Joan Adler from SimPhony, and also from Gerhard Goldbeck (Project Technical Adviser). Details of the Workshop are reported in D7.5: Training School, DEEPEN Workshop and Press Release<sup>29</sup>.

The Workshop succeeded to attract a strong and well balanced set of speakers (Fig. 3.2), including representatives from each of the 5+1 Cluster of projects, other relevant EU projects, industry, and leading US projects and speakers. This breadth and balance of leading speakers ensured a high level of interaction throughout the Workshop. **Day 1** set the scene regarding the **current status and vision** for multiscale simulation. **Day 2** shared **current practice**, with presentations in the morning from the 5+1 cluster and a poster session and plugfest in the afternoon. Finally, **Day 3** addressed **next steps and challenges**.

Day 1 included a **panel discussion on interoperability**. The discussion kicked off with comments on the classification of models, why this is needed and how this could be achieved. Overall the panel and the audience appreciated very much the multiscale approach, however, it was also highlighted that providing and agreeing the classifications is an extremely difficult task. This discussion was followed by further discussion on keywords and metadata. This discussion focused on the requirements of industry partners and how they will use such a framework for their simulation and design purposes.

The meeting concluded on day 3 with a further **panel discussion on next steps**. This aimed to identify and agree critical next steps for the widespread uptake of Multiscale Simulation going from Materials Modelling through to Industrial Usage. The discussion was mainly centred around the MODA and how a MODA is defined and used. It was argued that it is not a flowchart but it gives indication of the parts involved in the modelling process of a given project. A focus of the discussion centred around interoperability and integration, model development and validation. Given the participation from organizations in Europe and USA, there was a healthy discussion on how European and US initiatives can work together. A strong commitment from both sides of the Atlantic was expressed with the idea to start with relatively small and focused collaborations, which will help define how to best work together.

### **Euro-TMCS II Theory, Modelling and Computational Methods for Semiconductors**

To disseminate the results of DEEPEN to the relevant research community, DEEPEN also hosted Euro-TMCS II Theory, Modelling and Computational Methods for Semiconductors, in December 2016). This meeting included a 1-day training event for PhD students, and provided an ideal opportunity to make the relevant research community aware of DEEPEN's work as the project was concluding. Euro-TMCS II ran over three days (7 – 9 December),



**Figure 3.2:** Attendees at CECAM Multiscale Simulation Workshop

<sup>29</sup> <http://www.nmp-deepen.eu/contentfiles/D7.5-Workshops.pdf>

with the objective of bringing together leading experts in the field of theory of group IV, III-V and wider semiconductors together with postdocs and students in their early stages who can benefit from an introduction to a very vast field at this influential point in their careers. The meeting was sponsored by DEEPEN, with co-sponsorship from the EU MultiscaleSolar COST Action and also from the Institute of Physics and from Failte Ireland.

The meeting began with an **introductory day training event** targeted specifically at PhD students and early stage researchers (Fig. 3.3), with high level lectures on the most used methodologies in the field, including a presentation by Dr. Fabio Sacconi (TiberLab) on semiconductor device simulation. The introductory day tutorial presentations covered the key scales required for semiconductor simulations, with five tutorials presented by leading experts:



**Figure 3.3:** Discussions at Euro-TMCS introductory day training event

- **Matt Probert** (University of York) “Plane-Wave DFT and LDA”
- **Ben Hourahine** (University of Strathclyde) “DFT-Tight-Binding Theory”
- **Stefano Sanvito** (Trinity College Dublin) “Non-equilibrium Green’s Function Methods”
- **Fabio Sacconi** (Tiberlab) “Device Simulations”
- **Jacky Even** (CNRS) “Modelling of halide perovskites”

The second and third days of the Workshop (Fig. 3.4) were divided into six separate sessions, namely:

- 2-D Materials
- Nanostructures
- Density Functional Theory and Fundamentals
- New Materials
- Hybrid Perovskites and Solar Cells
- Device Simulations

with 24 contributed talks, 13 poster presentations and five invited talks from leading international experts:

- **Thierry Amand** (INSA Toulouse) “Exciton dynamics & spin-orbit effects in atomically thin TMDC & their alloys”
- **Ivana Savic** (Tyndall National Institute) “Modelling of the thermoelectric properties of materials near soft mode phase transitions”
- **Patrick Rinke** (Aalto University) “Charge transfer at oxide/organic interfaces”
- **Mark van Schilfgaarde** (King’s College London) “Hybrid Perovskites: unusual optical properties of MAPI”
- **Yuh-Renn Wu** (National Taiwan University) “Challenges in Optoelectronic Device Simulation”



**Figure 3.4:** Coffee time at Euro-TMCS

DEEPEN-related results were presented by Fabio Sacconi on the tutorial day and in five oral presentations during the meeting (Oliver Marquardt, PDI; Fabio Panetta, Tiberlab; Ramzi Benchamekh, Tyndall; Daniel Tanner, Tyndall; Pedram Razavi, Tyndall), ensuring wide dissemination of the outcomes of DEEPEN through the Workshop.



### 3.3 Exploitation of Results

Uptake by industrial and academic design teams of the multiscale and multimodel framework developed is vital to successful exploitation of the project results. To ensure the project's relevance, we have benefited from real involvement by three leading industry partners in the multiscale design tool specifications, namely an SME specializing in multi-scale simulation (TIBER), a major TCAD provider (SNPS) and a major designer and manufacturer of solid state lighting (OSRAM), all of whom have clear routes for exploiting the project results. The outcomes of DEEPEN will therefore contribute significantly to European innovation at several levels, as illustrated in Fig. 3.1. The Open Source Multiscale environment is being made available through the TiberCAD and DEEPEN websites, to ensure that the parameter database and open source APIs will be widely available. In addition, each of the DEEPEN partners has well developed technology implementation plans for the exploitation of the capabilities and knowledge developed in DEEPEN. We present here these plans, starting from the bottom of the value chain in Fig. 3.1.

#### **Academic Partners**

The academic partners are exploiting DEEPEN in their education, training and wider research developments. This includes training of PhD students employed on the DEEPEN project by PDI (Felix Feix), ETHZ (Christian Stieger) and Tyndall (Daniel Tanner, Amy Kirwan). Research students working on other projects at the three institutes also benefit from the knowledge developed through DEEPEN, while DEEPEN-related material is also informing undergraduate project work at Tyndall and masters projects at ETHZ and at PDI.

#### **TYNDALL**

The continued development of the TiMeS software package in conjunction with open source codes such as OpenMX and Quantum Espresso is supporting research activities directly with industrial sponsors. For example, the simulation work being performed with these and related tools has enabled a three year contract between Tyndall National Institute and a major international corporation. This programmatic funding is currently divided between simulation and fabrication work.

EOLAS Designs Ltd is an Irish start-up company developing custom simulation tools under contract for nanoelectronics design. The company is founded by two Tyndall employees and EOLAS is committed to undertake an evaluation of the publically disseminated tools at the end of the DEEPEN project to explore their use in developing future software products and services based upon the DEEPEN open source platform.

The ASCENT research infrastructure project is a European Union funded 'starting community' for advanced nanoelectronics design and simulation<sup>30</sup>. The metadata structures and common data formats developed by DEEPEN and the cluster partners within NMP are being provided to the infrastructure providers (Tyndall, imec, Leti) to help establish these standards within the broader nanoelectronics simulation community.

The modelling capabilities being developed in DEEPEN are also available to other national and European projects and are also being used to support new proposals and new research lines at Tyndall. One new national project has recently been funded by Science Foundation Ireland. This project is using the capabilities developed in DEEPEN to investigate the "Multiscale Simulation and Analysis of emerging Group IV and III-V Semiconductor Alloys", including the investigation of GeSn tunnel FET devices and of dilute bismide optoelectronic devices.

In conclusion, the DEEPEN project has triggered the development of important building blocks and has already delivered results relevant to industry. Tyndall expect to continue on this track beyond the end of the project and are open for collaboration in potential future projects.

---

<sup>30</sup> <http://www.ascent.network/>

## **ETHZ**

DEEPEN has further strengthened the ongoing interactions between ETHZ and Synopsys. In the final year of DEEPEN, this cooperation with Synopsys led to a research grant for ETHZ (directly paid by Synopsys) to extend the QT-Solver code. The modelling capabilities developed in DEEPEN are also supporting new proposals and research lines at ETHZ. Two projects leveraging DEEPEN developments were recently funded: one by the Swiss National Science Foundation on the investigation of InP/GaAsSb bipolar transistors and one by ETHZ through its internal grant systems on the simulation of van der Waals heterostructures. Both efforts take advantage of the multi-scale modelling environment combining VASP, Wannier90, and OMEN that was implemented as part of DEEPEN. This platform, mainly assembled by Christian Stieger, is currently used by 5 other researchers at ETHZ. It is expected to play a significant role in the national and European proposals that will be submitted in the future, and is also being disseminated through papers and presentations, including a high number of DEEPEN-related invited presentations.

## **PDI**

PDI's participation in DEEPEN strongly supported the validation of the DEEPEN simulation environment. In addition, DEEPEN calculations by TIBER have helped PDI to develop a consistent understanding of the experimentally observed optical properties of nanowire LEDs, benefitting their understanding of III-N nanowire growth and optimisation, for development of efficient visible light sources. The validation work by PDI has also benefitted the external visibility of DEEPEN, through publication in top-tier journals and presentations at major meetings. These efforts have been very successful, as documented in the DEEPEN list of publications and presentations [25]. The strong interactions throughout the project on III-N materials and devices are expected to lead to 5 further DEEPEN-related publications, one of these in collaboration with TiberLAB<sup>31</sup> and another in collaboration with Tyndall and OSRAM.

### ***Modelling System Providers***

Both modelling system providers in DEEPEN plan rapid exploitation of the capabilities developed in DEEPEN.

## **TIBER**

The multiscale simulation environment developed in DEEPEN will be of great help to foster Tiberlab's mission towards the realization of a software platform, named TiberCAD, for integrated multiscale simulation, capable of modeling a device at different scales, using different physical models and connecting them in a self-consistent way. The new material databases and parameterizations of physical models developed in the project are expected to deeply raise the capabilities and performance of the TiberCAD software tool. Tiberlab is the key partner driving the development of the Open-Source Multiscale (OS) environment, and is therefore very well placed to take advantage of the multiscale approaches employed in this project for the accurate description of electronic and optical properties of LEDs and related devices.

We expect the DEEPEN project will help the integration of TiberCAD in several multiscale frameworks, giving Tiberlab the opportunity to take advantage of coupling with other solver tools, both continuous and atomistic. Moreover, new material databases and novel parameterizations of physical models developed in the project are expected to significantly raise the capabilities and performances of the TiberCAD software tool.

The multiscale simulation strategy employed in this project will be of great help to promote Tiberlab's vision, focused on industrial innovation and on technology transfer from the research world to market applications. The project will support Tiberlab's market penetration in the field of multiscale simulation, thanks to the connection provided with other

---

<sup>31</sup> <https://arxiv.org/abs/1704.01569>

OS and commercial simulation software. Through the OS common data format (CDF) it will be possible to couple the multiscale and multiphysics capabilities of TiberCAD to other tools, opening the way to a wider market of simulation users. The multiscale approaches developed in this project for the accurate description of LED devices opens to Tiberlab very interesting prospects in the optoelectronics industry market, where multiscale integrated simulation tools are hardly ever provided.

Regarding more specifically the possible exploitation of the project results regarding the multiscale environment developed in the DEEPEN project, we must say that these are limited by the OS character of this outcome of the project. Nevertheless, some ways to exploitation are indeed viable, providing that the requirements of the OS License under which the environment will be released are satisfied.

Some examples are:

- Selling of the OS environment (provided that the source code is given)
- Selling of Documentation, Tutorials, Examples
- Selling of services related to the OS environment: technical support, advanced consulting.

Moreover, while the multiscale environment provides open access both to the source code and to software documentation, Tiberlab foresees business opportunities for providing support/consulting on how to compile, handle and extend the code, and how to implement modules for new simulation tools etc.

## **Synopsys**

Synopsys is exploiting the project results via its release channels which include standard and engineering software releases, marketing material, training courses, and application examples. The material parameter database developed in DEEPEN has already fed into their AdvancedCalibration Device parameter file, which is part of Synopsys's material database, with details included also in the AdvancedCalibration User Guide for III-V based devices in K-, L-, M-, and N-releases.

The main exploitation activities are based on the simulation setups that are transferred to industrial users worldwide. Other activities relate to the release of software and parameter updates with the release cycle. We foresee that, because Sentaurus Device contributes to a considerable part of Synopsys' total revenue any improvement there will increase the market position and therefore the income.

Synopsys has identified and developed demonstrator devices that carry the new simulation methodologies, models, and parameter sets and is providing the information necessary to link Sentaurus to the open-source simulation environment. In addition to the upgrades DEEPEN has provided for AdvancedCalibration Device, Synopsys also have many pilot projects running with customers for more advanced tools like deterministic subband BTE solver, band structure and mobility calculations in confined structures, and NEGF, all of which are key to building future increases in bookings and revenue.

During the last phase of the project and after the project Synopsys are enabling the direct transfer of technology to industrial end-users by providing the new TCAD simulation methodologies and models in the format of TCAD simulation setups for direct industrial use. In addition, further Training Sessions focusing on the new capabilities of Sentaurus Device are being organised in 2017. These Training Sessions are stand-alone events, organised by Synopsys. The release N-2017.09 which will contain the major end results of the DEEPEN project will be accompanied by corresponding manual updates, training sessions, marketing and presentation material as well as application examples (see Sec. 2.5 of this report). In this way, the project results will be made commercially available to the nanoelectronics industry but also to research and academia world-wide.

### ***Industrial End User***

The work in DEEPEN has benefitted significantly from the inclusion of OSRAM as an industrial end user.

### **OSRAM**

Nitride LEDs represent a major business area for OSRAM Opto Semiconductors GmbH. Enabling this is the ability to produce highly efficient devices and, ultimately, to understand the relevant carrier transport and loss mechanisms in the InAlGaN material system. These issues were targeted in the DEEPEN project by the development and coupling of sophisticated tools that can model materials across nano and macroscopic scales. OSRAM has updated their material database and simulation capabilities based on the outcomes of DEEPEN.

OSRAM Opto Semiconductors plans the significant extension of its semiconductor fabrication capacity in Regensburg, Germany to be started in spring 2017<sup>32</sup>. This capacity extension comprises more than 30% cleanroom area and the respective increase in logistic and infrastructure.

This extension is associated with a true innovation - the transfer of new achievements from research and development (R & D) activities over the last 8 years to production. Most of these R & D activities were supported by European and German public funded projects. In this way, also DEEPEN contributed to OSRAM Opto Semiconductor's future product portfolio. Modelling plays a significant role in the design of new active layers towards increased efficacy, as required for next generations of LEDs. Thus, DEEPEN should positively impact almost every future LED generation. Therefore, a quantitative extrapolation of the exact value of DEEPEN to OSRAM is not possible. However, in 2-3 years after the project end, the first novel products of the new factory in Regensburg benefitting also from DEEPEN achievements, will start with annual revenue from those products increasing with a significant double digit cumulated annual growth rate.

400 new jobs will be created in Regensburg with the new production facility within the next 4 years. An additional 100 jobs in R & D are associated with the said novel products and will be created by 2020 in Regensburg.

---

<sup>32</sup> <https://blizz-regensburg.de/regional/osram-regensburg-expandiert-3877/>;  
<http://www.handelsblatt.com/unternehmen/industrie/osram-lichtkonzern-plant-tausend-neue-stellen-in-regensburg/19375370.html>