

Publishable Activity Report of Bioshale Project

October 2004 - December 2007

Mineral Processing

```

    graph TD
      RM[Raw Material] --> SC[Screening & Crushing]
      SC --> M[Milling]
      M --> F[Flotation]
      F --> CC[Copper Concentrate]
      F --> T[Tailings]
      
      subgraph Bio_Process [Bio Process]
        BL[Bio Leaching]
        MR[Metals Recovery]
        PLB[PLB]
      end
      
      subgraph Pre_treatment [Pre-treatment]
        CD[Carbonate Decomposition]
        SF[Shale Flotation]
        PCD[Partial Carbonate Decomposition]
      end
      
      SC --> BL
      M --> CD
      M --> SF
      M --> PCD
      
      BL --> MR
      MR --> H[hydrometallurgy]
      MR --> R[Residue & Effluents]
      
      CD --> F
      SF --> F
      PCD --> F
      
      F --> A[A]
      F --> B[B]
      
      R --> R1[Residue in previous lots & PGMs recovery]
      R --> R2[Residue]
      
      H --> R1
      H --> R2
      
      A --> CC
      B --> CC
      
      style Bio_Process fill:#ffffcc
      style Pre_treatment fill:#ffcccc
      style F fill:#ccffcc
  
```



Project n° / Acronym NMP2-CT-2004-505710 / BIOSHALE

Project Title: *Search for a Sustainable Way Of Exploiting Black Shale Ores Using Biotechnologies*

Instrument: *Specific Targeted Research Project*

Thematic Priority: *Priority 3 - NMP*

Bioshale project: A Specific Targeted Research Project co-funded by the European Commission (FP6 programme)

PROJECT GENERAL DESCRIPTION



Bioshale was a project co-funded by the European Commission (FP6 programme) that started in October 2004.

The main objective of Bioshale was to define innovative biotechnological processes for "eco-efficient" exploitation of black shale ores.

Such ores contain base, precious and "high-tech" metals (Cu, Ni, Zn, Ag, Co, Pt, Pd, V, etc.) but also high contents of organic matter and carbonates that handicap metal recovery by conventional techniques.

Three extensive deposits have been selected for R&D actions. These are: (i) a site (in Talvivaara, Finland) that, at the outset of the project, had not been exploited; (ii) a deposit (in Lubin, Poland) that is currently being actively mined, and (iii) a third site (in Mansfeld, Germany) where the ore had been actively mined in the past, but which is no longer exploited.

The social & economic benefits of the project include the continuation of mining activities in Europe (Lubin/Polkowice) and to help exploit new resources with considerable reserves (Tolvivaara). The Mansfeld site is illustrative of and supports the evaluation of the Environmental Impact of black shale ore exploitation.



FOR MORE INFORMATION

Web site: <http://bioshale.brgm.fr>

Contact - Project Coordination - bioshale@brgm.fr

BRGM - EPI 3 Avenue Claude Guillemin BP 6009 45060 Orléans cedex 2 - France

Bioshale FP6 European project: **exploiting black shale ores using biotechnologies?**
in *Minerals Engineering*, 21, 2008, 111-120

BIOSHALE PARTNERS

BRGM - Geosciences for a sustainable Earth

BRGM - *Project & WP5 leader* - France

KGHM Cuprum Ltd. CBR

CUPRUM - *WP2/topic leader, technique* - Poland

Wroclaw University of Technology

PWR - Poland

University of Opole

UO - Poland

University of Warsaw, Faculty of Biology

UW-FB - *Topic leader, Environment* - Poland

Geological Survey of Finland

GTK - *WP1/6 leader* - Finland

Helsinki University of Technology

TKK - Finland

Tecnicas Reunidas

TR - *WP4 leader* - Spain

University of Wales, Bangor

UWB - *WP3 leader* - UK

Warwick University, Biological Science

WU-BS - *Topic leader, Biology* - UK

G.E.O.S. Freiberg, Ingenieurgesellschaft mbH - GEOS - Germany

University of Mining and Geology Saint Ivan Rilski - Sofia

UMGS - Bulgaria

Czech Geological Survey

CGS - Czech Republic

With the kind collaboration of:

KGHM Polska Miedz S.A. (Poland) TVK (Talvivaara Company, Finland)

The main tasks of Bioshale project can be summarised as follows:

1. evaluation of the geological resources (geological modelling);
2. selection of metal-bearing components & biological consortia to be tested;
3. assessment of bioprocessing methods and determination of complementary hydrometallurgical processing routes for metals recovery;
4. use of new analytical tools based on molecular biology for the characterisation & monitoring of bacterial communities;
5. risk assessment relative to management of waste material from of the new processing routes;
6. techno-economic evaluation of new processes from mining to metal recovery including social and environmental impacts.

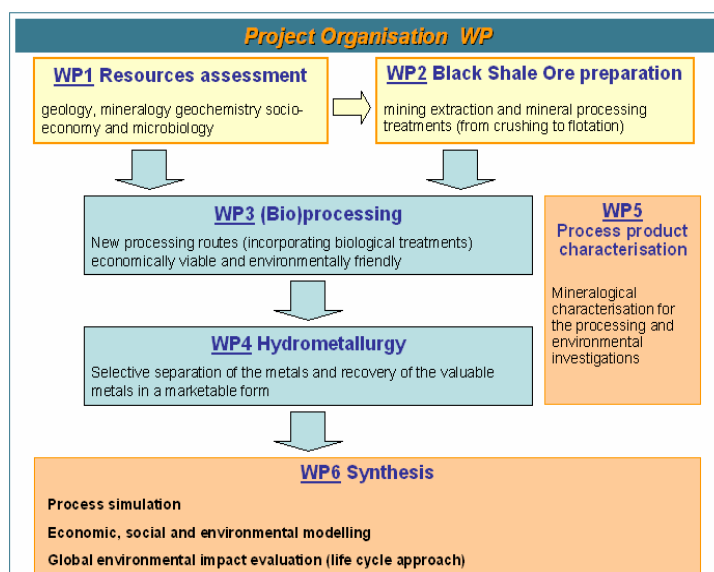

GENERAL INFORMATION

Duration:

3 years (start date 1st October 2004)

Total budget:

3.4 M€ (EC 2.3 M€)

Partnership:

13 Partners / 8 European countries

Project efforts:

553 Man Months (+226 MM Universities Own Resources)

Reporting: **22 Deliverables**

Major achievements (Process options & Academic R&D)

From a general point of view, and in the case of copper extraction technologies, the choice of the best technology is usually driven by both metal grade in the ore and total amount of resource. Nevertheless, it was demonstrated that the feasibility of a process on a given resource was also dependent on many site/resource - specific factors. Pyrometallurgy remains the main technology for metal recovery in general and especially for copper extraction.

Nevertheless, there are more and more potential niches for application of biohydrometallurgy.

Nowadays, biohydrometallurgy is taking an important place in the mining industry of non-ferrous metals either in competition or in complement of classical technologies.

Biohydrometallurgy definitely offers to the mining operators an alternative development option with attractive economics.

In term of process development, the work carried out in the frame of Bioshale was focused on two case studies, two types of "black shales" materials situated in Poland (Lubin/Polkowice Mine) and in Finland (Talvivaara deposit).

The most reasonable process options operations were described in the first 6 months of the project.

These preliminary "process options" have been studied by Bioshale consortium with the objective to develop new bio-hydrometallurgical routes for the recovery of valuable metals from black shale ores and/or concentrates.

From the first results obtained in the different laboratories, some new "options" were also proposed by Bioshale consortium.



Development of heap bioleaching operation in Finland by TVK company on Talvivaara deposit.

In both cases, the work on process options assessment took into account the current situation on the target sites in Poland and in Finland.

- In the case of Lubin, there is an existing concentrator plant combined with a smelter that extracts mainly copper and silver. A copper concentrate is produced there, along with an "enriched shale fraction" (or "middlings") which causes trouble in the flotation circuits. A second mine (Polkowice) located close to Lubin produces a similar concentrate, but which is more enriched in PGEs. Lubin ore contains disseminated sulphidic particles, closely associated with organic matter.
- The most valuable metal in the Talvivaara deposit is Ni, while Co, Zn and Cu are also present in significant quantities. At the beginning of Bioshale project, a large-scale industrial project evaluating heap leaching technology to recover metals from the Talvivaara ore was under evaluation. The Talvivaara black shale is a metamorphosed black shale (black schist) that contains mainly graphite.

Combining all participant contributions, a detailed analysis of all process options including their strengths and weaknesses was carried out and presented in Bioshale mid-term report.

The main conclusion concerning the process alternatives can be summarized for the principle "samples" of Bioshale project (Lubin & Talvivaara).

Lubin Process Options

Biobleaching tests showed that the Lubin black shale middlings and concentrate fractions were amenable to biobleaching, with extraction of up to 98% of the copper. A variety of microorganisms from different phylogenetic groups were used successfully at widely different temperatures, ranging from 30°C to 78°C. Although a range of heterotrophic microorganisms as well as some basophilic chemolithotrophs were able to leach copper from black shales, the results were far inferior to those obtained with chemolithotrophic acidophiles.

Biodegradation of the organic matrix of black shales (Lubin ores and concentrates) was more difficult to achieve. No evidence of biodegradation was found with acidophilic heterotrophic bacteria. Experiments with neutrophilic microorganisms have been more successful; their positive impact on metal recovery efficiency remains to be quantified at larger scale.



Amongst the various process options tested, two were examined in more details: continuous biobleaching of Lubin copper concentrate using "stirred tank" technology; biobleaching (or atmospheric leaching) using "middlings" after pre-treatment with acid to destroy carbonate minerals, or following selective flotation.

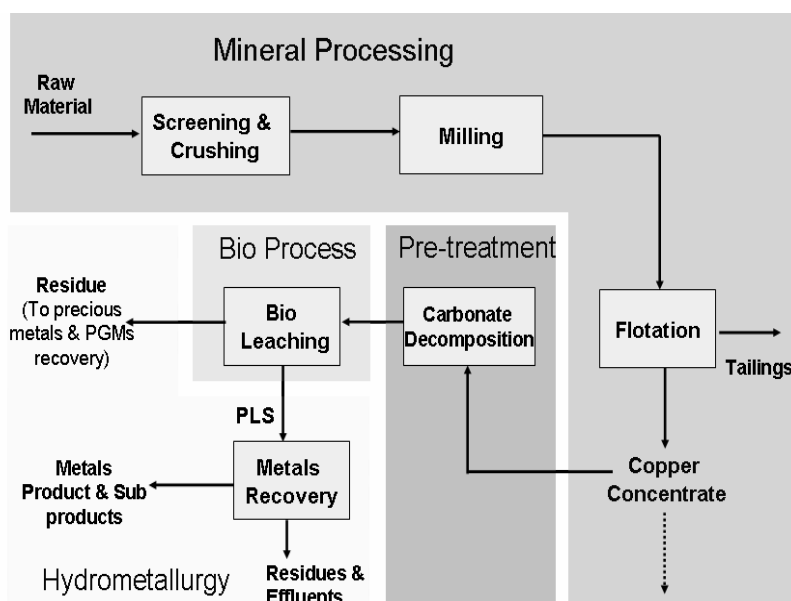

Bioshale process options on Lubin samples: biobleaching of Copper concentrate

Following successful batch culture tests with the pre-treated (non oxidative acid leaching) materials, processing in continuous conditions was realised to determine the specifications for the application of the stirred tank technology to a sulphide concentrate from black shale ores. The work carried out on the downstream processing was also a technical challenge, specifically the recovery of silver from the bioleached residues.

The best copper recovery obtained in the continuous operation was 92%, and a hot brine leaching of the bioleach residue (PLINT process) allowed to recover 92% of the silver. A preliminary techno-economic evaluation of Lubin concentrate bioprocessing including biobleaching, copper and silver recoveries demonstrated the potential economic feasibility. Recovery of silver plays an important role in the economy of the process. A comparative analysis of the new bioprocessing route with other processing technologies was performed. The comparison showed that "Bioshale process" costs was comparable with the existing technologies, with a lower investment cost in comparison with the smelting technology.

Several process options concerning the Lubin middlings were considered. This material has very similar properties to the shale ore. Although it was demonstrated at laboratory scale that the material was relatively easy to bioleach, and its use could reduce the material flow in, and improve the total efficiency of the flotation circuit, a direct (bio)leaching of the middlings did not appear to be economically viable because of the low copper grade.

Selective shale flotation (including bioflotation) of the Lubin middlings was tested. The flotation experiments proved that upgrading the middlings was very difficult.

Atmospheric leaching of Lubin shale middlings with oxygenated sulphuric acid with addition of Fe(III), performed at temperature up to 90°C, clearly showed that the process can be effectively applied, due to the favourable mineralogical composition.

Two stage bioleaching of Lubin middlings (neutrophilic + acidophilic bioleaching) was also considered in case it would be demonstrated that shale organic matter degradation was necessary to recover rare and noble metals. Biodegradation of organic matter, extracted from the shale, and synthetic metallo-organic complexes (metallo-porphyrins), were examined at neutral pH.

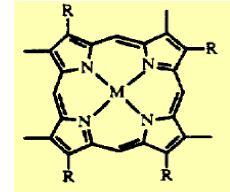

In conclusion, direct bioleaching or chemical leaching of the concentrate is technically and potentially economically feasible. The option of bioleaching the middlings in perfectly agitated tanks looks economically unattractive, while the consequences of bleeding the middlings stream on the material balance of the entire circuit are still not established and difficult to evaluate.

Talvivaara process options

The Talvivaara deposit belongs to the Talvivaara Mining Company Ltd. The grade of the Zn-Ni concentrate obtained from Talvivaara ore remains too low to make continuous stirred bioreactor technology viable. From a technical point of view, two pilot plant experiments, using heap bioleaching technology were carried out simultaneously on Talvivaara ore: one of them by the Geological Survey of Finland (GTK) within the Bioshale project and the other at the deposit site by the Talvivaara Mining Company Ltd.

In Bioshale project, several R&D actions were undertaken both on the GTK tower (simulation of heap leaching technology) and on TVK bioheap leaching demonstration operation (on site). These actions included microbial monitoring by molecular biology; complementary bioleaching tests at lab-scale (designed consortia; high temperature column leaching...); and modelling of heat transfer in the bioheap. The work was coordinated in collaboration with TVK.

Source GTK



Development of Heap bioleaching operation in Finland by TVK company on Talvivaara deposit.



The GTK pilot column for heap bioleaching tests was inoculated with a mixed culture of acidophiles enriched from waters near the Talvivaara ore body. In March 2005, the pilot column tests started at outdoor temperatures of -10°C and reached $+25^{\circ}\text{C}$ warm effluents containing Fe, Mn, Zn and Ni within a week, providing a strong indication of the applicability of the process in sub-arctic environmental conditions.



The TVK demonstration heap indicated that high temperatures (up to at least 80°C) were an inherent part of the process operation. It provided direct relevance to the investigation of microbial activity in metal extraction at high temperature. Laboratory leaching columns were used to simulate the heap leaching process. The role of the microorganisms in extraction of various metals from the ore (nickel, zinc, cobalt, and copper) was established and the advantages of a microbial process were clearly demonstrated.

The positive effect of decreasing ore particle size on leaching efficiency was demonstrated at 37°C using a mixed population of acidophiles, including mesophilic and moderately thermophilic acidophiles. Manganese and nickel were leached effectively in columns. The composition of the microbial population radically changed over the 40 week incubation period. Indigenous (Gram-positive) acidophiles were frequently detected in mineral leachates and were particularly important in the early stages of mineral dissolution.

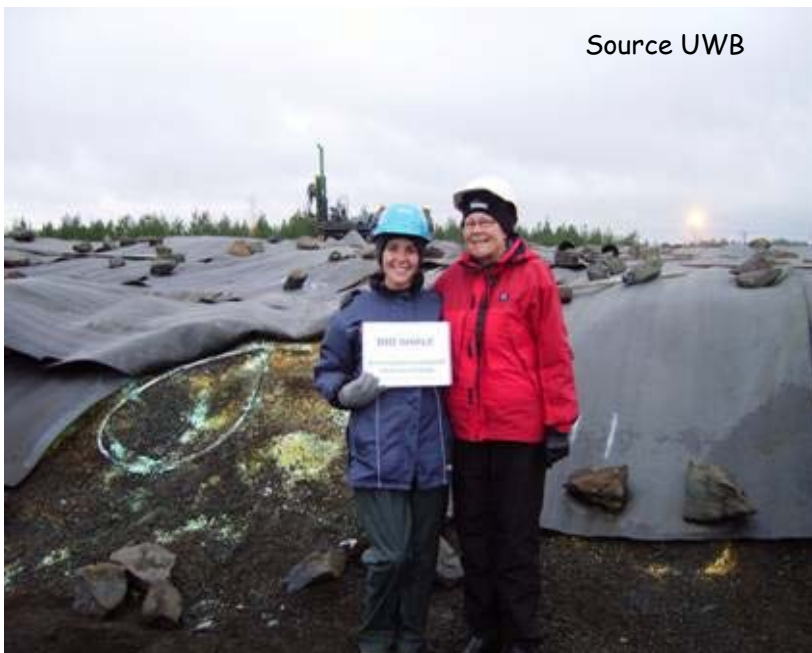

The microbial monitoring of the pilot bioleaching tests, on-site in Talvivaara and at GTK in Outokumpu, was implemented. The microbial populations in each operation were studied by cultivation (e.g. enumeration and isolation of acidophiles on solid media) and by biomolecular analysis.

A wide range of acidophiles have been isolated from samples of the heap solutions and solids, and include many acidophiles known to be important in bioleaching. These include both mesophilic and moderately thermophilic acidophiles, with the former type proving to be more prevalent.

In June 2007, TVK decided to invest 452 MEUR for the period 2007 to 2010 for the development of the mine. In September 2007, some 5000 persons are seeking employment in Kainuu region and the mine development has been estimated to generate some 3200 person-working-years. When in operation, the direct need for labour force might be 400 person-years in Talvivaara. The mine will additionally promote generation of some 600 workplaces at bulk chemical producers and smelters and about 1500 new working places are expected to be generated in the service sector. The Talvivaara deposit has about 340 Mt of resources with an estimated value of 6 700 MEUR during mine life of 25 years. The anticipated production is equivalent to 2.3% of the world Ni-production, and thus will increase Europe's Ni production by 100%.

Academic Research actions – Main Outputs

In addition to the development of bioprocess options, some more academic scientific research was carried out Bioshale project.

1. Production of new scientific data on noble metals occurrence (PGE,...) in black shales.
2. Research into the identification of noble metal carriers in metal rich shales in order to explain the mechanism of the origin of noble metals in various black shales worldwide.
3. Participation in the development of bioleaching technologies for copper recovery that can be applied to multi-element (metals) concentrates and black shale ores.
4. Demonstration of the ability to bioleach metals from black shale ores that contain organic matter.
5. Optimisation of silver recovery from residues after bioleaching.
6. Study of phenomena governing bacterial adhesion, role of cell surface properties in adhesion and bioflotation processes.
7. Bioprospecting at all three sites for (novel) bioleaching microorganisms, especially those suitable for use in the various bioprocessing options considered in the Bioshale project.
8. Extension of the known habitats of mineral oxidising acidophiles, as well as general characterisation of microbial populations associated with black shale ores.
9. Study of the microbial ecology of the TVK heap using molecular biology tools.
10. Modelling and simulation of heat transfer using data from both pilot operations (GTK and TVK).

Environmental aspects:

Global environmental impact evaluation of present black shale deposits during and after mining activities was prepared for the area after mining (Mansfeld), during mining (KGHM Polska Miedź) and before mining (Talvivaara).

Evaluation of the effect of new technologies to the environmental stress of black shale mining was estimated for Talvivaara and KGHM Polska Miedź. Recommendations for (a) environmental protection during mining and (b) remediation after mining for each of the technologies were presented as an output from WP1-WP5, using EMAS, Directives 85/337/EEC and Directive 97/11/EC

For Global environmental impact evaluation, an evaluation tool was prepared by GTK. The comparison of all studied cases clearly showed the largest environmental impact of residue after mining processes in Mansfeld and KGHM Polska Miedź, which use classic method of metallurgy.

It was assessed that the environmental impact may be decreased by 50% with the use of new biotechnology in case of KGHM Polska Miedź.

Waste samples from new biotechnological process showed relatively good chemical stability but neutralisation and some kind of waste stabilisation is needed as shown in the chemical weathering tests.

In the case of Talvivaara, there is obviously an environmental impact linked with the development of a mining project, but it can be noted that heap bioleaching will have the lowest impact when compared with other technical options. The use of the bioleaching method allows to utilize the complete ore deposit with smaller energy consumption, a smaller amount of by-product, as well as fewer discharges.

In both cases using biotechnological option, a special wastewater treatment is necessary to reduce metal concentration and neutralization to the regulatory limits.

Project Reporting - Deliverable list & Dissemination of Knowledge

The following reports were produced by the Bioshale consortium since the beginning of the project. All of these reports are confidential, but abstracts are available on the Bioshale web site & the main results have been or will be disseminated to the public.

N°	Name
1.1	Characteristics of the black shale deposits
1.2	Bioprospecting of black shale ores, mine spoils and tailings, and selection of efficient bioleaching microbial systems
2.1	Environmental impacts
1.3	Environmental impacts
2.2	New methods for selective extraction and beneficiation of black shale ores
2.3	Environmental impact of tailings - inventory of microbial ecosystem
3.1	Selection of bacterial consortia for process scale-up tests
3.2	Study on the applicability of bioflotation
3.3 & 3.4	Preliminary Process(es) flow-sheet, lab-scale pilot specifications and operations
4.1	Definition: Process variant selection options and test work programme
4.2	Technical aspects: Leaching tests results with Lubin and Talvivaara ores
4.3	Technical aspects: downstream treatment results
4.3 & 5.3	Environmental & biological aspects
5.1	Ore characterisation
5.2	Product test behaviour
6.1	Report on mid-term evaluation of the new processing routes
6.2	Geological modelling report
6.3	"Process simulation report & evaluation of new process routes: Polish Case"
6.4	Report on environmental impact of black shale deposits
6.5	"Evaluation of the new bioprocessing routes to improve the beneficiation of the black shale ores - Talvivaara Case".

A general presentation of Bioshale project, on behalf of Bioshale consortium was given by the coordinator during the following conferences.

- BioHydromet 07, Falmouth, UK May 1-2, 2007

Beside the general presentation, 5 papers (oral presentation or posters) directly related to R&D work in the frame of Bioshale were published in the conference proceedings CD-ROM (Available on request by emailing to jon@min-eng.com - MEI Online).

Following this conference, a general paper presenting the main aspects of Bioshale project was written and proposed to Minerals Engineering Journal.

After being reviewed this paper was accepted for publication.

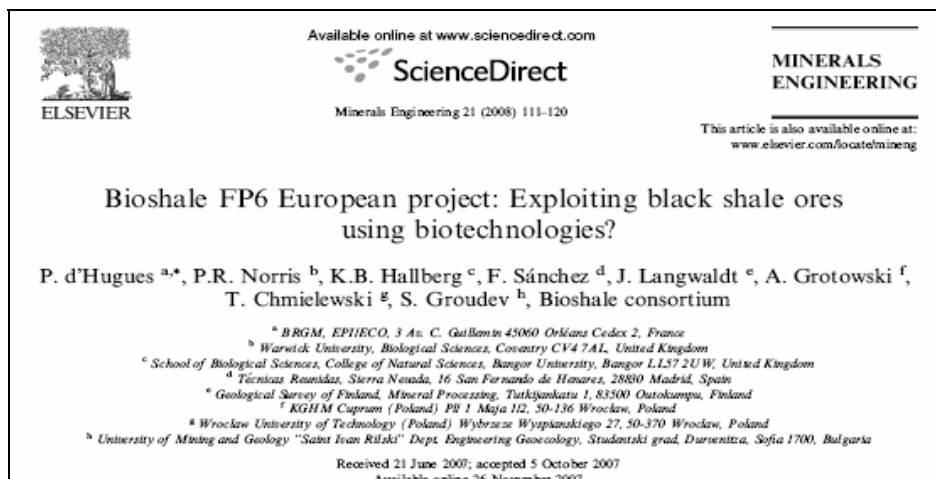

- **IBS 2007 Frankfurt, Germany, 2-5 September 2007.**
Beside the general presentation, 12 papers (oral presentation or posters) directly related to R&D work in the frame of Bioshale were published in the Symposium proceedings Biohydrometallurgy: From the single cell to the environment (IBS), edited by A. Schippers, W. Sand, F. Glombitza, S. Willscher, Trans Tech Publications LTD, Switzerland.
- **XII International Conference of Mineral Processing, Szklarska Poreba, September 17-20, Poland, 2007**
In September 2007, within the frame of a conference organised by PWR, a special session was dedicated to the presentation of Bioshale project main results.
It was also the opportunity for the project coordinator to give a key note lecture entitled: Biohydrometallurgy: An opportunity for Europe, from R&D to industrial application. Presentation of the FP6 European project BIOSHALE: Exploitation of black shale ores using Biotechnologies.

Various publications, conferences, posters, lectures were produced by Bioshale partners. They are listed hereafter in the partners contributions. The main figures concerning the Dissemination of knowledge of Bioshale project during the 39 months of the project are presented below.

Categories	Number
Participation to conferences	60
Number of conferences	15-20
Oral presentation	35
Poster presentation	27
Extended abstract / proceedings	25
Publications (under preparation)	34 15
Press release, internal company journals	14
Lecture, training material	10
TV	2 (in UK - BBC4 and Finland)
Flyer (general presentation of Bioshale project): translated in 5 European languages (UK, French, Polish, Finnish, Spanish and Welsh)	

The coordinator is keeping Bioshale WEB site updated (<http://bioshale.brgm.fr>). This web site will be kept updated for two years after the end of the project.

Bioshale Project - Main Figures

- Duration : 3 Year 3 months
- Total Budget : 3,561 M€

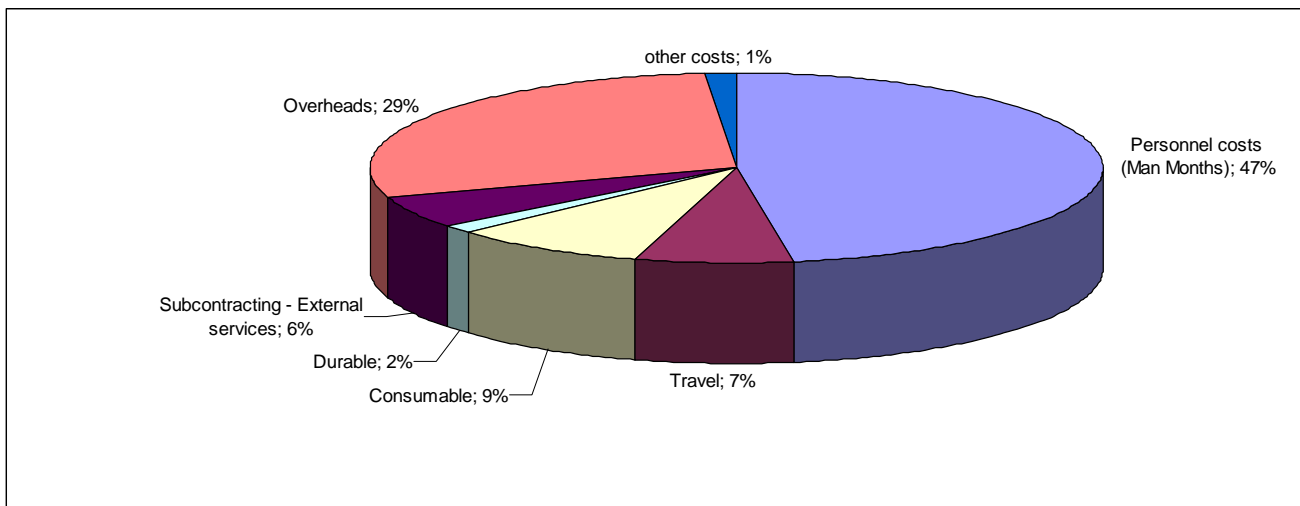

Overview of costs by cost categories (full duration)

- Number of working days on the project: > 10,000 - 12,000 days

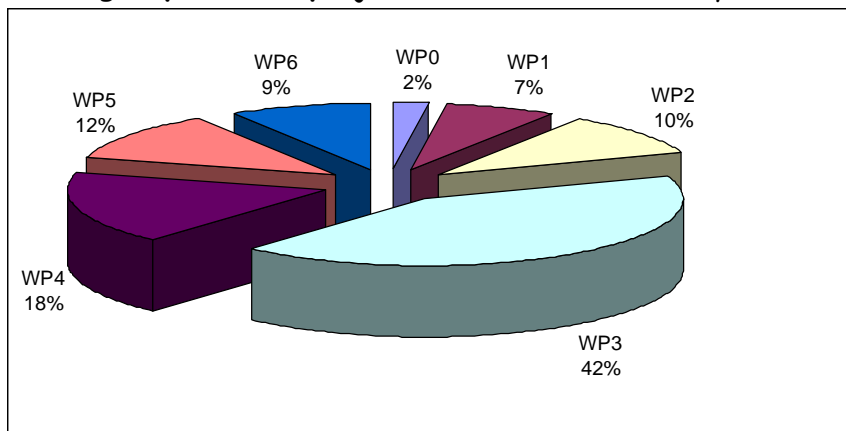

➤ Overview effort (MM) by WP vs. Total effort

- Direct Participants to the project : 100-120 over the 39 months
- pHD students directly involved on Bioshale project: 6
- Number of Students who worked for some time on Bioshale project: approximately 20 students.
- 12 Project Meetings (7 progress meeting + 5 workshops)
 - Orleans, Wroclaw, Freiberg, Helsinki/Talvivaara, Warsaw, Helsinki, Bangor, Lubin, Madrid, Paris, Sofia, Orleans

Partners Contributions



Partner name: **BRGM** - Partner number: 1

Author(s): **P. d'Hugues, P. Spolaore, C. Jouliau, T. Augé, J. Gouin, D. Morin**



1. Project execution

The 2 main objectives of BRGM were:

- (i) to coordinate the administrative, technical and scientific aspects of the consortium activities,
- (ii) to participate to the R&D activities dedicated to the characterisation of the black shales resources and to the bioprocess development.

• **The tasks carried out by BRGM during Bioshale project can be summarised as follows:**

- Coordination and Management of the consortium activities from an administrative, technical and scientific point of view.
- Participation in the review study on Black Shale deposit and the selection of the project mineral targets.
- Participation in the selection of the various hydrometallurgical process options applicable to black shale ores and to the mid-term assessment of new processing routes including preliminary technico-economic evaluation.
- Participation in the work carried out for the characterisation of the ore minerals and organic matter before and during bio-processes.
- Participation in the screening and the selection of the bacterial consortia for bioprocess scale-up. Realisation of a pilot scale continuous bioleaching operation on a polymetallic concentrate (originating from Poland), targeting the extraction of both Cu and Ag.
- Determination of optimal operating conditions, metal dissolution kinetics, mass balance and performance data for process simulation.
- Participation in the monitoring of a pre-industrial scale demonstration (In Finland) plant using heap bioleaching technology for Ni, Zn and Cu recovery. Microbial ecology of the heaps using Molecular Biology tools. Modelling and simulation of heat transfer within the heap.

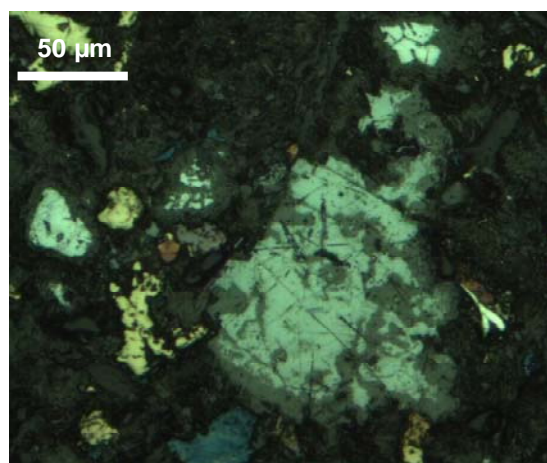

BRGM bioleaching laboratory-scale unit - Mineralogical characterisation of a Cu-sulphides grain contained in a bioleached residue.

- **Current relation of your work to the state-of-the-art**

The work carried out at BRGM on the Polish copper concentrate has the following general scientific and technical impacts:

- Contribution to the development of bioleaching technologies that can be applied for copper recovery in poly-metallic and poly-mineral concentrates.
- Optimisation of the recovery of silver from residues after bioleaching.
- Demonstration of the ability to bioleach metals from black shale type of ores that contain organic matter.

In the field of Bioleaching / Biomining, this work is of crucial importance for enlarging the potential technical options (beside the classical ones) that can be offered to the mining sector facing new types and challenging resources such as black shales.

The work carried out on Talvivaara case has more prospective and academic objectives that can be summarised as follows:

- Investigation of the microbial ecology of heap leaching operation (using Molecular Biology tools).
- Modelling and simulation of heat transfer using "real" data from pilot operations.

In the field of Bioleaching / Biomining, this work is of crucial importance for designing and monitoring industrial heaps.

2. Dissemination and use

The Actions used for disseminating the knowledge & communicating on the project as presented hereafter.

- **Updating of the project WEB site (<http://bioshale.brgm.fr/>)**

- **Participation to various conferences - Papers in Proceedings**
- **Bioprocop 06, June 2006, Lubin, Poland** (Head quarter of KGHM Polska Miedź S.A.) (Oral presentation). Perspectives for applying bioleaching technology to process shale-bearing copper ores. P. d'Hugues and D. Morin.
- **BioHydromet 07, Falmouth, UK May 1-2, 2007 (Oral presentation)**
Bioshale FP6 European project: search for a sustainable way of exploiting black shale ores using biotechnologies. P. d'Hugues, P.R. Norris, K. Hallberg, F. Sánchez, J. Langwaldt, A. Grotowski, T. Chmielewski, S. Groudev and Bioshale consortium
- **IBS 2007 Frankfurt, Germany, 2-5 September 2007 (Oral presentation)**
The Bioshale project: search for a sustainable way of exploiting black shale ores using biotechnology. P. d'Hugues, A. Grotowski, A. Luszczkiewicz, Z. Sadowski, T. Farbiszewska, A. Sklodowska, K. Loukola-Ruskeeniemi, J. Langwaldt, J. Palma, P. Norris, F. Glombitza, S. Groudev, J. Pasava, and B. Johnson.
- **IBS 2007, Frankfurt, Germany, 2-5 September 2007 (Poster)**
Microbial populations in a 110 ton-scale column for the recovery of metals from black schist ores. K. B. Hallberg, D. B. Johnson, J. Langwaldt and C. Jouliau
- **XII International Conference of Mineral Processing, Szklarska Poreba, September 17-20, Poland, 2007 (Oral presentation).**
Biohydrometallurgy: An opportunity for Europe, from R&D to industrial application. Presentation of the FP6 European project BIOSHALE: Exploitation of black shale ores using Biotechnologies. P. d'Hugues, P.R. Norris, B. Johnson, A. Grotowski, T. Chmielewski, A. Luszczkiewicz, Z. Sadowski, A. Sklodowska, T. Farbiszewska and Bioshale consortium.
- **11ème Congrès de Génie des procédés, St Etienne, France. 9-11 octobre 2007 (Poster).**
Optimisation du suivi d'un procédé continu de biolixiviation. P. Spolaore, P. d'Hugues, M.V. Durance et D. Morin.

- **The Society for Geology Applied to Mineral Deposits, SGA 9th Biennial Meeting, Dublin, Ireland, August 2007 (Poster)**
Organic and mineral characteristics of Kupferschiefer ore, comparison with the copper concentrate from Lubin mine (Poland). Implication for bioleaching of the ore. J. Gouin, T. Augé, L. Bailly, P. D'Hugues, J.R. Disnar & D. Keravis.

- **Publications**

- **Bioshale FP6 European project: exploiting black shale ores using biotechnologies?**
P. d'Hugues, P.R. Norris, K. B. Hallberg, F. Sánchez, J. Langwaldt, A. Grotowski, T. Chmielewski, S. Groudev and Bioshale consortium. Accepted in Minerals Engineering

- **Advertisement/Press release**

- Publication of a general document (1 page) presenting Biohydrometallurgy in Europe, Bioshale project, together with BioMinE project in The Parliament Magazine, Issue 234, November 2006. "Biotechnological research enters European Mineral Industry".

- **Dissemination Actions Planned in 2008**

Even though the project will be finished from an administrative point of view, dissemination of the scientific result will be carried out in 2008.

A paper presenting BRGM R&D work on the "pilot scale" continuous operation was accepted for presentation in the 24th International Mineral Processing Congress (IMPC 2008) that will be held in China in September 24-28, 2008. "Continuous bioleaching of a polymetallic black shale concentrate using the stirred tank technology". P. Spolaore, C. Jouliau, J. Gouin, F. Sánchez, T. Augé, D. Morin and P. d'Hugues.

It is also planned to write scientific papers in order to present the main technical results obtained at BRGM during the project. The potential papers are the following:

- "*Continuous bioleaching of a polymetallic black shale concentrate using the stirred tank technology*". From P. Spolaore, P. d'Hugues, C. Jouliau, J. Gouin, T. Augé and D. Morin.
- "*Thermal signatures and numerical modelling of convective processes during heap bioleaching of the Talvivaara black schist ore*". From Laurent Guillou-Frottier (BRGM), Patrick d'Hugues (BRGM) and Marja Riekkola-Vanhanen (TVK).
- "*Mineralogical impact of bioleaching of the Talvivaara black shale ore*". J. Langwaldt (GTK), J. Gouin (BRGM), T. Augé (BRGM)

Beside the project, J. Gouin will defend his PhD (March 2008, Orléans University), entitled "Genesis and beneficiation of black shale ores based on the Kupferschiefer (Poland) and Talvivaara (Finland) examples", mainly based his contribution in the Bioshale project

Some of the results will be published as specific papers.

Partner name: KGHM Cuprum sp. z o.o. CBR Partner number: 2	
Author(s): Andrzej Grotowski	

Progress towards objectives - tasks worked on and achievements made with reference to planned objectives.

The works executed by Cuprum in the range of BIOSHALE project covered the broad scope of themes, including geology, selective mining methods (which could be potentially used for black shale selective mining), mineral processing and environmental protection.

They mainly concerned possibilities and limitations of the currently used processes for black shale copper ore exploitation with a special emphasis on KGHM Polish Copper S.A. operation. Additionally, were some universal models for application of bioleaching for exploitation of black shale in existing and new operation were also elaborated and discussed.

The general overview existing knowledge about KGHM Polish Copper deposit was made and shortened information was prepared for the Project partners. The description of deposits its geology, mineralization, thickness, resources, mining methods, used processing technology, concentrators, smelters, flotation tailing management, etc. was given.

The general geological characteristic of black shale copper ore deposit was presented and the special attention was paid to the specific aspects of deposit which could enable a future separation of shale, e.g. shale profile distribution, cross-sections distribution, chemical analysis results and mineralogical characteristics differentiation, etc..

The received geological information was used in next stage of Project for definition of guides for selection of an ore horizon at Lubin mine. Because of the geological conditions of deposit and small thickness of black shale strata, research team decided to treat the whole thickness of a black shale layer as a one ore horizon.

This basic information together with other data has enabled to elaborate methods for selective separation of shale from Lubin copper ore at mining stage. All variants of the possible to implement selective mining methods were presented in details in the reports. Among them one should mention the system of mechanical getting the deposit, combine (mechanical miner) system, system with diamond saw as well as adaptations of the existing methods of the selective and separate mining.

It was pointed out that final selection of a system for industrial tests should be preceded by establishing the profitability criteria of its selective management (saying "management" we understand the entire process of winning, transport and processing in concentrators). Economic calculation made in the continuous system first of all should define the costs and effects of shale separate processing in the concentrator and only on this basis define the shale ore mining methods in the aspect of local mining and geological conditions, especially thickness of shale. Possible technologies of mining the shale ore should be accommodated to the local mining and geological conditions even within the one mining panel.

If one assume that the cost of exploitation of this ore type (associated with or without others lithological types in deposit profile) is of secondary meaning, we could use existing, verified exploitation systems, e.g. J-UG-PS, J-Du, one-phase system with roof deflection or room and shortwall system. New systems like diamond wire could be applied for extracting only shale ore (upper and lower rocks leave underground). However this system does not work properly in KGHM Polish Copper Mines yet and needs a lot of further experimental works.

The result of this work enabled to conclude that currently a variant of using the processing methods instead of mining ones for black shale concentration appears as more justified.

The assessment of currently used concentration process was made basing on the long period operation of Lubin plant, with special attention drawn to organic carbon concentration. One should say that in spite of a relatively low enrichment ability of the black shale ore, a concentrate amounting to 17-18 % Cu is produced with recovery 87,2 % from the ore with content of approx. 1,1-1,3 % Cu, in a stable manner. However, the question of improving the quality of concentrate and/or recovery, still exists. The tests and comparative analysis with other black shale deposits enabled to determine and confirm that the most important reasons for low concentrability of black shales are organic carbon (Lubin and Mansfeld deposits) or graphite (Talvivaara).

The other reasons are: inconvenient ratio of floatable gangue to copper sulphides, in spite of quite high copper content in the feed (Mansfeld, Lubin); rather fine grain size distribution of sulphides (Lubin, Talvivaara, Mansfeld); occurrence of clays (Mansfeld and in some extent Lubin also). According to current the-state-of-the-art, flotation or concentration methods which can overcome above mentioned obstacles still do not exist, so the only method to make a real breakthrough in this area is using a knowledge-based technology of bioleaching, like BIOSHALE.

Basing on the detailed industrial audit of Lubin concentrator, behaviour of black shale in the flowsheet was determined, basing on chemical analysis, and grain size distribution results. There one can find products with very different content of organic carbon and copper from 1.07 do 11.47 % Corg and from 0.11 % do 16.19 % Cu total in the Lubin circuits:

6 different canonical models for implementation of bioleaching in the existing and new mines have been elaborated and analysed. 1 model concerns ore leaching and the rest of them - bioleaching of a product after some form of concentration. After analysis of Lubin case, concentrate bioleaching and also midlings bioleaching was selected as the most interesting variants. For concentrate bioleaching several simulations were carried out in order to check what is an influence of different copper prices, recovery and operating costs on the difference between annual operating technical costs and sales. The influence of prices is obvious: the higher price the better difference, however nobody can change prices. Recovery has of course positive influence on the difference but the most important are operating costs. It means that in next stage of research on bioleaching is necessary to look for ways for lowering operating costs. Analysing bioleaching results one can come to a conclusion that especially the research on shortening of retention time in reactors and elaboration of new construction of reactor with lower operating costs, should be started. Those simulations have a value only for strategic selection of further research directions because they do not take into account other operating costs like mining costs, dangerous waste storage costs, environmental costs, administration costs, etc. and additionally some of the used data are only approximation. Basing on the received results the possible variants of implementation of bioleaching to the existing production chain have been elaborated and analysed.

Environmental aspects were overviewed for mines, concentrators and smelters and depending on the production stage they have different significance. Underground mining of copper ore deposit is been carrying out in the boundaries of five mining areas (OG „Lubin I”, OG „Rudna I and II”, OG „Polkowice II”, OG „Sieroszowice I” and OG „Radwanice Wschód”), through three mines (ZG „Lubin”, ZG „Rudna”, ZG „Polkowice-Sieroszowice”), with 18 shaft yards, where are located 29 shafts with different function, including 11 upcast shafts. Mining area is localized in southern-western part of Poland and comprises surface area of 412 km², and with influence area determined by boundary of mining area - 462 km². Deposit underground mining and mining activity are sources of negative impacts on the individual environmental components, which have been described in details in the deliverable D1.3. Processing of ore is carried out in three concentrators „Lubin”, „Rudna” and ZG „Polkowice”, with total

capacity approx 30 mnl ton. As far as copper production goes, two technologies are used in KGHM Polska Miedź S.A. smelters: flash and shaft furnaces. Flotation tailings are stored in "Żelazny Most" Tailing Facility. The interesting feature of those tailings is that due to the presence of carbonate rocks they do not cause acid drainage, what practically always encountered in the case of tailings from porphyry copper ores. Operating the facility is made in the way, which guarantee meeting all being in force emission standards, contained in the relevant regulations. This situation concerns all objects operated by KGHM Polish Copper.

The above mentioned objects influence with different intensity on:

- underground water,
- surface water,
- soils and earth,
- acoustic climate

All those issues have been described, analysed and evaluated and the results can be found in the relevant reports.

The similar Environmental Impact Analysis was also carried out for the proposed process of Lubin concentrate bioleaching by BIOSHALE methods.

Environmental advantages and disadvantages of new method have been clearly show.

Dissemination and use

Publishable results of the Final plan for using and disseminating the knowledge.

Publishable results	Exploitable product(s) or measure(s)	Sector(s) of application	Owner & Other Partner(s) involved*
<i>Knowledge about environmental impacts of the current standard way of copper production and future bioleaching method application</i>	<i>Report</i>	<i>Mineral processing Geology- exploration</i>	<i>Cuprum/ KGHM Polska Miedź Bioshale consortium</i>
<i>Guides for choosing mining methods for selective exploitation of black shales</i>	<i>Report</i>	<i>Mining, geology- exploration</i>	<i>Cuprum/ KGHM Polska Miedź Bioshale consortium</i>
<i>Knowledge about black shale behaviour in flotation circuits of commercial concentrators</i>	<i>Raport</i>	<i>Processing, Geology- exploration</i>	<i>Cuprum/ KGHM Polska Miedź Bioshale consortium</i>

* according to inputs

Partner name: PWR (Wroclaw University) Partner number: 3	
Author(s): Tomasz Chmielewski, Andrzej Luszczykiewicz, Zygmunt Sadowski	

1. Project execution

It is well known, that mineralogical and chemical composition of Polish copper shale ores is very unique and simultaneously very favourable for hydrometallurgical and bio-metallurgical processing. Predominant content of chalcocite and bornite, the easiest leachable copper sulphides, and fine dissemination of metal-bearing minerals in carbonate and organic matter makes the suggested treatment with sulphuric acid solutions most rational from technical, economical and ecological points of view.

High content of carbonate host minerals (dolomite) requires the application of non-oxidative leaching with sulphuric acid for carbonate decomposition and for liberation of sulphide minerals prior to the oxidative leaching in atmospheric or in pressure conditions. This "chemical milling" process utilises chemical reaction energy for liberation and particle size reduction. Significant lowering of the redox potential in the leaching slurry as a result of carbon dioxide formation ensures process selectivity and prevents the leaching of metals from their sulphides. Non-oxidative leaching is very rapid process (about 60 minutes) and can be conducted in simple reactors with stirring. It must always be performed if Lubin shale middlings are the feed for acidic hydrometallurgical or bio-metallurgical processing.

Atmospheric leaching of Lubin shale middlings with oxygenated sulphuric acid with addition of Fe(III), performed at temperature up to 90°C in two independent sampling campaigns, clearly shown that the process can be effectively applied for examined shale feed, due to the favourable mineralogical composition. This is generally in accordance with a tendency currently observed in world hydrometallurgy in selection of leaching systems for copper sulphide ores and concentrates. The effect of temperature, sulphuric acid concentration, Fe(III) concentration and reaction time were widely examined. The process is particularly useful for low grade sulphidic feed such as Lubin middlings for recovering of Cu, Co, Zn and Ni.

Pressure acidic oxidative leaching is at the present time effectively introduced to the industrial scale in several copper plants (Morrencia, USA; Sepon, Laos). This modern method of processing can also be recommended as a very rapid and efficient process for Lubin shale middlings. The effect of temperature (100 - 180°C), sulphuric acid concentration (20 - 50 g/l), oxygen partial pressure (2.5 - 10 atm) and reaction time (up to 210 minutes) were comprehensively examined. The process is predominantly useful for higher grade feed. We have found that upgrading of Lubin middlings by froth flotation can be accomplished if flotation feed was preleached using sulphuric acid.

As an alternative to acidic leaching ammonia pressure leaching was additionally examined for Lubin shale middlings. The process appeared to be very effective, leading to rapid digestion of all metals forming stable and soluble ammonia complexes (Cu, Ni, Co, Ag, Zn). Investigated were: temperature (120-180 oC), reaction time (up to 180 minutes, mixing rate (200 - 500 rpm) ammonia concentration (1.5 - 3.0 M), ammonium sulphate concentration (25 - 100 g/l), and oxygen pressure (5.0 - 12.5 atm). In terms of the technical criteria the process appeared to be very effective.

Pregnant leach solutions (PLS) were used for metals separation by means of solvent extraction preliminary investigations. The solvent extraction technique is one of the most versatile methods used for the removal, separation and concentration of metallic species from aqueous media. Our results on solvent extraction of metals from pregnant leach solutions after atmospheric leaching of shale middlings demonstrated, that application of aromatic hydroxyoximes for copper(II) extraction can give satisfying results. However, these extractants were not enough selective and other metal ion species present in leach solutions were also transferred to the organic phase. Furthermore the extractive recovery of

Cu(II), Co(II) and Ni(II) was better for the solutions obtained from acidic leaching of shale in the absence of Fe(III) salts.

Samples of solid residue after non-oxidative, atmospheric and pressure leaching were systematically investigated in terms of mineralogical composition and liberation of metal-bearing particles. It was found that unleached minerals remain predominantly in the organic shale fraction, which can not be decomposed during atmospheric or even pressure leaching. Particle size and microscopy SEM analyzes indicated that feed for oxidative leaching requires significant size reduction for liberation unleached particles disseminated in shale matter.

Deep technological analysis of Lubin Concentrator circuits and flotation parameters indicates that remarkable alterations in processing of shale fraction have to immediately introduced to avoid hardly to accept metal losses. High and still growing quantity of shale fraction in Polish copper deposits became the main reason of technological problems which can be avoided only when alternative methods of metals recovering will be accepted and introduced to the industrial scale.

The lithological formation called Kupferchiefer (black shale) contains the richest portion of noble, and base metal compares to the other parts of copper ore. The majority of valuable metals occurring in the form of metallorganic compounds. The main group of metallorganic compounds is metalloporphyrins. This fact creates the idea of biodegradation of these compounds.

Microbial degradation of both synthetic and extracted from black shale samples metalloporphyrines was investigated. Single strains and consortiums of heterotrophic microorganisms, isolated from flotation waste deposits (Zelazny Most, Gilow and Mansfeld) and purchased from ACC collection were used for biodegradation. The bacteria capacity for biodegradation was expressed by the metal ions and carbon concentration. Obtained data demonstrate that copper and cobalt porphyrines are easier biodegraded than nickel one.

Parallel to biodegradation of synthetic metallorganic compounds the process of biodestruction of extracted organic matter was conducted. The extraction of organic matter was carried out from different black shale samples, such as: mineralogical samples from Polkowice mine, middlings from Lubin mine and from Mansfeld heaps. It was showed that both an acid pretreatment and microwave irradiation improved the organic matter extraction. Bituminite is a typical amorphous organic matter widespread in black shale ore (from 41 up to 85 vol. %). Bituminite is difficult to biodegradation. Our investigations showed that metallorganic compounds and bituminite are more resistance to biodegradation and microorganisms needed a long period of time for this process.

The complete biodegradation of organic matter need a long period of time, however the heterotrophic biopretreatment should be improve both sulfides flotation and acid bioleaching. In order to verify this hypothesis the two-stages bioleaching process was investigated. Two-stage bioleaching process was carried out with middlings from Lubin mine. 15 days heterotrophic treatment was used. The bacteria consortium and *Streptomyces setoni* were used. The obtained result showed that the two-stage bioleaching process was more effective then an acid bioleaching. The copper recovery was at the vicinity 90%.

Some bacteria and fungi can significantly promote flotation of minerals. The modification of sulfide minerals by heterotrophic microorganisms was tested including carrying out the 14 days biotreatments of middlings. However, the flotation results have been unsatisfied.

Heap bioleaching is an important extraction process used in the removal of metal from low grade ores. This bioleaching process involves the infiltration of leaching solution and injection of air into the heap. The particle size distribution plays an important role for the heap preparation. It has been showed that the average particle size of middlings was 45.3 μ m and 85% of particles have a size smaller then 100 μ m. For this reason, the filler materials such as plastic lumps and sawdust were used. Data from small column tests showed that the middlings bioleaching kinetics were favoured at the presence of fillers.

Fundamental for complete design of the process is investigation of model. The mathematical model of bioleaching is useful in studying the relationships between the factors influencing the bioleaching process

and bioleaching results. According to our work, the copper recovery of bioleaching process is correlated to the specific surface area changes.

2. Dissemination and use

Results of non-oxidative, atmospheric and pressure leaching (both in acidic and in ammonia solutions) are being disseminated mainly in the form of publications in international journals or presented in international conferences.

Taking into account the great meaning of investigated processes for technological modification of processing circuits of Polish copper ores, particularly at Lubin Concentrator, we would like to commence up scaling investigations for application of obtained results in industrial scale in order to enhance the recovering of metals at Lubin plant.

- Results of metalloporphyrines and organic matter biodegradation were presented IBS -2007,
- Two-stage bioleaching process and mathematical model of bioleaching were presented at Bio- & Hydrometallurgy 07, Falmouth, UK

BIOSHALE - PWR LIST OF PUBLICATIONS

1. **Chmielewski T., Charewicz W.**, Hydrometallurgical treatment of shale middlings from Lubin Concentrator, *BIOPROCOB*, Lubin 19. June 2006, (Antoniuk A., ed.), KGHM Cuprum, Wrocław 2006, 125-145.
2. **Groudev S., Spasova I., Nicolova M., Chmielewski T., Łuszczkiewicz A.**, Recovery of copper by flotation of microcially pretreated black shales, *Proceedings: Bio- and Hydrometallurgy'07, Falmouth, UK, 1-2 May 2007 (published in the form of CD)*.
3. **Chmielewski T., Łuszczkiewicz A., Konopacka Ż.**, Separation and concept of processing of black shale copper ore from Lubin Mine, *7th International Conference on Non-ferrous Ore Processing, May 21-23, Wojcieszycze, Poland, KGHM Cuprum, Wrocław 2007, 171-184*.
4. **T. Chmielewski**, Non-oxidative leaching of black shale copper ore from Lubin Mine, *Physicochemical Problems of Mineral Processing, 41 (2007) 323-348*.
5. **Chmielewski T.**, Atmospheric leaching of shale by-product from Lubin concentrator, *Physicochemical Problems of Mineral Processing, 41 (2007) 337-348*. **Konopacka Żaklina, Łuszczkiewicz Andrzej, Chmielewski Tomasz**: Effect of non-oxidative leaching on flotation efficiency of Lubin Concentrator Middlings. *Physicochem. Probl. Miner. Process. 41 (2007) 275-289*.
6. **Konopacka Żaklina, Łuszczkiewicz Andrzej, Chmielewski Tomasz**: Effect of non-oxidative leaching on flotation efficiency of Lubin Concentrator Middlings. *Physicochem. Probl. Miner. Process. 41 (2007) 275-289*.
7. **Wódka J., Chmielewski T., Ziótkowski B.**, Pressure leaching of shale ore in oxygenated sulphuric acid, *Physicochemical Problems of Mineral Processing, 41 (2007) 349-364*.
8. **Rotuska K., Chmielewski T.**, Solvent extraction of valuable metals from pregnant leach solutions of cupriferous shale, *Physicochemical Problems of Mineral Processing, 41 (2007) 365-372*.
9. **d'Hugues P., Norris P.R., Johnson B., Grotowski A., Chmielewski T., Łuszczkiewicz A., Sadowski Z., Skłodowska A., Farbiszewska T.**, Presentation of the FP6 European Project Bioshale. Exploitation of black shale ores using biotechnologies - Polish case studies, *Physicochemical Problems of Mineral Processing, 41 (2007) 373-386*.

10. d'Hugues P., Norris P.R., Johnson B., Grotowski A., Chmielewski T., Łuszczkiewicz A., Sadowski Z., Skłodowska A., Farbiszewska T., Presentation of the FP6 European Project Bioshale. Exploitation of black shale ores using biotechnologies - Polish case studies, *Physicochemical Problems of Mineral Processing*, 41 (2007) 373-386.
11. Chmielewski T., Luszczkiewicz A. and Konopacka Z., Acidic pretreatment of hard-to-tread copper ore flotation middlings to facilitate flotation efficiency, *XXIV Int. Mineral Processing Congress (IMPC 2008), China 24-28 Sept., 2008 (accepted for publication)*.
12. Chmielewski T., Luszczkiewicz A., Hydrometallurgy of shale middlings from Lubin Concentrator - a need for technological alterations, *International Conference on: Accompanying metals in non-ferrous metallurgy, 9-11 April, 2008 (accepted for publication)*.
13. Wódka J., Chmielewski T., Pressure leaching of shale middlings -for recovering of copper and accompanying metals, *International Conference on: Accompanying metals in non-ferrous metallurgy, 9-11 April, 2008 (accepted for publication)*.
14. Farbiszewska T., Farbiszewska-Kiczma J., Jazdzyk E., Sadowski Z., Szubert A., Kinetic study of biodegradation of organic matter extracted from black shale ore, *Physicochemical Problems of Mineral Processing*, 40, 2006, 317-325.
15. Szubert A., Łupiński M., Sadowski Z., Application of shrinking core model to bioleaching of black shale particles, *Physicochemical Problems of Mineral Processing*, 40, 2006, 211-225.
16. Jazdzyk E., Szubert A., Sadowski Z., Możliwości wykorzystania bioprocessów w przemyśle metalurgicznym, *BIOPROCOP'06, Lubin 19. June 2006, (Antoniuk A., ed.), KGHM Cuprum, Wrocław 2006, 49-64*.
17. Jazdzyk E., Szubert A., Sadowski Z., Bioleaching of black shale ore from Lubin, 10th Conference on Environment and Mineral Processing, 22-24 June 2006 VSB-TU Ostrava Czech Republic.
18. Szubert A., Lupinski M., Sadowski Z., A kinetics of black shale-type ores bioleaching in column, *Proceedings: Bio- and Hydrometallurgy'07, Falmouth, UK, 1-2 May 2007 (published in the form of CD)*.
19. Jazdzyk E., Sadowski Z., Szubert A., Heterotrophic and autotrophic bioleaching of middlings from flotation of Lubin mine, *Proceedings: Bio- and Hydrometallurgy'07, Falmouth, UK, 1-2 May 2007 (published in the form of CD)*.
20. Sadowski Z., Szubert A., Maliszewska I., Jazdzyk E., A view on the organic matter and metaloporfiryn biodegradation as characteristic components of black shale ores, *17th International Biohydrometallurgy Symposium, Frankfurt am Main, Germany 2-5 September 2007. Advanced Materials Research, 20-21*.
21. d'Hugues P., Grotowski A., Łuszczkiewicz A., Sadowski Z., Farbiszewska T., Skłodowska A., Loukola-Ruskeeniemi K., Langwaldt J., Palma J., Norris P., Glombitza F., Grudev S., Pasava J., Johnson B., The Bioshale project: search for a sustainable way of exploiting black shale ores using biotechnology, , *17th International Biohydrometallurgy Symposium, Frankfurt am Main, Germany 2-5 September 2007*.
22. Sadowski Z., Szubert A., Comparison of kinetics of black shale bioleaching processing using stationary and agitated systems, *Physicochemical Problems of Mineral Processing*, 41, 2007, 387-395.
23. Luszczkiewicz A., Konopacka Z., Drzymala J., Flotation of black shale of Polish copper ore from Lubin., *Proceedings: Perspectives for applying bioleaching technology to process shale-bearing copper ores, BIOPROCOP '06, Lubin, June 19, 2006, (Antoniuk A., ed.) KGHM Cuprum Sp. z O.O., Wrocław 2006, 29-47*

Partner name: University of Opole (UO) Partner number: 4	
Author(s): Teresa Farbiszewska, Jadwiga Farbiszewska-Kiczma, Tomasz Grobelski	

The Bioshale project, involving 13 partners throughout Europe, is a European project under the FP6 program. Started in October 2004, this project is focused on identification and developing innovative biotechnological processes for sustainable exploitation of metalliferous black shale ores.

The R&D actions cover three important deposits: (1) Talvivaara, Finland (not exploited before 2004); (2) Lubin, Poland (currently mined); and (3) Mansfeld, Germany (already mined out). The black shale ores contain base (as copper and nickel), precious (silver) and platinum group metals, as well as high contents of organic matter that possibly make conventional techniques of metal recovery insufficient.

The UO's research under Bioshale project was focused on bioleaching of Polish black shale ores (Lubin middlings and Polkowice concentrate) and Talvivaara ore, including collection, inventory and screening of microorganisms collected on mining sites at Lubin (Poland), Talvivaara (Finland), Mansfeld (Germany) and Bangor (Wales).

Heterotrophic and autotrophic cultures were isolated:

1. Talvivaara: 37 heterotrophic, 6 autotrophic;
2. Lubin: 49 heterotrophic, 25 autotrophic;
3. Mansfeld: 17 heterotrophic, 3 autotrophic;
4. Bangor: 6 heterotrophic, 6 autotrophic.

The most efficient cultures were selected for further bioleaching purpose.

First bioleaching test of all three materials was performed in laboratory scale in 350 cm³ shake flasks using pure and mixed autotrophic and autochthonic cultures of *At. ferrooxidans* and *At. thiooxidans* at low pH (=2) and temperature 4, 25 and 40 deg (Lubin case) or 25 deg. (Polkowice and Talvivaara case). This preliminary test confirmed all three materials being amenable to bioleaching.

Next test performed in shake flasks was two-stage process that combined initial processing at neutral pH (=7) using pure and mixed heterotrophic cultures prior to acidic bioleaching at low pH (=2). Although heterotrophic bioleaching efficiency was found poor, experiments showed that an initial processing at neutral pH resulted in an increase in metals recovered by bioleaching at acidic pH using autotrophic cultures.

Although it was found that initial neutral processing strongly improved rate and efficiency of further acidic bioleaching, the origin of this phenomena is still unclear. It seems that it resulted from either greater degradation of black shale organic fraction and expansion of surface area of material particles.

Following these preliminary tests, two-stage process was slightly up scaled and modified by using 2 dm³ tank bioreactors with barbotage system with the same cultures of bacteria and pH values and temperature.

The last step of research was column test. The amount of material used in column test was 4 times greater than in tank bioreactor and 20 times greater than in shake flask. The solid to liquid ratio was 1:2. Two types of columns were tested: with one and five beds; both equipped with barbotage system.

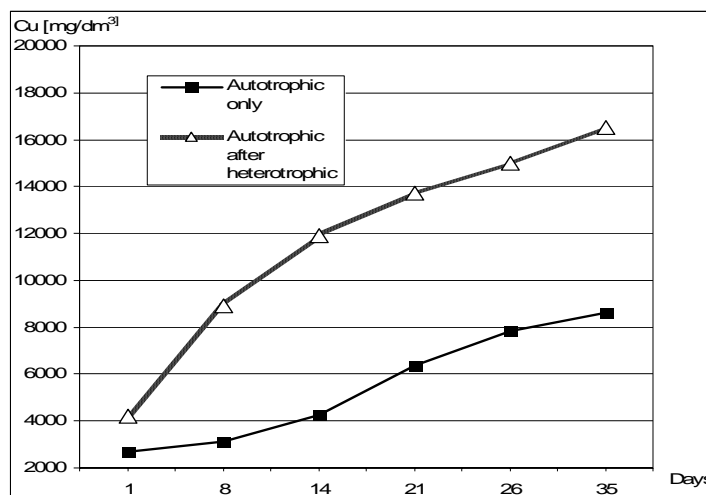

Fig. 1. Comparison of Cu extraction kinetics in autotrophic and two stage bioleaching in tank cultures for Polkowice concentrate.

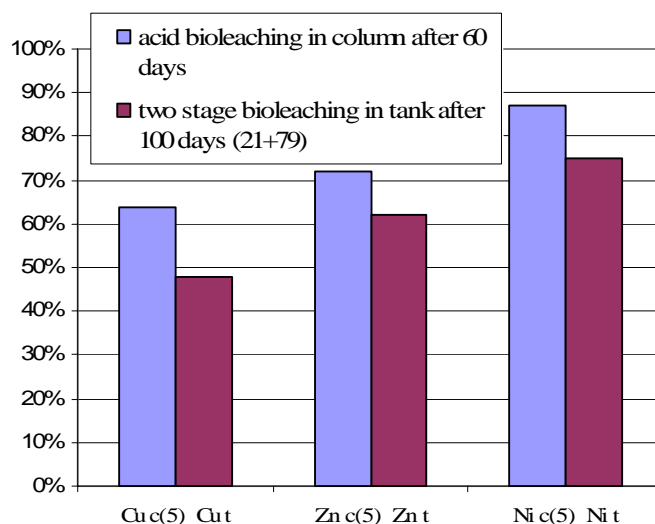

Fig. 2. Comparison of Cu, Zn, Ni extraction levels in column (five beds) and tank cultures for Talvivaara ore.

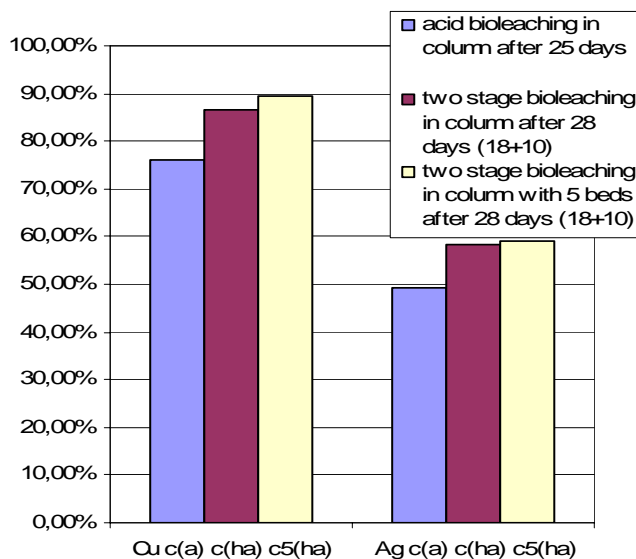

Fig. 3. Comparison of Cu and Ag extraction levels of acid and two stage bioleaching in column cultures for Polkowice concentrate.

All the research tests involved batch and column tests using various cultures of bacteria and different amounts of materials and solid vs. liquid concentrations (1:5 for shake flasks, 1:3 for tank bioreactors, 1:2 for columns). Two-stage process consists of initial neutral processing and further acidic bioleaching was introduced as very promising processing manner. Since the results of columns experiments seemed to be most valuable, it might be recommended to continue research work using columns, particularly columns cascades.

Two-step bioleaching positive impact on metal recovery efficiency in case of Lubin and Polkowice material still remains to be demonstrated. Up scaled tests are required. So far it seems that initial neutral processing combined with acidic bioleaching might be useful especially for processing of black shale enriched with rare and noble metals enclosed in the organic fraction.

References

- Farbiszewska-Kiczma J., Farbiszewska T.: Isolation of bacteria that degrade organometallic compounds from metallic wastes, *Physicochemical Problems of Mineral Processing*, z. 39, Wrocław 2005, str. 263-267, ISSN 0137-1282
- Farbiszewska-Kiczma J., Farbiszewska T.: Isolation of bacteria that degrade organometallic compounds from metallic wastes, *XLII Seminarium Fizykochemiczne Problemy Mineralurgii, Wiśła-Malinka*, 5-7 września 2005
- Farbiszewska-Kiczma J., Farbiszewska T., Bąk M.: Bioługowanie związków metaloorganicznych z odpadu po kwaśnym bioługowaniu rudy miedzi, *XXIII Międzynarodowa Konferencja Naukowa „Inżynieria procesowa w ochronie środowiska”*, Opole - Polanica Zdr., 18-20 maja 2005
- Farbiszewska T., Farbiszewska-Kiczma J., Jażdżyk E., Sadowski Z., Szubert A.: Kinetic study of biodegradation of organic matter extracted from black shale ore, *XLIII Seminarium Fizykochemiczne Problemy Mineralurgii, Zakopane*, 18-20 września 2006
- Farbiszewska T., Farbiszewska-Kiczma J., Jażdżyk E., Sadowski Z., Szubert A.: Kinetic study of biodegradation of organic matter extracted from black shale ore, *Physicochemical Problems of Mineral Processing*, z. 40, Wrocław 2006, str. 317-325, ISSN 0137-1282
- Farbiszewska-Kiczma J., Farbiszewska T.: Bioleaching tailings after concentration of polish copper-bearing ores, conference proceedings - „Perspectives for applying bioleaching technology to process shale-bearing copper ores”, *BIOPROCOP'06, Lubin* 19.06.2006
- Farbiszewska-Kiczma J., Farbiszewska T.: Bioleaching tailings after concentration of polish copper-bearing ores, *Conference BIOPROCOP'06, Lubin* 19.06.2006, s. 107-125
- Farbiszewska T., Farbiszewska-Kiczma J., Grobelski T.: Bioleaching of Talvivaara ore in neutral and acid medium, *17th International Biohydrometallurgy Symposium, Frankfurt am Main*, 2-5 September 2007
- Grobelski T., Farbiszewska-Kiczma J., Farbiszewska T.: Bioleaching of Polish Black Shale, *XLI Seminarium Fizykochemiczne Problemy Mineralurgii, Szklarska Poręba* 17-20.09.2007r.
- Grobelski T., Farbiszewska-Kiczma J., Farbiszewska T.: Bioleaching of Polish Black Shale, *Physicochemical Problems of Mineral Processing*, z. 41, Wrocław 2007, str. 259-264, ISSN 0137-1282
- Farbiszewska T., Farbiszewska-Kiczma J., Grobelski T.: Bioleaching of black shale Talvivaara ore, *Ecological Chemistry and Engineering*, 2007.

Partner name: Warsaw University, Faculty of Biology Partner number: 5	
Author(s): Aleksandra Sklodowska, Renata Matlakowska, Bartosz Rewerski	

1. Project execution

1.1. Bioleaching of metals from copper bearing black shale ore in neutral and acidic conditions

The highest bioleaching efficiency (more than 70% in 14 days) was reached in the case of *A. ferrooxidans* SS in the process with preacidification in relation to copper and cobalt opposite to arsenic. Arsenic was leached with the highest efficiency in culture of *A. ferrooxidans* SS with pH regulation but without preliminary acidification.

In neutral pH copper was leached in 11,95% in the case of mixed culture, 1,45% in control 0% in *Marinobacter* sp. culture. Cobalt was leached respectively 15,81%, 11,64% and 1,69%. Arsenic was leached rather in chemical way, however the result obtained for *Marinobacter* sp. is strange.

The significance of indigenous strains for biotechnology of metal leaching seems to be negligible but obtained results are important for environmental aspects.

1.2. The analysis of the microbial population of Lubin copper mine and the role of indigenous bacteria in biotransformation of black shale ore.

Nine strains were isolated from copper bearing black shale ore. Phylogenetic analysis showed that four strains belonged to γ -Proteobacteria (*Pseudomonas*), one to Firmicutes (*Bacillus*) and three to Actinobacteria (*Microbacterium* sp., *Microbacterium oxydans*, *Acinetobacter junii*). One isolate was identified as the yeast *Rhodotorula mucilaginosa*.

The indigenous bacteria exhibited a broad range of interesting physiological properties related to geochemical parameters of the examined environment. First of all all isolates were characterized by high multiresistance to different elements, including copper and arsenic. All isolates possessed esterase and lipase activities. Some of them were able to assimilate organic acids. One of the isolates (*Pseudomonas* sp.) possessed the activity of dioxygenase and was able to degrade phenanthrene. All indigenous bacteria were positive for heme lysis. All strains of *Pseudomonas* sp., *A. junii* and *R. mucilaginosa* were able to degrade synthetic metalloporphyrins. The role of indigenous microorganisms in biodegradation of black shale was also confirmed. It was accompanied by the release of metals. The changes of vanadium concentration were correlated with the DOC concentration. Additionally all **microorganisms** isolated from Lubin copper mine showed the presence of siderophores during growth on medium without free iron ions. The presence of siderophores is significant because it leads to the mobilization of ferric ions from insoluble compounds and confirm the potential role of microorganisms in metal dissolution.

Four of tested *Pseudomonas* strains isolated from black shale ore exhibited huge resistance to inorganic arsenic species [As (III) and As (V)]. The tolerance to arsenate and arsenite was even up to 500mM (37500ppm) and 15mM (225ppm), respectively. Preliminary results showed that *Pseudomonas* strains evolved strong resistant mechanism supported by arsenate reduction but none of tested bacteria could utilize arsenite or arsenate in respiratory processes. This activity of described isolated bacteria may lead to mobilisation of more toxic arsenic species [As (III)] to the environment.

Taking into account the chemical composition of black shale ore and physiological characteristics of isolates it can be assumed that indigenous bacteria are well adapted to this extreme environment. In the black shale ore metals occur in the form of sulfides as well as metalloorganic compounds such as porphyrins and sandwich compounds in which they create organometallic connections with hydrocarbons. The ability of indigenous microorganisms to degrade porphyrins and bituminous shale and use them as carbon source, as well as other physiological properties, suggests they may play a role in biogeochemical

cycles of metals occurring in the organic fraction of black shale ore as well as in the weathering of this ore. This phenomenon should be taken into account in long term environmental risk assessment.

3.1. Long term environmental risk assessment

Global environmental impact evaluation of present black shale deposits during and after mining activities was prepared for the area after mining (Mansfeld), during mining (KGHM Polska Miedź) and before mining (Taalivara). Evaluation of the effect of new technologies to the environmental stress of black shale mining was estimated for Taalivara and KGHMPolska Miedź. Recommendations for (a) environmental protection during mining and (b) remediation after mining for each of the technologies were presented as an output from WP1-WP5, using EMAS, Directives 85/337/EEC and Directive 97/11/EC - on the assessment of the effects of certain public and private projects on the environment and analysis of compatibility with other EU Directives (eg. IPPC, waste policy Directive No99/31/EC, etc.). In summary (see Annex to Deliverable 6.4) for Global environmental impact evaluation the scale prepared by GTK represented by Jorg Langwald was used. The comparison of all studied cases clearly showed the largest environmental impact of residue after mining processes in Mansfeld and KGHMPolska Miedź, which use classic method of metallurgy. The environmental impact may be decreased in 50% with the use of new biotechnology in case of KGHMPolska Miedź. In case of Taalivara the environmental impact is disadvantageous in case of implementation of new technology and the lowest impact should be noted when the heap leaching is applied.

2. Dissemination and use

- **Matlakowska R., Hallberg KB., Skłodowska A., 2007, Isolation and characterisation of microorganisms from copper bearing black shale of Lubin copper mine (Poland), Advanced Material Research, vol. 20-21, 580-580**
- **Matlakowska R., Skłodowska A., 2007, Biodegradation of organic matter and release of heavy metals from the copper bearing black shale of Fore Sudetic Monocline (Poland), Advanced Material Research, vol. 20-21, 238-239**
- **International Symposium of Environmental Biogeochemistry 2007, New Zealand:**
- **Matlakowska R., Drewniak L., Skłodowska A. Arsenic hypertolerant *Pseudomonads* isolated from ancient gold mine and copper bearing black shale ore.**
- **International Conference on non-ferrous ore processing, 2007, Poland:**
- **Matlakowska R., Biernat A., Skłodowska A., Organic and metalloorganic compounds in Polish copper bearing black shale- possibilities for bioleaching of rare-earth elements. P. 167-170**
- **International Biohydrometallurgy Symposium 2007, Germany:**
- **Matlakowska R., Hallberg KB., Skłodowska A., 2007, Isolation and characterisation of microorganisms from copper bearing black shale of Lubin copper mine (Poland), Advanced Material Research, vol. 20-21, 580-580**
- **Matlakowska R., Skłodowska A., 2007, Biodegradation of organic matter and release of heavy metals from the copper bearing black shale of Fore Sudetic Monocline (Poland), Advanced Material Research, vol. 20-21, 238-239**
- **Perspective for applying bioleaching technology to process shale-bearing copper ores 2006, Poland:**
- **Skłodowska A., Copper industry more environmental friendly? P.147-158**

Partner name: GTK Partner number: 6	
Author(s): Jörg Langwaldt	

The Geological Survey of Finland GTK performed its major RTD actions within the Bioshale project at GTK's Mineral Processing Laboratory in Outokumpu, while GTK's Southern Finland Office contributed to a minor extent. The Mineral Processing laboratory and research group is dedicated to size reduction and processing different kinds of ores and raw materials in close cooperation with companies, universities and other research institutes. The mission is to improve the results of different unit operations and the competitiveness of the clients. The mineral processing laboratory and pilot plant facilities, in the scale and variety GTK has them, are rare in the world. A full study including mineralogical work, bench scale tests and a pilot campaign can be undertaken in the premises for the client's ore evaluation projects. The capacity of the pilot plant (from 0,5 up to 5 t/h) fulfills the requirements of testing the workability of the complete continuous beneficiation process.

GTK utilized the largest human (about 90 person-months) and financial resources (835 000 euro) of all partners in the Bioshale project. GTK participated in all six work packages (WP) of the Bioshale project and contributed to 16 out of a total of 22 deliverables. GTK researchers were leader of the workpackages 1 and 6, and four deliverables. GTK was a member of the project steering group. Within the Bioshale project, GTK focused its resources on the process development for the Finnish Talvivaara black shale ore deposit.

The Talvivaara black shale deposit is one of the largest known nickel sulphide deposits in Europe and belongs to the Talvivaara Mining Company Ltd. The deposits comprise two different polymetallic orebodies: Kuusilampi and Kolmisoppi. The deposits situated in Sotkamo, Eastern Finland, belong to the Kainuu schist belt. The mineral resources have been classified by Australian JORC code at 337 million tonnes of ore, containing 0.26% of nickel, 0.55% of zinc, 0.14% of copper and 0.02% of cobalt. Deposition of metals took place originally about 2 billion years ago in organic-rich marine sediments. Organic carbon was converted to graphite during metamorphism. On average carbon and sulphur contents are 7.5% and 9.0%, respectively. The resources are well suited for open-pit mining, partly due to the thin overburden. On average, the thickness of overburden is estimated at 2 metres. Furthermore, the average barren rock to ore ratio is only 1.5/1, which enables cost-effective exploitation of the resource. So far, low grade and complex mineralogy of the nickel sulphide phases have been a major restraint for the exploitation. The principal iron sulphides in the Talvivaara black shales are pyrite (8%) and pyrrhotite (20%), the latter carrying about 1/3 of all nickel in the deposit. Other main host minerals of nickel are violarite and pentlandite being less abundant, but carry 66% of nickel. Chalcopyrite, sphalerite and alabandite are the main carriers of Cu, Zn and Mn, respectively.

In WP1, GTK supported the characterization of the Finnish Talvivaara black shale ore, the sampling of bioleaching microorganisms from the Talvivaara deposit and contributed to the assessment of the environmental impact of the un-exploited Talvivaara deposit. The evaluation of environmental impacts under natural conditions indicated that a major acidification and heavy metal release event took place in association with the drainage of the Sotkamo ice-lake 9000 years ago. The bottom section of peat profiles at the Ni-source, being accumulated soon after the retreat of the ice sheet, have the highest Ni and Zn concentrations. Peat accumulation has continued since drainage of the Sotkamo ice-lake. Evidently, acidic water is the transport medium carrying metals from the bedrock to peat and other soil formations and biosphere. The abundant peatlands with associated slightly acid waters may contribute in the groundwater recharge process by maintaining conditions favourable for elevated metal concentrations.

However, generally groundwater heavy metal concentrations are below the recommended guide values for drinking water in Finland.

The main objective of the Bioshale project is to define new biotechnological processes that are economically viable and environmentally friendly, for extraction of valuable metals from black shale ores. Two processing routes were defined for the Talvivaara black shale ore 1) heap bioleaching of agglomerated ore, and 2) (bio)flotation and stirred tank bioleaching of flotation concentrate.

In WP2, GTK carried out extensive work on the processing of a 200 ton black shale sample from the Talvivaara Kuusilampi orebody with kind permission of Talvivaara Mining Company Ltd., the deposit owner. The action included crushing, grinding and beneficiation tests. The latter, were focused on magnetic separation and flotation to produce a bulk sulphide concentrate for subsequent bioleaching tests in stirred tank reactors. The challenges for beneficiation were caused by the specific mineralogy of the Talvivaara black shale ore. As 1/3 of nickel is carried by pyrrhotite the nickel content of sulphide phase is low meaning (0.845%) that the grade of bulk sulphide concentrate remains very low and the mass percentage of concentrate is high. Another challenge is graphite which as a naturally floating mineral easily reports to concentrate in flotation. A low-grade concentrate containing 0,67% Ni with the nickel recovery of 74% could be produced by flotation. The amount of concentrate was 34,5% of the mass of ore feed. The recovery was about 91% for copper and zinc and 89% for cobalt.

The use of microbes as activators, depressants or collectors during bioflotation tests with the ore (WP 3) failed to improve the concentrate recovery or grade compared to flotation tests. Out of the three tested bacterial strains (*Staphylococcus carnosus*, *Bacillus firmus* and *Bacillus subtilis*), the minor hydrophobic strain *S. carnosus* yielded the best test results.

In WP3, an acidophilic thermophilic iron and sulphur oxidizing microbial consortium was selected for bench-scale bioleaching tests of complex polymetal black shale ore and concentrate in stirred tank reactors. In the flotation concentrate, the valuable base metals were enriched by a factor of 2.5-3 and the sulphides made up about 31 and 81% of the mineral composition of the Talvivaara ore and concentrate, respectively. The scoping studies successfully demonstrated thermophilic bioleaching of black shale at pulp density up to 20% and temperature up to 76°C in stirred tank reactors. In summary, the black shale ore and concentrate were easily leached with base metal yields near 100% (Ni, Zn, Cu and Co) in stirred tanks. A comparison of different bioleaching studies on Talvivaara ore and concentrate indicated the strong increase in Cu-yields with temperature (30 vs. 45 vs 69°C). In some tests pyrrhotite and pyrite were incompletely leached. The main leaching products were jarosite and gypsum. The formation of Fe-sulphate, goethite and elemental sulphur was minor. However, since the grade of valuable metals (Ni, Zn, Co and Cu) in the flotation concentrate was very low it was concluded that from an economic point of view this route was not an option. Further, flotation and some bioleaching tests resulted in pyritic tailings/residues, which are troublesome from an environmental perspective.

The second processing route (heap bioleaching of agglomerated ore) was also extensively studied. At GTK, about 140 tons of the 200 ton ore sample was crushed to particle size 0-12 mm, agglomerated and 110 tons loaded to a pilot column. The pilot column for heap bioleaching tests was inoculated with a mixed culture of acidophiles enriched from waters near the Talvivaara ore body. In March 2005, the pilot column tests started at outdoor temperatures of -10°C and yielded +25°C warm effluents containing Fe, Mn, Zn and Ni within the first week of operation. Thereby, providing a strong indication of the applicability of the process in sub-arctic environmental conditions. The pilot column was operated and regularly monitored for 27 months. The decrease in base metal content during leaching corresponded well with a depletion of sulphide minerals in the column. Bioleaching of black shale ore progressed well in the top part of the GTK pilot column (recovery Zn 86%, Ni 94%, Cu 60%, Co 75% after 27 months).

Talvivaara Mining Company Ltd. (TVK) carried out simultaneously with the Bioshale pilot column tests TVK's own pilot plant trials at deposit site. In July 2005, a 17 000 ton demonstration plant was constructed by TVK at Talvivaara. A representative ore sample was mined, crushed to 80 % -8 mm, agglomerated and built to two 8 m high heaps. Irrigation of the heaps started in August 2005. One pilot heap was inoculated with indigenous mesophilic and thermophilic bacteria collected from the site. The start-up of the solution flow resulted soon in elevated temperatures of over 50°C in the pregnant leach solution. The rise is due to the oxidation of the large quantity of pyrrhotite and pyrite in the ore. The elevated temperatures have also been maintained over the sub-arctic winter conditions. In the pilot heap bioleaching trials of TVK, Ni and Zn were leached over 90% within 1.5 years. In June 2007, TVK decided to invest 452 MEUR till 2010 for the development of the mine. In September 2007, the unemployment rate was 12% in the Kainuu region in which Talvivaara is located. Some 5000 persons are seeking employment in Kainuu region and the mine development has been estimated to generate some 3200 person-working-years. When in operation, the direct need for labor force might be 400 person-years in Talvivaara. The mine will additionally promote generation of some 600 workplaces at bulk chemical producers and smelters and about 1500 new working places are expected to be generated in the service sector. The Talvivaara deposit has about 340 Mt of resources with an estimated value of 6 700 MEUR during mine life of 25 years. The anticipated production is equivalent to 2.3% of the world Ni-production, and thus will increase Europe's Ni production by 100%.

In WP4, samples of pregnant leach solutions from the two pilot bioleaching test operations were provided by GTK to Bioshale partners for metal recovery studies. In WP5, GTK performed a mineralogical and geochemical characterization of the Talvivaara black shale ore sample, (bio)leached materials and solid waste samples of hydrometallurgical tests including metal recovery. The studied hydrometallurgical waste samples of bench-scale metal recovery tests on Talvivaara ore heap bioleaching solutions contained small amounts of sulphides. Further, the waste samples contained significant amounts of Co, Zn and Ni present as carbonates, hydroxides, oxides and sulphates. Thus, the solid waste of metal recovery would require special attention for their disposal. In WP6, GTK contributed to the mid-term evaluation of the process options, the environmental impact report, thermochemical scoping studies on heat production in heaps, and the final evaluation report of new process route of heap bioleaching of the Talvivaara black shale ore.

Dissemination activities at GTK included distribution of a Project flyer in Finnish, 13 oral presentations out of which 6 given at international scientific conferences, a layman publication in Finnish and 5 scientific publications (in preparation).

The impact of the RTD actions at GTK is manifold. The successful start-up of the pilot heap bioleaching tests at GTK provided the confidence that bioleaching operation are applicable during sub-arctic winter and supported the plans of Talvivaara Mining Company Ltd. of pilot-scale heap bioleaching trials at the mine site. Further, GTK developed within the Bioshale project parameters for integrated processing of black shale ores at bench and pilot scale, which are ready to be used in confidential technical customer services of the Mineral Processing Laboratory of the Geological Survey of Finland. Successful demonstration campaigns on black shale ore processing and bioleaching enable mining companies to select from different processing alternatives and thus, might allow the development of a mine due to improved economic viability (pre-feasibility and bankable studies).

Partner name: Helsinki University of Technology (HUT) Partner number: 7	 <p>TEKNILLINEN KORKEAKOULU TEKNISKA HÖGSKOLAN HELSINKI UNIVERSITY OF TECHNOLOGY</p>
Author(s): Kirsti Loukola-Ruskeeniemi, Olof Forsén, Jari Aromaa, Klaus Einsalo, Istvan Galfi	

1. Project execution

D1.1, D1.3, D6.2

- Compilation of available geological, mineralogical and geochemical data from the three study areas
- Comparison with information from black shale deposits in other parts of the world
- Complementary sampling of black shales and geochemical and mineralogical studies
- Geological samples were selected for WP3 and WP4
- Environmental impacts of black shale formations were evaluated in natural conditions (i.e. before mining), during mining and after mining.
- Sulphides are easily oxidized in near-surface oxic conditions releasing heavy metals and causing acid rock drainage. On the other hand carbonate minerals, if available in abundance, have acid neutralisation capacity. In Talvivaara, the geological formation does not practically include Ca-rich rocks, but in Lubin, carbonate rock layers are abundant.
- Talvivaara black shale deposit provides an ideal case to study processes in natural conditions. Time scale of the observed processes can be dated to the last 10 000 years. Natural environmental impacts of black shales form the background, against which industrial and other anthropogenic environmental impacts have been evaluated. Natural environmental impacts can seldom be controlled by man, rates of processes may be slow but, on the other hand, time scales may be very long. Lake sediment profiles appeared to be a useful tool for the evaluation of natural background in glaciated terrain
- Geological modelling of the Talvivaara black shale formation was carried out and the results were compared with black shale formations in other parts of the world. New ideas for the exploration of black shale ore deposits were created.

Workpackage - WP4 - Hydrometallurgy

The Hydrometallurgy research was aimed at designing hydrometallurgical treatments after bioprocessing from selective separation of the metals and recovery of the valuable metals in a marketable form. The Laboratory of Corrosion and Materials Chemistry worked on optimization of hydrometallurgical leaching process to obtain maximal product recovery. An oxidative mineral dissolution process depends on the solvent to keep dissolved metals in solution and on the oxidative power to maintain suitable reaction rate. The problems in sulphide mineral leaching are form of sulphur reaction product and iron dissolution. During dissolution sulphur may remain in amorphous form enveloping gradually the dissolving particles and the dissolution is hindered. Sulphur may also be oxidized to sulphate, which increases the consumption of reagents or energy. Dissolved iron, in turn, disrupts the process by consuming reagents and energy and it may also contaminate the products.

The work concentrated on selecting an optimal solvent-oxidant combination to:

- Develop oxidizing leaching process for the black shale ore in order to improve Ni, Cu, Zn recoveries by atmospheric and pressure leaching and as a complementary treatment to bioleaching.
- Control the behaviour of iron during leaching.

Electrochemical and chemical leaching tests were used to develop a kinetic leaching model. Sulphuric acid is the most widely used solvent. The reagent concentration, temperature, and agitation are the principal parameters that influence the leaching rate. For Talvivaara ore the results show that increasing pH increases formation of a reaction product layer. This happens above pH = 2. The dissolution rate increases when the surface potential of the leached material is above 650 mV SHE. The selectivity of metal dissolution is affected by the potential. The selectivity of the valuable metals (Cu, Mn, Ni, Zn) was good at potentials 550-650 mV. When potential was higher, iron dissolution became prominent and the relative amounts of valuable metals decreased. Temperature should be above 53 °C to increase the general dissolution rate. The dissolution of powdered Lubin shale and shale concentrates samples were studied with polarization curves and potentiostatic tests in the potential range of 500-900 mV and at temperature 23 °C. Because the metal sulphides are finely distributed in the carbonate matter (about 18% CaCO₃) a sulphuric acid treatment was used to enhance dissolution. Acidic non-oxidative leaching of the shale ore or concentrate involves chemical reactions between sulphuric acid and calcium or magnesium carbonates. The dissolution begins almost immediately when the sample potential is increased. The current density does not change much. The same dissolution stages and mechanisms as with Talvivaara ore are not seen. The current densities for Lubin ore are of the same magnitude as for Talvivaara ore, but the current densities of Lubin concentrate are ten times higher. The current densities for Lubin ore are lower as for Talvivaara ore, but the current densities of Lubin concentrate are slightly times higher. The curves reach fairly soon a steady state indicating formation of a reaction product layer and the controlling mechanism is mass transfer through the layer.

2. Dissemination and use

D1.1, D1.3, D6.2

The results have been presented in several conferences and for general public and several publications are in preparation. A PhD thesis focusing on environmental impacts of black shale deposits will be published in 2010.

Workpackage- WP4 - Hydrometallurgy

The work in developing and testing the mineral characterization procedures has been presented in the European Metallurgical Conference in Düsseldorf in June 2007 and a plenary presentation of the main results and their impact on industrial leaching processes was given in the XII International Conference of Mineral Processing in September in Szklarska Poreba, Poland. A Ph.D. thesis focusing on leaching test methods for powdered mineral samples will be published in 2008.

Partner name: TÉCNICAS REUNIDAS Partner number: 9	
Author(s): Jesús Palma, Francisco Sánchez, J.I. Lozano & A. Ibáñez	

1. Project execution

The BIOSHALE project aims at evaluating biotechnologies for the safe, clean and viable beneficiation of black shale ores and at designing an innovative model of development of the mining activities.

Two types of European black shales have been studied regarding their applicability to the bioprocessing: Polish black shales (Lubin) and Finnish black shales (Talvivaara). The study has comprised technical, environmental as well as biological aspects.

The specific project objectives for Técnicas Reunidas have been to design and study a bio-hydrometallurgical route for the processing of black shale materials with the aim to recover the most valuable metals in a marketable form, and with the knowledge acquired, produce a preliminary basic engineering design package that will allow to evaluate the economical potential of the proposed bioprocess.

In this sense, main tasks of Técnicas Reunidas have included process design, downstream processing tests, support to the environmental studies, definition of an analysis procedure to evaluate the potentiality of bioprocess alternatives and finally, preliminary basic engineering design followed by a preliminary economic evaluation of the most promising process variant.

Process design:

Information for a preliminary selection of the most suitable processing routes, for Lubin and Talvivaara raw materials, has been collected. Process case variants have been proposed, all of which include a first step of bio-processing. After that, a testwork programme has been planned for the experimental study of the proposed alternatives.

With Lubin material, atmospheric and pressure leaching has also been proposed as an alternative to bioprocessing only for comparison purposes.

Downstream processing tests:

Técnicas Reunidas has been involved in the downstream testing of samples generated by other Bioshale partners. As a first approach, synthetic samples have been used. When real samples were received, optimisation on them was done. Work has included the conditioning of the solutions, concentration and purification tests and finally metal recovery tests. An example of the purification tests carried out is shown in Figure 1 which shows solvent extraction tests for the recovery of Ni.

Special attention was paid to the behaviour of solutions coming from a bio-processing (bio-heap leaching or bio-leaching in stirred reactors), since processing technologies for metals recovery using hydrometallurgy have never been used for mineral processing containing organic matter as it is the black shale case.

Conditions for the recovery of metals such as Zn and Ni for the Talvivaara type materials, and Cu and Ag for the Lubin type materials have been established.



Figure 1. Lab scale SX tests.

Support to the environmental studies:

Residues from Talvivaara and Lubin process alternatives have been prepared and characterized and delivered to Bioshale partners responsible of environmental aspects.

Definition of an analysis procedure to evaluate the potentiality of bioprocess alternatives:

This tool has been applied to the evaluation of the process variants for the Lubin cases regarding their efficiency towards the objectives of a cleaner production for the European mining industry. Also, economic viability analysis was developed and most promising case was selected.

As a result, Lubin mineral current processing alternative was chosen as base case and two alternatives from the proposed process case variants were analyzed.

Basic engineering design and preliminary economic evaluation:

Due to the brilliant results obtained using moderate temperature in Lubin concentrate bioleaching test work; as well as the excellent silver recovery from bioresidue processing, it was decided to evaluate this process route as the most promising route.

The importance of this choice resides in an effort to evaluate the feasibility of implementing a bioprocessing plant based on tank agitated bioreactors. While the use of bio-heap leaching for sulphide base ores/concentrates of low grade is widespread, the use of bio-leaching although it has been a success from the technical point of view, has never been implemented at commercial operation scale due to unfavourable economics.

For the conceptual engineering study, process simulation was carried out (see Figure 2). Process parameters have been based on experimental studies done by the different WP and also on TR's know-how in hydrometallurgical processes. A process block diagram has been produced and from the process simulation, a mass balance was completed.

This work has culminated in a preliminary economic evaluation of the process. Operating and Investment cost were calculated and an estimation of the revenue generated by the process products was done showing promising results.

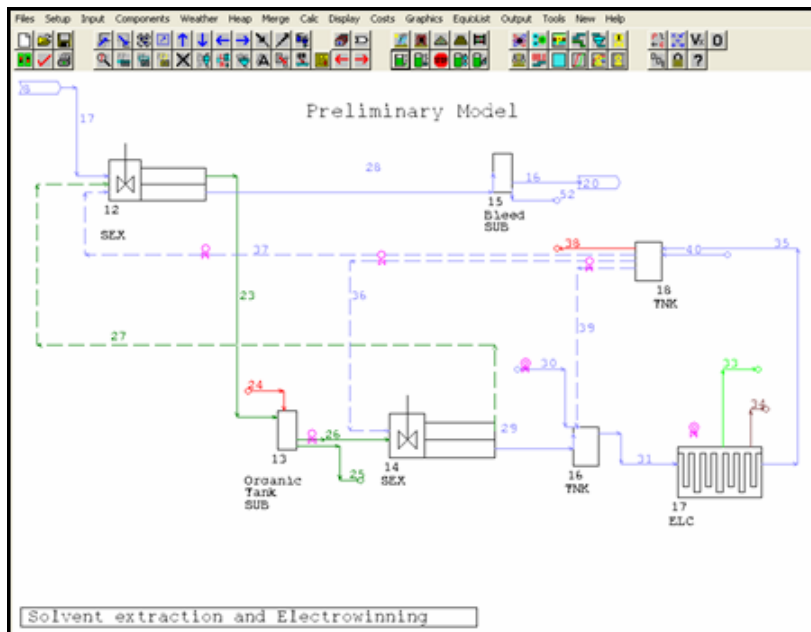



Figure 2. Process simulation of copper SX-EW plant.

2. Dissemination and use

During the course of the project, the following usable results have been identified:

- New hydrometallurgical downstream processing of bioleaching solutions. This process is addressed to the Mining and Metallurgy sector and it is due for commercial use after 2008.
- Simulation tool for hydrometallurgical downstream processing of bioleaching solutions. The software model is addressed mainly to the Mining and Metallurgy sector and is planned to be commercialized after 2008.
- Integrated process for Cu, Zn, Ni & Co recovery from black shales. This process is addressed to the Mining and Metallurgy sector and it is due for commercial use after 2008.

In addition to this, dissemination activities of the project progress have been carried out. Among them, Técnicas Reunidas has contributed to two publications that have been issued to specialized audience (in the IBS 2007: Biohydrometallurgy From the Single Cell to the Environment, "The Bioshale project: search for a sustainable way of exploiting black shales ores using biotechnologies" and in Minerals Engineering, "Bioshale FP6 European project: Exploiting black shale ores using biotechnologies?"). Also, Técnicas Reunidas has published a series of news and general information about the project in different media such as press, TR's website (www.tecnicasreunidas.es) and flyers.

Partner name: University of Wales, Bangor Partner number: 10	
Author(s): D.B. Johnson, K.B. Hallberg, K. Coupland, & K. Wakeman	

1. Project execution

Bioprospecting for micro-organisms associated with black shale ores

An inventory of indigenous acidophilic micro-organisms at the three sites of study (Lubin, Talvivaara and Mansfeld) using a combination of molecular biology and conventional (cultivation-based) microbiological techniques was carried out. As part of this exercise, acidophiles were isolated and their identities confirmed by sequence analysis of their 16S rRNA genes. Microbial populations at each of the sites was also assessed by analysis of 16S rRNA genes amplified from DNA extracted directly from environmental samples.

Acidophilic micro-organisms were successfully isolated from all three sites, though by far the most productive samples, both in terms of numbers and biodiversity of isolates, were slurry and water samples taken from the Talvivaara area. Isolates included the more familiar acidophiles (e.g. *Acidithiobacillus ferrooxidans*) and also more unusual Gram-positive iron-oxidisers and at least one bacterium (related to "*Thiobacillus plumbophilus*") that appears to be a novel species. The Lubin site yielded few acidophiles, though a moderately acidophilic iron-oxidizer of the genus *Alicyclobacillus* was isolated from an enrichment culture inoculated with sediment from a stream draining the large tailings deposit at Zelazny Most. Similarly, only one iron-oxidizing acidophile was isolated from samples of black shale taken from the spoil heaps at Mansfeld.

From this work it can be concluded that the acidophilic micro-organisms necessary to carry out biooxidation and liberation of metals from black shale ores can be found associated with that material. That the Mansfeld and Lubin sites did not yield many cultivatable acidophiles is not surprising. Both ores contain significant amounts of carbonate material that would neutralize any acidity produced during sulfide mineral oxidation. The detection of iron-oxidizing acidophiles at both the Mansfeld site and Lubin tailings, however, does have implications for long-term environmental issues. Such micro-organisms are capable of catalyzing the dissolution of sulfide minerals contained within the black shales, which may lead to the formation of pollution in the form of acid mine drainage (highly acidic solution containing elevated concentrations of toxic metals and metalloids).

Screening and assessment of microbial cultures for ability to leach metals from black shale ores

Selected pure cultures and microbial consortia were tested for their abilities to catalyze the oxidative dissolution of sulfide minerals contained in black shale and black schist from Lubin and Talvivaara. Leaching studies were carried out at 30°C, 37°C and 45°C in shake flasks containing an acidic growth medium to provide nutrients for microbial growth and the finely ground ore material to provide sulfide minerals as energy source. Leaching ability was determined as release of metals from the ore; Ni and Cu in the case of the Talvivaara ore, and Cu from the Lubin "middlings". Due to the high content of carbonate material in the Lubin "middlings", it was necessary to pretreat this material with sulfuric acid first to preclude neutralization of the acid during leaching.

Of a total of fourteen (pure and mixed) cultures of acidophiles tested for their ability to bioleach acid-pretreated Lubin "middlings", two cultures (a UWB consortium and a pure culture of an acidophile isolated from Mansfeld) were the most efficient at solubilising copper. All (100%) of the total available copper

was released within a 5 week incubation period. Another UWB consortium was the most effective of those cultures tested at 45°C (again extracting 100% of the available copper). Eighteen cultures were screened with fine-grain Talvivaara ore. Mixed cultures again proved the most effective at leaching metals at 30°C, with the mesophilic UWB consortium solubilising almost 100% Ni and Zn within 6 weeks. At 45°C the moderately thermophilic UWB consortium was found to be effective at bioleaching Talvivaara ore, leaching 100% of both nickel and zinc, and in this instance more copper than at 30°C (48% vs 24%) after 7 weeks culture incubation. This culture also released 42% of the total cobalt.

An important part of this exercise was to determine which micro-organisms emerged as stable consortia in the most effective cultures. In both cases, these were the UWB consortia, which included different bacteria and archaea in the initial inocula. These were positively identified in all cases, using a combination of state-of-the-art cultivation-dependent and biomolecular techniques. Very different bioleaching microflora were detected in cultures containing the Lubin middlings or the Talvivaara ore.

Such results clearly show that metals from black shale/schist ores can be readily and efficiently solubilised using classical bioleaching cultures. The key micro-organisms identified were passed on to Bioshale partners for further bioleaching experiments at larger scale to improve process kinetics. Furthermore, the results of the microbiological analyses provided data that proved useful in comparing the lab-scale studies with large-scale pilot studies (see below).

Laboratory-scale column leaching experiments

The previous studies were carried out using finely ground black shale/schist ore (< 0.1 mm size particles). In heap leaching operations the particle sizes would be anticipated to be much larger (as ground or agglomerated ore). Therefore, we studied the effect of ore particle size on leaching efficiency by filling two columns with crushed, non-sterile Talvivaara ore. One column contained particles of 2.0 - 6.5 mm diameter and the second had particles of 6.5 - 12 mm diameter. Both columns were inoculated with a mixed population of acidophiles, including mesophilic and moderately thermophilic acidophiles and incubated at 37°C.

Over a period of 15 weeks, the pH of liquor taken from the column reactors slowly decreased from pH 5 to between pH 3.5 and 4.0, indicating that microbial populations were active in both columns. This was supported by a gradual increase in redox potential of the column leachates (indicating oxidation of ferrous iron to ferric), which increased more rapidly in the column filled with the smaller ore particles. The most readily leached metal in both column reactors was manganese. After 40 weeks, 60% of the manganese had been leached from the coarse ore and more than 85% from the finer grade ore. Nickel was the next most readily leached base metal. By the end of the experiment, ~9% (coarse ore) and 23% (fine ore) of the total amount of Ni in the column reactors had been solubilised. A low amount of zinc and no copper was detected in the leachate from either column after 40 weeks. Interestingly, during the course of this experiment, an unexpected and dramatic increase of soluble ferrous iron concentration (up to 250 mg/l) in the column leachate from the larger ore particles occurred, which eventually decreased to near 0 mg/l by week 35.

The microbial population in each of the columns was also assessed. Overall the population profiles within each column were similar, though there were variations between the populations in each column. In particular, the population in the column containing the coarse ore was initially dominated by an acidophile that originated from the ore itself. For both columns, a second population of acidophiles arose after about 8 weeks of incubation. This included Gram-positive iron-oxidizing acidophiles from the inoculum. These organisms were eventually succeeded by a population that consisted of the iron-oxidizing acidophiles *Acidithiobacillus ferrooxidans*, *Leptospirillum ferrooxidans* and *Leptospirillum ferriphilum* (all of which were in the original inoculum). Other acidophiles from the inoculum were also consistently detected. These included the iron-reducing acidophile *Acidiphilium* sp. SJH (the appearance of which coincided with the increase in soluble ferrous iron in the coarse ore column).

Analysis of microbial populations of pilot-scale heap leaching operations; GTK tower and Talvivaara pilot heaps

Two pilot-scale heap leaching operations were studied, including a simulated heap of 110 tons of agglomerated Talvivaara ore established by the Bioshale partner GTK ("GTK tower") and a 50,000 ton heap built and operated by the Talvivaara Mining Company. The microbial populations in each operation were studied by cultivation (e.g. enumeration and isolation of acidophiles on solid media) and by biomolecular analysis. The latter included extraction of DNA from samples of each operation and PCR amplification of 16S rRNA genes. In the case of the Talvivaara heap, RNA extractions were also performed; this permitted the study of active microbial populations.

During a period of over 1 year, the population in the GTK tower evolved from one originally dominated by *Acidithiobacillus ferrooxidans* species (belonging to two distinct phylogenetic groups), to a population that was dominated by two previously undetected acidophiles. These included one bacterium that is related to other well-known iron-oxidizing heterotrophic acidophiles and one that has only been detected by biomolecular analysis in acid mine drainage impacted sites. Interestingly, the microbial population in samples taken from the heap (which had been operated for over 1 year at the time of sampling) resembled that of the GTK tower. In contrast, the microbes in the leach solution and in the oxidation ponds differed somewhat, with iron-oxidizing autotrophs such as *At. ferrooxidans* and *Leptospirillum ferrooxidans* proving to be the dominant active bacteria. A wide range of acidophiles have been isolated from samples of the heap solutions and solids, and include many acidophiles known to be important in bioleaching. These include both mesophilic and moderately thermophilic acidophiles, with the latter type proving to be more prevalent.

That the active bacteria in the leach solutions are iron-oxidizing acidophiles is no surprise, and correlates well with the solution chemistry. The heap contained a wider variety of micro-organisms than the 'GTK tower' column. This is probably because the much larger heap provided a greater diversity of localized sites that were able to support the growth of different micro-organisms. These studies (along with the performance of the pilot-scale leaching operations) confirmed that laboratory based studies (which demonstrated the classical bioleaching approach) using acidophilic micro-organisms can also be applied with confidence to the black shale/black schist ores. In addition, new acidophilic micro-organisms have been detected, and further studies will provide key information into the diversity and utility of these new acidophiles.

2. Dissemination and use

Much of the above research has been presented in either oral or poster form at the 17th International Biohydrometallurgy Symposium, held in Frankfurt in September 2007. These presentations have also led to the publication of several short papers in the special issue of *Advanced Materials Research*. In addition, several scientific papers are being written about the various aspects of the research described.

Many of the results obtained in this study have supported the mining and metal extraction operation by the Talvivaara mining company. The close contact with the Company and the Bioshale project has facilitated exchange of research results and ideas.

Partner name: University of Warwick Partner: 11	
Author(s): Paul Norris	

1. Project execution

The microbial processing of black shale materials was investigated using thermophilic microorganisms. These organisms were chosen for two principal reasons.

1. Previous experience had shown that the most rapid and efficient biological processing of copper-containing mineral sulfide concentrates could be carried out at high temperatures.
2. The nature of the black shale ore to be processed (i.e., a high pyrrhotite content) was predicted to result in high temperatures during any biological heap biomining operation.

Black shale concentrate processing

Shale concentrate from Lubin was processed using a mixed culture of thermophilic microorganisms (acidophilic archaea) which was previously used successfully on the EU-funded HIOX project. Essentially complete, rapid extraction of copper was obtained at 78°C, as expected. The likelihood of a commercial development of the process was considered poor however because of the relatively low copper content of the available concentrate in relation to the predicted cost of a large scale process operation.

The nature of the copper mineral (principally chalcocite) could be more suited to less expensive, lower temperature technology, which could also leave residues more amenable to recovery of the silver present in the concentrate. Consequently, although the most efficient copper extraction route was demonstrated, further development of the high temperature option was not pursued.

Black shale ore leaching

The association with the Bioshale project of a company developing heap leaching of a black shale ore deposit in Finland provided direct relevance to the investigation of microbial activity in metal extraction at high temperature. In parallel to this laboratory investigation, a demonstration heap in Finland (Talvivaara Project Ltd.) indicated that high temperatures (up to at least 80°C) were an inherent part of the process operation.

Methodology. Laboratory leaching columns were used to simulate the heap leaching process. Each column contained 0.7 kg of ore (average ore fragment weight of 1 gramme). Columns were operated for up to 365 days. Two types of microbial culture were used:

- (i) At 47°C, a well-studied mixed culture of moderately thermophilic, ferrous iron and sulfur-oxidizing bacteria was used: this principally contained *Acidithiobacillus caldus* and species of *Acidimicrobium* and *Sulfobacillus*.
- (ii) At 68°C, initial column experiments utilized *Sulfolobus metallicus*. Later work used a mixture of *Sulfolobus*, *Metallosphaera* and *Acidianus* species. Eight different cultures of high temperature organisms were investigated in relation to their pH tolerances during leaching of the Talvivaara ore, to ensure that the chosen organisms would be active at the pH range dictated by the nature of the mineral during processing under conditions simulating close to those likely to be used in the potential industrial process.

Results.

The role of the microorganisms in extraction of various metals from the ore (nickel, zinc, cobalt, manganese and copper) was established through comparison with sterile systems operated with and without provision for chemical (ferric iron) leaching. Two major series of experiments were run for 365 days and 130 days. The advantages of a microbial process were clearly demonstrated.

Extracted metals and metals remaining in the final (leached) residue were measured. Approximately 70% extraction of nickel and zinc indicated results were similar to the demonstration heap and confirmed that there were no unexpected technical problems that could impede development of a commercial process. However, examples of poorer than expected extraction were encountered in cases where microbially-catalysed oxidation of ferrous iron resulted in aggregation of iron-rich precipitates which impeded or channelled solution flow.

By comparison to ferric iron leaching in sterile systems, it was demonstrated that nickel, zinc and cobalt leaching was comparable in inoculated and ferric iron systems, copper leaching was specifically dependent on the microbial activity, and manganese leaching was not directly correlated with microbial activity. The important contribution of the microbial activity in a large scale operation is expected to be the regeneration of the ferric iron oxidant in situ.

A preliminary identification and investigation of the thermophiles present on site in Talvivaara indicated that these probably do not have the capacity of other known strains to operate efficiently at the higher temperatures found in the demonstration heap.

2. Dissemination and use

Sufficient data was obtained from the black shale ore column leaching investigation for a detailed assessment of the results significance in relation to the heap leaching development by the associated partner, Talvivaara Project Ltd. In addition, two publications are being prepared for wider dissemination in the appropriate scientific literature.

With reference to the column/heap work, this investigation has clearly indicated a need for further research with regard to the optimum operation of an industrial process. In particular, serious research/consideration should be given to inoculation with more useful organisms and monitoring/optimisation of the microbial ferrous iron oxidation. The latter has to be developed within the physical/engineering problems of solution flow that have been shown to be influenced by the microbial activity at high temperature.

Partner name: G.E.O.S. Freiberg Partner number: 12	
Author(s): Dr. Franz Glombitza, Dr. Jana Pinka	

The partner G.E.O.S. Freiberg was involved in the WP1, WP2 and WP6.

WP1

WP1 contains the description of the black shale ore deposits and the attempt of a description of the environmental impact of these ore bodies before, after and during the mining activities.

A summary of the existing knowledge of the Geology and Mineralogy of the study area Mansfeld and a description of the ore horizons of the mining field was the first task of the group of G.E.O.S..

References were collected and reported by the WP 1 leader.

An excursion trip was organised, that took place at the 21st and 22nd of April 2005. The excursion was planned as a sample-taking trip. The aim was to give the microbiologists of the Bioshale project the possibility to take samples, from which they can isolate microbes.

The partners decided according to their part of Bioshale what kind of samples they want to investigate.

During the field trip the group visited several kinds of heaps. They differ in:

- the location within the Mansfeld-Sangerhausen mining area
- the age of the origin of the heaps
- the content of residual metals, the composition of the heap material
- the shape (flat, spiky), the area and height of the heaps.

Seepage water that leaves the different kinds of heaps was investigated also.

The microbiologists collected both solid and fluid materials, to describe the microbiological inventory, to make leaching tests with the isolates. The geochemists were able to interpret the release of elements by studying the historical data, by reading the environmental impact reports and by analysis the release results of the microbiological examinations.

The content of the report D1.3 covers the action of microorganisms before, during, and after mining activities and the correlation between microorganisms and environmental influencing parameters.

The report contains the description of the situation in Talvivaara, written by the finish partners HUT and GTK, and the description of the situation on Lubin and Polkowice, written by the polish partner CUPRUM. The report contains also the situation in the different piles and dumps. Tailing ponds are described in D2.3.

A review of former investigations demonstrated an alteration of the chemical composition in dumps of the Mansfeld mining area. Delivery and transfer of harmful substances into the surface water can be assumed therefore. The analysed composition of some drainage water samples of two ponds confirmed this assumption due to the high concentration of zinc and sulphate in the water. This information were confirmed by different analyses of the water of some other piles and the composition of the water flowing in the mining region dewatering system Schlüsselstollen as well as of the last water quality report of the regional authority. A methodology was developed and applied for the prediction of the quality of different mining seepage waters. This methodology included the different microbiological activities and the results of these processes. A first proposal for the technical application and the first steps are integrated.

Beside a model for the treatment of the microbial delivery of heavy metals into the drainage water an algorithm for the detection of microbial activities was proposed.

WP2

First literature was collected due to the knowledge in geology, mining, processing, smelting and the influence of the mining and metallurgical industries in the presence and future.

A contribution concerning the history of the mining technology connected with the ore processing technologies and the production of the valuable substances from the ores was prepared. This material was transferred to the partners of deliverables 2.2 and 2.3.

The material contains the development of the different kinds of smelters, the treatment of the exhausting gas and the description of the different developed and introduced down stream and side processes for the production of available substances.

Main products besides Cu are Zn, Ni, V, Se, Ag, Au, H₂SO₄, Cd, Zn, Pb and Re.

WP6

D 6.1: Bioprocessing and mid term evaluation

3 different proposals for an alteration of the present technology exist.

A required scheme of evaluation was developed and proposed for an assessment of these substitutional technologies. The base idea consists in the fact that the new technologies have to offer some different advantages in comparison to the applied classical technology. That results in a comparison of the suggested new techniques with the present process.

The first advantage of biological processes during metal production is the low working / running temperature. Because the traditional metal production is a high energy consuming process, and therefore much more expensive. These costs will increase in the future.

The second advantage is the realisation of a closed water cycle in contrast to classical mining technologies and flotation processes.

The third advantage consists in the production of valuable side products and chemicals by means of a leaching process besides the classical ore processing and smelting technology (?)

A scheme was created for the evaluation and assessment of the different situations and technical conditions.

For D.6.4. this deliverable contains an assessment of the technologies

Suitable methods for carrying out impact assessments were studied for a comprehensive assessment and evaluation of new technologies. Therefore the different publications and their content were checked for an application on technologies. The last suitable paper is the publication „European Commission SEC(2005) 791 Impact assessment guidelines, 15. June 2005“.

These last guidelines replace the version from 2003 „Impact Assessment in the Commission - Guidelines“ and „A Handbook for Impact Assessment in the Commission - How to do an Impact assessment“. They set procedural rules for IA in the Commission and explain how to practically conduct the required analyses.

This guideline contains 3 topics for an assessment of projects, technologies, techniques or programmes. The three topics are economic impacts, environmental impacts and social impacts. These topics are subdivided with many key questions.

Partner name: University of Mining and Geology "Saint Ivan Rilski", Sofia, BG (UMGS) Partner number: 13	
Author(s): Stoyan Groudev, Irena Spasova, Marina Nicolova, Plamen Georgiev	

Heap bioleaching of copper from run-of-mine Lubin ore by means of acidophilic chemolithotrophic bacteria was efficient and 86.4 % were extracted within 150 days under laboratory conditions. However, the subsequent extraction of silver from the heap using different chemical reagents (cyanides, thiosulphate, hydrochloric acid plus sodium chloride) solubilized up to 51.2 % of this metal which can not compete with the data from the reactor leaching by means of these chemical reagents of bacterially pretreated flotation concentrate obtained by dressing of this ore.

Different carbonate-rich black shales were subjected to microbial leaching of copper at alkaline pH by means of different heterotrophic microorganisms (bacteria and fungi) and basophilic chemolithotrophic bacteria. The best results were achieved by means of a mixed culture of urease-producing bacteria which under certain conditions solubilized 70.1 % of the copper from Lubin middlings within 25 days of leaching. The alkaline bioleaching can not compete with the acidic bioleaching by means of chemolithotrophic bacteria but was used as a basis for development of biotechnology for in situ remediation of alkaline soils polluted with heavy metals and arsenic.

The pretreatment of black shales by means of some microorganisms (chemolithotrophic, silicate and sulphate reducing bacteria) improved to some extent the copper recovery during the subsequent flotation.

Various partially bioleached mineral samples during bioprocessing as well as final wastes and residues from such treatment were subjected to a detailed characterization for assessment of the environmental impact of these samples. The characterization included data about the chemical composition, mineralogical composition and structure, geotechnical and acid-base properties, mobility and bioavailable fractions of the heavy metals and arsenic, and solubility by means of different chemical and microbial tests. It was found that under certain conditions the samples generated drainage waters strongly polluted with heavy metals and arsenic. These waters were toxic towards different test-organisms such as the bacteria *Bacillus cereus* and *Pseudomonas putida*, *Daphnia sp.*, *Tubifex tubifex*, duckweed (*Lemna minor*), various terrestrial plants (salad, clover, oats) and earthworms (*Lumbricus terrestris*). Methods for prevention of the negative environmental impact of black shale processing and for remediation of the relevant post-mining areas were tested under laboratory and pilot-scale conditions.

The knowledge obtained during the project has been presented by lecture courses for BSc and MSc students of the University of Mining and Geology Sofia (UMGS), and at five international symposia and seminars, at which five scientific papers have been presented and published. Several other papers are in stage of preparation and will be published in the near future.

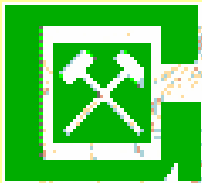
Partner name: Czech Geological Survey (CGS) Partner number: 14	
Author(s): Jan Pašava - Anna Vymazalová	

1. Project execution

The main objectives of the Czech group to WP1:

- Expert consulting to WP1 participating teams
- Study of the distribution of PGE in Cu-rich samples from Lubin and Cu-low samples from Polkowice and the study of comparative PGE-rich black shale samples from South China - scientific research related to Task 2.
- The study into the identification of the mode of occurrence of noble metals in comparative samples from South China (jointly with UW-FB and UWB) - scientific research related to Task 2.
- Evaluation of the distribution of environmentally harmful elements under natural conditions (Talvivaara, Finland), during mining (KGHM Polish Cooper, Poland) and after mining (Mansfeld, Germany) - Task 1.3

were addressed through the following project outcomes:

- Evaluation of the distribution of noble metals in additional samples from the Polkowice mine (included in D1.1 first version - June 2005, second version - January 2006)
- Environmental impact of black shale deposits, especially at KGHM Polish Copper, Talvivaara and Mansfeld (Task 1.3. with D 1.3. by TO+24 m)
- Various publications and presentations of scientific results at Bioshale meetings and international conferences

The main results:

It was confirmed that Cu-rich black shales of the Kupferschiefer type from Lubin (Poland) contain low PGE values and that Cu enrichment was most likely late diagenetic/epigenetic. Re/Os study of Cu-low but PGE-rich black shales from Polkowice resulted in errorchron age most likely due to a mixture of Os from various sources (seawater, detrital...). The study of comparative lower Cambrian samples of Mo-Ni (PGE) black shales from south China resulted in the identification of various organic metal compounds, thus confirmed the importance of organic matter in the accumulation of various (including noble) metals.

2. Dissemination and use

- Extended abstract Pašava et al. (2006): "OVERVIEW OF BLACK SHALE HOSTED DEPOSITS - BIOSHALE PROJECT" published in Program and short abstracts (S.V.Cherkasov ed.) p.80, Alfa Print Moscow and on CD. Poster was also displayed and presented at 12th Quadrennial IAGOD Symposium - August 2006 Moscow, Russia, the Symposium was attended by a. 400 people.
- Extended abstract: Pašava J, Vymazalová, A, Mao J, Du A, Qu W, Korzekwa W (2007): A Re -Os study of noble metal-rich black shales from the Polish Kupferschiefer. In: Andrew CJ (ed) Digging Deeper. Proceedings of the 9th Biennial SGA Meeting, Dublin, Ireland, vol 1, 221-224. The contribution (oral presentation) was presented at 9th SGA Biennial Meeting (August 2007) in Dublin, Ireland, the conference was attended by a. 650 people.
- Two abstracts were submitted to the Goldschmidt Conference, held in Frankfurt, Germany in August 2007 and were published in *Geochimica et Cosmochimica Acta*:

- Pašava J, Sklodowska A, Vymazalová A, Biernat A, Kříbek B, Orberger B (2007): Organometallic complexes from Ni-Mo-PGE black shales in South China - Combination of bioactivities, hydrothermal venting and phosphate deposition during global Cambrian biological explosion. *Geochim Cosmochim Acta - Spec Suppl.* 71 (15S), A763-A763
- Pašava J, Vymazalová A, Qu W, Korzekwa W (2007): Re-Os study of the polish Kupferschiefer: Implications for source and timing of metal enrichment. *Geochim Cosmochim Acta - Spec Suppl.* 71 (15S), A763-A763