



ADAPTIVE LASER CLADDING SYSTEM WITH VARIABLE SPOT SIZES

Research for SME

Grant Agreement n^o: **315614**

Call identifier: **FP7-SME-2012-1**

Adaptive Laser cladding System with variable spot sizes

ALAS

Final Report

Publishable Summary

"This project has received funding from the European Union's Seventh Framework Programme for research, technological development and demonstration under grant agreement No 315614"



Table of Contents

Final publishable summary report	3
1.1 An executive summary.....	3
1.2 A summary description of project context and objectives.....	3
1.3 A description of the main S&T results/foregrounds.....	5
1.4 The potential impact.....	18
Use and dissemination of foreground	24

Final publishable summary report

1.1 An executive summary

ALAS project (Adaptive laser cladding system with variable spot sizes) developed an innovative laser cladding head, focused on the repairing of complex geometries, controlling the effect of heat accumulation, yielding a new fully automated cladding system. The ALAS project develops three technological progresses with the complementary idea to make the laser cladding process more flexible, self adapted and easy to use:

- **Variable optical path:** ALAS project developed a variable optical system that ensures the performing of clad tracks with variable width simplifying the programming cladding strategy.
- **Heat accumulation control:** A Real Time-control system modifies laser power values in order to guarantee the characteristics of the laser cladding process, avoiding heat accumulation effects due to external factors (workpiece geometry, undesired speed variations ...).
- **High Level Control System.** It has been developed to be intuitive for the cladding operator; the operator can set-up the adaptive cladding process, only “sketching” the design of the part to repair, and setting the main parameters of the process. The HLCS interpolates laser beam widths at any point of a tool path and sends the obtained time-based table to the FPGA controller.

The project resulted in the realization of a fully functional prototype that represents a significant step forward into the industrial implementation of a new automated industrial laser cladding process specially adapted to laser repair and refurbishment industries, in which the problems of adaptation to variable surfaces and control of the heat accumulation have been the key-factors to solve. Thus, ALAS project has developed 3 technological progresses with the complementary idea to make the laser cladding process more flexible, self adapted and easy to use: Variable optical path, RT-monitoring and control of the laser power during the cladding and an user-friendly graphical interface.

1.2 A summary description of project context and objectives

The ALAS project aims to shorten the gap between research and economy with latest research activities in the fields of optics, measurement and control, by providing an innovative, **adaptive laser cladding system with variable spot size** to end users. Thus, Europe’s SMEs will be empowered to strengthen their global market position as the productivity will increase due to shortened setup times, flexibility gain and controlled quality.

The adaptive laser cladding system has potential to replace the actual cladding process in most real life applications. Currently, to process a cladding track with complex geometry, it is necessary to program several cladding paths (Figure 1, right). Using the adaptive ALAS cladding head, developed in this project, this tedious programming process will be eliminated (Figure 1, left).



Figure 1. : Left: production of a track using variable track width programming, right: production of the same geometry using multiple passes. The profit of the former in terms of production time is obvious.

The project objectives as included in GA-Annex I are as follows:

- **O1. Design and development of the optical path system.** (Related with WP2 and D2.1, D2.2, D2.3 and D2.4). To be achieved in Month 12.
- **O2. Design and development of the Real-Time control system.** (Related with Milestone 2 MS2, WP3 and D3.1, D3.2). To be achieved in Month 14.

- **O3. Construction of a prototype of the adaptive cladding head.** (Related with Milestone 3 MS3, WP4 and D4.1, D4.2). To be achieved in Month 16.
- **O4. Integration and assembly of the system.** (Related with Milestone 4 MS4, WP5 and D5.1, D5.2 and D5.3). To be achieved in Month 20.
- **O5. Validation of the system.** (Related with Milestone 5 MS5, WP6 and D6.1, D6.2 and D6.3). To be achieved in Month 24.

Thanks to the work developed by the consortium as a whole, these objectives have been achieved at 100%.

Table 1. Accomplishment indicator and deliverables related with the objectives.

Objective	WP	Task	Deliverable
Definition of user requirements and system performance	WP1	T1.2 T1.2	D1.1
Definition the specifications of validate procedures	WP1	T1.3	D1.1
Definition of performance requirements for variable optical path	WP2	T2.1	D1.1, D2.1
Optical design of the laser cladding head	WP2	T2.3	D2.1, D2.2
Opto-mechanical design of the laser cladding head	WP2	T2.1, T2.2	D2.2
Selection of the optical and coating material for laser cladding head	WP2	T2.4	D2.1, D2.2
To design and evaluate the monitoring system	WP3	T3.1, T3.2	D3.1
To design and evaluate the adaptive power control system	WP3	T3.3, T3.4, T3.5	D3.2, D3.3
To assembly and alignment the opto-mechanical system	WP4,	T4.1, T4.2,	D4.1
To assembly and integration between the opto-mechanical design of the cladding head and the RT-power control system developed	WP4	T 4.3, T4.4,	D4.2, D4.3
To develop and integrate the High level control system	WP,	T5.1, T5.2, T5.3,	D5.1, D5.2
Laboratory validation of the ALAS prototype	WP5	T5.4,	D5.1, D5.2
To characterize the system performance	WP6	T 6.3,	D6.2, D6.3
To transfer the knowledge from RTD to SMEs	WP7	T7.1, T7.2,	D7.5
To disseminate the results of the project	WP7	T 7.4	D7.1, D7.3, D7.5, D7.6, D7.7
To maximize the exploitation opportunities for SME partners	WP7	T7.3	D7.2, D7.4

1.3 A description of the main S&T results/foregrounds

The work plan followed in ALAS project is structured into eight work packages (WP) divided into different tasks, each one having a distinctive role towards the accomplishment of the project objectives.

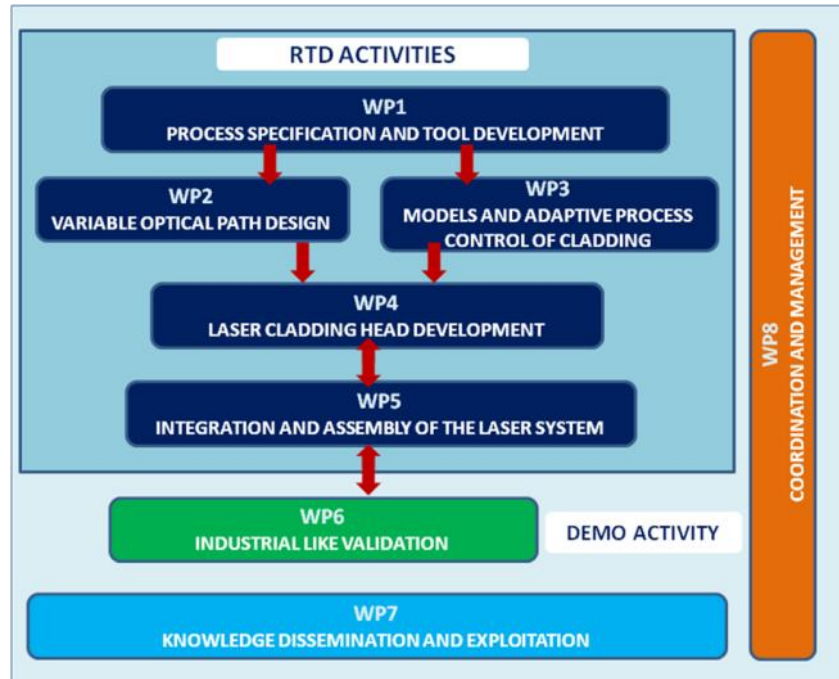

Figure 2 Interdependences of Work Packages

During the first period of the project, the main research activities have been focusing on defining process specifications and system development that includes the user requirements and system performance, the work piece definition and the specifications of validation procedures.

A concept of the innovative laser cladding head, developed in ALAS project is shown in Figure 3, which includes an adaptive optical path that control the laser focus distance on the fly, and I has a user friendly interface in order to simplify the programming of this variable tracks. Coevally, a monitoring system which controls the laser parameters depending on the process status will ensure a steady process quality.

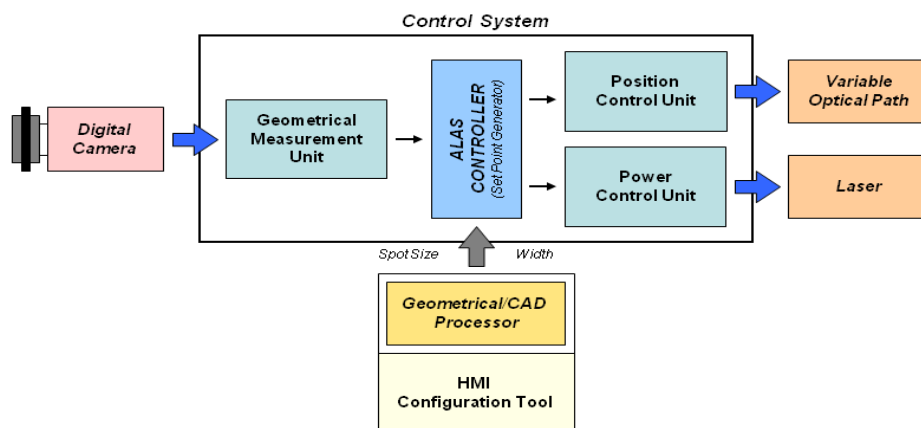

Figure 3 Concept for ALAS system

The end users have defined two different geometries to validate the ALAS system prototype; a cylinder piece to validate the control system in order to avoid the heat accumulation during laser cladding and complex geometries, to be reconstructed in order to validate the optical path system.

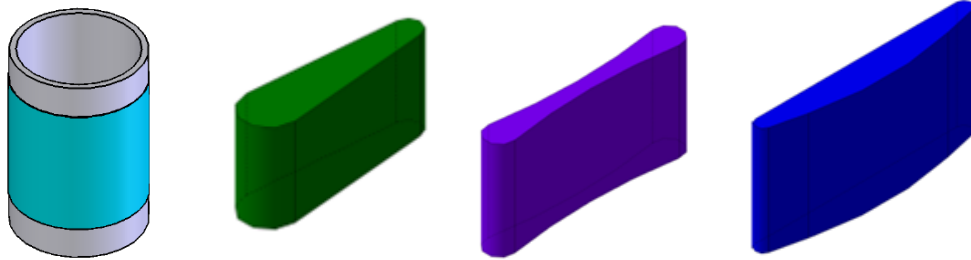

Figure 4 Selected geometries for validation of the ALAS system

The ALAS system has been designed and validated for High Power Diode Laser, HPDL-users with these specifications: wavelength optimized for **940nm** and optics system compatible with 808 and 980nm and diameter of spot size between **2.7-5.5mm** with a fiber of $\varnothing=1.5\text{mm}$.

The first-order requirements imposed on the system are:

\varnothing fiber: 1.5 mm

\varnothing spot : 2.7 – 5.5 mm

Focal length to collimation: 100 mm

Focal length to focalized: 150 mm

Zoom system magnification: 1.2x to-2.5X

The combination of 100 mm collimator and 150 mm focusing lens adds a magnification of 1,5x.

The total magnification range is: 1.8x to 3.75x.

The arrangement of the components of the optical zoom system is a combination of two convergent lenses and two divergent lenses, with two fixed lenses and two movable

Figure 5 shows the simulation of complete optical system with a plate beam splitter and ideal collimator and focusing lens.

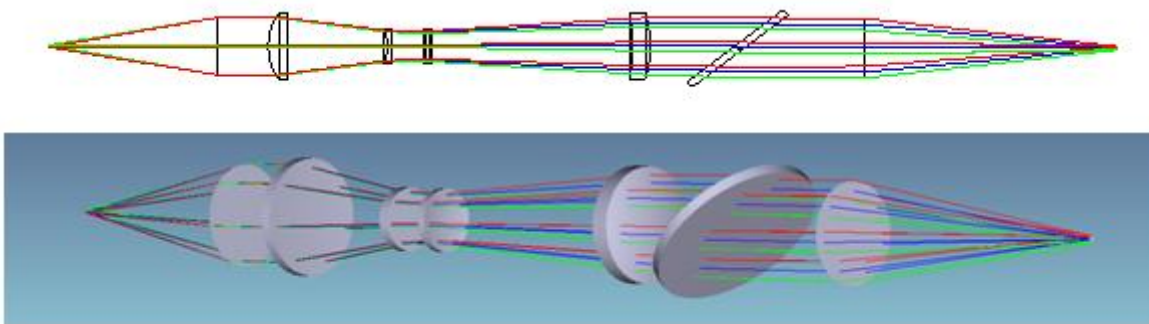

Figure 5. Simulation of optical system

Zoom equation describes the lens movement of the variator and compensator, L3 and L4 respectively, in order to obtain the magnification range. The movement of the variator is compensated by means of the movement of the compensator element, in order to keep the whole system afocal. Figure 6 shows different configurations of the system for different magnifications. Red line indicates the movement of each lens.

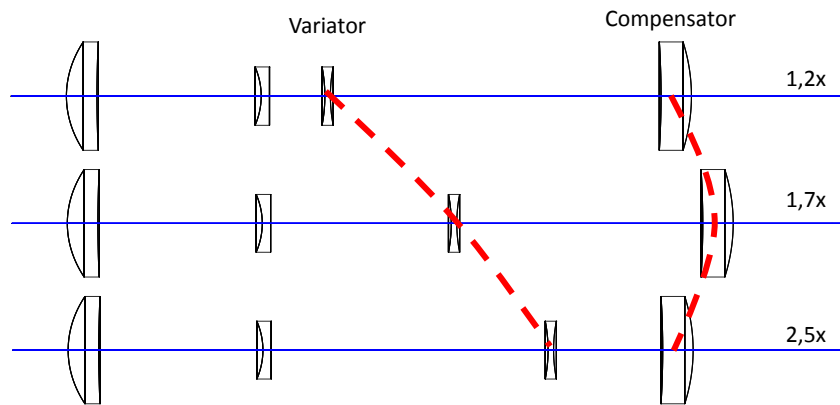

Figure 6. Scheme of lenses path on optical zoom system.

Table 2 summarizes the minimum requirements for the engines responsible for the lenses movement.

Table 2. Resume of mechanical requirements.

Lens	Travel range	Accuracy
L3	80,02 mm	0,1 mm
L4	29,1 mm	0,1 mm

The **heat sources** inside of a high power laser system as ALAS are due to light absorption in each component in the optical path. The most important parameter for the absorption at wavelength of 940nm is the OH content. The selected substrate to build the zoom optics system is the **Suprasil 3001**, with low absorption at working wavelengths due to its lower content in OH and other impurities. This absorption produces a very low warm on substrate, implying that there is no change in the focusing behaviour and, therefore, it is no necessary to refrigerate the lenses.

CAD modelling and assembling of the parts of the cladding head have been developed, including housing for the optical system and mobile parts, motors and actuators for controlling the ALAS system.

In Figure 7 (down), a sectional view of the system with the entire functionality is visible. The Zoom-Module has the dimension of 325 mm x 187 mm x 155 mm and a weight of about 10 kg.

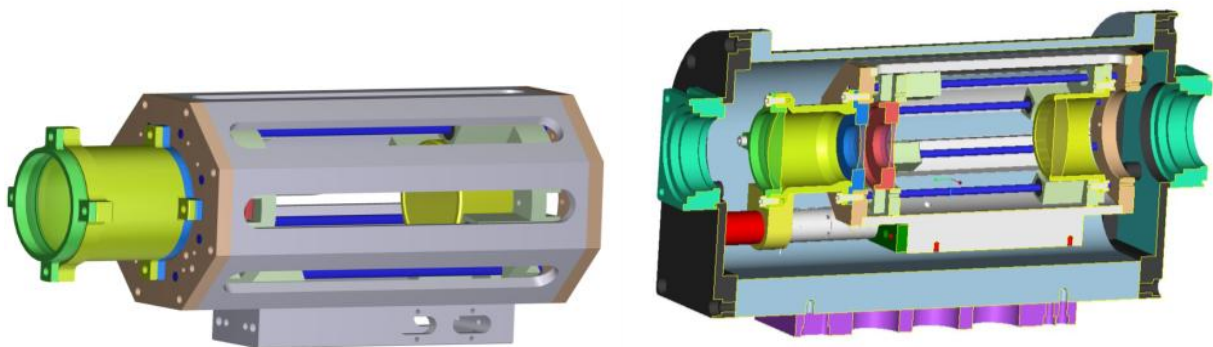

Figure 7. Octagonal monoblock. Sectional view of the Zoom Module.

REAL-TIME CONTROLLER

To manage in Real-Time condition all the parameters involved in the development of a variable cladding head, a new real-time control system based on machine vision and hardware control has been developed. This new controller ensures an efficient control of laser cladding process, focussing in two main technological developments:

- **Variable optical path:** A RT-control ALAS ensures the performing of variable clad tracks managing the position of the lenses of the optical zoom and simplifying the programming cladding strategy.
- **Heat accumulation control:** A RT-control system modifies laser power values in order to guarantee the characteristics of the laser cladding process, avoiding heat accumulation effects due to external factors (workpiece geometry, undesired speed variations ...).

The combination of the variable optical path and the laser power control enables the operation of the system in several modes.

The Real-Time control system is based on a FPGA board. Specifically, the Real-Time control system is based on ALTERA DE2-115 Development and Education Board through the use of Cyclone IV FPGA. This device supports the industrial camera connection through the CameraLink interface, and offers others communication interfaces like Ethernet to connect FPGA to external Human-Machine Interfaces (operator interfaces).

The architecture of the ALAS controller has been designed taking into account performance and development effort. A hybrid soft-hard architecture has been developed, where parts are in hardware and other parts are in software.

The FPGA system has been developed using ALTERA tools as SDK, and VERILOG as hardware description language and ANSI C as micro processor language. Besides a RT preemptive multitasking operating system (μ COS-II) has been used to guarantee a hard real time operation of the overall system.

HEAT ACCUMULATION CONTROL

The main parameter that defines the quality of the cladding process is the dilution. This parameter cannot be directly measured during the cladding process; however, there is a relationship between the melt pool width and the dilution. The correlation between the laser power and the clad properties (i.e. Dilution and width) has been determined from single images of the monitoring signal.

For Heat accumulation control strategy, the FPGA-based system provides a real-time signal of the melt pool geometry to implement a closed-loop control to manage the laser power in order to avoid heat accumulation in the part to be cladded. For this purpose, a measurement algorithm of the melt-pool is implemented in the FPGA in a three steps algorithm, as shown below:

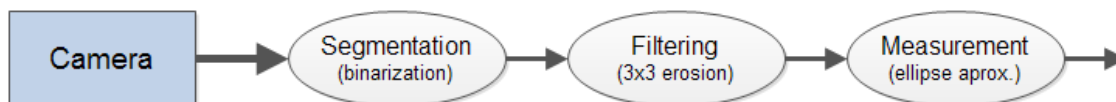

Figure 8: Measurement stream schematic.

1. Data sent by the Photonfocus CMOS camera are binarized (segmentation stage), transforming the image from grayscale to a binary.
2. The binarized image is eroded (filtering stage), erasing the noise with a size less than 3x3 pixels. This algorithm removes the incorrect saturated pixels from the image.

3. Finally, the data stream is processed by the geometrical module (measurement stage). This measurement algorithm is based on the calculation of the moments of inertia in order to estimate the best ellipse approximation for the melt pool footprint.

Figure 9 shows the melt pool image and measurement algorithm implemented for melt pool monitoring.

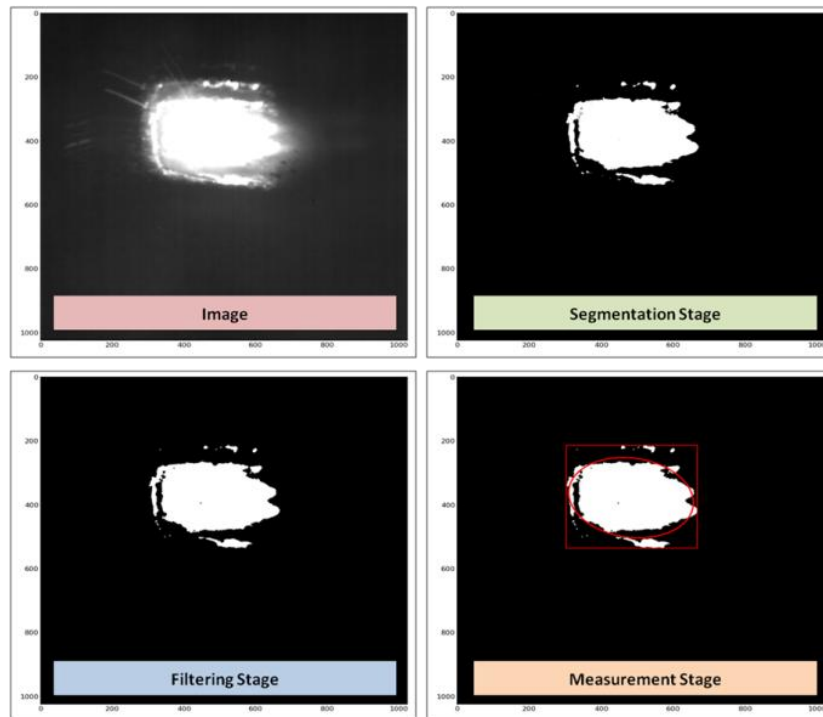

Figure 9. Image processing algorithm implemented in the FPGA controller.

The result of measuring the melt pool width is presented in Figure 10. The signals show frame per frame the calculated melt pool width while processing. The melt pool width provided by the monitoring system corresponds strongly to the seam width of the cross sections and has also strong correspondence with dilution.

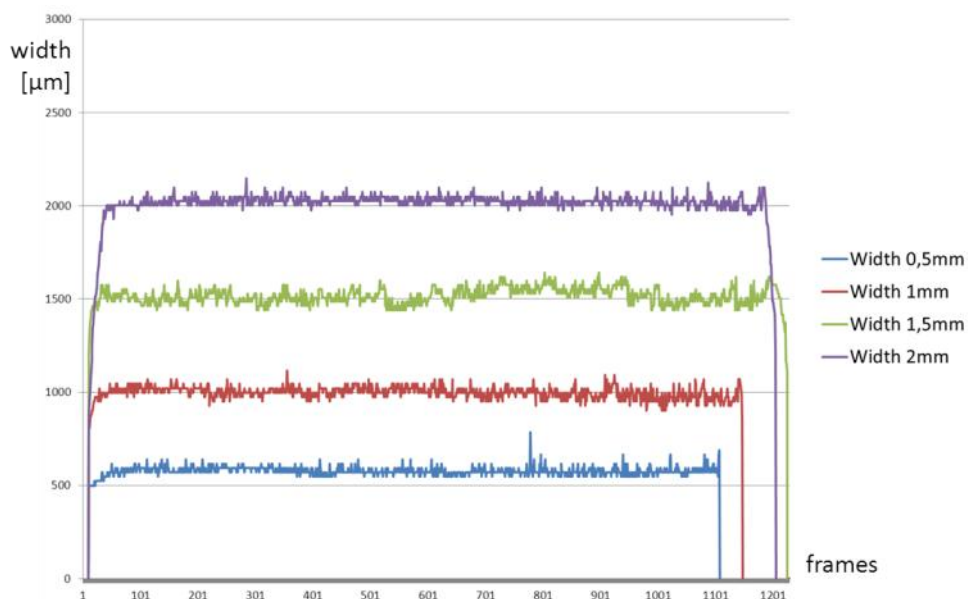

Figure 10 Signals of melt pool width.

From these experiments, the melt-pool depth (i.e. Dilution) was obtained from the analysis of different macrographs showing the cross-section of each clad track.

To control the heat input into the clad layer avoiding heat accumulation in the base material, it is a closed-loop system adapted for variable spot sizes has been develop. This system measures the geometry (e.g. width) of the melt pool during the cladding process.

The system uses a CMOS camera (in a coaxial setup with the laser beam) in combination with a FPGA development board. Images captured by the CMOS camera are transferred via CameraLink Base communication protocol to the control board. An analog input (0-10 V) of the laser power source is used to command the laser power applied to avoid heat accumulation in the part to clad.

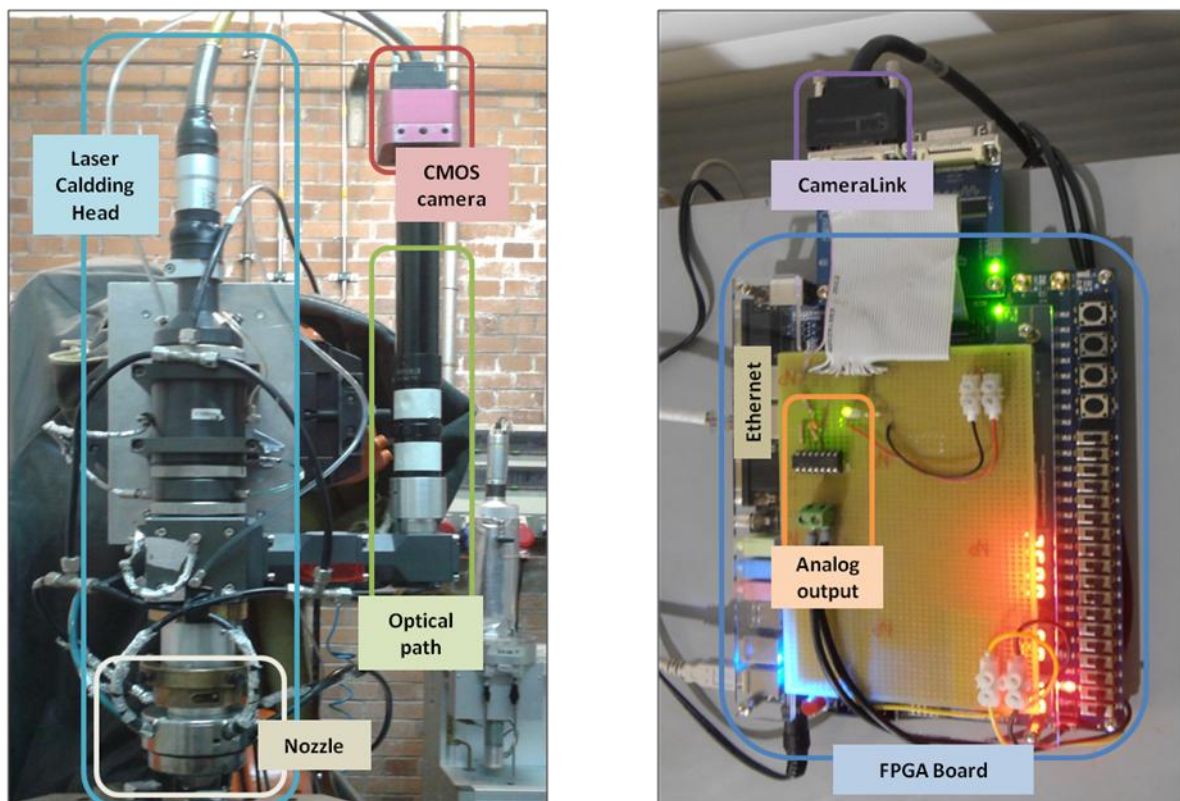

Figure 11 Testing laser cladding head and prototype of ALAS controller , b) FPGA hardware prototype of the ALAS controller.

VARIABLE OPTICAL PATH

Together with the Heat accumulation control, ALAS controller is capable to manage the position of the two movable lenses (L3 and L4) covering a magnification range of the zoom values from 1.2x to 2.5x. This movable system requires the synchronized movement of the two movable lenses:

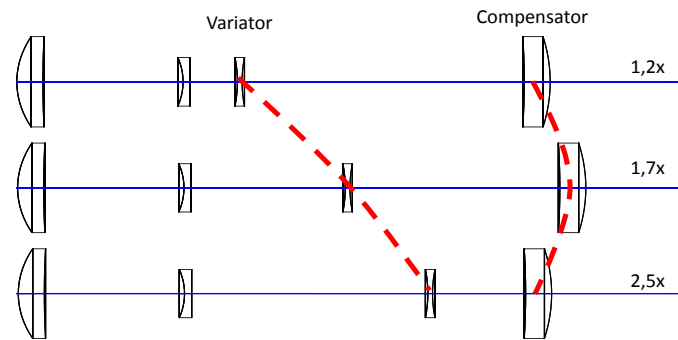

Figure 12. Synchronization of the movement of the movable lens.

Whole range of the magnification can be achieved in 4 seconds, but a linear zoom evolution requires 7.54 seconds (the slowest zoom variation requires 0.29s).

DESIGN AND MANUFACTURING OF THE ALAS CLADDING HEAD

According to the variety of applications in the project, the ALAS-prototype is designed and manufacturing as a modular cladding head with a zoom-module as the central element. This concept has the advantage that the module can be adapted to components like fibre-connectors, collimators and beam splitters. The zoom module is adapted via coupling flanges to these components. Due to the modular concept, the zoom module is capable to be adapted to other components by a simple exchange of the coupling flanges. The ALAS-zoom module has the external dimensions of 336mm x 202mm and 187mm. The weight of the ALAS head with lenses, drives, collimator and control is 12 kg. Besides, the weight of the COAX 8 nozzle –The nozzle used for validation and demonstration trials— is 2kg.

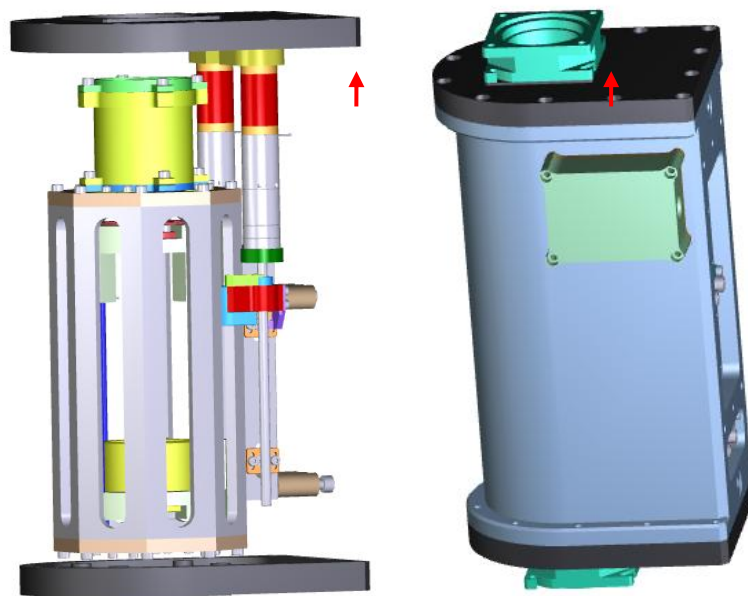

Figure 13. Scheme 3D of the ALAS prototype, interior and exterior of it.

Electrical and opto-mechanical elements have been integrated to compound the ALAS head prototype (Figure 14).

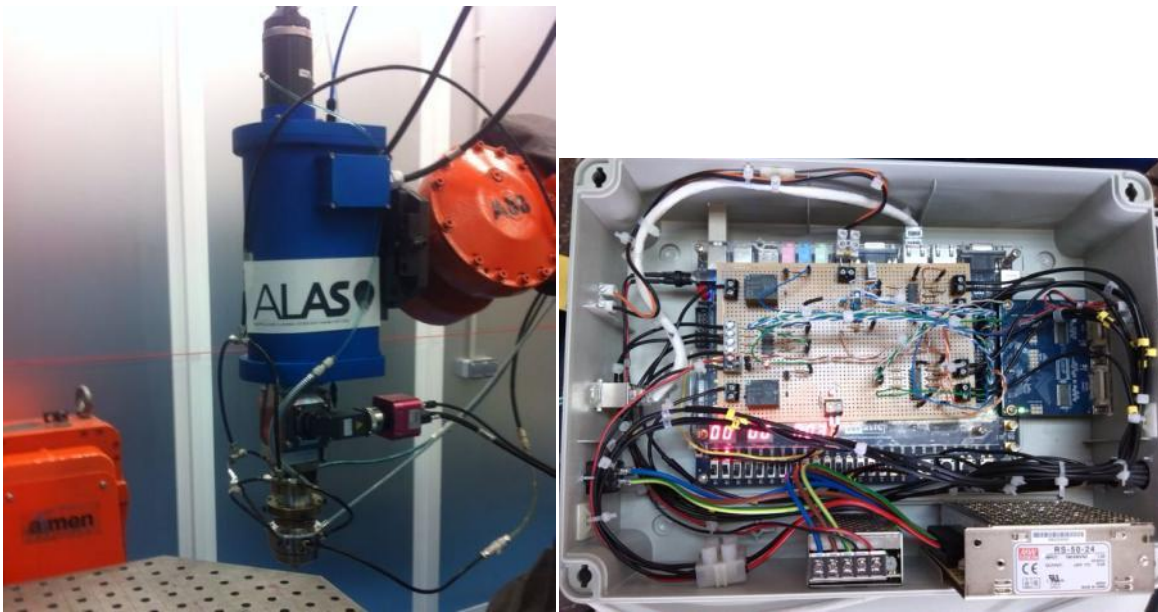

Figure 14. Final ALAS head prototype.

HIGH-LEVEL CONTROL SYSTEM

High-level control system establishes the link between the operator of the cladding cell and the RT-controller. The High-level control system has been developed to be intuitive for the cladding operator allowing an easy operability of the new cladding system. Communication between the user and the beam path is effected through a number of clear graphic user interfaces (GUI) or windows.

This user-friendly software enables the operator of the cladding cell to program a complex laser path only “sketching” the design of the complex part to repair, and setting the main parameters of the process, like initial laser power, process speed...

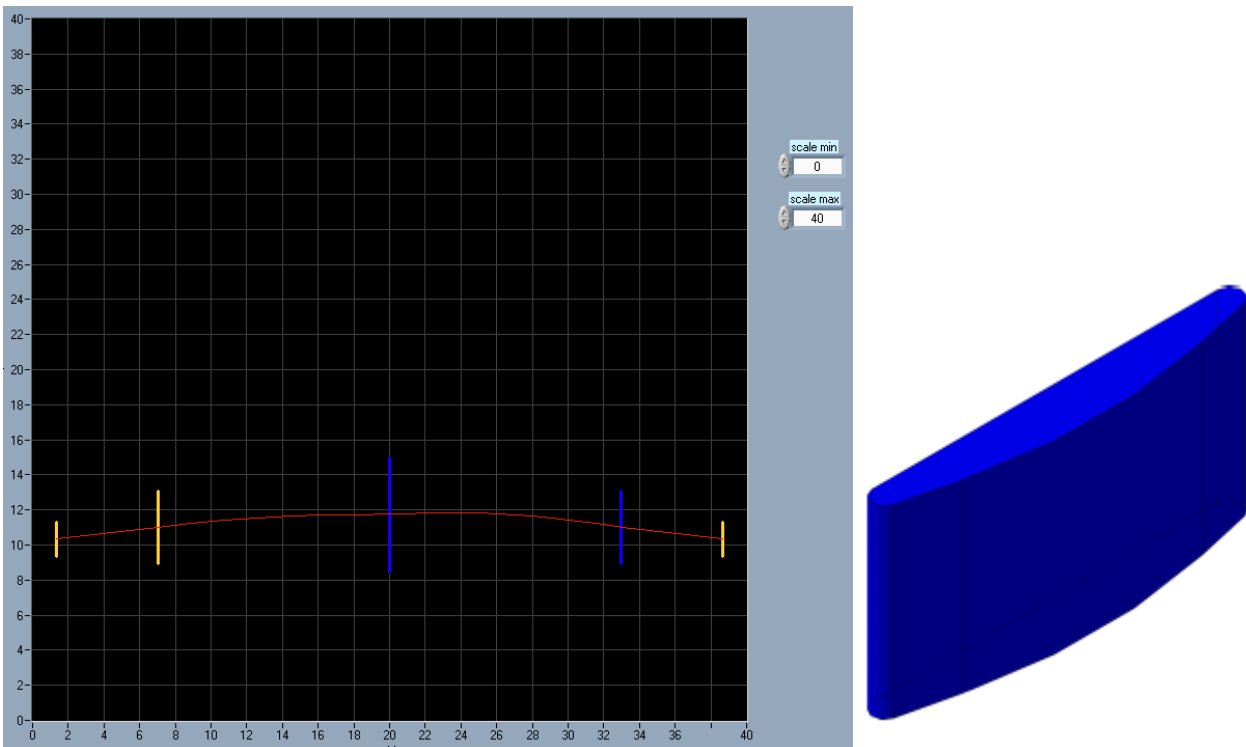

Figure 15. Example of the sketching of a complex graph by an operator using the High-level control system.

The connection between High-Level control system and RT-ALAS controller is based in TCP/IP socket connection, where the *ALAS controller* acts as the server, while the High-Level control system is the client (Figure 16). It enables the control of the system with a simple telnet connection, by using the human readable command protocol. Therefore, this communication protocol is used to configure and monitor ALAS controller in real time.

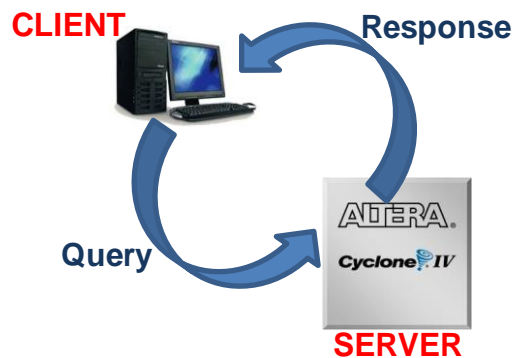

Figure 16. HMI-FPGA communication protocol

The control commands are programmed on-line (while the system is working), it enables having a complex routine with no extension limits (especially suitable for LMD, Laser Metal Deposition). The operator only has to define the path and the speed of the positioning system (e.g. robot), required to obtain the final shape of the track.

The HLCS (High-Level Control System) extracts automatically the routine of the optical lenses to adapt the beam size for a defined sketch and path, but it requires the generation of a correlation table that relates the width value with the parameterization of laser power and zoom value.

Finally the ALAS cladding system was integrated with all the elements that compounds a laser cladding cell (robot, laser, powder feeder, electronic devices,...).

LABORATORY VALIDATION TRIALS

First validation trials are focused in the validation of the beam size range to characterize the laser beam diameter at different magnification values. Thus, ALAS system was configured for different magnification values –i.e. x1.2, x1.5, x2.0, x2.5– and beam shape was analyzed for each magnification.

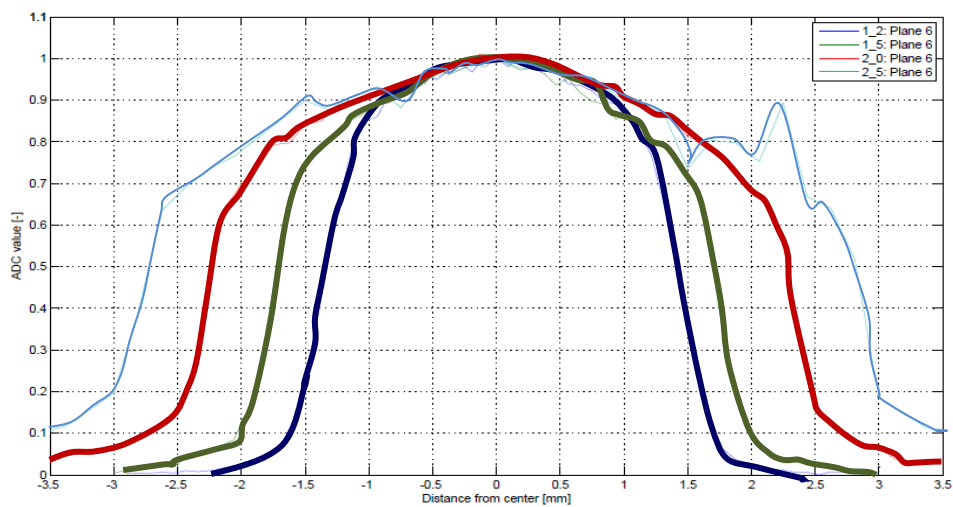

Figure 17. Cross-section of the beam size in all the magnification range.

Table 3 laser beam diameter at different magnifications.

Magnification	FWHM radius (mm)	FWHM diameter (mm)	FWHM Relation
1.2	1.35	2.7	1.20
1.5	1.70	3.4	1.51
2.0	2.25	4.5	2.00
2.5	2.90	5.8	2.58

Analyzing the graph it can be concluded that the ALAS head is working correctly because the real results of the variable zoom system are in consonance with the predefined in the requirements of ALAS prototype: from 2.7mm of diameter up to 5.8mm of diameter.

Once verified the correct operation of ALAS optical system, next trial was focused to check the correct operation of the variable optical zoom. Thus, it was programmed several trials modifying both laser power and zoom value.



Variable track:

- Starting: x1.2, 1000W
- Ending: x2.5, 3000W



Figure 18. Results obtained using the variable cladding head developed in ALAS project.

Regarding the validation of the operation of the variable cladding system, several variable cladding tracks were programmed modifying both laser power and zoom position on-the-fly.

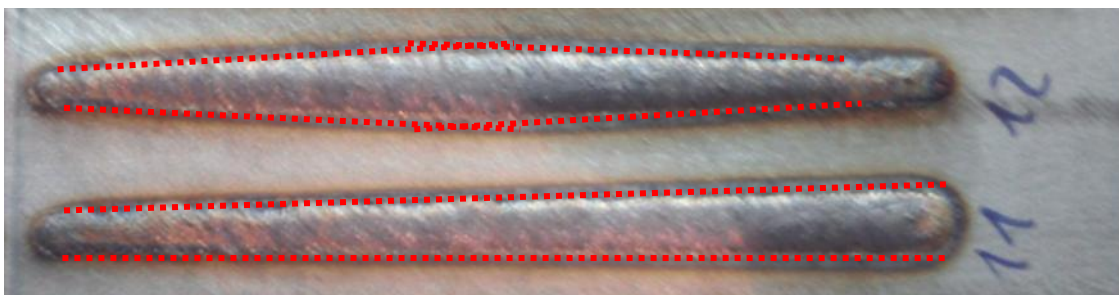

Figure 19. Different variable cladding tracks defined for the laboratory validation of the ALAS prototype.

All these trials evaluate the correct operation of the variable optical path to adapt the laser beam size to the requirements of the geometrical aspects of a complex shape in an easy way.

Finally, regarding the validation of the operation of the heat accumulation control, several trials with and without control of the laser power were programmed. The assessment of the heat accumulation control

application was done by defining a validation experiment by performing seven overlapped cladded tracks with and without power control for a specific zoom value.

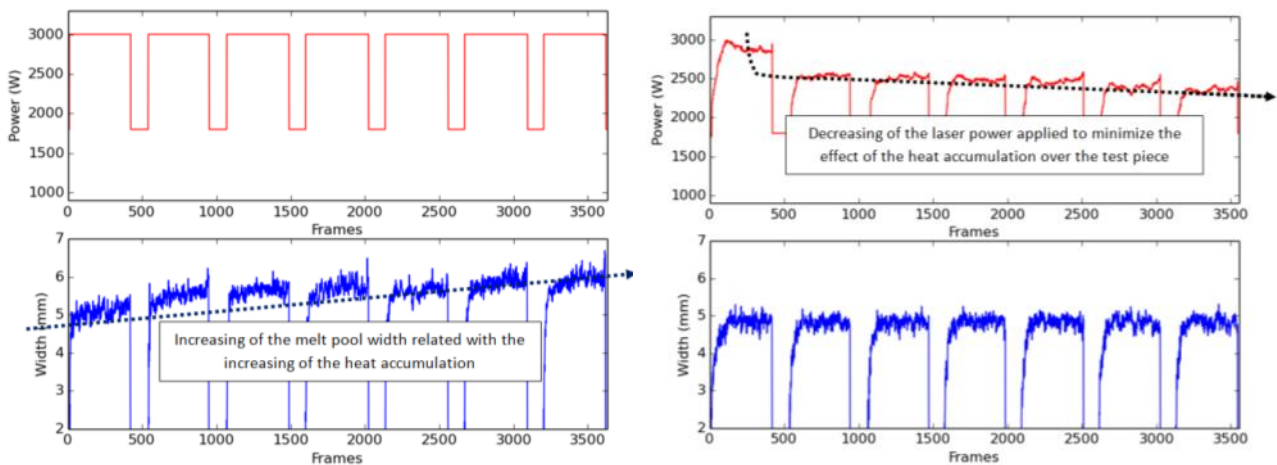

Figure 20. Comparison of applying a constant laser power value and a power control strategy to deal with the heat accumulation effect.

Metallographic examinations were done in order to characterize the cladding process and the properly operation of the RT-control system. Thus, Figure 21 shows the cross section of a sample cladded by using the Real-Time molten pool control strategy with an open-loop control strategy (up) or without laser control system (down). Analyzing the results obtained it is possible to extract how the RT-control system reacts to maintain the dilution of the laser cladding constant.

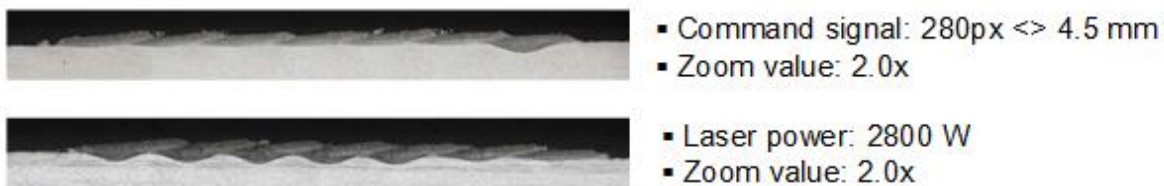

Figure 21. Metallographic comparison between close-loop control and a fixed laser power command.

PRE-INDUSTRIAL VALIDATION TRIALS

Pre-industrial validation trials are focused in the assessment of the ALAS cladding system in a pre-industrial environment. Two different applications, defined by end-users, were validated: Heat accumulation control applied to tubes and cladding of variable geometries.

Regarding the application of ALAS system applied for heat accumulation control in tubes, a spiral shape of the laser cladding track is programmed in the steel tube. The pitch of the spiral movement is programmed to have and overlap of 50% between consecutive laser cladding tracks.

When using a fixed laser power it is possible to observe that the melt pool size is growing when executing the laser cladding process. As the melt pool gets wider, the quality of the laser cladding track will be altered as well, due to different microstructural properties and an increasing in the dilution. Moreover one can observe that the higher heat input in the samples caused extra oxidation of the sample.

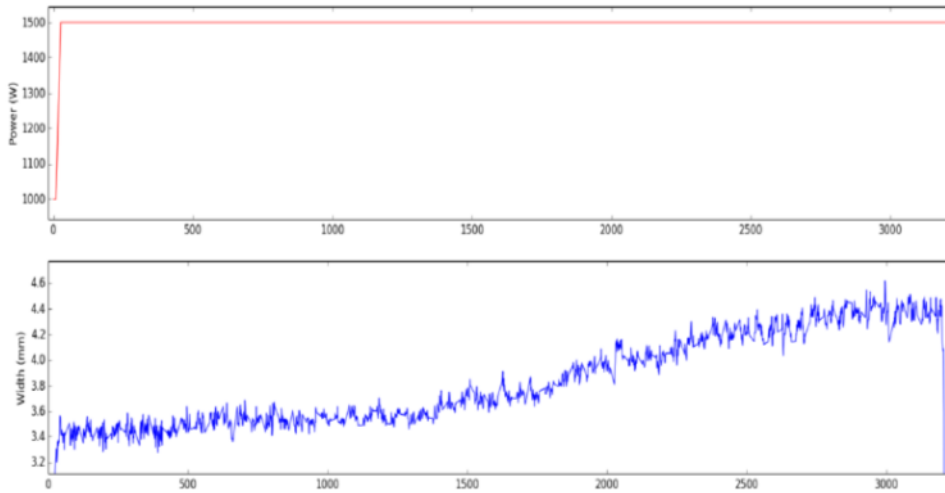

Figure 22. View on measured melt pool sizes during laser cladding process and their relation to the target width. Upon progress of the laser cladding process, a higher melt pool size is generated due to heat accumulation in the steel sample.

When comparing the laser cladding process on the same steel tube as used for the non-controlled experiment described above, now using the ALAS controller, one can observe that the camera image shows a steady size of the melt pool. Moreover one can observe that the applied laser power is decreasing as the process advances, resulting in a steady melt pool.

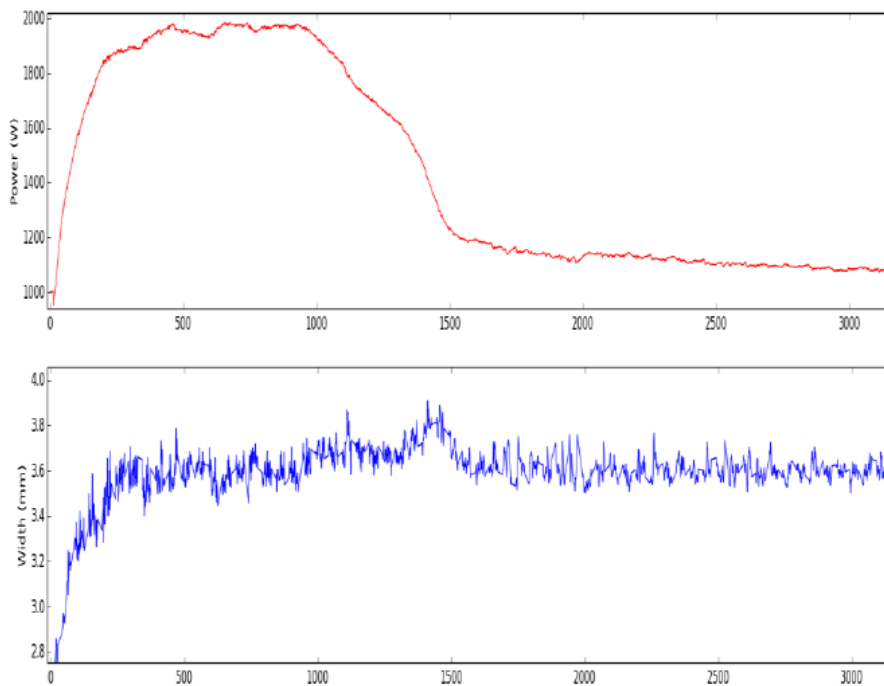

Figure 23. View on measured melt pool sizes during laser cladding process and their relation to the target width. Upon progress of the laser cladding process, a constant melt pool size is generated due to decrease of laser power.

Finally, regarding the application of ALAS system applied to the reconstruction of variable complex geometries, various multi-layer complex shapes have been manufacturing reconstruct using an additive laser-based manufacturing strategy. They include names as “banana”, “bended banana”, “diamond”, “hourglass” and “big-small” shapes.

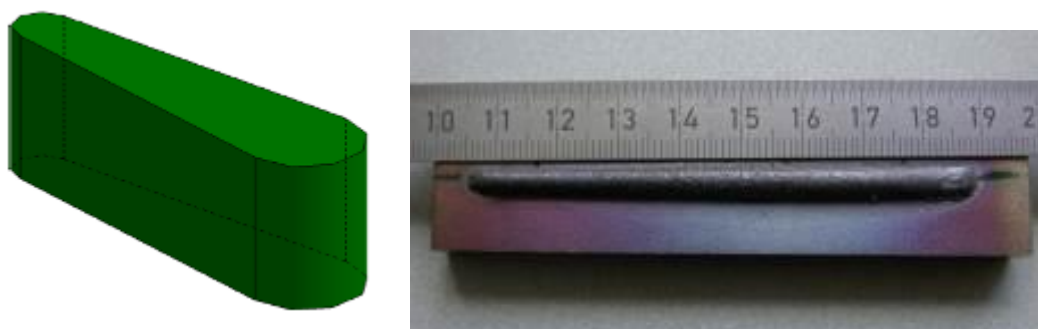

Figure 24. Left: digital drawing of right samples. Right: Picture of complex shape of sample 1, so-called big-small shape.

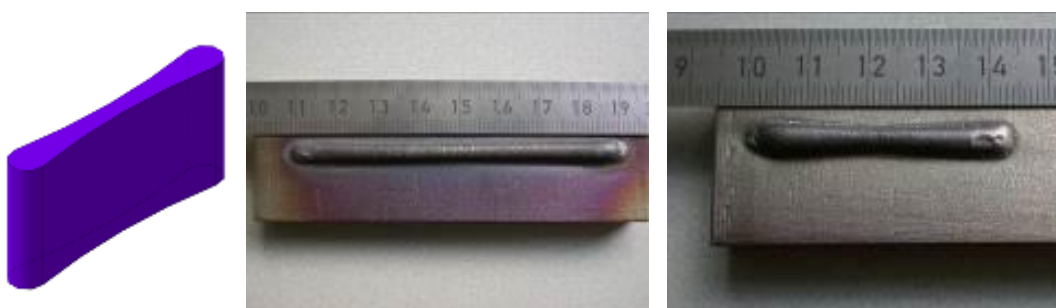

Figure 25. Left: digital drawing of hourglass shape. Middle: produced hourglass sample 2 of 80mm length, Right: produced hourglass sample 3 of 40mm length shape.



Figure 26. Left: digital drawing of Banana shape. Middle: produced piece sample 4 of 80mm length, Right: produced sample 5 of 40mm length shape.

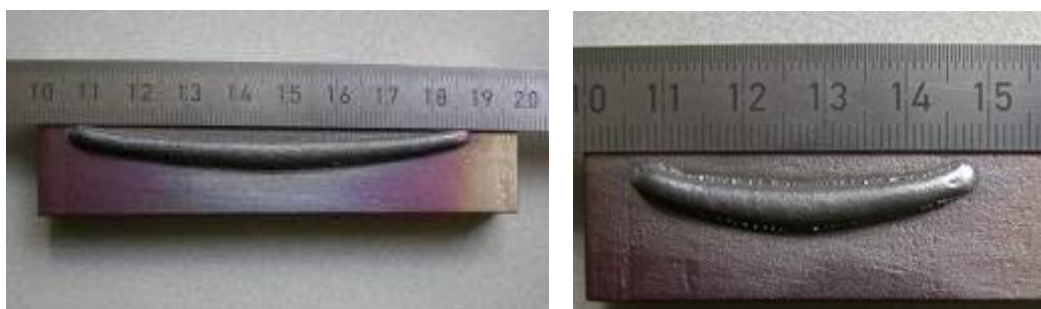

Figure 27. Left: produced bended-banana piece sample 6 of 80mm length, Right: produced bended-banana piece sample 7 of 40mm length.

All these set of trials at different conditions reveals that the ALAS prototype is a robust and versatile, flexible system, easy to implement in existing cladding cells. These set of tests is very valuable to introduce a new product like ALAS in a very competitive market, and show the costumers their potential benefit.

1.4 The potential impact

The ALAS project aims to shorten the gap between research and economy with latest research activities in the fields of optics, measurement and control, by providing an innovative, **adaptive laser cladding system with variable spot size** to end users. Thus, Europe's SMEs will be empowered to strengthen their global market position as the productivity will increase due to shortened setup times, flexibility gain and controlled quality. As a result of participation in this project, each SME expects to increase its market share with the completion of the project, introducing their products in a new industrial technology, laser cladding technology, which presents increased market share in next years.

The development of this innovative laser cladding head includes the develop of an adaptive optical path that will control the laser focus distance on the fly, it also has a user friendly interface in order to simplify the programming of this variable tracks and to develop a monitoring system which will control the laser parameters depending on the process status will ensure a steady process quality

The main features of the ALAS system are: simple interfacing with the operator, simple design adapted to complex geometries, real-time laser power control to avoid heat accumulation in the part to be processed, compact design that minimize the safety laser requirements of the traditional laser cells and provision to interface with the rest of elements of the laser cells.

The potential markets of application of the project results are:

- Companies working on repairing and coating,
- Different industries (heavy duty machinery, tooling, petrochemical, energy, manufacturing, aeronautical, naval, and transport),
- Laser manufacturers and laser equipment manufacturers.

The main application for laser cladding is repairing of parts with high added value (errors in manufacturing ratios, surface cracks, damages during service, prototype production, modifications, etc.).

To achieve this goal, some requirements need to be defined from the technical point of view, which should be met during the course of ALAS project, including:

- Definition of requirements of the variable zoom optics based on the characteristics of laser source
- Selection material used for coating or fabrication, definition of parameters of complex pieces.
- Develop the real time control system to control the laser power.
- Development a communications protocol between FPGA-Laser-control system
- Automation of the process
- Integration of all subsystems that compound the ALAS prototype (variable optical zoom, Real time control system, Human machine interface).

With the prototype fabricated in this project, the company can reduce process time and save money due the optimization of the cladding tracks and the decreasing, till to zero the non quality pieces. For that reason the profit of laser cladding equipment will be definitively increase.

Since the variable optical zoom optic for laser cladding developed in ALAS project is capable to adapt the optical magnification during the process in real time. It offers a solution to overcome the disadvantage of using multiple optics for one application. Other parties may be interested in using this or a similar zoom optic for their system. So, the expected impact for this result is 6-8 optics per year.

From technological, business and market viewpoints, significant benefits had been reached for the SMEs, including the following:

- Improvement of their innovation ability, benefitting by an integrate approach to problems thanks to a profound synergy between researchers having different skills and expertise in laser, laser cladding, laser system for material processing, expert in optical system, integrator of systems, expert in machine vision, mechanical design..

- Establishing collaborations with well-recognized and highly-reputed academic partners and RTD performers;
- Increasing their possibility of widening their market share;
- Opening new potential market applications and challenges.

ALAS consortium believes that the ideas and the achievements gained during this project will ensure in significant advances in several areas of the material processing field, especially in repairing complex geometries and re- manufacturing and fabricating complex 3D structures using laser cladding. The developed variable optical zoom together with the RT controls system and the High level control system, make more accessible the laser technology to other markets since not high skilled operator are required.

In order to extend the potential benefits of this idea to other fields in the wide world where laser technology is applied, a robust activity of dissemination and exploitation had been carried out.

Deliverable D7.7 “Dossier with all the publications made during the project “includes a list of these activities.

Main dissemination activities on the red:

Project website www.alasproject.eu

A Wikipedia page on the project and its results is available on:

https://en.wikipedia.org/wiki/Draft:European_Project_ALAS

A Short project video of ALAS prototype is available on:

<https://www.youtube.com/watch?v=X1jLhtK-JnA&feature=youtu.be>



Logo designed for ALAS project

Several dissemination activities are showing below:



Adaptative Laser Cladding System with Variable Spot Sizes

Main features of the ALAS system

- ➔ Simple interfacing with the operator
- ➔ Adapted to complex geometries, thanks to trackwidth variation
- ➔ Real-Time laser power control to avoid heat accumulation
- ➔ Compact design
- ➔ Provision to interface with the rest of elements of the laser cell

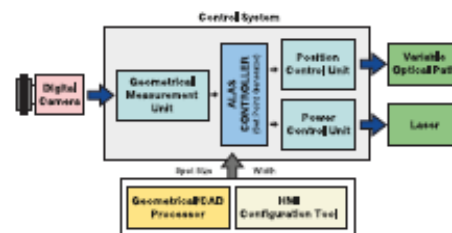

Technical objective

To develop an innovative laser cladding system, focused on repairing of complex geometries, and controlling the effect of heat accumulation, yielding a new fully automated and safe solution that will be very interesting for SMEs devoted to laser cladding applications as a service to a wide range of industrial sectors.

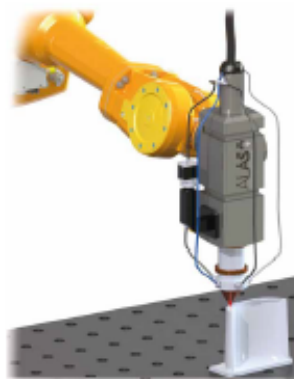

Main benefits for the industry

- ➔ Higher processing flexibility and productivity
- ➔ An increase of the market share for the end users
- ➔ Improved repairing sector competitiveness
- ➔ Improved the working conditions of operators
- ➔ New opportunities for high-technology products, like optical design, system solutions for laser cladding or other laser processes

ALAS is supported by the European Commission and puts together 5 SMEs located in 4 different countries, 3 RTD performers in 3 different countries which provide experts from different knowledge areas involved in the design and development of an adaptive laser cladding adapted to complex parts. The coordinator of the project is AMEN.



The research leading to these results has received funding from the European Union's Seventh Framework Programme (FP7/2007-2013) under grant agreement n° 315614.



Partners



Figure 28. Poster prepared for diffusion of the objectives of the ALAS project

ALAS Partners

AIMEN Technology Centre
Project coordination institution
Dr. M^a Ángeles Montealegre
amontealegre@aimen.es
www.aimen.es

Fraunhofer Institute for Laser Technology (ILT)
Dipl. Ing. Stefan Mann, Dipl. Ing. Peter Abels
www.ilt.fraunhofer.de

VITO Vision on technology
Dr. Filip Motmans
www.vito.be

TIC-LENS laserske tehnologije, d.o.o
Dr. Franc Lovec
www.tic-lens.com/sl

Sill Optics GmbH & Co KG
Dr. Annette Walter
www.silloptics.de

Talleres Mecánicos Comas S.L.U. (TMC)
Dr. Raimond Franch
www.tmcomas.com

PRECITEC KG
Dr. Markus Kogel Hollacher
www.precitec.de

NEOVISION s.r.o.
Ing. Petr Palatka, MSc.
www.neovision.cz

AIMEN Technology Centre

Relva, 27 A - Torneiros
36410 Porriño
Pontevedra - SPAIN
Phone: +34 986 344 000
Fax: +34 986 337 302
www.alasproject.eu



Partners



Project Coordination



Coordinator Office contact:

Dr. M^a Ángeles Montealegre
amontealegre@aimen.es
Phone: +34 986 344 000
Fax: +34 986 337 502



The research leading to these results has received funding from the European Union Seventh Framework Programme (FP7/2012-2014) under grant agreement n° 315614.

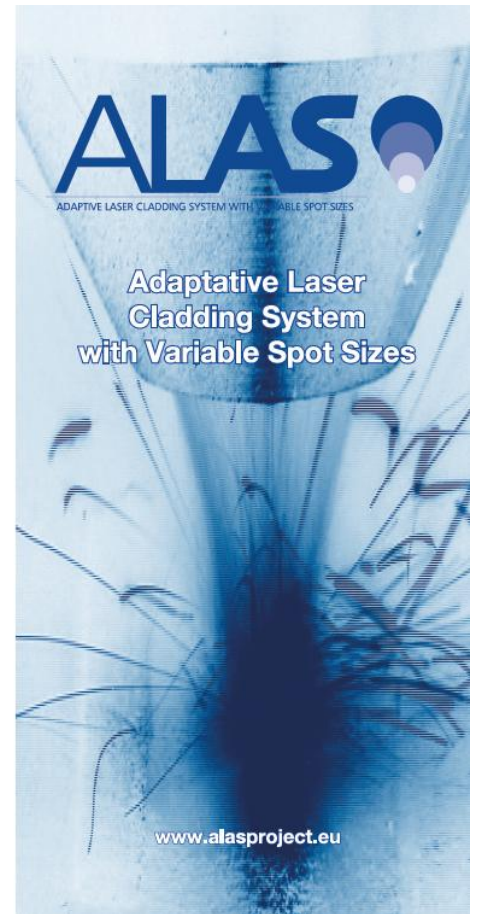



The research and innovation for SMEs (SILL, PRECITEC, NEOVISION, TIC-LENS, TMC) working in different sectors, namely: optical design (SILL), manufacturer and integrator of laser industrial systems (PRECITEC), machine vision solutions (NEOVISION), advanced repair laser services (TIC-LENS, TMC).

The SMEs will commercially exploit the project findings obtained by the 3 RTD performer partners (AIMEN, ILT, VITO) on new cladding head design.

The coordinator of the project is AIMEN

Project duration:
2 years

Starting project date:
September 1st, 2012

www.alasproject.eu

The research under this project has received funding from the European Community's Seventh Framework Programme (FP7 2007-2013) under Grant Agreement n° 315614.



Adaptative Laser Cladding System with Variable Spot Sizes

The ALAS project aims to develop an innovative laser cladding system, focused on repairing of complex geometries, and controlling the effect of heat accumulation, yielding a new fully automated and safe solution that will be very interesting for SMEs devoted to laser cladding applications as a service to a wide range of industrial sectors.

Main benefits for the industry:

- Higher processing flexibility and productivity
- An increase of the market share for the end users
- Improved repairing sector competitiveness
- Improved the working conditions of operators
- New opportunities for high-technology products, like optical design, system solutions for laser cladding or other laser processes

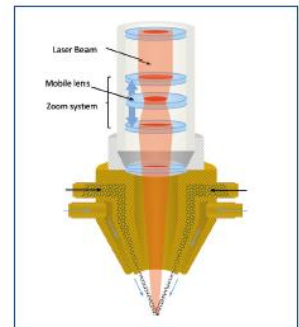

Main features of the ALAS system

- Simple interfacing with the operator
- Adapted to complex geometries, thanks to track width variation
- Real-Time laser power control to avoid heat accumulation
- Compact design
- Provision to interface with the rest of elements of the laser cell

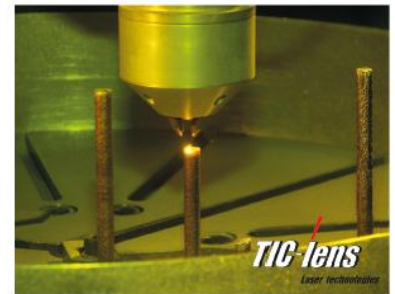
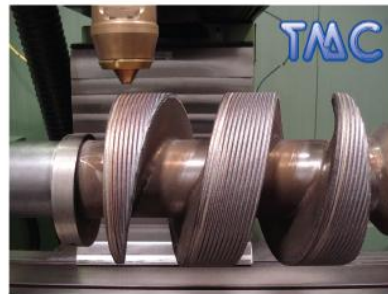

Figure 29. flyers printed to disseminate the main features of the ALAS project

ADAPTIVE LASER CLADDING SYSTEM WITH VARIABLE SPOT SIZES

ALAS
 ADAPTIVE LASER CLADDING SYSTEM WITH VARIABLE SPOT SIZES

MA, Montealegre, F. Vidal, S. Mann, P. Abels, F. Motmans, A. Walter, M. Kogel-Holbach, P. Palatka, R. French, F. Lovic. www.alasproject.eu

The ALAS project aims to develop an innovative adaptive laser cladding system with variable spot size which will include an adaptive optical system that will control the laser focus distance on the fly, a real-time FPGA system that will control the laser parameters to ensure a steady process quality and an user friendly interface in order to simplify the programming tasks. This system will constitute an efficient instrument for part repair with complex geometries and coating selective surfaces. This will be a significant step forward into the total industrial implementation of an automated industrial laser cladding process.

Control System

This control system aims :

- To develop a variable optical path.
- To develop a hardware control for the efficient control of the variable cladding process. The FPGA-based Real-Time control system is based on a Cyclone IV 4CE115 FPGA from ALTERA.
- To develop a closed-loop system adapted for variable spot sizes to control the heat input into the clad layer avoiding heat accumulation in the base material.
- To develop of a high-level control system, friendly with the operator

Simulation of optical system

Design of the zoom optics to allow the performing of clad tracks with variable spot size, 2.7-5.5mm.

Closed-loop system:
 Real-Time controller used to manage laser power to adjust the track width to the pre-programmed dimension avoiding heat accumulation

- Real time monitoring task based on a machine vision system
- Geometrical characterization of the molten pool
- Real time control system

Main benefits of the ALAS system

An adaptive laser cladding system with variable spot sizes has been developed yielding a new fully automated system focused on part repairing and coating of parts with complex geometries.

- ALAS system will constitute an efficient instrument for part repair with complex geometries and coating selective surfaces.
- Higher processing flexibility and productivity. The development of an adaptive cladding system based on laser processing will increase the productivity of remanufacturing/repairing sectors due to shortened setup times, flexibility gain and controlled quality.
- An increase of the market share for the end users.
- Improved repairing sector competitiveness. The use of the ALAS system will allow end-users to reduce repairing times, increasing their competitiveness.
- Improved the working operators' conditions.

Partners: aimen, Fraunhofer, vito, NEOVISION Industrial Vision Systems, TMC Lm. Comas, silt, TIG-LAS Laser Technology, PRECITEC

The research under this project has received funding from the European Community's Seventh Framework Programme (FP7 2007-2013) under Grant Agreement nº 315614.

Figure 30. Poster showed at ICALEO 2013

aimen **Acknowledgements**

Real-time laser cladding control with variable spot size

M. A. Montealegre, J. L. Arias, F. Vidal, J. Rodríguez, S. Mann, P. Abels, A. Walter, F. Motmans

amontealegre@aimen.es

This work has been carried out in the research project "Adaptive Laser Cladding System with Variable Spot Sizes (ALAS)", which has received funding from the European Community's Seventh Framework Programme (FP7 2007-2013) under Grant Agreement nº 315614.

ALAS **SEVENTH FRAMEWORK PROGRAMME**

www.alasproject.eu

Figure 31. Oral presentation at Photonic West-2014

Use and dissemination of foreground

LIST OF SCIENTIFIC (PEER REVIEWED) PUBLICATIONS, STARTING WITH THE MOST IMPORTANT ONES										
N O.	Title	Main author	Title of the periodical or the series	Number, date or frequency	Publisher	Place of publication	Year of publication	Relevant pages	Permanent identifiers (if available)	Is/Will open access provided to this publication?
1	Adaptive Laser Cladding system with variable spot sizes	MA. Montealegre, F.Vidal, S.Mann, P. Abels, A. Walters, M.Koger-Holacher, P. Palatka, R. Franch, F. Lovec	Proceedings ICALEO 2013 International congress on applications of lasers and electro-optics. pags 950-954		LIA - Laser Institute of America		13/10/2013	950-954		No
2	Real-time laser cladding control with variable spot size	JL. Arias, MA. Montealegre, F.Vidal, J. Rodríguez, S.Mann, P. Abels, Filip Motmans	SPIE proceedings		SPIE proceedings volume 8970		06/03/2014	15 pages	http://spie.org/Publications/Proceedings/Paper/10.1117/12.2040058	No

LIST OF DISSEMINATION ACTIVITIES

N O.	Type of activities	Main leader	Title	Date/Period	Place	Type of audience	Size of audience	Countries addressed
1	Website/Applications	AIMEN	Official ALAS project website	20/10/2012	www.alasproject.eu	SC (HE, R) I, CS	4000	EU/ international
2	Website/Applications	AIMEN	Publication of ALAS reference in Partner's website	10/10/2012	www.aimen.es http://www.aimen.es/index.php?option=com_content&task=view&lang=en&id=272	SC (HE, R) I, CS	6000	EU/ international
3	Website/Applications	VITO	Publication of ALAS reference in Partner's website	14/03/2013	www.lcv.be	SC (HE, R) I, CS	10000	EU/ international
4	Website/Applications	FHG	Publication of ALAS reference in Partner's website	01/10/2012	www.ilt.fraunhofer.de	SC (HE, R) I, CS	4000	EU/ international
5	Website/Applications	SILL	Publication of ALAS reference in Partner's website	14/10/2012	www.SILLOptics.de	SC (HE, R) I, CS	11000	EU/ international
6	Website/Applications	PRECITEC	Publication of ALAS reference in Partner's website	05/10/2012	www.PRECITEC.de	SC (HE, R) I, CS	15000	EU/ international
7	Website/Applications	NEOVISION	Publication of ALAS reference in Partner's website	05/10/2012	http://www.NEOVISION.cz/cz/sols/alas.html	SC (HE, R) I, CS	2000	EU/ international

8	Website/Applications	TMC	Publication of ALAS reference in Partner's website	13/11/2012	http://www.tmcomas.com/en/english-participation-in-eu-research-project-alas-www-alasproject-eu/	SC (HE, R) I, CS	2500	EU/ international
9	Website/Applications	TIC-LENS	Publication of ALAS reference in Partner's website	13/11/2012	www.TIC-LENS.com	SC (HE, R) I, CS	2500	EU/ international
10	Website/Applications	AIMEN	Articles published on the website of AIMEN	10/09/2012	http://www.aimen.es/index.php?option=com_content&task=view&lang=en&id=272	SC (HE, R) I, CS	4500	EU/ international
11	Articles published in the popular press	AIMEN	Reparación a punta de láser	13/12/2012	http://www.abc.es/local-galicia/20121213/abci-reparacion-laser-porrio-201212131036.html ABC Galicia	SC (HE, R) I, CS Media	3500	Spain
12	Article published in the popular press	AIMEN	El Centro Tecnológico AIMEN trabaja en el desarrollo de un sistema innovador de reparación por láser	2/6/2014	News in AIMEN technology bulletin nº 20	I, CS	400	Spain
13	Article published in the popular press	AIMEN	AIMEN coordina un consorcio europeo para el desarrollo de un sistema innovador de reparación por láser	14/12/2012	http://xornal21.com/not/2891/aimen-coordina-un-consorcio-europeo-para-el-desarrollo-de-un-sistema-innovador-de-reparacion-por-laser	SC (HE, R) I, CS Media	500	Spain
14	Article published in the popular press	AIMEN	El Centro Tecnológico AIMEN trabaja en el desarrollo de un sistema innovador de reparación por láser	13/12/2012	Innovamás- revista de innovación	SC (HE, R) I, CS Media	350	Spain
15	Poster /scientific event	AIMEN	Adaptive laser cladding system with variable spot sizes	6-10/10/2013	ICALEO- International Congress on Applications of Lasers & Electro-Optics	SC (HE, R), I	1000	International
16	Website/Applications website	AIMEN	Results of first periodic report	13/06/2013	http://cordis.europa.eu/result/rcn/143011_de.html	SC (HE, R), I	500	EU

17	Oral presentation to a scientific event	AIMEN	Presentation of the results	25/09/2014	X Conference on Materials Processing Laser Technology Porriño-Spain	SC (HE, R) I	200	EU
18	Website/Applications	AIMEN	Articles published in news on the website of AIMEN	30/09/2014	http://www.aimen.es/index.php?option=com_content&task=view&id=651&Itemid=100&lang=en	SC (HE, R) I, CS	2000	EU
19	Oral presentation to a scientific event	AIMEN and SILL	Real-time laser cladding control with variable spot size	1-6/ 02/ 2014	Photonics West- San Francisco- http://spie.org/x106299.xml	SC (HE, R) I,	11000	International
20	Oral presentation to a scientific event	AIMEN and SILL	Development of an adaptive laser cladding system with variable spot size	19-24/10/2014	ICALEO 2014	SC (HE, R), I	10000	International
21	Flyers	AIMEN	Leaflet of the project: "ALAS- Adaptive laser cladding head with variable spot size"	10/11/2012	Several dissemination events	SC (HE, R), I, CS	500	EU/International
22	General Poster	AIMEN	Main objectives and features of ALAS project	10/11/2012	Several dissemination events	SC (HE, R), I, CS	1000	EU/International
23	Exhibition	FHG	General poster and Flyers	7-9/05/2014	AKL-2014	SC (HE, R), I	400	EU
24	Exhibition	VITO	General presentation of the ALAS project	20-22 /03/2014	MTMS fair in Brussels 20-22 Marzo	industry (mainly)	20	Mainly Belgium
25	Exhibition	VITO	General presentation of the ALAS project	April-2014	Industrial laser Event- Universiteit Twente	industry (mainly the Netherlands)	100	EU
26	Presentation	VITO	Presentation laser cladding to SME, including part on ALAS project	04/06/2013	Tilburg, The Netherlands	Industry	2	The Netherlands
27	Publication SILL newsletter	SILL	Participation in EU research project ALAS	May 2014	Wendelstein, Germany, mailing to customers	Industry	1010	worldwide

28	Press releases	SILL	Adaptative Laser cladding system with variable spot size	March 2014	Fuerth,Germany http://www.lef.info/	SC (HE, R), I	80-100	Germany
29	Fair- exhibition	TIC-LENS	Objectives of ALAS project	16-19/April/2013	12 th Forma tool Professional Fair Celje showground http://www.ce-sejem.si/en/fairs/2013/specialised-trade-shows/12th-forma-tool	Industry	11000	EU
30	Poster in Fair Exhibition	TMC	Objectives of ALAS project	21-23/05/2014	ITSC 2014, International Thermal Spray Conference, Barcelona https://www.dvs-ev.de/call4papers/index.cfm?vid=69	SC (HE, R), I	10000	EU
31	Poster in Fair-exhibition	TMC	Main features of the ALAS project	30 Sept to 3 Oct/2014	Expoquimia- Barcelona http://www.expoquimia.com/en/home	SC (HE, R), I	38000	EU
32	Exhibition	TMC	Objectives of ALAS project	30 Sept to 3 Oct/2014	Expoquimia- Barcelona http://www.expoquimia.com/en/home	SC (HE, R), I	38000	EU
33	Fair	NEOVISION	Main features of the ALAS project	7-11/10/2013	International Engineering Fair (MSV2013) in Brno.	I	75000	EU
34	Seminar	NEOVISION	Modern methods of pattern recognition and image information processing 2014	24/09/ 2014	Technical University in Liberec and Preciosa, a.s. Liberec, Czech Republic	SC (HE, R), I	50	Czech Republic
35	Presentation	NEOVISION	Industrial measuring and navigation systems based on machine vision	28/08/ 2014	Non-destructive testing of components in power production systems using robotics	SC (HE, R), I	30	Czech Republic
36	Wikipedia page	FHG	Wikipedia page for the project and it results	29/08/14	https://en.wikipedia.org/wiki/Draft:European_Project_ALAS	SC, He, R, I, CS	2000	EU/International
37	Film	VITO	Five minutes Video	29/08/14	https://www.youtube.com/watch?v=X1jLhtK-JnA&feature=youtu.be	SC, He, R, I, CS	1500	EU/International

Type of Exploitable Foreground	Description of exploitable foreground	Confidential Click on YES/NO	Foreseen embargo date dd/mm/yyyy	Exploitable product(s) or measure(s)	Sector(s) of application	Timetable, commercial or any other use	Patents or other exploitation (licences) or IPR	Owner & Other Beneficiary(s) involved
Commercial exploitation of R&D results	Variable Optical path	yes		Specific combination of Optical elements to integrated in Laser equipments	Laser equipment manufacturers.	End of 2015	The variable optical path alone is hard to protect by a patent.	SILL
Commercial exploitation of R&D Results	Real time control system	Yes		Control system to be integrated in Laser equipments	Laser equipment manufacturers	End of 2015	Copyright	Joint ownership by SILL, PRECITEC, NEOVISION
Commercial exploitation of R&D Results	High-level control system	Yes		Control system for the integration of ALAS system	Laser manufacturers, and laser equipment manufacturers.	End of 2014	Up to now no actions with respect to IPR planned	PRECITEC
Commercial exploitation of R&D Results	ALAS prototype	No		To develop cladding (repairing and coating) solutions for several sectors.	Heavy duty machinery, tooling, petrochemical, construction, manufacturing, aeronautical, naval and transport.	2016	Possible patent of the process data for the different powder materials and basic materials	Joint ownership by TIC-LENS, TMC and NEOVISION

Variable Optical path: Variable optical design developed to obtain all the magnification range of the laser beam size. This result will be exploitable by SILL as optical developer of the cladding head.

The zoom optic for laser cladding is capable to adapt the optical magnification during the process in real time. It offers a solution to overcome the disadvantage of using multiple optics for one application. The zoom optic is part of the ALAS cladding head, which is planned to be developed to a commercially sold system by PRECITEC. As the adaption of HLCS and other modules has to be evaluated by PRECITEC, SILL cannot add a concrete timetable for the exploitation here. At this time the potential impact cannot be predicted, as the sales department from PRECITEC has to discuss internally and with potential customers.

In addition to that, the Zoom Optic can easily be adapted to other input parameters, like other wavelengths or fiber diameters.. These modified Zoom Optics might lead to an additional impact of a few optics per year.

For the current zoom optic there will be no or minor research necessary. Minor research may be related to test the zoom optics with other lasers, beam diameters, or qualifying additional parameters, if requested.

Similar zoom optics can be developed with the help of the gather background information from ALAS, with moderate effort and lead time.

Up to now no actions with respect to IPR planned.

Real-Time control system: Real-Time controller capable to implement a closed-loop control to manage the laser power in order to avoid heat accumulation in the part to be cladded. This result will be exploitable by NEOVISION due to its knowledge in machine vision and electronics.

Up to now no actions with respect to IPR planned

Adaptive cladding head: Modular cladding head integrated with a zoom-module and a Real-Time controller that manages both the variable optical path and the laser power, in order to enable building complex cladding geometries with good quality tracks. This result will be exploitable together by PRECITEC (as laser system manufacturer), NEO (as electronic integrator) and SILL (as optical developer). These partners together have the knowledge for the manufacturing of an adaptive cladding head integrated with a RT-controller system and adaptive optical zoom.

According to results ownership allocation, PRECITEC is entitled to exploit the adaptive cladding head.

Up to now no actions with respect to IPR planned

High-Level control system: Human-Machine-Interface that allows the interaction between the operators of the system with the Real-Time controller. This HMI is designed to be intuitive for the cladding operator allowing an easy operability of the new cladding system. This result will be exploitable by PRECITEC as laser equipment manufacturer.

According to results ownership allocation, PRECITEC is entitled to exploit the high level control system. The High Level Control System will be integrated into a LAM machine in order to use the essential process information (process input parameters and process monitoring results) to control the final quality of the LAM process. The adaptation of the high level control system and its interfacing capabilities to PRECITEC devices will be evaluated. The capability will be discussed with potential end customers and machine integrators. The research and work necessary is to proof the industrial readiness of the High Level control system. The potential of the integration of the High Level Control system in LAM machines will be discussed with the sales division at PRECITEC to get a rough estimation about the potential numbers in sales and the time horizon.

Up to now no actions with respect to IPR planned

ALAS prototype: Parameterization of the ALAS prototype used in the validation in real working conditions. This result will be exploitable by NEO and end-users (TIC-LENS and TMC) because they will be involved in the system parameterization acting as system integrator and end-users with experience in laser processing. As a potential buyer of the equipment TMC intend to exploit the software in the near future. Regarding IPR, could be patenting the process data for the different powder materials and basic materials. Further research is welcome on the Optimization of laser head (to reduce the size of the head)

Optimization software (program adapted to the user). At this moment, there is no owner that is fully decided to commercialize the system, so the potential for our co-owned R5 foreground is unknown.