



Publishable report

Seasonal thermal energy storage in existing buildings.

EINSTEIN project:
"EFFECTIVE INTEGRATION OF SEASONAL THERMAL
ENERGY STORAGE SYSTEMS IN EXISTING BUILDINGS"

January 2012 – December 2015

PROJECT WEBSITE: www.einstein-project.eu



ACKNOWLEDGMENT: This Project has been financed by the European Commission.
Grant agreement no.: 284932

TABLE OF CONTENTS

1.- EXECUTIVE SUMMARY.....	3
2.- DESCRIPTION OF PROJECT CONTEXT AND OBJECTIVES	5
2.1.- PROJECT CONTEXT	5
2.2.- OBJECTIVES	7
3.- MAIN SCIENTIFIC AND TECHNICAL RESULTS AND FOREGROUNDS	8
3.1 The Pilot Plant in Ząbki, Warsaw.....	8
3.2.- The Pilot Plant in Bilbao, Spain.	13
3.3.- Use of Heat Pumps in combination with STES in low temperatures. The Polish pilot plant case.	20
3.4.- Design and implementation of the EINSTEIN control system.....	21
3.5.- Developed tools and Design Guidelines.	23
3.5.1.- Evaluation tool to assess the cost effectiveness of the different retrofitting strategies.....	24
3.5.2.- Decision Support Tool for STES design and estimation of costs	25
3.5.3.- Design guidelines for STES tanks.....	26
3.5.4.- Design guidelines for STES systems	27
3.6.- Technical, economic and financial feasibility assessment of STES systems for building retrofitting.....	28
3.7.- Training	32
4.- POTENTIAL IMPACT. MAIN DISSEMINATION ACTIVITIES. EXPLOITATION OF RESULTS.	34
4.1.- POTENTIAL IMPACT.....	34
4.2.- MAIN DISSEMINATION ACTIVITIES.....	37
4.3.- EXPLOITATION OF RESULTS.....	38
5.- PROJECT PUBLIC WEBSITE. CONTACT DETAILS	42

1.- EXECUTIVE SUMMARY

Einstein project has as main objective, to develop, to evaluate and to demonstrate that **low energy heating systems** based on solar thermal energy combined with **Seasonal** Thermal Energy Storage (STES) concept and coupled with **heat pumps** are **feasible** from a technical and **economic** point of view. For this purpose, two demo STES installations have been designed, built and monitored in **Warsaw and Bilbao** and at the moment and during at least **two more years**, both installations will be **monitored and regularly checked** by the partners responsible for them.

Apart from both demo installations in operation, Einstein project has provided other outputs:

- The development, construction, installation and operation of a **new heat pump** that allows working with higher temperatures than conventional heat pumps, suitable to be integrated with STES systems
- The development of a **software evaluation tool** for the most cost-effective **building retrofitting framework definition** (public software tool).
- The development of a **Decision Support Tool** for selection, preliminary design and evaluation of STES systems in existing buildings (public software tool).
- **Design guidelines of STES systems** for future stakeholders/promoters/users of STES technology (public deliverable). It is a public report in which the key aspects that should be taken into account for a successful design of a STES system are explained
- **Learned lessons** document that summarizes the experiences and knowledge acquired by the consortium **from both demos** for providing **support to future new STES installations**.
- **Project webpage**: <https://www.einstein-project.eu> with a public section to acquire public tools and reports developed by the project, training materials, etc.
- **Training material in STES** technology at three different levels: for **educators, technical staff** and for **decision makers** in seven languages of the consortium.
- An **advance over the state of the art** regarding **STES tanks construction**: a report on "Modular construction description systems for STES technologies" has been developed, which is the first available English report that describes the materials, methods and

procedures to realize a STES. With this report the building industries receive the ability to understand the construction of seasonal storages (TTES, PTES and BTES) to derive the design of a single STES and to perform the realization and building process of a single STES. Furthermore, the implemented R+D activities have shown that it is possible to build STES systems with lower specific costs than the older pilot plants of similar sizes.

- Last but not least, **business models for ESCO and no ESCO companies** (public, customer cooperatives etc) to exploit STES systems

2.- DESCRIPTION OF PROJECT CONTEXT AND OBJECTIVES

2.1.- PROJECT CONTEXT

In recent years, European Union policy of sustainable development, concentrated on reducing energy consumption, environmental degradation and increasing share of renewable energy sources. In 2007 The European Council adopted new environmental targets, even more ambitious than those of the Kyoto Protocol. The plan included the so-called “three 20 targets”:

- To reduce emissions of greenhouse gases by 20% before 2020, taking 1990 emissions as the reference;
- To increase energy efficiency in order to save 20% of EU energy consumption by 2020;
- To reach 20% of renewable energy in the total energy consumption in the EU by 2020.

These are the main challenges for Europe in the nearest future and as residential and commercial buildings are responsible for about 40% of total energy consumption in EU, this is where the biggest opportunities for improvements can be found (Figure 1).

First important step in reducing overall energy consumption of buildings is to design and construct new buildings in zero-net-energy standard. Next step is retrofitting old buildings in order to reduce their energy demand. Potentially most significant reduction can be achieved by adding or improving envelope insulation, replacing windows with highly efficient ones and replacing old heating systems.

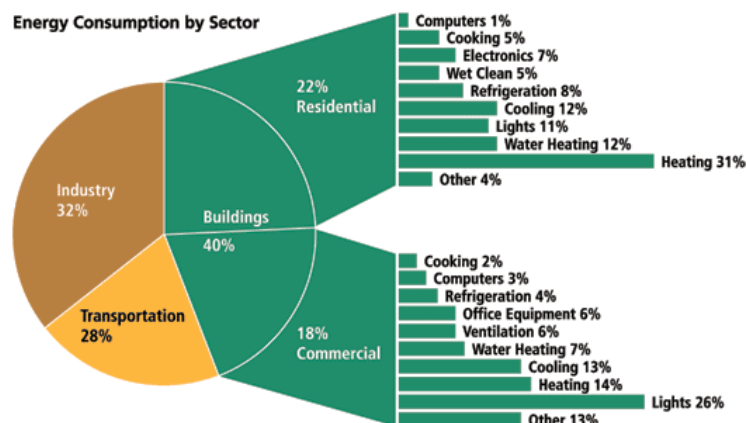

Figure 1. Energy Consumption by Sector in EU

Implementation of energy storage systems, together with smart ICT controls, make energy peak shaving possible at building level, increasing its energy efficiency. This effect can be amplified in the case of extending the system from one building to, for example, a small district. Coupling such solution with less predictable renewables, makes even more sense, as it reduces also primary energy demand. The EINSTEIN project addresses above issues and provides measurable, sustainable solutions, to reduce primary energy consumption of existing buildings. An integrated system, based on energy provided by renewable energy sources and seasonal energy storage has been developed. It is of great importance, to understand such systems purpose in a broader, socio-economical context. In contrast to most research programs, the aim of EINSTEIN, was not only an evaluation of various technical aspects of ready-to-work installation, but also, even more challenging, socio-economic aspects of preceding construction works. Potentially interesting business models were analysed and described. EINSTEIN project approach is the combination of efficient solar collectors system, seasonal water heat storage and existing building(s). Also such components as: intelligent ICT systems for energy management, dedicated heat pump and methodology for trenchless technology of laying pipelines between system elements and buildings were included.

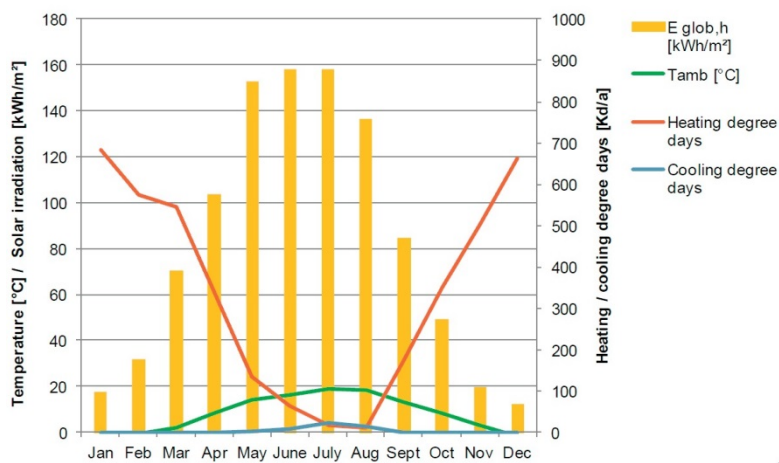

Figure 2. Monthly values for solar irradiation ($E_{glob,h}$), ambient temperature (T_{amb}), heating and cooling degree days for Warsaw according to Meteonorm

Heat absorbed by solar collectors during sunny months is accumulated inside the seasonal thermal energy storage tank – the “heart” of the system. During autumn and winter period heat from storage is utilised for space heating purposes. This process can be observed in the Figure 2, where heating, cooling degree days and solar irradiation in the function of months was shown.

Highly efficient, dedicated heat pump operating in higher than usual temperature range (suitable for high temperature radiator space heaters), enables to discharge heat from STES tank, even when temperature inside STES is not high enough for direct heating. Developed energy management system ensures that the utilization of non-renewable fuel is reduced to the lowest possible level.

2.2.- OBJECTIVES

The overall objective of the project is the development, evaluation and demonstration of a low energy heating system based on Seasonal Thermal Energy Storage (STES) systems in combination with solar thermal energy and heat pumps for space heating and domestic hot water (DHW) requirements to be used in existing buildings to drastically reduce primary energy consumption (primary energy savings up to 70% compared to conventional existing thermal systems).

The integration between Seasonal Thermal Energy Storage (STES) system and heat pumps is one of the main breakthroughs of the EINSTEIN project. STES systems are known in Northern Europe and heat pump technology is known and used all over the world, but the integration between these two systems is a novelty (there is a new small plant in Crailsheim, Germany, 2016). A heat pump that is suitable to be integrated with STES systems is not commercially available, mainly due to high temperatures that are required in the low temperature source of the heat pump.

This goal will be achieved by the following specific objectives:

- Technological developments for STES systems adaptation for existing buildings and integration with the built environment
- Development of a novel, high-efficiency, cost-effective and compact heat pump suitable for existing buildings and optimized for higher temperature heat sources such as STES systems
- Development of new business and cost models which consider the entire life cycle of a building and incorporate the benefits of reduced operating costs; a decision support tool will help the planners to find the best technology to install in each particular case
- Development of integrated building concept. As cost-effectiveness is one of the main aspects to be considered in building retrofitting, a methodology and a software tool for most cost-effective global energy intervention framework definition for building retrofitting will be developed

3.- MAIN SCIENTIFIC AND TECHNICAL RESULTS AND FOREGROUNDS

3.1 THE PILOT PLANT IN ZĄBKI, WARSAW.

In order to validate the results of EINSTEIN project in different climate conditions, two full-scale pilot plants were constructed. One of them was located in the Regional Hospital for Nervous and Mental Diseases in Ząbki, Poland, founded in 1903. The main office of Administrative Department is located in a two-storey building with a partially underground basement, which gives 793 m² of usable area.

The building's space heating installation consist of the gas boiler supplying articulated cast iron radiators. Maximum water temperature for supply and return lines is 80/60°C and is designed for outside temperature up to minus 20°C. Those are typical temperature values for old space heating systems designed for climate conditions in central Poland. Domestic hot water is supplied by local electric heaters.

The building was retrofitted ten years ago, the renovation included new windows, new 90kW gas fired boiler and weather-compensation control implementation. However, the average annual heat consumption for space heating purposes is still very high due to lack from building envelope insulation – up to 200 kWh/m² per year.

At the beginning, conventional gas fired boiler had been the only source for space heating. Within the scope of EINSTEIN project the space heating system was later upgraded by adding flat plate solar collectors, above-ground medium scale Seasonal Thermal Energy Storage tank (STES) and the prototype heat pump (Figure 3). STES and solar collectors in the Pilot Plant are shown in the Photo 1.

Those system components were dimensioned by Solites partner in the simulation software TRNSYS. The input parameters for program were i.e. heating demand, existing installation parameters, as well as the weather data. As a result, several scenarios were generated to choose between most energy efficient configuration and components dimension. Based on the results of TRNSYS simulation, the solar collectors should be able to provide about 82 MWh/year and the resulting solar fraction will be of about 30–50% of annual heat demand. Due to Administrative Building's high thermal energy demand per square meter, it is possible to refer results to i.e. one much larger insulated building or a complex of several such a buildings.



Photo 1. View of the Polish Pilot Plant (STES and solar collectors field)

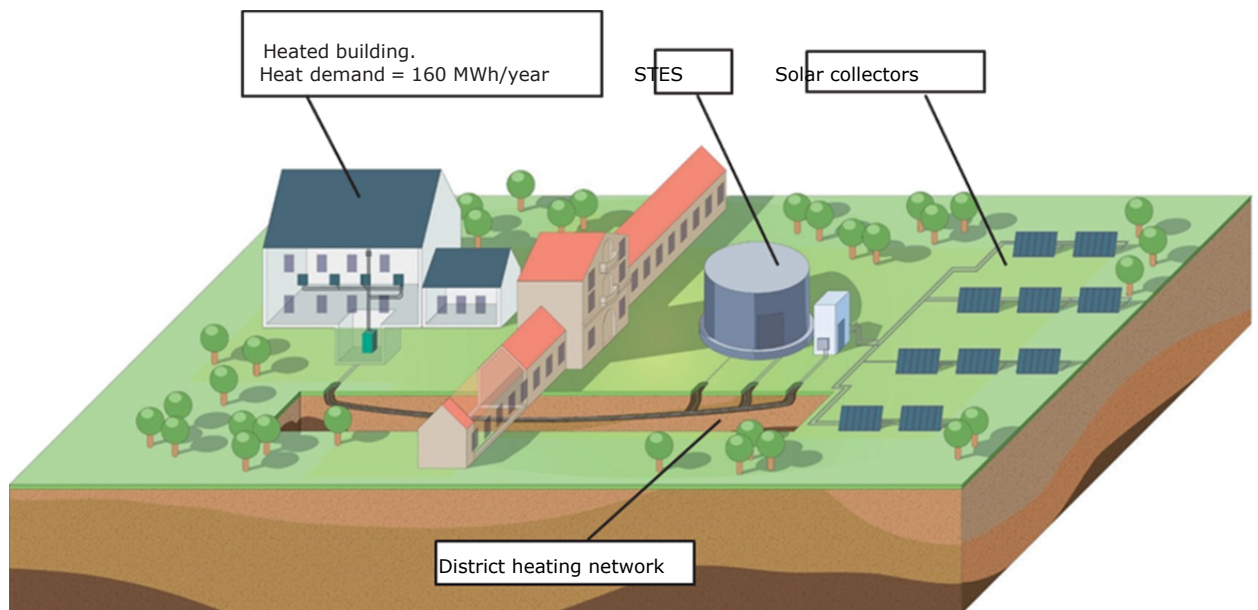

Figure 3. Concept of the heating system

After choosing optimal system configuration in terms of energy efficiency other feasibility studies were conducted to determine the most suitable construction works solutions. This approach allowed to prepare detailed work schedule resulting in a short duration of construction works. The Horizontal Direct Drilling method was chosen to trace pipes connecting EINSTEIN installation with Administrative Building. Thanks to utilization of a

trenchless technology and proper coordination on a construction site, it took only four months to build the complete system.

After the design phase, 151 m² (net) of solar collectors provided by Viessman was installed by MAE partner in the field near the STES. The collectors loop is filled with propylene glycol transferring thermal energy to the heat exchanger's water loop directly into the STES tank. The water supply system is presented in the Figure 5. Cold water is drawn from bottom of the STES and heated water enters the top resulting in thermal stratification inside the STES in order to increase the overall efficiency of the system.

The polish pilot-plant STES is designed as an above-ground tank and constructed in a similar way to firewater tanks. To keep the heat losses as low as possible, the tank is completely insulated by mineral wool from the sides, by styrofoam and PUR sheets from the top and by foam glass gravel from the bottom. The size and location of the hydraulic connectors to the tank were designed to optimize the efficiency of charging and discharging process. As a result, the installation was connected to the tank at the bottom, in the middle and at the top. The EPDM liner was installed inside the STES to ensure its water-and vapour-tightness. The EPDM is a synthetic rubber, impermeable, resistant to high temperatures, durable and elastic. The temperature of water inside the STES will vary from 30°C at the end of heating period to about 80°C at the end of the warm period. All of STES constructions works were executed by Mostostal Warszawa S.A. partner. The underground, distribution heating network between STES and the building was performed by ICOP partner. Based on the characteristic of the terrain and geological data, a decision was taken to carry out HDPE pre-insulated pipes, using trenchless techniques. The horizontal directional drilling HDD technology was selected as the most optimal. The initial and final part of the pipeline was done by opening trench excavation.

Due to the fact that one of the hospital buildings was located along the route of distribution heating network, the careful monitoring of that building structure was carried out during the trenchless works. In the basement of the Administrative Building the innovative, water-water heat pump was installed. The role of the heat pump is to utilize low-grade heat in order to enhance the overall energy-efficiency system. When water temperature is too low for heating purposes, low-grade heat from STES is converted by the heat pump to ensure adequate temperatures and transferred to a space heating system.

In EINSTEIN project, for the first time in a full-scale STES pilot plant with the heat pump as started-up. The newly developed by Ulster University high

efficient heat pump is able to work with wide temperature range of a heat source. It is required as the temperature in the STES circuit will decrease through winter to the end of the heating period. R245fa was selected as the appropriate refrigerant to work safely and stably within the range of the required temperature (between 25°C to 70°C on the evaporator site). The maximum thermal power of the heat pump is 120 kW, thus the unit is able to cover the heat demand of the entire building. To protect the heat pump evaporator against the poor water in the STES, both circuits are hydraulically separated by the heat exchanger.

The final layout of the Polish pilot plant is shown in the Figure 4.

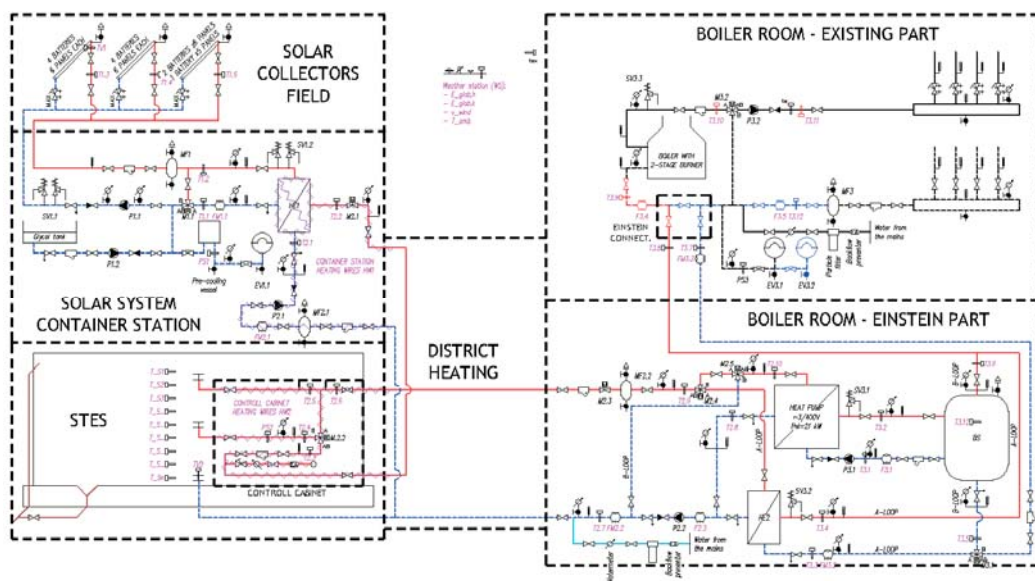

Figure 4. Final design of the EINSTEIN Polish Pilot Plant

The implemented operation strategy involves five main modes. Mode 1 is applied at the beginning of the heating period. The STES is fully charged and covers all of the space heating demand of the building. As the winter progresses, the temperature of the stored water is lowered to the level which is not enough to ensure thermal comfort in the building. In this case, the STES supplies only a part of the building's demand. The rest of the heat is supplied by the gas fired boiler or by the heat pump (modes 2 and 3). When STES is fully discharged the space heating demand of the building is covered by the gas boiler in total (mode 4). The system runs in mode 5 during the warm months. At this period, there is no space heating demand in the building, the STES is charged by the energy absorbed using the solar collectors. A 1 m³ volume storage buffer is designed to ensure acceptable operation times for the heat pump. The buffer storage is also used to uncouple the energy production of the EINSTEIN part from the energy

system from the existing part (gas fired boiler). Dimensions of storage buffer were limited by space availability in the boiler room.

The design process of developing control algorithms was a very complex task integrating six subsystems: solar thermal, storage, heat pump, distribution network, gas fired boiler and inside distribution system. Smooth switching between subsystems is crucial for EINSTEIN system to work in the most energy-efficient manner. The weather conditions, STES level of charge, space heating demand of the building, the key plant temperature, flows and pressures are monitored and taken into account to optimise the system operation. Control algorithm and the monitoring system was developed by CIM-MES partner.

The STES construction and integration of the boiler room (Figure 5) with the existing space heating system was executed by Mostostal Warszawa SA. The Polish pilot plant started in July 2014 and heat pump was installed and started-up in October 2014. The boiler and its equipment is presented in the Photo 2:



Photo 2. Boiler and its equipment installed room after modernization

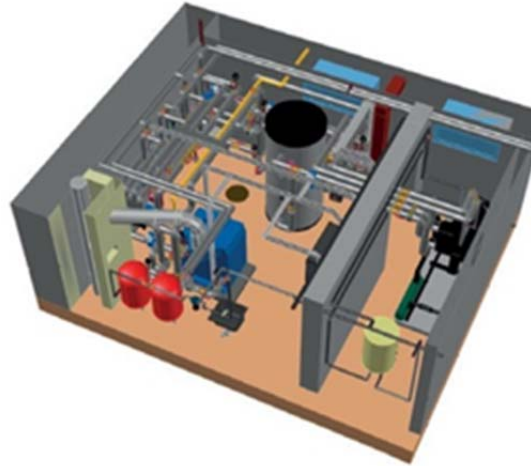

Figure 5. The 3d layout of the boiler in the Polish Pilot Plant

The first year of operation allowed for the testing of heat pump prototype, checking system's reliability and selecting the most appropriate operational strategy. The second year of operation has provided figures on the overall system performance in terms of energy and economic efficiencies.

3.2.- THE PILOT PLANT IN BILBAO, SPAIN.

The Spanish pilot plant was installed in Bilbao near the center of the town, and it is dedicated to cultural events. The construction works were executed by Tecnia and Acciona Infrastructures SA partners. The Seasonal Thermal Energy Storage tank and the entire installation are used only at the building level. The objective of the Spanish pilot plant is to cover approximately 30% of the heat demand of the retrofitted building.

The building has been equipped with a low temperature underfloor heating system. An air handling unit is in charge of supplying ventilation air. The site has a total useful surface of 1,050 m² with a capacity for a maximum of 500 people divided in two areas: 800 m² for cultural events and 250 m² for a cafeteria.



Photo 3. View of the 800 m² surface for cultural events



Photo 4. View of the 250 m² surface for cafeteria and art events

Before the EINSTEIN project demo installation, the facility used a conventional 190 kW natural gas boiler for heating purposes and now both systems are integrated in one unified heating system. The total heat demand has been estimated to be around 83 MWh/y. Bilbao is located in the north of Spain. The climate in Bilbao is characterised by two seasons with low intensity thermal variations. Its average annual temperature is 14°C (night) and 19°C, during the day. There is two times more sunlight in the winter than in the north of Europe. The total yearly irradiation is 1272 kWh/m², and the total number of solar collectors operation hours is about 4150.

The new installation can supply heat for space heating by means of:

- Solar collectors (62 m²), directly if the heat demand and enough solar radiation exists, the very high efficiency of solar collectors was achieved by its installation at a tilt of 45°, and with orientation due south
- STES tank (160 m³),
- Conventional heat pump (69kW thermal, provided by the partner Airlan). If the temperature of the water stored in the STES tank is between 25°C and 10°C, the heat pump uses the heat stored in the STES tank for space heating.
- When water temperature of the STES tank goes down to 10°C (risk of freezing in the HP), the natural gas boiler is used.



Photo 5. View of the STES in the Spanish Pilot Plant

The STES was erected inside the existing building attached to the demo building. It significantly influenced the tank design, and the low mechanical strength of the soil did not allow building a tank with a higher H/D ratio of 1. The roof of the building had to be removed and a reinforced concrete slab was built for the load distribution over the pre-existing slab.

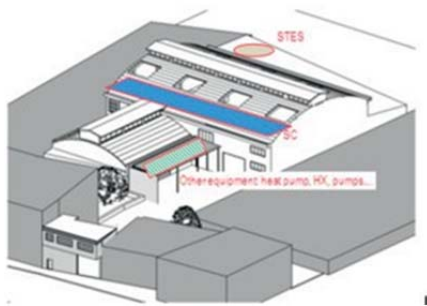

Figure 6. Main equipment of the Bilbao Einstein demo

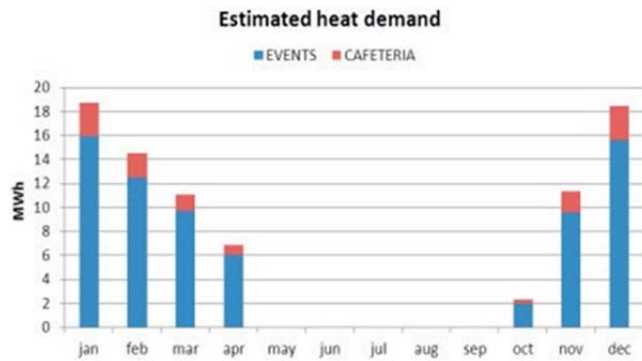

Figure 7. Estimated heat demand at Bilbao demo

The STES was designed as a double metallic tank, one inside the other and concentric, and leaving a chamber to be filled with thermal insulation between them. Tanks are formed of corrugated galvanized sheet bolted steel using an epoxy board in each junction (see photos n. 6-8). With these characteristics, the design meets some innovative characteristics: a double independent tank, with less thermal bridges due to absence of supports, and the possibility to be filled in with a blowable type insulating material based on recycled Polypropylene; modular construction; insulation over the ground, and regular distribution of charges over the ground (not increased in perimeter). The tank is an open type tank and operates at atmospheric pressure. A venting system located in the upper expansion chamber is designed to avoid a continuous waste of water vapor thanks to a siphon closure. It also acts as an overflow prevention system.



Photos 6 and 7. Detail of the corrugated galvanized sheet bolted steel and the double tank system

The inner tank acts as the true watertight container, while the external acts as a container of the insulation (granular). The external tank has the function of containing the insulation of the tank, by filling the cylindrical ring between the two tanks with a granular insulation material (recycled polyurethane). Also in the covering, the insulation is made by filling the space between the two covers. For the bottom part, the insulation is made by using a rigid insulation over the insulation slab, and under the waterproofing liner.



Photos 8 and 9. Detail of the insulation of the space between both metallic tanks and the bottom part.

The initial criterion that has been taken to calculate insulation requirements is to establish maximum losses of 10°C (from 85 to 75°C) in a tank during 60 days (considering a static situation of the tank, without adding or

extracting heat from the tank). Based on TRNSYS simulations, final thickness of 0.55 m of insulation was selected. Above that value, the cost of additional insulation is not outweighed by the savings it provides. With the double tank design, the space between both has been filled with a granulated PUR as insulating material. There are no connections between both tanks (they are self-supporting, only the hydraulic piping links them), so that a continuous insulation cover- age with no thermal bridges is developed. The material selected for bottom insulation was expanded clay due to its easy availability for use, and good balances between thermal insulation and compression strength. The mortar surface that finishes the insulation expanded clay (under the EPDM layer), is painted with an epoxy coating, that acts as a vapor barrier. A venting system is located in the lower part of the slope, to drain the possible water condensation that could be formed above this coating. The thickness of 0.40 m (minimum) was used for the bottom tank insulation. Due to the thermal stratification inside the tank, the bottom area is the coldest, so thermal losses are lower in this area.

The inner tank is painted to protect against corrosion. The painting not only covers the metallic parts, but also covers the outline of the elastic joints between the metal parts, so full protection is achieved. At the bottom, the water closure is achieved by a waterproof layer attached to the base. An EPDM layer is used as the waterproof layer. Connections can serve as inlet or outlet depending on the operating mode. When charging the tank, the bottom connection acts as an inlet, cold water is extracted from the bottom of the tank that returns hottest through the upper connections. While discharging (using the stored heat), the flows are the opposite, hot water is taken from the tank through the upper connections, and comes back to it through the lower connection. To enhance the heat storage, the uptake, and mainly, the discharge of flow into the tank has been carried out through three "stratification devices", elements that increase the area where the flow enters into the tank, so its velocity is low enough to avoid turbulence. A vertical thermal stratification method is used to separate warm and cold water inside the STES (see photo 10).



Photo 10. Stratification devices.

The following pictures show the 62 m² solar collectors installed on the roof of the building and the WRL 200 R410A heat pump that can operate between 28°C and 10°C. As said, it has a total thermal power capacity of 69 kW and a COP of 4.16 at nominal conditions.



Photo 11. Solar collectors (62 m², 27 collectors)

The hydraulic system consists of a primary circuit of isolated copper tubes which uses ethylenglycol as thermal fluid and the secondary circuit, with isolated polypropylene piping. The installation is formed by solar collectors, the STES tank, the buffer, the heat pump, the natural gas boiler

and the space heating system (underfloor heating and air handling unit). The lay-out of the installation is shown in the picture below:

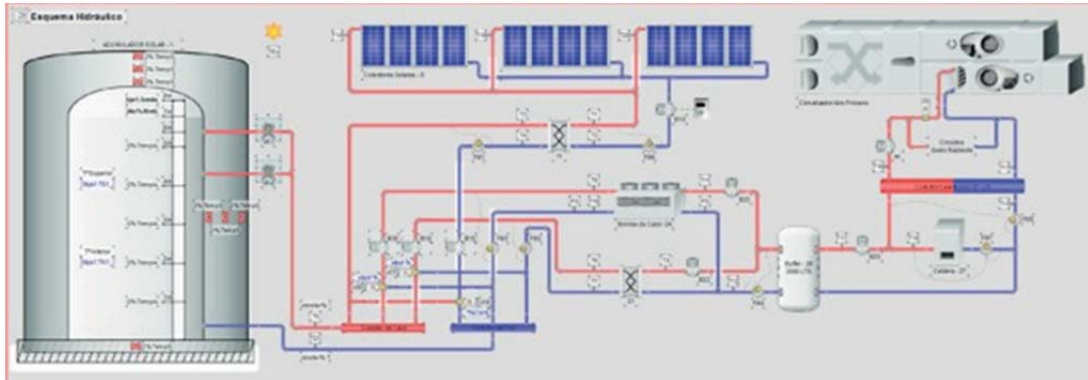

Figure 8. Layout of the Bilbao demo

A control and monitoring system has been installed to measure, display in a screen and record all data related to the system: five thermocouples inside the STES tank, each one meter in height, seven thermocouples that measure the temperature of the insulating material of the STES tank and also in several points of the primary and secondary circuits. Apart from this, a pressure probe has been installed to measure the water level in the tank, several heat meters are located in the primary and secondary circuits that allow the flow, temperature and heat to be measured. A solar radiation probe has also been installed. Data analysis results will be benchmarked against other plant- operating options to draw comparisons, contrasts and conclusions.



Photo 12. Heat pump

An Exo-Scada design programme has been used to allow data collection, management of failure and alarms, switch on/off the equipment, etc. The system is linked to a web server to connect to the Scada base to check the installation and to operate it by remote control.

The installation of the equipment of the Spanish demonstration plant started in April 2014 and finished at the end of July. Since 29 July 2014, the installation has been running in charging mode, namely storing water heated by means of the solar collectors in the STES tank, mainly in summer. In winter, several heat discharges to heat the building from the STES tank have been performed.

Concerning heat losses from STES tanks, tanks of Polish and Spanish demos show better performance of STES in comparison with other previous STES tanks:

		Hamburg	Friedrichshafen	Hanover	Bilbao	Zabki
storage volume	m ³	4,500	12,000	2,750	180	800
mean temperature difference to ambience	K	42	49	33	49.2	43.3
heat flux to ambience (heat losses)	kW	45.1	38.8	10.8	1.9	5.9
heat loss rate (UA)	W/K	1,073	792	329	39	135
storage surface	m ²	1,650	2,796	1,135	192	526
specific heat flux to ambience (specific heat losses)	W/m ²	27.3	13.9	9.6	10.1	11.1
overall heat transfer coefficient of STES	W/(m ² K)	0.650	0.283	0.290	0.203	0.257

Table 1. Comparison of technical features of STES tanks from different installations.

Although Zabki and Bilbao STES tanks are much smaller than the rest of the tanks and the higher the volume the lower the specific heat losses, these two tanks present better performance than the other tanks in terms of overall heat transfer coefficient.

3.3.- USE OF HEAT PUMPS IN COMBINATION WITH STES IN LOW TEMPERATURES. THE POLISH PILOT PLANT CASE.

The main challenge for Ulster University partner (responsible for the heat pump development) was to develop a heat pump suitable for STES systems and retrofitting applications. This means that higher temperatures than conventional values are needed in both evaporator (to use the heat stored in the STES) and condenser side (to meet building requirements at temperatures up to 75°C). While maintaining the belief that off-the-shelf equipment was appropriate for this task, a number of working fluids were examined, the properties of which were such that pressures at

temperatures of 75°C and below were in line with traditional pressure ranges. R245fa emerged as a likely candidate with temperatures of 14.8°C and 62.7°C for 1 barA and 5 barA respectively.

The challenges are then compressor lubrication (oil viscosity, miscibility etc.) and electric motor temperature when operating at elevated evaporator temperatures. Heat transfer proved to be marginally challenging as major brazed/welded compact plate manufacturers incorporated R245fa properties into their design portfolios. However, expansion valve manufacturers required new algorithms to address superheated properties of R245fa. These solutions, where appropriate, were incorporated into a small scale water to water heat pump facility at Ulster University utilising a scroll compressor, compact plate heat exchangers and an electronic expansion valve to test the theory of R134a equipment suitability

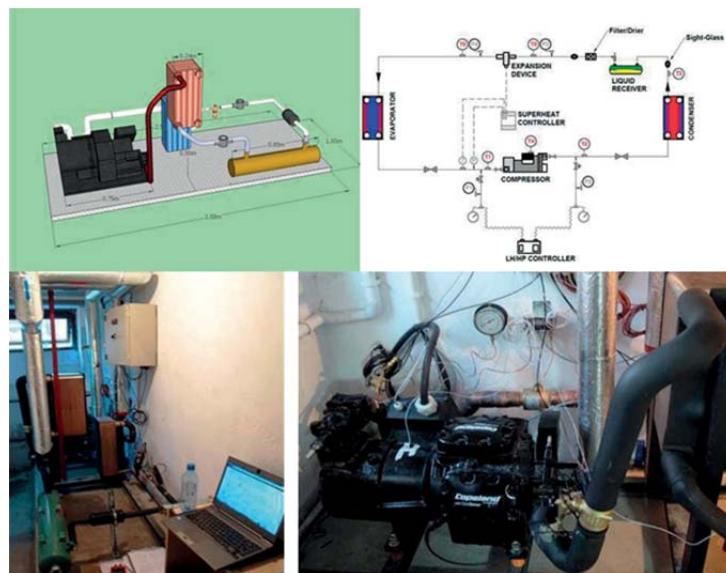

Figure 9. Schematic Sensor Positions and Images of the Heat Pump on site

3.4.- DESIGN AND IMPLEMENTATION OF THE EINSTEIN CONTROL SYSTEM

Connecting the electric and thermal energy generators together with energy accumulation units (e.g. STES) with a district heating grids is very promising, but requires an advanced approach to the control system, as its complexity is strongly increased. Within the EINSTEIN project, CIM-mes partner has developed smart controllers for highly efficient multisource heat generation including district grids and a connection to electrical grid using

novel high temperature heat pumps.

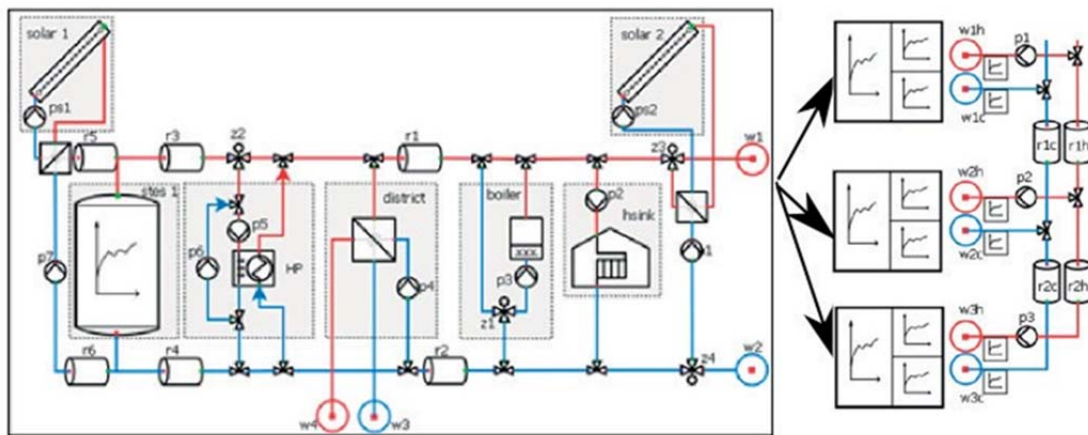

Figure 10 . Simulation of solar collectors and thermal energy storage coupled with district heating.

The control over the considered system is a complex task, due to fluctuating renewable energy sources and contradictory requirements of different system elements, e.g., the solar collectors are more efficient at low temperature and often district heating and existing buildings require high working temperatures. All components must work together regarding variable external conditions (e.g. weather, prices of energy) and several internal and external constraints. It has to combine day-to-day and seasonally varying operation. Working parameters, in particular temperature, flow rate and dynamical constraints must stay within the region of stable and effective operation as the overall performance depends on the efficiency of all system elements. The simulation results and the pilot installations developed within the project show that it is possible to find a trade-off between these requirements, however, advanced numerical tools must be used during the design process, and especially during its operation. Efficient control algorithms optimising the system's performance are crucial.

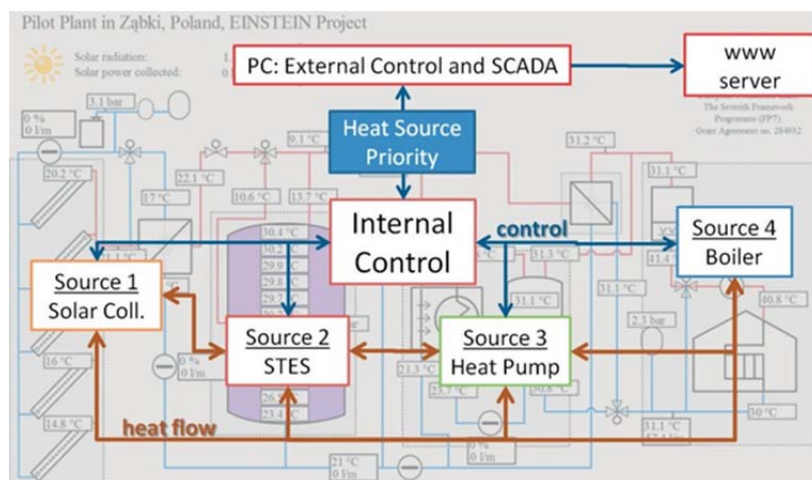

Figure 11. Control approach at the Polish pilot plant. The multi-source heating system with

solar collectors and seasonal energy storage is controlled using a two level approach.

The control algorithm developed for the Polish pilot plant contains a two-level approach. The low level controller is responsible for the implementation of predefined operating modes for heat transfer between different heat sources, heat storages and heat consumers. The high level control is responsible for optimising the overall system performance by taking the historical data, current system state and future predictions into account.

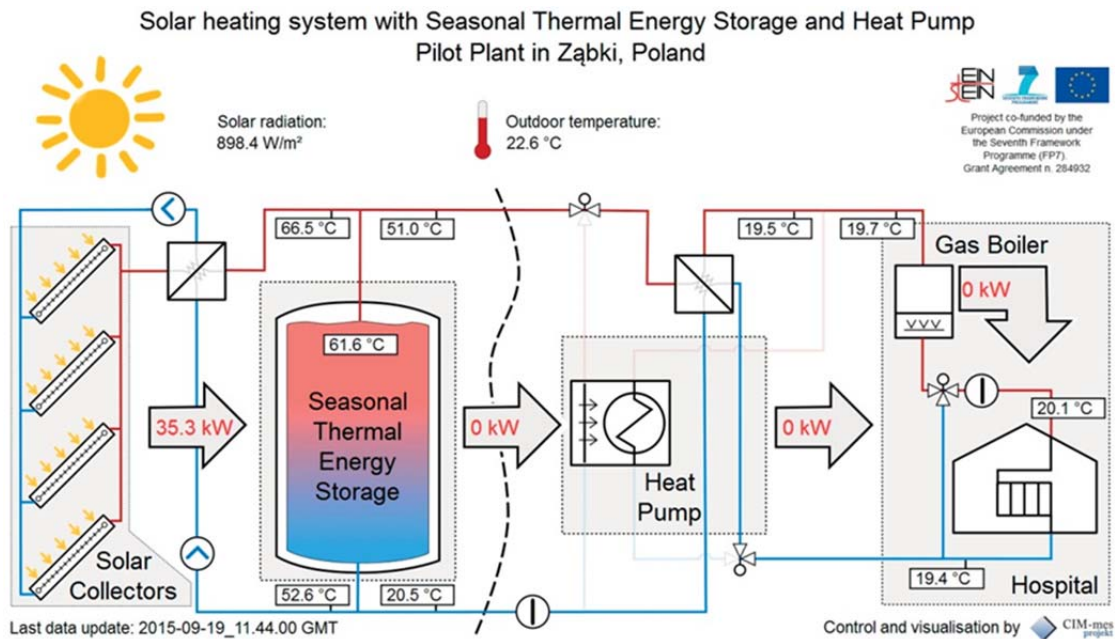

Figure 12. District manager interface

3.5.- DEVELOPED TOOLS AND DESIGN GUIDELINES.

Two tools have been developed in the project:

- An Evaluation tool to assess the cost-effectiveness of the different retrofitting strategies, including passive and active measures
- A Decision Support Tool for selection, preliminary design and evaluation of STES systems in existing buildings

Besides, the following two public reports as guidelines have been developed:

- "Guideline for the Seasonal Thermal Energy Storage in the built environment", focused on storage systems (tank, pit and borehole STES)
- "Design guidelines for STES systems for all Europe", addressing the key issues to be considered when designing a solar assisted heating system with seasonal thermal energy storage technology

Both reports are public and are available in the project website: www.einstein-project.eu

3.5.1.- Evaluation tool to assess the cost effectiveness of the different retrofitting strategies

A methodology to assess the most cost-effective global energy retrofitting intervention for the existing buildings, considering active and passive measures as well as the integration of STES as an alternative has been developed in the Einstein project.

The Evaluation Tool analysis different combination possibilities from energetic and economic point of view and identifies the most cost-effective combination for the boundary conditions specified by the user and to achieve a certain primary energy reduction, introduced as well as input by the user.

The following passive retrofitting measures are considered by the tool: to add insulation in the façade, to add insulation to the roof, to add insulation in the floor and windows renovation. In every case, two renovation levels (medium and deep) have been defined. The potential for energy demand reduction and the investment cost of each of the intervention considered has been estimated for four specific locations (Amsterdam, Madrid, Warsaw and Stockholm), defined within the project as representative locations of four different climatic zones with different building sector characteristics.

Regarding the active systems, state-of-the-art technologies (figure 13) and STES system have been considered as alternatives. The investment cost and primary energy reduction potential of the different active systems when covering different energy demands have been quantified.

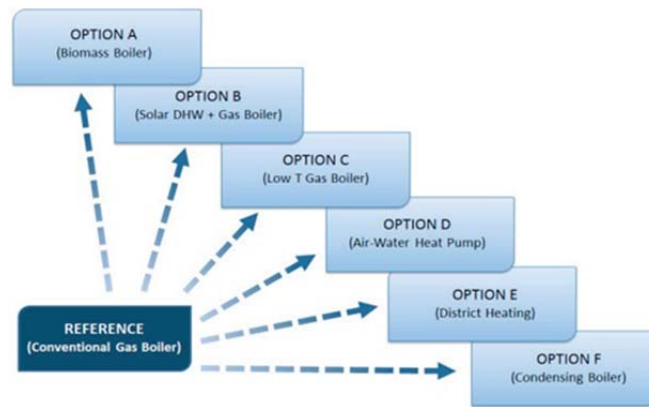

Figure 13. Active conventional retrofitting options considered in Decision Support Tool

The large amount of data generated with the simulations has been structured in a database that feed data to the Evaluation Tool. The user should introduce input data to define his own study case (climatic region, type of building, total surface to be analysed in that type of building plus the desired % of primary energy reduction) and the Evaluation Tool consults the database to assess all the possible combinations and identifies the best combination among all the passive and active retrofitting measures considered for every range of primary energy savings (0–20%, 20–40%, 40–60%, 60–80%, >80 %).

3.5.2.- Decision Support Tool for preliminary design and evaluation of STES systems

The Decision Support Tool (DST) has been developed for the evaluation of a potential implementation of STES systems in existing buildings. DST considers the most relevant technical issues in a STES system design and gives an evaluation of the system from energetic, environmental and economical point of view. The DST is designed to be a powerful and user friendly calculation tool that allows Engineering and Construction companies without a specific expertise in these systems to perform a preliminary system design. The provided results may help to identify the most suitable STES technology for the particular boundary conditions of the case under examination.

The DST is a user-friendly tool enabling users to get preliminary information on the design of a STES system. The purpose of the developed tool is not to avoid the realization of detailed simulations that are anyway required to design the system, but to give preliminary data that can be useful for users with limited expertise on

these systems. This tool may allow stakeholders to consider the STES systems as an option in their feasibility studies or new projects, helping to foster STES systems implementation across Europe. The importance and impact of the developed tool is remarkable, especially taking into account that there are almost no available tools for this purpose. So far, there was only one available tool that does not require a high level of expertise (developed within the EU funded project SDHtake off). The developed DST complements this tool extending the scenarios and boundary conditions that can be considered.

An additional added value of this tool is represented by the possibility of analyzing centralized as well as distributed configurations for the energy generation and distribution at building and district level. In both cases, solar plant and storage volume are centralized, but heat pumps and auxiliary boilers could be either centralized or distributed in buildings.

The Decision Support Tool described before has been developed as a Web-based application and it is currently available on-line for free at the following link:

<http://einstein.dappolonia-innovation.com/einstein-dst/login.jsf>

3.5.3.- Guideline for the Seasonal Thermal Energy Storage in the built environment

The content for the design guideline is somewhat a summary of all the work performed during the project regarding specifically the seasonal storage component. The performed work and obtained results have been collected and reported in a public report with a user-friendly graphical design and guidance that enables easy access for the interested reader to what he is looking for.

The report focuses mainly on three STES types that are collected in the following table.

Table 2: STES systems overview

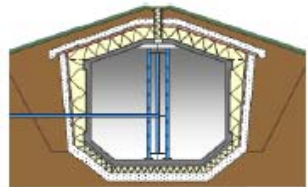
Tank Thermal Energy Storage (TTES)	
<p>Concrete, stainless steel or fiber reinforced polymer tanks built on or partially or totally under the ground and filled by water. Depth: from 5 to 15m Suitable geological conditions: tank construction can be built in well stagnant ground, soil class II-III, as much as possible avoiding groundwater. Usually highest specific cost compared to PTES and BTES, but lowest required volume (highest efficiency)</p>	

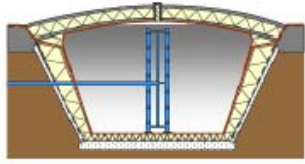
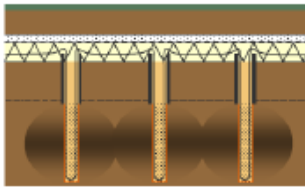
Pit Thermal Energy Storage (PTES)	
<p>Artificial pool closed by a lid and filled with water or gravel-water mixture. Depth: from 5 to 15m Suitable geological conditions: pit construction can be built in well stagnant ground, soil class II-III, as much as possible avoiding groundwater. Usually lower specific cost but higher required volume than TTES (lower efficiency)</p>	
Borehole Thermal Energy Storage (BTES)	
<p>Vertical boreholes in which are inserted u-pipes, also called ducts. Water run in the u-pipes. Depth: from 30 to 100m Suitable geological formations: rock or water saturated soils with no or only very low natural groundwater flow. The ground should have high thermal capacity and impermeability. Usually lowest specific cost compared to TTES and PTES, but highest required volume (lowest efficiency)</p>	

The guideline offers necessary explanations and information to STES component. Within newly developed matrix an easy guide to application possibilities in existing building structures and its specific prerequisites etc. is given.

3.5.4.- Design guidelines for STES systems for all Europe

STES systems are not a mature technology yet. There are several pilot plants in Germany, several large plants in operation in Denmark and a few installations more all over the world, but in general the number of plants in operation is low and STES systems are not a known technology yet. The information that is available in the literature is as well very scarce. This report aims to contribute to this situation with providing guidelines and recommendations regarding the planning and preliminary design of STES systems.

The aim of the document is to provide useful information and general guidelines that may be useful for a preliminary assessment of a new STES system. When planning a STES system, a diversity of influencing boundary conditions should be properly considered, which should be assessed in a holistic approach. The report focuses on STES systems with solar thermal energy and heat pumps. The document includes the influence of parameters as:

- Heat demand, heat distribution systems, operational temperature, load profile,
- Climatic conditions (solar irradiation, outside temperature),
- Space requirements and recommendations for solar collectors and

volume of STES tank (three different types have been considered: TTES, PTES and BTES).

- Heat pump integration, etc.

The main influencing boundary conditions when planning the integration of a STES system are explained within the report. The key issues related to the building stock characteristics and the district in which the STES will be integrated are listed and described, together with the assessment of climatic boundary conditions that highly influence the design of a STES system. More specifically, the key issues related to the integration of main subsystems of a STES system (solar collectors, storage, heat pump and other auxiliary equipment) are as well described.

Recommendations for subsystems integration have also been included. A large amount of variables and of high diversity are involved when planning a STES system. The most important variables, recommendations and indicative values for an appropriate subsystems integration that can be useful for a preliminary system completion have been included. This information will help designers or any interested body that is not expert on STES systems in the sizing process of a STES system. The key issues on STES systems sizing have been identified and explained, and they have been complemented with guidelines and indicative values that can help making an idea on the expected size of the STES system.

3.6.- TECHNICAL, ECONOMIC AND FINANCIAL FEASIBILITY ASSESSMENT OF STES SYSTEMS FOR BUILDING RETROFITTING

The technical, economic and financial feasibility of 'Einstein STES' installations under different boundary conditions has been analyzed.

The key point of this technology is that being a passive element of a thermal system it makes possible to use the surplus energy that otherwise would be lost. This means that fossil fuels consumption is being replaced by the surplus energy coming from waste and/or RES. STES has the potential to significantly increase the use of solar thermal energy and waste heat, which are two sources that perfectly fits with the STES concept, both often characterized by having a considerable amount of surplus heat in summer months.

An important feature of STES systems in terms of energy saving potential is that we are talking about a technology able to reduce primary energy consumption at very high ranges (>50%, theoretically up to ~100%), which cannot be said about any technology. In the following figure simulation

results of a specific case study considered within the project are shown. It clearly reveals that the STES technology is able to drastically reduce the PE consumption.

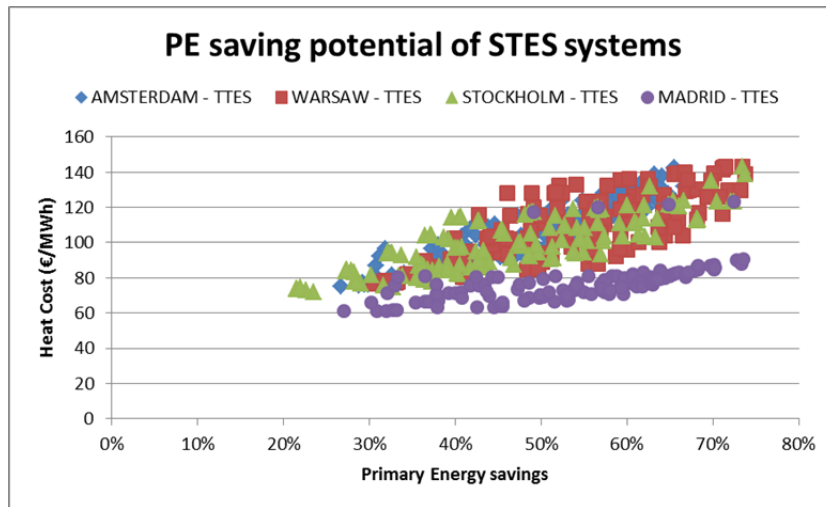

Figure 14: PE saving potential of STES systems

The suitability and potential of STES systems from technical point of view is clear but it is well known that economic feasibility is and will be a requirement so that the STES systems can be implemented in the real market and succeed in the future. In this regard, the main conclusions from the Einstein project are shortly summarized in the two main issues explained in the following lines.

System size is a key issue. As bigger is the system, lower are the specific costs. This seems to be an obvious and generic statement that is applicable to any situation, but it is much more relevant for STES systems as there are additional reasons (thermodynamic and geometric) besides the common economy of scale.

The figure 15 below shows the specific investment cost of the different storage systems built in the last years (the cost refers only to the storage, not to the whole plant). It is clear that the specific costs are significantly reduced for larger volumes. The Einstein project has given two demonstration plants (one in Bilbao (Spain) and a second one in Warsaw (Poland)). The implemented R+D activities have shown that is possible to build them with lower specific costs than the older pilot plants of similar sizes.

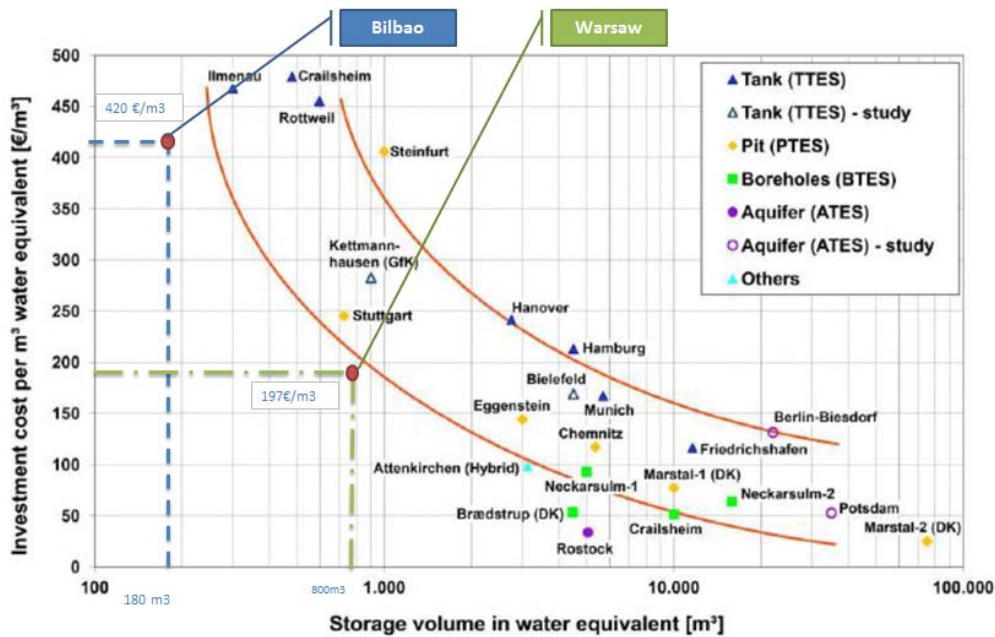

Figure 15: Specific investment cost of different STES typologies of real plants

The figure below shows the evolution of the heat cost of a STES plant for different district sizes. "Heat cost" is understood here as the total costs of producing each kWh delivered to the buildings and to cover the whole demand, considering both solar heat and the remaining energy coming from auxiliary equipment. It is therefore a value that can be used directly when comparing for instance against individual gas boilers. Taking into account that the cost of natural gas for domestic use in Stockholm is 63,9€/MWh (average 2014, source: Eurostat), it can be concluded that this specific case study for instance can be competitive in the market without subsidies under certain circumstances: making it big enough.

The heat cost of a STES system depends on a large amount of variables such as energy price, location, ground characteristics, solar fraction, etc. which makes to substantively vary the heat cost from one project to another. But what can be stated is that the heat cost is significantly reduced as larger is the plant. In the considered specific case for instance, the heat cost is reduced to a half approximately (from 115€/MWh to 61 €/MWh) if the plant is built for a large area with a heat load of around 10.000MWh instead of a smaller area of around 1.000MWh of heat demand.

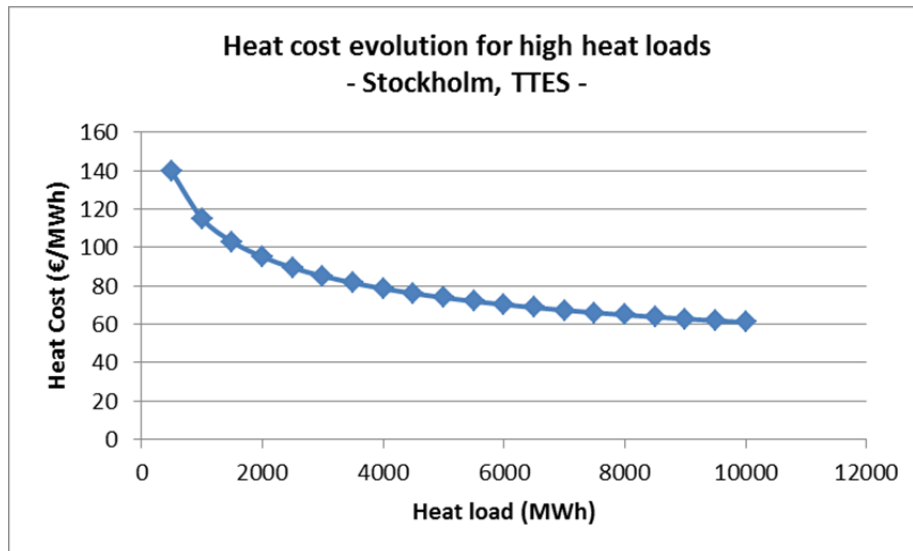

Figure 16: Heat cost of STES plants depending on the heat load to be delivered

To give an idea of the sizes we are talking about, the following numbers may be pointed out as guidance: this specific case study may require around 3.200m² of solar collector field and ~8.300 m³ of STES for the small district (1000MWh) and ~30.000m² of solar field and ~78.000m³ of storage for the large one (10.000MWh). This gives an idea about the kind of projects we are talking about. It would be really difficult, if not impossible, to carry out such ambitious projects without the involvement of the corresponding public authorities. In this regard, the message is therefore double:

- STES system is a technology to be implemented at large scale (leaving aside the required pilot plants to advance on scientific knowledge and technological progress)
- One of the main stakeholders in terms of final users for this technology are public authorities, meaning that the message/technology should arrive to them and on the other hand, that they are who can introduce (push, promote) these systems in the market. It is clearly a "Smart City Technology".

The second key point concerning economic feasibility of STES systems is the importance of an appropriate design of the installation. This is apparently a quite obvious statement that may be applicable for any thermal system, but it is extremely relevant for STES systems. A thermal system based on seasonal storage concept is formed by many subsystems (heat sources (solar collectors, waste heat, other sources...), heat pump (optional), the storage, distribution network...) and its design is a multi-dimensional problem with a large amount of variables that are highly interrelated. The nature of the technology allows operating the plant even the components are highly oversized, for instance the storage, but this highly influences the economic figures of the plant. The lack of knowledge due to a limited number of existing STES plants and the complexity of the multi-dimensional

problem of a system that seems to be “easy to be designed”, increase the probability for an incorrect design.

The figure 17 below clearly shows the above introduced topic. It represents the different combinations of solar collector field, storage volume and heat pump capacity for a specific case study considered within the project. There are different combination options that make possible to achieve a certain solar fraction. All of them may be technically feasible, but not to optimize the system size and correctly consider integration aspects may give as a result a system that is much more costly than necessary. According to the results that have been plotted in figure 4, for a solar fraction of around 70% several combinations are “possible” with a heat cost that may vary from ~80€/MWh up to ~140€/MWh; in other words, the heat cost could be up to 75% higher just because an incorrect system sizing. To increase the available knowledge about STES systems will be therefore a key issue also for the economic feasibility and user’s reliability towards this technology

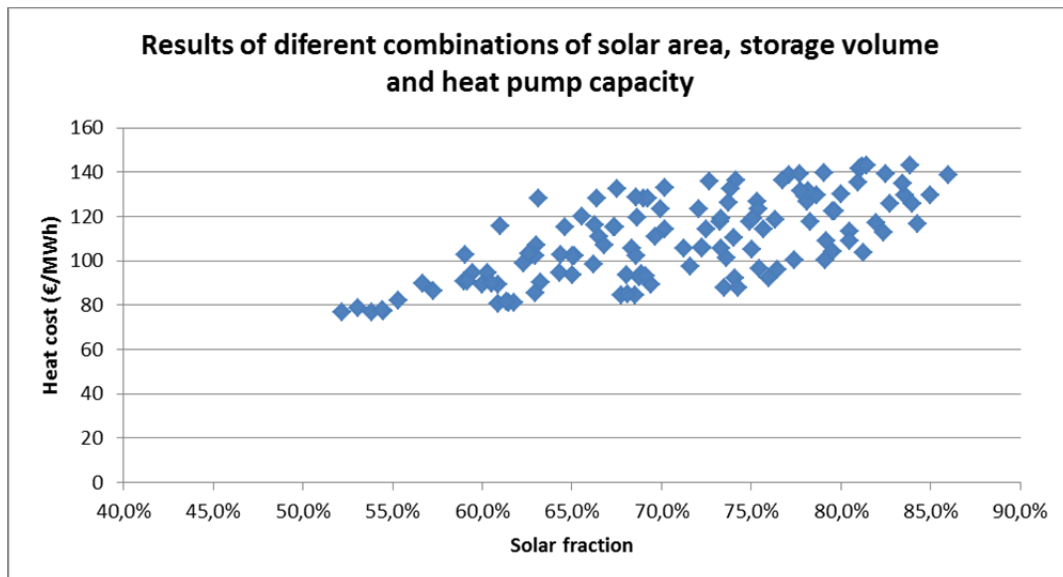

Figure 17: heat cost VS solar fraction of different combinations of solar area, STES volume and HP capacity

3.7.- TRAINING

As an integral element of the dissemination activities associated with the EINSTEIN project, a training programme has been developed and tested during the research project. Training material is available at the project website: www.einstein-project.eu

The training programme is based on the results of the various work packages of the project and draws heavily from the experiences of the partners. It consists of three e-learning programmes addressing the specific needs of:

1. Technical experts (architects, engineers, construction industry)
2. Decision-makers (investors and developers, local and regional authorities, EC)
3. Educators (academic staff, higher education personnel, public administration in charge of energy)

All three programmes were developed in English and then translated into the other seven languages of the consortium, leading to material available in English, German, Spanish, Italian, Polish, Swedish, Dutch and Bulgarian.

All three programmes have been developed in order to be as accessible as possible and do not require any specific e-learning software or the purchase of e-learning licenses. Further, the training programme has been developed to make full use of the available EINSTEIN public material through the integration of the material in the three training modules.

The training programme is one element of the EINSTEIN interaction with the public and specific interest groups, another element of which is the website through which further information and interaction with members of the consortium is possible.

It is planned that the training material will be used by the members of the consortium in support of their STES related activities. This includes planned presentations to energy agencies, third level students, industry bodies and local authorities.

4.- POTENTIAL IMPACT. MAIN DISSEMINATION ACTIVITIES. EXPLOITATION OF RESULTS.

4.1.- POTENTIAL IMPACT

STES systems are an innovative concept but at the same time it can be said that they are not a too complex technology when talking about bringing them to the market. It cannot be said that STES systems are “state-of-the-art” but the required knowledge and experience for the implementation of these installations may be available at many ESCOs. This does not mean that it is already available, but this particular feature strongly increases the potential for its introduction in the market.

Although the current energy framework (in general low prices of fossil fuels) makes difficult the economic feasibility of STES systems unless specific boundary conditions are given, this will change in the future and undoubtedly STES will be a very promising technology for that framework, due mainly to its potential for achieving high energy savings as very few technologies can.

Although from technical point of view the concept behind STES systems is easily understandable and quickly captures the stakeholder’s attention, there are several drawbacks that should be overtaken for the success of STES systems, besides a more sustainable energy framework. The Einstein project has worked in this direction making possible to give a step forward on STES systems.

The main drawbacks can be summarized in the following points:

- Need of technological progress: STES systems are not a mature technology and although there are a few systems in operation at present research needs in order to advance on the specific fields related to the technology are evident. Indeed, these advances should, directly or indirectly, bring a cost reduction.
- Limited knowledge: so far there are only a few pilot plants built, mainly in Germany, and a few large scale plants in Denmark. The available information and knowledge about the design, construction and operation of STES systems is very limited, and this may dramatically reduce the extension potential of the technology: it may not be considered as an alternative due to limited knowledge or simply unawareness, incorrect designs may bring relevant overcosts, undesirable experiences due to insufficient skills may bring lack of interest on the technology...etc.

The impact of the Einstein project can be reported therefore under these two points identified above.

In the following points the technological impact that the project development has brought to STES systems is pointed out:

- New insulation materials for STES: comprehensive laboratory tests have been performed and practical guidance for realization of long term durable heat insulation systems in STES is given. The regarded low permeability concrete materials show promising results for a further development of such kind of materials, promising a high potential of cost reduction of TES with concrete structure (reduction of about 20% of buildings costs).
- An innovative heat pump able to work with particular boundary conditions that are present in STES system and suitable for unfavorable working conditions of existing buildings has been developed. A heat pump has a direct impact on the whole STES systems, as among other issues, it increases the storage density of the STES and can significantly increase the solar fraction that can be achieved. At present commercial heat pumps suitable for large scale STES systems are very limited. The availability of a heat pump that can be integrated into a STES system will make possible to have in the future STES systems with higher performances. Furthermore, the fact that the heat pump is able to produce heat at higher temperatures than conventional heat pumps makes of this equipment an interesting alternative for retrofitting applications, increasing this way the existing portfolio of cost-effective and efficient heating solutions for retrofitting applications with the corresponding impact in the building retrofitting sector.
- The implementation of the results and conclusions derived from the R+D activities carried out during the project have shown that is possible to build STES with lower specific costs than the older pilot plants of similar sizes, while keeping the technical performance. This shows the relevance of the generated knowledge, which should be further exploited and applied in future STES systems.

Regarding the fact that there is limited knowledge about STES systems the Einstein project has made a significant effort to impact on this issue and give a step forward:

- The report "Guideline for the Seasonal Thermal Energy Storage in the built environment" is the first actual written English report that offers the necessary explanations and information to STES component. Within newly developed matrix an easy guide to application possibilities in existing building structures and its specific prerequisites, etc, is given. It describes how a STES has to be designed regarding its components with a summary of basic rules and the emphasis on conditions that are fundamental for retrofitting applications.

- The report "Modular construction description systems for STES technologies" is the first available English report that describes the materials, methods and procedures to realize a STES. With this report the building industries receive the ability to understand the construction of TTES, PTES and BTES, to derive the design of a single STES and to perform the realization and building process of a single STES.

- The report "Design guidelines of STES systems for all Europe" is the first actual written English report that describes the relevant issues to be considered and challenges to be solved when planning the integration of a STES system. Especially the five conceptual schemes are important for further STES system development all over Europe giving a systematic basis on how to proceed with STES system integration. Further this report gives a comprehensive technical guidance on boundary conditions and possible interactions that has to be regarded and benefits that might be produced when integrating a STES into a heating system. With this report the stakeholders are able to make a preliminary assessment on the design requirements for a STES system planning.

- The Decision Support Tool (DST) developed within the project is a user-friendly tool enabling users to get preliminary information on the design of a STES system. This tool may allow stakeholders to consider the STES systems as an option in their feasibility studies or new projects, helping to foster STES systems implementation across Europe. The importance and impact of the developed tool is remarkable, especially taking into account that there are almost no available tools for this purpose. So far, there was only one available tool that does not require a high level of expertise. The developed DST complements this tool extending the scenarios and boundary conditions that can be considered.

Together to these reports and tool the specific dissemination activities that have been carried out (listed in section 4.2.) should be as well mentioned, which aimed mainly at promoting the STES technology among the main stakeholders.

In general terms, it should be highlighted that one of the most important impacts of the EINSTEIN project for the STES market in Europe has been that in further countries than Germany and Denmark STES was regarded and that two pilot projects could be realized: in Poland and in Spain as national first-of-its-kind ones. This success supports the strengthening of awareness of STES technologies as one of the few sustainable and evident technologies for mid- to long term future heat market development in Europe.

4.2.- MAIN DISSEMINATION ACTIVITIES

The main dissemination activities are summarized in the following points:

- Project Website. www.einstein-project.eu.
- Project leaflet translated into German, Italian, Bulgarian, Spanish, Polish and Swedish.
- Organization of two Workshops to disseminate the technical results of the project:
 - Seasonal Thermal Energy Storage systems in District Heating and Smart Cities, 11th June 2015, San Sebastian, Spain. Workshop organized by Fomento San Sebastian and about 70 people attended the meeting. A total of eight presentations were shown in the event. Three of them were related to Einstein project.
 - "Energy Storage in SMART HOSPITAL DISTRICTS", 21-23 September 2015, Warsaw. Workshop organized by MAE. "Presentation of the demo sites in Spain and Poland: "EINSTEIN PROJECT: EFFICIENT INTEGRATION OF SEASONAL THERMAL ENERGY STORAGE SYSTEMS IN EXISTING BUILDINGS". Mr Bartosz Starioselec, Mostostal. Warsaw. A total of 93 people attended the meeting. After the event 42 people attended the visit to Einstein Zabki demo.
- Videos from the Zabki and the Bilbao demos
- "Disseminator" of the STES concept at Ekogunea Park, San Sebastian, Spain. Interactive presentation of the STES technology with two levels of technical knowledge, basic for children and families and technic for high school students. It has been translated into four languages: Spanish, Basque, English and

French. It contains videos from Zabki and Bilbao demo and links to be connected to both demos.

- Project Publications: Peer reviewed publications: 1
- Project Publications: Paper in Proceedings of a Conference/Workshop: 11
- Project Publications: Article/Section in an edited book or book series: 1
- Oral presentations to scientific events of the outcomes of the project: 25
- Oral presentations to a wider public: 2
- Booklet about the two Einstein demos in Warsaw and Bilbao.
- Interviews: 3
- Articles published in popular press: 2
- Posters: 3
- Exhibition in a Trade Fair: 1

4.3.- EXPLOITATION OF RESULTS

A total of nine results with potential exploitation have been identified. The most relevant issues regarding each of the identified result is as well shortly described

1. Advanced "Einstein STES" system to provide clean solar based heating energy (up to 80°C).
 - a. This is the main result of the project and the one that shows better feasibility to be exploited. Acciona, company which also plays the role of Energy Service Company, has included the STES technology developed in the Einstein project in its portfolio of technologies to be used for space heating as it is explained in the Exploitation Plan of the project (D8.4).
 - b. Potential customers: Einstein STES will be addressed to different clients:
 - i. Existing district heating operators.
 - ii. Public bodies (Local or regional governments) with obligation to become their buildings in near -zero emissions buildings, or involved in the retrofitting of districts (or even in the planning of new ones)
 - iii. Buildings which currently exists a thermal solar installation
 - iv. Industrial-plants where tanks that can be reused for energy storage.
 - c. Expected time to market: it is expected that the year 2020 can be a kind of set point for the market readiness of the first STES technologies for an autonomous market all over Europe that

further develop without subsidies

2. Design Guidelines for STES systems in existing buildings retrofitting.
 - a. This comprises the new knowledge that has been developed within the project regarding the design of STES systems.
 - b. Potential customers: ESCOs, construction companies, municipalities and cities, DH utilities
3. Expected time to market: immediate. The consortium partners will make use of the gained knowledge immediately after the end of the project, mainly in consultancy services. Innovative Heat Pump
 - a. A new heat pump that uses R245 as refrigerant, characterized by being able to work at higher temperatures (in both evaporator and condenser side) than conventional heat pumps for heating applications. The exploiter of this development is the partner Airlan.
 - b. Potential customers: stakeholders of the building sector, engineering companies, planners and installers
 - c. Expected time to market: several activities have been identified to be carried out before being ready to be launched to the market: optimize the unit for industrialization, achieve the EC marking, training of the commercial staff.
4. Optimal Control for Multisource Heating Systems including Dist. Grids
 - a. Renewable and waste energy can be efficiently incorporated into the real networks only by finding synergies between different energy sources. These synergies are often difficult to spot beforehand. A control approach which is able to spot the synergies automatically has been developed. Within the project a TRL4 has been achieved (it was tested in the simulation environment)
 - b. Potential customers: Developed algorithms are addressed to the municipalities and ESCO companies who aim to develop highly efficient district heating networks combined with electricity market.
 - c. Expected time to market: Further developments will depend on application for specific district heating network. It is foreseen that in 24 months it is possible to obtain TRL 9.
5. DST for selection, design and evaluation of STES
 - a. The main exploiter of this tool will be the partner Dappolonia, which expects to develop an updated version (Einstein DST 2.0). For the upgraded versions of the DST, a freemium pricing

strategy could be adopted where the additional tool functionalities are a paid service.

- b. Potential customer: the tool is addressed to engineering and construction companies. In particular, DST is addressed to users no expert in STES systems but with basic knowledge on HVAC systems, with the aim of facilitating and accelerating their duties.
- c. Expected time to market: At the end of the EINSTEIN Project (M48 – December 2015) the tool is available and ready to be exploited

6. Methodology for ground works related to STES implementation

- a. A methodology including guidelines for ground works related to STES implementation has been developed including a decision making process for the selection of the most suitable technique, step-by-step rules for applying the identified technique as well as for monitoring such activities. Since specific methodology for excavation/perforation activities related to the STES system implementation were not available up to now, this result can be considered innovative and useful in order to foster the development of STES systems in Europe
- b. Potential customer: Engineering and construction companies

7. Evaluation tool to assess the best combination of Einstein STES in coordination with others retrofitting measures

- a. This tool has been developed by Acciona and he is the interested partner in exploiting this result. The tool is available for free; further consultancy services based on the use of the tool can be provided under paid.
- b. Potential customers: consultancy, engineering and construction companies. In general any company in the building sector and in concrete involved in the retrofitting projects.
- c. Expected time to market: The tool is available from the end of the EINSTEIN Project (M48 – December 2015).

8. Design of tank for STES available since small volumes, low thermal losses and optimal costs

- a. The tank developed for the Bilbao Demos site includes thanks to its design, interesting features to become a competitive thermal energy storage (to be used together with an “Einstein STES” or in combination with other type of thermal facilities). Acciona will be the main exploiter of this result.

b. Expected time to market: this result is strongly related to the first one. It is expected that the year 2020 can be a kind of set point for the market readiness of the first STES technologies for an autonomous market all over Europe that further develop without subsidies.

5.- PROJECT PUBLIC WEBSITE. CONTACT DETAILS

The Einstein project website can be accessed at www.einstein-project.eu. Public deliverables and documents, videos of Polish and Spanish demos, the Decision Support Tool for STES pre-design and estimation of STES costs and the evaluation tool to assess the cost effectiveness of the different retrofitting strategies are available.

Partners that have participated in the consortium are:

- TECNALIA
- ACCIONA
- DAPPOLONIA
- MOSTOSTAL
- SOLITES
- UNIVERSITY OF ULSTER
- CIM-MES
- UNIVERSITY OF STUTT GART
- AIRLAN
- TNO
- SCANDINAVIAN HOMES
- GIROTZE
- ICOP
- ARCHITECTURAL SPIES
- FOMENTO SAN SEBASTIAN
- MAZOVIA ENERGY AGENCY
- FUNDACION ARTEAGA



For further details please contact the project coordinator:

Patricio Aguirre
TECNALIA
patricio.aguirre@tecnalia.com