



PROJECT FINAL REPORT

Grant Agreement number: 284745

Project acronym: DEECON

Project title: Innovative After-Treatment System for Marine Diesel Engine Emission Control

Funding Scheme: Collaborative Project

Period covered: from 1st September 2011 to 1st August 2014

Name of the scientific representative of the project's co-ordinator¹,

Professor Wamadeva Balachandran

Title and Organisation: Professor of Electronic Systems; Brunel University

Tel: +44 (0)1895 265774

Fax: +44 (0)1895 258728

E-mail: Wamadeva.Balachandran@brunel.ac.uk

Project website address: www.deecon.eu

¹ Usually the contact person of the coordinator as specified in Art. 8.1. of the Grant Agreement.

4.1 Final publishable summary report

Executive summary.

The emission of exhaust gases from shipping is one of the main sources of pollutants for people living in the proximity to harbours or in neighbouring coastal areas and had effects on human health and the quality of the atmospheric environment. It was recently estimated that ships produce at least 15% of the world's Nitrous Oxides, NO_x (more than all of the world's cars, buses and trucks combined), between (2.5 – 4)% of greenhouse gases, 5% black carbon (BC), and between (3-7)% of global Sulphur Dioxide (SO₂) output. Due to the increasing emission of exhaust gases from ships and its impact on health of people living in harbour and coastal zones, and on local ecosystems, recent international regulations are aimed at NO_x, SO₂, volatile organic compounds (VOC), and particulate matter (PM) abatement.

The aim of DEECON is to create a novel, modular, on-board, after-treatment unit that combines different sub-units, each of which is optimized to remove a specific primary pollutant (SO_x, NO_x, PM – including BC, VOC, and CO). This new integrated retrofit system will reduce the environmental footprint of existing and new ships well below the limits imposed by the current and envisaged future regulations, while giving EU marine industry a competitive edge.

Work has focused on the development of 2 key systems, a non-thermal plasma reactor for the removal of NO_x and VoC's and an electrostatic seawater scrubber for the removal of SO_x and particulate matter. Two stages of development have been achieved, first was a laboratory scale system to prove the concept and second was a pilot scale system to show the scale up and potential of a complete scrubber system. The pilot scale system is shown below (figure 1).



Figure 1 Pilot Scale system showing: Engine, PM monitor, Cooler, NTPR unit and ESWS

The abatement results achieved meet the expectations at the beginning of the project and are shown below.

	SO₂	NO_x	PM
NTPR	99%	95%	90%
ESWS	71%	0%	80%
TOTAL	99.7%	95%	98%
Target	98%	98%	99%

In addition to this, the consumed power and water for the system are significantly lower than current scrubber systems. Indeed DEECON has demonstrated that it may be possible for the system to receive more energy from the exhaust gas than it needs to run.

A range of further developments are needed in order to fully commercialise the system. The partners are fully committed to this and 3 distinct areas of work have attracted funding, both from national governments and internal funding.

Description of project context and objectives

The emission of exhaust gases from ships has been recognised as a major source of pollutants having a long term effect on the quality of the environment and causing a significant exposure risk to people living in proximities of harbours or in neighbouring coastal areas. **It was recently estimated, that ships produce at least 15% of the world's NOx (more than all of the world's cars, buses and trucks combined), between (2.5 – 4)% of greenhouse gases, 5% black carbon (BC), and between (3-7)% of global SO₂ output.**

This pollution is a combination of the amount of fuel used in this industry and its type. Ships mainly use high sulphur residual fuel oil that is a by-product of the refining process as it is cheap and plentiful.

In 2010 the International Maritime Organization (IMO) issued revised air pollution regulations in MARPOL Annex VI. These regulations limit the sulphur and nitrous oxide content of ship exhausts.

There are limits on the sulphur content of fuel to restrict SO_x and particulate matter emissions, and is applicable to all ships in service. The regulation specifies different limits for operating inside and outside an Emission Control Area for SO_x (ECA-SO_x) and these follow a stepped reduction over time, as shown in the figure below (Figure 2).

The area outside of ECAs is subject to world-wide limits set by IMO. The current world-wide sulphur limit of 3.5 % is more generous than typical fuel quality, which averages 2.7 % sulphur by weight. This limit changes, to a world-wide sulphur limit of 0.5 % in either 2020 or 2025 depending on a fuel availability review to be conducted in the interim.

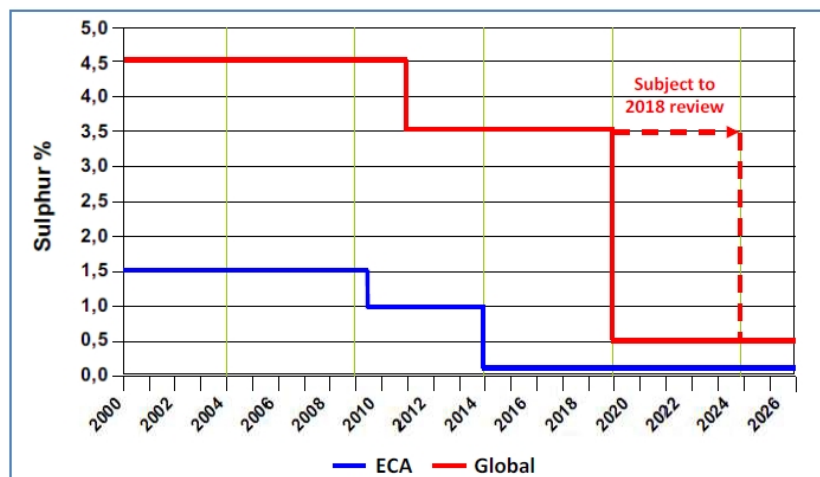

Figure 2: IMO timeline for reduction in fuel sulphur content

Four ECA-SO_x areas have been defined:

- Baltic Sea (SO_x, adopted: 1997 / entered into force: 2005),
- North Sea (SO_x, 2005/2006),
- North American ECA, including most of US and Canadian coast (NO_x and SO_x, 2010/2012),
- US Caribbean ECA, including Puerto Rico and the US Virgin Islands (NO_x and SO_x, 2011/2014)

From 2012 Emission Control Areas (ECA) have limited fuel sulphur content to 1% and from 2015 to this will reduce to 0.1%. Figure 3 below show geographically the ECA zones.



Figure 3 Current and proposed Emission Control Areas

However, the regulations allows for an alternative method of compliance that is as effective in terms of emission reduction as the prescribed fuel sulphur limits. This means that a ship may operate using a fuel with sulphur content higher than that allowed as long as an approved SO_x scrubber can reduce the SO_x emissions to a level that is equivalent to, or lower than, the emissions produced by compliant fuel. If a SO_x scrubber is fitted, it must be approved and verified as compliant in accordance with the IMO Exhaust Gas Cleaning Systems Guidelines (MEPC 184(59) – 2009 Guidelines for Exhaust Gas Cleaning Systems).

In addition to this there are also limits on the NO_x emissions of marine diesel engines. The limits are divided into three 'Tiers' whose applicability depends on the ship's construction date (or the date of installation of additional or non-identical replacement engines) and the engine's rated speed (n), as shown in Figure 4 and Table 1. Tier I and Tier II limits are applicable to engines installed on ships constructed on or after 1 January 2000, and 1 January 2011 respectively.

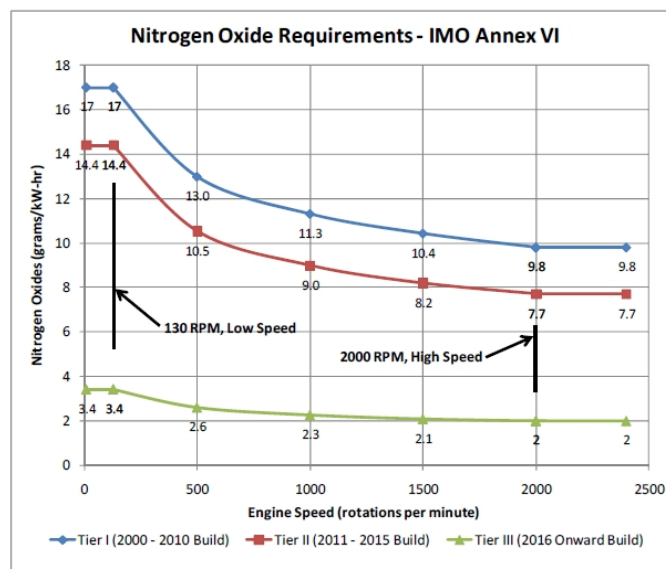

Figure 4 NO_x Tier limits from IMO Annex VI²

² Exhaust Gas Cleaning Systems Selection Guide, The Glosten Associates Inc, 22 Feb 2011

Table 1 NOx Tier limits with respect to engine speed and date of construction

	Rated Speed		
	Less than 130 RPM	131 Through 2,000 RPM	Greater than 2,000 RPM
Construction Date	(g/kW-hr)	(g/kW-hr)	(g/kW-hr)
Tier I. 2000 - 2010	17	$45 * n^{-0.2}$	9.8
Tier II. 2011 - 2015	14.4	$44 * n^{-0.23}$	7.7
Tier III. 2016 Onward	3.4	$9 * n^{-0.2}$	2

Subject to a review of enabling technologies, Tier III limits will apply to ships constructed on or after 1 January 2016 when operating inside an ECA-NOx. Currently, two ECA-NOx limits will be in effect in 2016; the North American ECA-NO_x and the US Caribbean ECA-NO_x.

Currently, most NO_x abatement is obtained by engine tuning. This operates the engine at a lower temperature. However, this also has the effect of reducing engine efficiency. Thus there is an opportunity for technology which will remove NO_x from exhaust gas.

The other main health and environmental concern from diesel exhausts is particulate matter. At present there is no regulation regarding these but there is an expectation within the industry that particulate emissions will be subject to certain limits in the future. Submicron particles have the biggest impact on health. However, current scrubber systems do not remove these very fine particles and measurement of such is very difficult.

Much of the world's fleet runs on Heavy Fuel Oil (HFO), this is a fuel that is a by-product of the refining process. This means that it is relatively inexpensive but it does contain significant quantities of sulphur, heavy metals, volatile organic compounds and other pollutants.

Changing fuel to low sulphur variants has a disadvantage, in that much of this type of fuel is already used in road transport. This will provide competition in the market and inevitably raise prices. Therefore, there is an economic case for developing retrofit scrubber systems to enable the use of heavy fuel oils.

The main objective of the DEECON project is to create a novel integrated on-board, retrofit, after-treatment unit for ships that combines different sub-units, each of which will be optimized to remove specific primary pollutants (SO_x, NO_x, PM, VOC and CO) and specifically designed for on-board application to allow an easy and fast installation on existing and new ships. This integrated system should reduce the environmental footprint of ships through the achievement of state-of-the-art removal of the target pollutants in order to reduce their emission factors well below the limits imposed by the existing and the future regulations.

It is expected that the designed system will have the following performance:

- Reduction of NO_x >98%
- Reduction of PM 90% in number,
- Reduction of PM > 99% by weight
- Reduction of VOC's > 80%
- Reduction of SO_x > 98%

To achieve this performance a brand new concept of scrubber, the Electrostatic Sea Water Scrubber (ESWS), for the abatement of sub-micron particulate matter, sulphur dioxide, other acid

gases and soluble organic compounds by using electrically charged seawater spray as a scrubbing liquid will be developed. In addition new processes for NO_x and VOC abatement based on the use of a novel Non-Thermal Plasma Reactor (NTPR) will be investigated.

To achieve these key objectives DEECON will develop a pilot-scale integrated system for removal of pollutants from marine diesel engine exhaust.

Description of the main S&T results/foregrounds

Introduction

Over three years the DEECON project has developed a range of technologies and integrated them into a pilot scale system to treat the exhaust of a 220kW marine diesel engine. The basic layout of the pilot scale system is shown below figures 5 and 6.

System Design

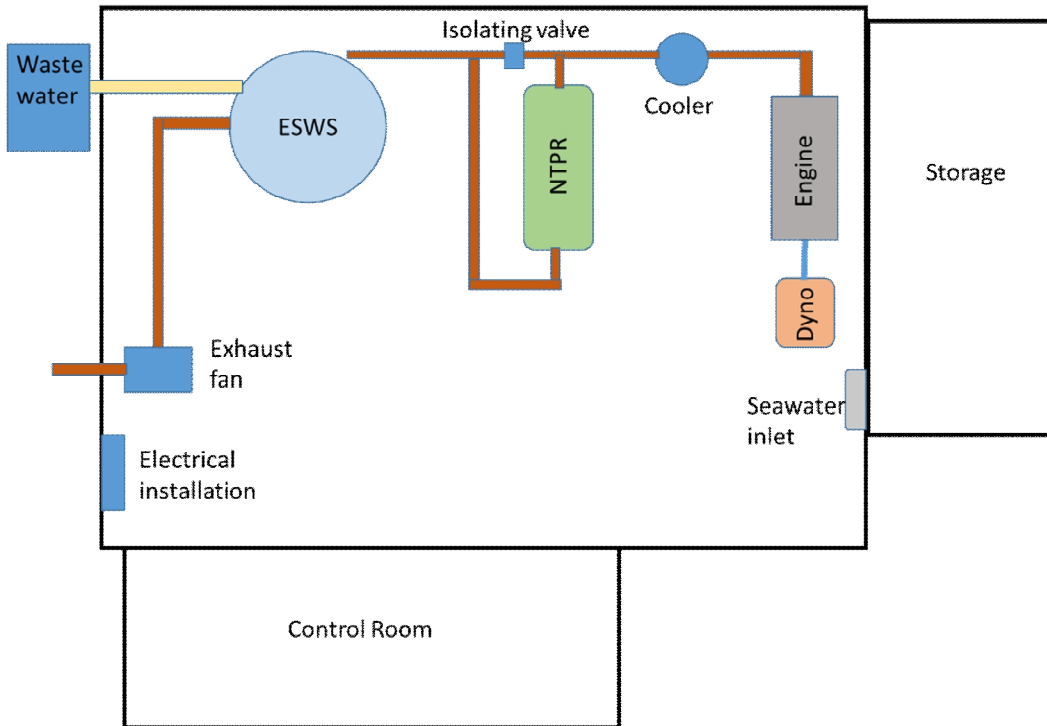

Figure 5 Layout of DEECON Pilot Scale System



Figure 6 Pilot Scale system showing: Engine, PM monitor, Cooler, NTPR unit and ESWS

Non Thermal Plasma Reactor (NTPR)

The NTPR utilises micro-wave generated plasma to create free radicals. Free radical are very short lived compounds that are highly reactive and will readily react with VOCs, CO, Carbon compounds, SO₂, SO₃, NO, NO₂ etc. Depending upon the conditions within the reaction chamber and the availability of a reducing compound, (e.g. fuel or carbon) the reactions can either cause compounds to reduce to their elements or to form larger compounds (e.g. NO_x to N₂ and H₂O is a reducing reaction whilst NO_x to HNO₃ is an oxidation reaction).

There have been some very encouraging results obtained with the prototype system. Lab scale results have witnessed NO reductions of almost 100% Figures 7 and 8. It should be noted that the results pertain to short periods of about 10 minutes. This is due to the difficulties in obtaining stable plasma in the current pilot scale design.

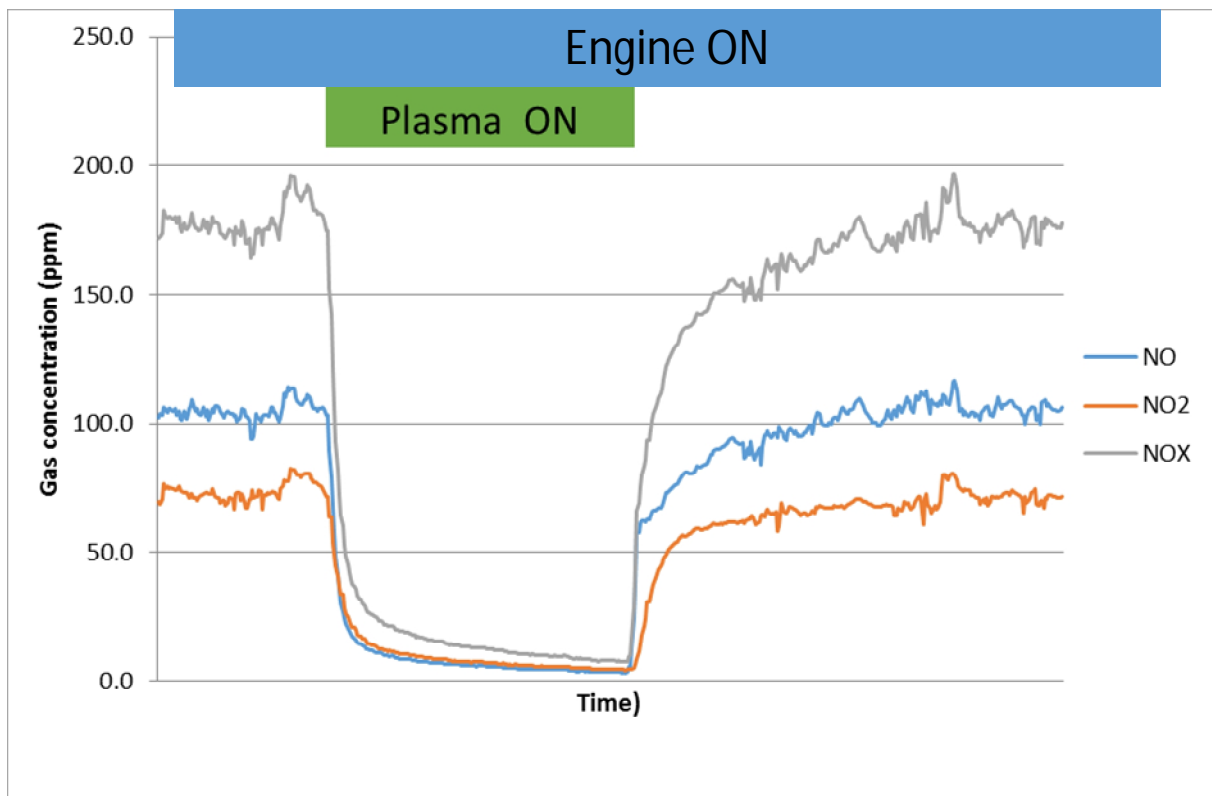

Figure 7 NO, NO₂ and NO_x reductions with NTPR

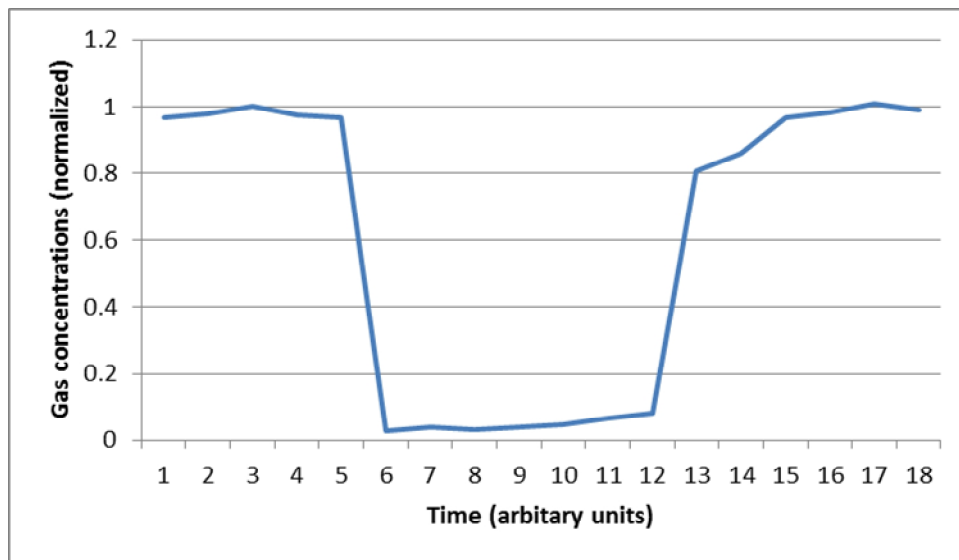
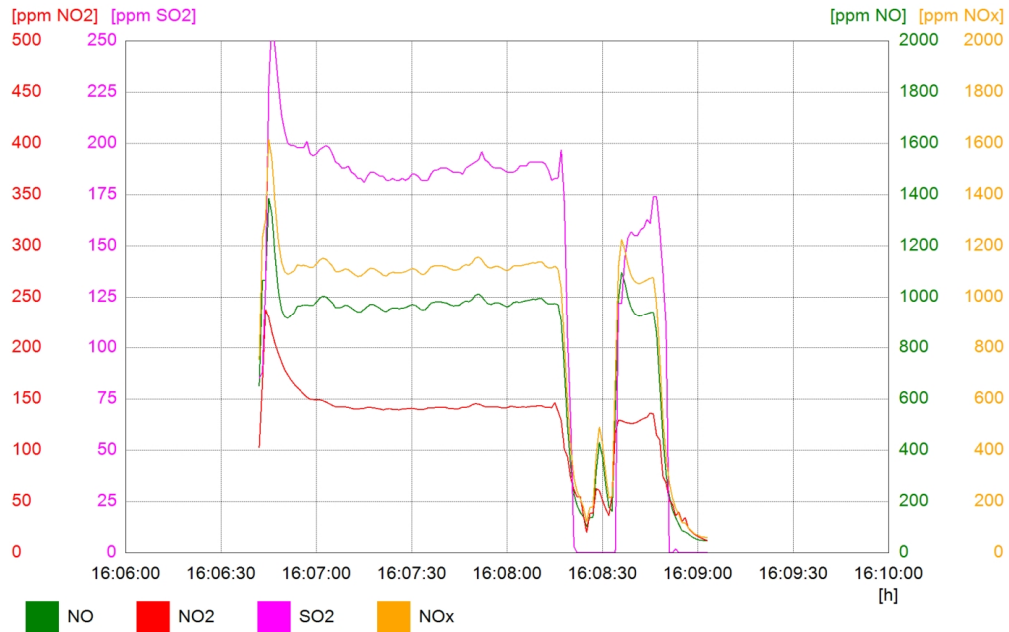

Figure 8 SOx reduction with NTPR

The pilot scale design included the use of an Electron Beam gun to initiate plasma. However due to some technical difficulties with the electron beam gun, it has not been possible to fully realise current NTPR potential in terms of stable plasma generation, with the higher volume flow rate of pilot scale system diesel engine. The NTPR unit is currently undergoing a redesign to overcome these issues.

The NTPR can also be used to remove particulates from the exhaust. It is particularly efficient at removing particle in the nm range which are the most hazardous to health. It does this in two ways; MW energy, without the generation of plasma, and with plasma.

Figure 9 below shows that reductions of up to 50% can be achieved with just the microwave energy impinging on the system.

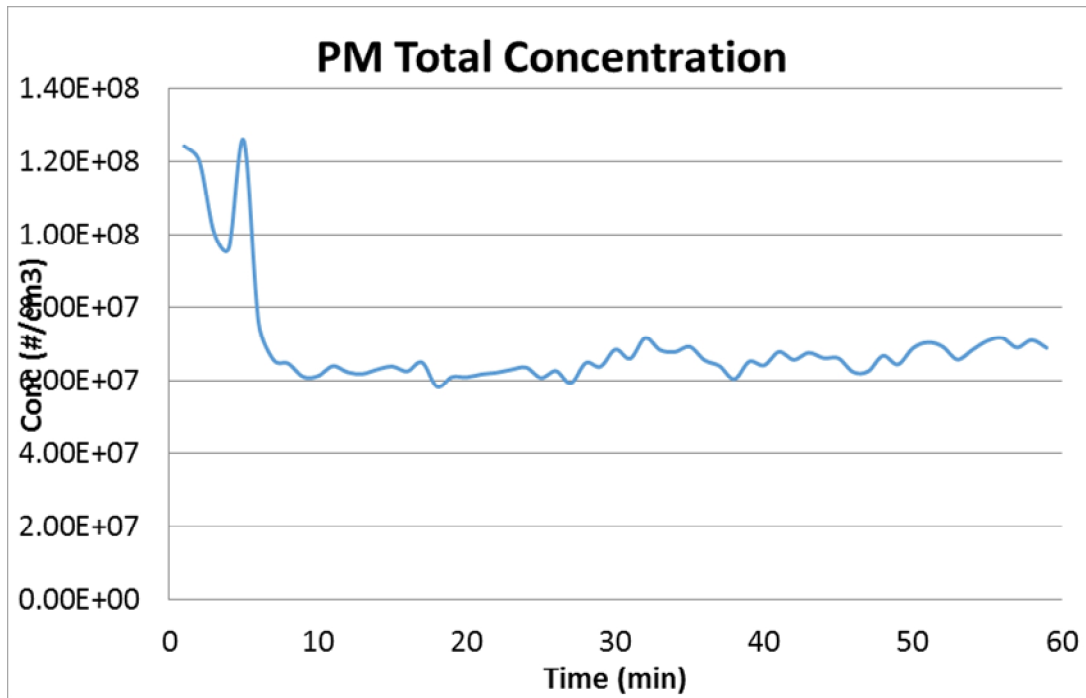

Figure 9 PM reduction with microwave only

In addition with the plasma on a reduction of up to 90% is achieved. This is shown in figure 10 below.

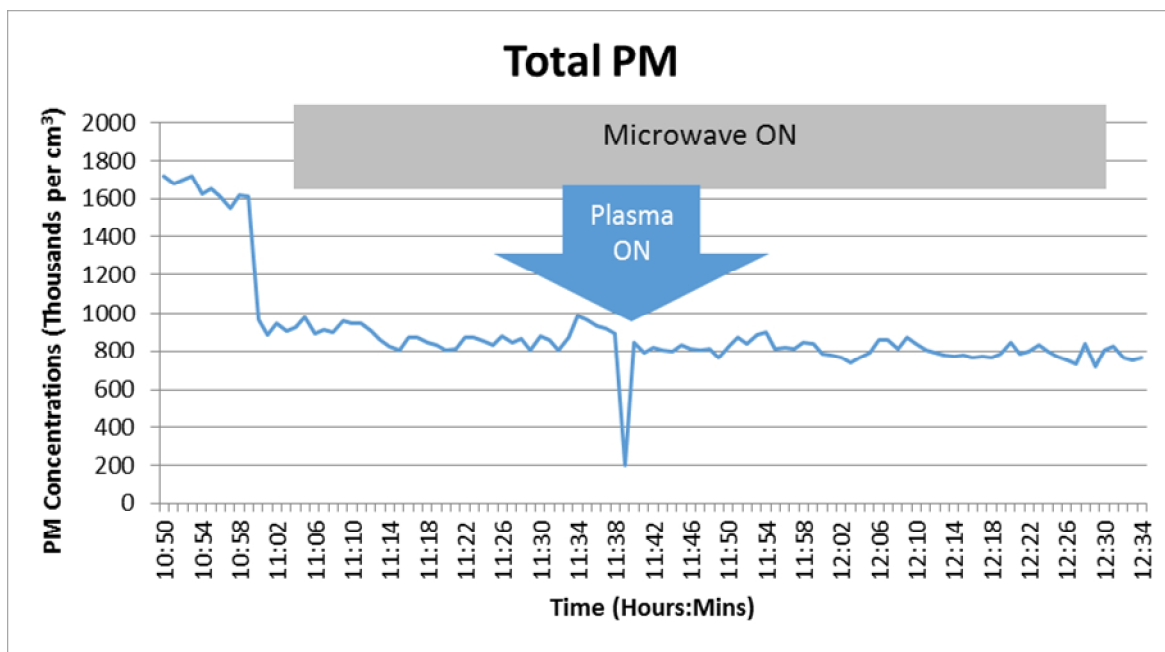

Figure 10 PM reduction with non-thermal plasma

The NTPR has a significant potential as a low energy device for removing VOC, CO, SO₂, SO₃ and NO_x without the need for chemicals. The application of plasma is well known in many industrial pollution abatement applications. Further work is planned to apply micro-wave technology with another method of initiating plasma thus avoiding the difficulties faced by using the EB device. Results so far indicate that NTPR technology will have a significant role to play in exhaust gas pollutant abatement.

ElectroStatic Wet Scrubber (ESWS)

Standard wet scrubber systems use high volumes of water to remove SO₂. They also have an effect on particulate removal. However the particulates removed are in the range of 2.5 microns and above. Studies have shown that it is the nano scale particles that are the significant risk to human health. The ESWS developed in DEECON uses a method of charging both the scrubbing water (sea water) and the particulate matter in the exhaust gas to significantly improve the abatement efficiency. Although the processes are well known the technology to achieve such charging in extremely challenging conditions has been successfully developed during the project. The ESWS has demonstrated reductions in SO₂ of 70% with a sea water flow rate of 10t/MW_{hr} (figure 11). This is considerable lower than the IMO Guideline standard of 45t/MW_{hr}.

The ESWS has also demonstrated extremely effective removal of ultra-fine PM (nano metre range). The reduction in the 50nm to 150nm range is over 80%. The removal of 1µm to 25µm range is 100% see figures 12 and 13 below.

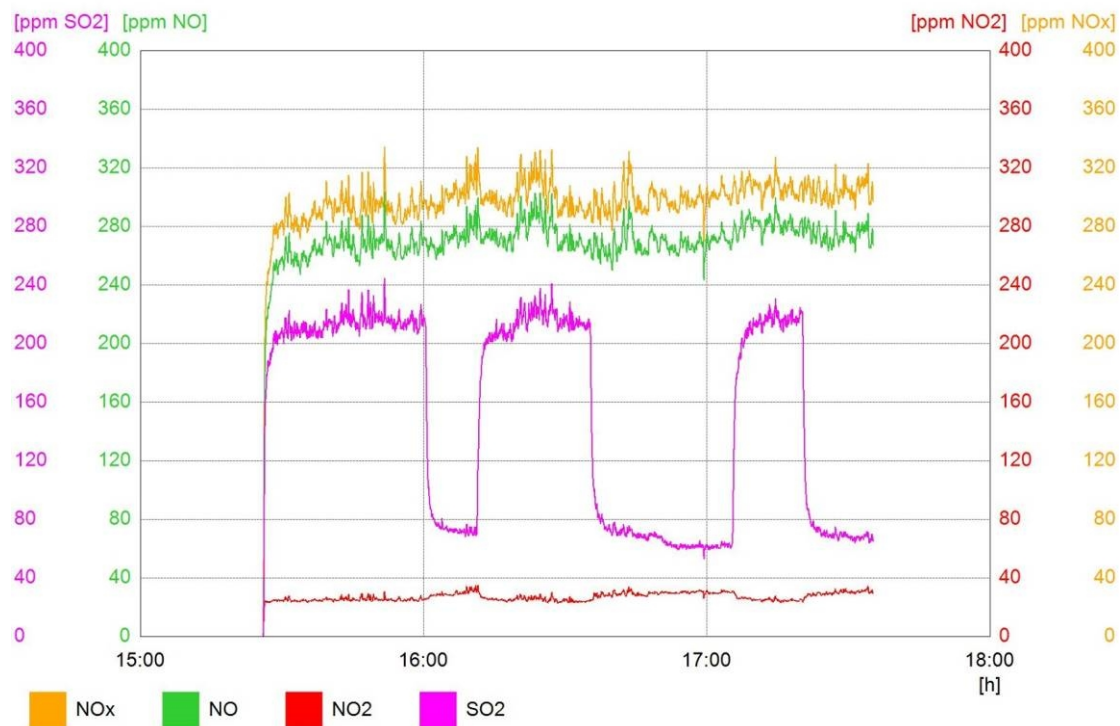

Figure 11 SO_x reduction with NTPR

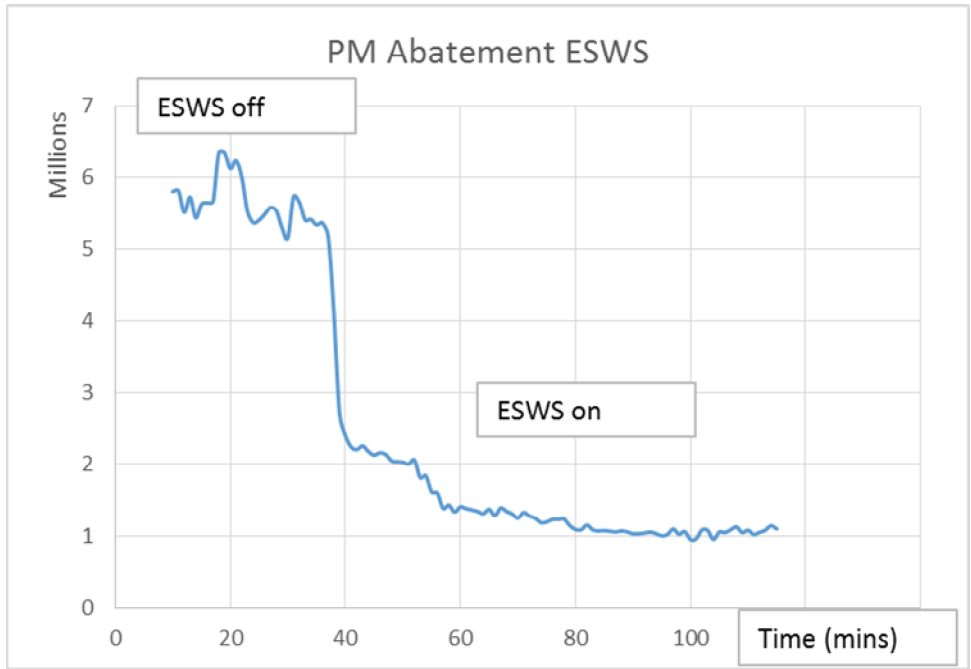

Figure 12 reduction of PM with ESWS

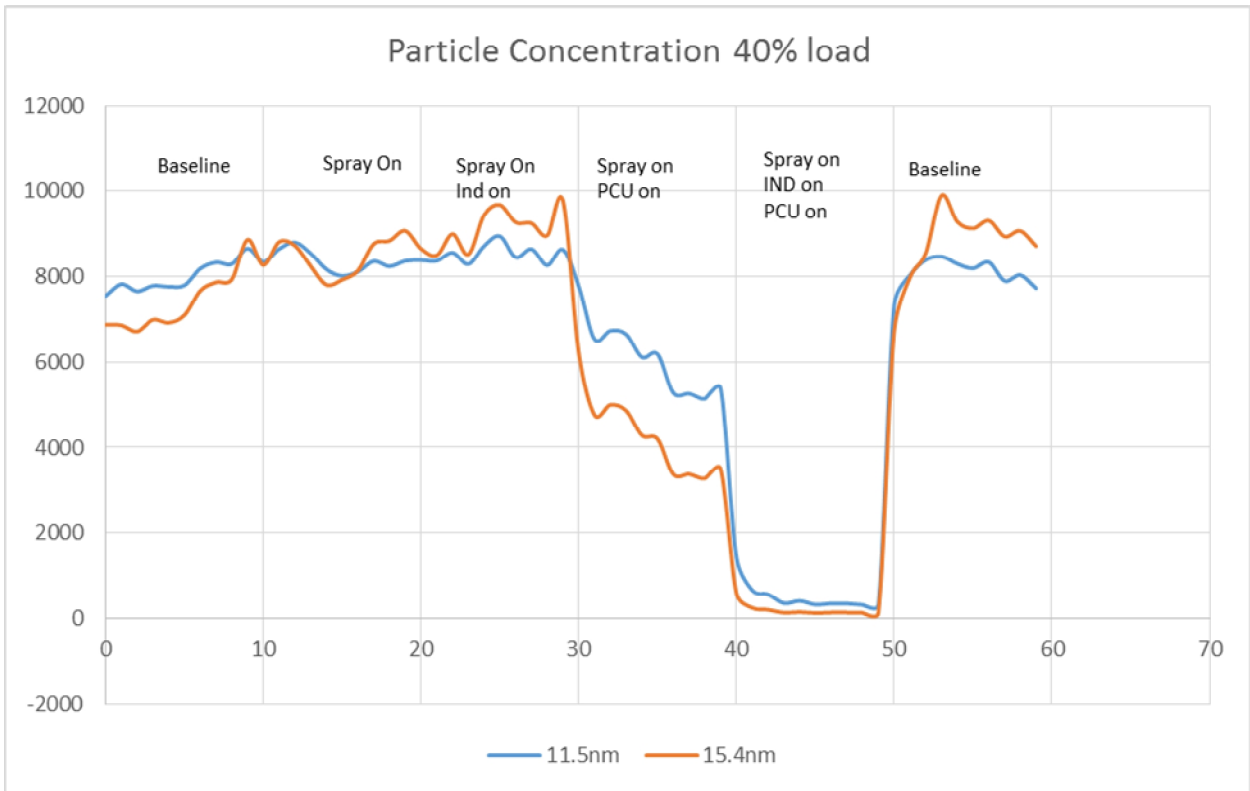

Figure 13 PM reduction with the different elements of the ESWS turned on an off

From the results shown above for the NTPR and ESWS it can be seen that elements are very effective at removing the pollutants of interest.

During the Pilot Scale experiments it was not possible to run the NTPR and ESWS together due to limitations encountered with maintaining a stable plasma. However given the performance figures for each it is possible to calculate the overall performance of the system and compare it to the objectives of the project.

	SO₂	NOx	PM
NTPR	99%	95%	90%
ESWS	71%	0%	80%
TOTAL	99.7%	95%	98%
Target	98%	98%	99%

Wash Water Treatment

The pilot scale system, requires the treatment of two water streams:

- Acid condensate from the cooler;
- Electrostatic SeaWater Scrubber washwater

The first stream is composed by sulphuric acid at pH around 2 and by water soluble organic compounds. In our experiments, these were mainly represented by benzaldehydes. The second stream is made by acid seawater (pH3) containing sulphates, a fraction of water soluble organics and the diesel particulate matter. The integration with the plasma unit will potentially generate significant concentration of nitrates in the wash water, with an average level of about 1000 ppm. For a 1MW engine, the two streams are about 430 l/h for the cooler while the ESWS water is about 10 m³/h.

The washwater treatment for the two streams should be kept separated, avoiding mixing the two currents. The two treatment units are based on adsorption and ion exchange processes, respectively, because of the needs to provide an appropriate removal of the target pollutants in the harsh marine environment and in light of the specific constraints of space allocation and limited maintenance.

In particular, the cooler condense should be treated to reduce the organic content, which is close to 20 mg/L in the DEECON experiments. This can be performed by granular activated carbon adsorption, using the hydrophobic nature of the organics. This method is well understood in the civil and industrial fields and the process layouts and engineering are consolidated. During the DEECON experiments, the concentration of particles in the condensate was quite low: we envisage that most of the particles are blocked on the cooler exchange surfaces. The suspended particles are large and heavy, mainly composed of inorganic ashes. The condensate can be filtrated on sand filters before

adsorption. However, the same activated carbon filter can be used to retain the suspended particulate matter. The exhaust activated carbon can be regenerated by re-heating at 400°C or being disposed on land. The best option depends on the vessel service route. If the granular activated carbon is disposed, the use of the sand filter can be avoided. Eventually, standard pH neutralization can be performed on the adsorption column outflow. The organic removal in liquid is actually unaffected by pH and the carbon treatment generates an increase of solution pH.

The design of the cooler condense adsorption treatment can be considered as definitive since the process information are sufficient to design industrial unit of any scale.

The main issue of washwater pollution is the presence of nitrates, being the organic content negligible and the mass of suspended particulate below limits. The treatment of scrubber washwater is complicated by the scarce availability of experiences on high concentration nitrates removal in seawater and to the contemporary presence of sulphates deriving from the ESWS operation. After screening of several process, the use of strong anionic resins was selected as the best available option.

Although the process design is consolidated, there were no data on nitrate removal in conditions similar to scrubber washwater. Tests on the scrubber washwater artificially polluted with nitrates allowed achieving sufficient data for process design. One critical issue in the developed process is the need to regenerate the resin. Tests reveal that the exhaust resin needs 5 bed volumes of NaCl 0.1 M solution for regeneration followed by a similar volume of freshwater to restore its nitrate uptake capacity. To date, tests on brine generated from on-board freshwater production plant as potential regenerating solution are not available.

Power Requirements

One of the key elements of this new technology is the amount of engine power it uses in the scrubbing process. To this end the system has been designed to explore the option of using lightweight fabrications with an inherently lower build cost. With the conditioning of the exhaust gas to a temperature below the SO_x dew point the remaining gas flow has a reduced volume and low temperatures enabling a different approach to gas management/containment. The energy lost in the exhaust gas conditioning unit will be the subject of a future energy recovery development possibly recovering both sensible and latent heat for conversion to mechanical energy. The reduced requirement for sea water (25% of the typical demand of a normal open loop scrubber) reduces the pumping energy requirements. The use of effective exhaust gas pre-treatment in the exhaust gas cooler and the NTPR has reduced the water treatment requirements and concentrated contaminants enabling easier separation prior to sea water discharge.

Analysing the electrical power needed to run the ESWS and NTPR it can be calculated that the ESWS required only 1% of the engine power and 2% for the NTPR.

As part of the gas conditioning system the exhaust gas needs to be cooled from a temperature in excess of 300°C at the engine to approximately 70°C at the NTPR or ESWS. The cooler employed in DEECON does this very effectively. Calculations show that about 2/3 of this energy is recovered in the water surrounding the cooler. This energy has the ability to be recovered into mechanical and/or electrical energy. Even if this was only at an efficiency of 30% it would be more than enough to run the scrubber system.

Potential Impact

The DEECON project is primarily a technological development programme with the aim of reducing pollutants from ship exhausts. There are however a range of major impacts, scientific, commercial, economic and social. The potential of these is described below.

Scientific

There have been considerable advances in the state of the art in all aspect of the project, the list below identifies the key elements:

- Numerical model for NTPR design
- The use of a non thermal plasma for exhaust treatment
 - NOx abatement
 - SOx abatement
 - PM abatement
- Modelling of ESWS for design and scale up
- Electrostatic methods for particulate removal
- Electrostatic methods to higher efficiency SOx removal
- Design methodologies to reduce the weight and energy consumption of the system
- Incorporation of gas cooler technology to introduce energy recovery
- Analysis of wash water composition
- Analysis and design of wash water treatment systems

Publications and Conferences

DEECON has produced 5 peer reviewed papers with an additional 2 papers accepted for publication but not yet published.

In addition to this DEECON has presented at over 27 scientific conferences and presented and 16 industrial conferences and workshops.

DEECON has produced flyers detailing the project and progress made, which have been distributed at a range of conference events.

Industry Engagement

DEECON has actively engaged with the shipping industry throughout the project. This has included discussions with ship owners and operators as well as current scrubber and engine manufacturers. This engagement has been extremely useful in helping to define the exploitation roadmap.

DEECON has also presented the NTPR and ESWS technology at a range of events this includes:

- Lloyds Register courses
- Industry specific conferences

- Technology open days

The pilot scale system was introduced and demonstrated to a range of marine sectors including the press. From this up to 5 press articles either have or will be written.

Commercial

Significant commercial potential has been generated by the DEECON project. At the end of the project the technology is not ready for direct commercialisation but will require an additional phase of development. The partners are fully committed to this and have implemented a roadmap for commercialisation this includes the raising of finance.

The novel retrofit scrubber technology is being taken further by the partners in 3 distinct areas:

1 - Brunel, SMS and iXscient are collaborating in a UK Technology Strategy Development scheme to produce a retrofit NO_x abatement scrubber for coastal water shipping. The value of which is £1.2M, 40% of which will be paid by SMS, further indicating the level of commercial support.

The project Marine Exhaust Gas Treatment System (MAGS) objective is to create a novel integrated on-board Non-Thermal Plasma Reactor (NTPR) after-treatment unit for ships that combines different sub-units, each of which will be optimized to remove specific primary pollutants (NO_x (NO+NO₂), PM, VOC and CO) from low sulphur diesel fuel. It will also look at heat recovery systems to minimise the use of power. The NTPR will be a retrofit specifically designed for on-board application to allow an easy and fast installation on existing and new ships. This integrated system will reduce the environmental footprint of mid-size coastal and inland waterway marine vessels through the achievement of state-of-the-art removal of the target pollutants in order to reduce their emission factors well below the limits imposed by the existing IMO defined limits on NO_x and VOC emissions and revised MARPOL Annex VI regulations and for future regulations. MAGS is expected to achieve emissions factors comparable with on-road diesel engines for motor transport. The consortium will deliver a manufacturing supply-chain for key components of the NTPR system and will target the US "brown water" fleet and small northern European vessels that operate in coastal and inland waterways using diesel fuel. The project will be delivered in 3 stages: STAGE 1 - Design, construct and test an integrated pilot scale system using a 300 kW diesel engine and evaluate plasma activated catalysts for the conversion of N₂ from NO_x, STAGE 2 - Carry out on-board testing of a full- scale system including; a cost/benefit analysis, preliminary life-cycle analysis and validation of the system performance through an independent certified testing authority, STAGE 3 - Develop a generic design model of the new integrated MAGS TECHNOLOGY for easy and fast retrofit on target market (i.e. coastal tankers, bulkers, offshore supply vessels, tugs, inland barges, small ferries, etc.)

The project value is £1.2M with 40% being funded by SMS. Part of the requirement for project funding is that a prototype product is ready with 2 years. This project is due to start in December 2014.

2 - Partners RAFAKO and PAS have collaborated to develop the ESWS head including the special particle charging unit and the anti-contamination system as well as the water spray and induction system, all of which have been designed, developed, and tested. These partners have filed a patent on this knowledge PCT/PL2014/000095.

RAFAKO have identified a commercial opportunity to develop the ESWS work for implementation into the marine and onshore sectors.

It is recognised as described in previous sections that further research and development is necessary to implement a system into production.

Currently RAFAKO is financing these developments via an in house research and development programme. In parallel to this other sources of funding are being sought.

The implementation activities will include the testing the prototype in real world conditions. The external financial and equipment resources will be used for this (by investors, business partners, etc.).

The final product intended for the marine market, will be ready to offer commercially in year 2017. The estimated cost required to achieve this is about 5-10M EURO.

RAFAKO is not only focuses on marine industry. There are perspectives in onshore industries as well. Particulate matter in exhaust gases of thermal and power production from oil boilers are one of the biggest environment pollution factors.

The electrostatic scrubber technology also has potential as a modern wet or semi-dry dedusting technology. It has also potential in desulphurization systems modernization, where brown or hard coal is burned. The applications of electrostatic scrubbing are very extensive. RAFAKO as a leader market in environment protection system has the capability and experience to be a market pioneer and reliable supplier of the project results.

3 - UNINIA and VTS are collaborating to develop further washwater and scrubber systems.

The DEECON project allowed UNINA to achieve significant know-how in many research fields among which are:

- The design and scale up of wet electrostatic scrubbers;
- The formulation of innovative catalysts for SCR unit on-board ships;
- The design and scale up of washwater treatments for the treatment of wet electrostatic scrubbing integrated with non-thermal plasma units;
- The design of quencher and coolers for the cooling of diesel exhaust gases;
- Design criteria for naval installation of scrubbers.

This know-how will constitute the basis of following academic research in UNINA. The research will be focused on the design and optimization of new scrubber units as well as new electrified sprays and charging units. Specific collaboration with the CNR-IRC is ongoing to upgrade the formulation of the SCR catalysts and design specific ESWS-SCR integrated units at prototype scale.

VTS has the experience and the knowledge to design, build and install scrubber systems to meet the new and more restrictive regulations on the emissions from diesel engines. Therefore, it is the intention of VTS to exploit the knowledge gleaned by the FP7 project DEECON related to the ESWS and on the Wash Water Treatment (WWT). VTS is open to a cooperation and future exploitation of the results within the European partners, or only with Italian partners such as University of Naples Federico II and with the Istituto di Ricerca sulla Combustione CNR-IRC.

Thanks to the close cooperation with the University of Naples Federico II and to a recruiting policy from the academic world, VTS is currently working on the design and the construction of a new ESWS prototype. This system will be the result of an Italian industrialization proposal started in June 2014 called RAIN.

This project addresses the required steps to develop an ESWS technology ready to face the offshore market within the next two years. The objectives of RAIN are:

- Develop a compact scrubber with an optimized fluid dynamic;
- Develop and optimize new charging units;
- Develop a new and more reliable anti-contamination system;
- Develop a Wash Water Treatment tailor made on the specification of the wastewater;
- Develop design criteria to minimize the water consumption;
- Running experimental tests on real benchmark engine.

It is expected that these activities should be concluded within 24 months.

To support this activity and to translate knowledge gained from academic pursuit into industrial application VTS have recruited Dr Luca D'Addio from UNINA.

Standards / Regulation

Currently there are no standards or regulation regarding the particulate emissions from ships. The area is addressed in Emission Control Areas by the use of low Sulphur Marine Gas Oil. It is also extremely difficult to measure particulate output especially in the sub-micron range which is particularly hazardous to health.

Within DEECON two technologies have been developed that address this. The ESWS and NTPR have been demonstrated to significantly reduce the sub micro particulate from exhaust gas and UNIN have a developed equipment to measure the sub micron particulate distribution.

This leads the way to be able to introduce regulation in the area.

Partner SMS is writing a paper on this for presentation to the IMO, which, it is hoped, will then form a part of any discussion regarding new standards in addition to MARPOL annex VI on particulate abatement.

Societal

International shipping is and will continue to be one of the key elements that maintain economic growth and potential. Currently there are no viable alternatives to burning fossil fuels for motive power. Traditionally ships have been run on residual fuel elements from the refining process but recent regulation (MARPOL Annex VI) has limited both the sulphur content of fuel and the NO_x emissions from engines. This means that shipping will need to use more refined fuel which is currently widely used in road transport. This will have the effect of increasing the price of this commodity, estimates for this are an increase of about 20%.

The use of DEECON technology will enable the continued use of high sulphur less refined fuels whilst still providing for the required emission limits.

Another factor to consider, beyond the general environmental concerns, is the public health issue for those living in harbour or coastal areas. The European Community has made health and well-being one of its top priorities. While health is not an immediate application of the DEECON project, the technology developed will have a substantial impact on the level of pollution in harbour or coastal areas, in particular reducing the level of submicron particulate matter which is ingested by people living in these areas and which has been demonstrated to exert a toxic action upon chronic exposure in terms of development of asthma, bronchitis, inflammation and fibrosis. It was also found that long-term exposure to urban air pollution (containing soot) increases the risk of coronary heart diseases, acute vascular dysfunction and increased thrombus formation.

The proposed new cleaning system is specifically designed to remove NO_x, SO_x, and, for the first time, VOC, CO and submicron PM. While consistent removal of NO_x and SO_x can be achieved with existing technologies, the novelty of the proposed cleaning system is its effectiveness in removing the PAH fraction of the VOC and the fine, submicron particulate matter.

Economic Potential

A preliminary cost/benefit analysis for the adoption of the proposed retrofit unit can be derived by comparison with the switch-fuel option proposed by IMO. For example, Calais to Dover Ferry Service employs vessels with an installed power of about 25MW. These vessels typically consume 20,000 tonnes of fuel per year. Presently operating on reduced sulphur content (1.0%S) fuel has an

additional cost per ship compared to operating on HSFO of around \$600,000/year. From 1st January 2015, to meet 0.1%S content, the fuel of choice will have to be diesel oil (in the absence of retrofit solutions). As a result, each ferry will face an annual fuel bill increase of between \$5M and \$10M depending upon the difference in price premium between diesel and HSFO. At \$10M saving per annum for continuing to use HSFO technology, and assuming an installation cost of \$3M, there is a typical payback for a retrofit installation of about 16 weeks.

The economic potential for those who can produce a scrubber system that is both efficient, light weight, small footprint and low power is very large.

- Some 2,000 vessels trade permanently in the European ECA. Of which around 500 vessels have installed power >10MW and will be using HSFO. At least 50% of these vessels will require switching to low sulphur diesel or use scrubbers.
- In 2020 the market potential is around 60,000 vessels with >2.5MW installed power. Of this fleet circa 30,000 to 40,000 vessels will be less than 20years old.
- In 2020 the new build rate of ships with >2.5MW of installed power will be around 2,000 vessels/year.