

PROJECT FINAL REPORT



Grant Agreement number: 280676

Project acronym: DIBBIOPACK

Project title: Development of Injection and blow extrusion molded BIOdegradable and multifunctional PACKages by nanotechnology: improvement of structural and barrier properties, smart features and sustainability

Funding Scheme: Large Scale integrating Collaborative Project, FP7-NMP.2011.LARGE.5

Period covered: from March 2012 to February 2015

Name of the scientific representative of the project's co-ordinator, Title and Organisation:

Coordinator: AITIIP – Berta GONZALVO

Tel: (+34) 976 46 45 44

Fax: (+34) 976 47 61 87

E-mail: berta.gonzalvo@aitiip.com

Project website: www.dibbiopack.eu

4.1 Final publishable summary report

EXECUTIVE SUMMARY

DIBBIOPACK concept is to develop multifunctional packages in a wide range of processes (injection & blow extrusion) which improve the structural and barrier properties; introduce smart features and increase sustainability using nanotechnology.

DIBBIOPACK develops new bio-based materials specially adapted for the development of a wide range of containers or packages (films made by extrusion laminating, trays or lids developed by injection moulding and bottles performed through extrusion blow moulding technologies). It also improves the thermal, mechanical and barrier properties of these packages through nanotechnology and innovative coatings.

DIBBIOPACK aims at integrating different intelligent technologies or smart devices to provide more information about the products and the processes to the packaging value chain; increasing safety and quality of the products throughout the supply chain and improving the shelf-life of the packaged products.

It aims at three objectives:

1. Reducing the environmental impact, combining 100% biodegradable functionally different materials with a reduction of energy consumption and material use promoting the sustainability as a target.
2. Improving package performances as barrier properties or thermal resistance of bioplastics and processability, all them through materials formulation and processes combination and optimisation.
3. Assuring the multifunctionality of the package, developing biodegradable smart nanodevices adapted to the package and the safety using IML to facilitate the separation between product and nanomaterials.

Description of the work performed since the beginning of the project and the main results achieved during the project

- Specifications from end users and processes
- Decision on the demonstrators to be used in the project.
- Identifications of critical parameters of the processes.
- Preparation of final formulations of PLA in order to improve its characteristics, adding plasticizers and nanoadditives, specific to each application.
- Prototype production of material batches by injection moulding, blow extrusion and film blowing.
- Manufacturing and tests on the testing moulds with natural PLA and with the new formulations, and optimisation of the parameters for the new formulations.
- Final process parameters optimised for the final materials and the different applications
- Material screening and evaluation of the ORMOCER®-based antimicrobial coating materials from the state-of-the-art
- Development of new biodegradable antimicrobial coating materials.
- Developed plasma technology for enhancement of biodegradable polymers barriers.
- Completely characterised IML technology processing behaviour of new biodegradable materials.
- Optimised IML process parameters using final material formulation and biodegradable labels.
- Development of ultra-sensitive O2 sensor, RFID tag and reader.
- Set up of 3 pilot plans and its optimisation
- Matrix of materials, processes and devices allowing the development of an expert software to guide and inform the user on the possibilities using the materials on the project
- Specific computerised tool to measure efficiency and applicability of integrated systems

- Questionnaires for data collection of LCA studies and Nanosecurity issues. Reports on LCA.
- Reports on migration
- Reports on ecotoxicity
- Reports on biodegradation
- Validation of the end users using their own test methods and contents.
- Dissemination strategy and external image (web, brochure, poster).
- IPR and commercialisation plan based on several workshops and dedicated meetings

Expected final results and their potential impact and use

Exploitable results concerning new material development, new processes optimisation, new devices and new packages development:

- KER 1a: Materials formulations for specific processes
- KER 1b: bioORMOCER
- KER 2a: Processes adapted to be used for Direct Industrial Use or as a service for other companies.
- KER 2b: Coating on films
- KER 3: Oxygen sensor
- KER 4a: Food tray
- KER 4b: Pharma bottle
- KER 4c: Cosmetic jar

Scientific and technological impact: the project knowledge produced from different fields will be applicable in other technological fields.

Nanotechnology	Nanoparticles dispersion in bio based matrix	automotive field, composite materials for wind turbine blades
	Nanoparticles compatibilization to bio based matrix	
Hybrid polymers	New bio-based hybrid polymers development and optimisation	automotive field, composite materials for wind turbine blades
	New bio-based hybrid polymers functionalization	
Technology adaptation	IML process adaptation in biodegradable materials	High end credit cards, decorative bottles, electronics,
	Supercritical CO2 process adaptation to injection and blow extrusion moulding	ECO-Electric cars (lighter, biodegradable, etc.)
	RFID system association with chemical sensors	Automotive (intelligent features in cars), households, clothes, etc.
	PLA adaptation to injection	New parts to automotive, household, clothes (buttons, etc.)
	PLA adaptation to blow extrusion moulding	New parts to automotive, toys, etc.

Summary description of project context and objectives

Biodegradable composites developments

In order to develop packaging materials meeting the expectation of industrial partners for the Pharmaceutical, Cosmetic and Food sectors, and integrating smart devices merging the multiple targets of DIBBIOPACK project, the consortium cooperated to the definition of technical and economical requirements for DIBBIOPACK products considering the availability, sustainability and cost of raw materials and additives. Preference has been given to materials produced by the partners in the consortium with low impact on environment and health considering also safety in production and use of polymers and additives such as plasticizers and nano-additives.

The biodegradable polymeric matrices were selected by screening different grades of polylactic acid and then blending with several different types of plasticizer based on oligomers of polylactic acid, thus highly biodegradable and sustainable. Some functionalised plasticizers were produced, and tested appositively for the development of DIBBIOPACK products. The selection of most promising formula was performed considering the thermal stability of the material and their possible degradation during processing, coupled with processing ability and the best performances in terms also of mechanical properties, for the production of items by injection moulding (jars), blow moulding (films) and extrusion blow moulding (bottles). As well, an extensive screening has been made on several types of inorganic nano-additives that allowed the selection of best performing formula and processing conditions for the production of nanocomposites. The formulations have been selected on the basis of processing, mechanical and barrier properties and then have been produced by extrusion as master batches on industrial scale and tested by industrial partners for pilot scale production of the prototypes. The continuous feedback and cooperation among the partner allowed a positive achievement of several compositions and processing conditions covering the full range of products targeted in the project (films, rigid packaging, thermoformed items, and bottles).

Processes development, characterisation and optimisation

Processes development, characterisation and optimisation involved adaption of injection moulding, blow extrusion moulding and film extrusion process for newly developed Dibbiopack materials. Technological window and processing parameters were defined with extensive testing moulds and virtual simulations. Supercritical fluids technologies (N₂ and CO₂) for biodegradable nanocomposite materials were adapted to the injection moulding process to obtain a reduction in the plastic magnitude and to study the sustainable and profitable alternative routes for dispersion and intercalation of nanoparticles in plastics, avoiding functionalized nanoparticles usage. Plasma activation technology and hybrid polymer coatings for biodegradable substrate materials were investigated to obtain high-end ultra-barrier films and labels. In mould labelling technology was optimised for industrial scaled operations on injection and extrusion blow moulding to achieve a high quality surface and to improve barrier properties on injected and blow extrusion moulded packages.

Integration of biodegradable composite materials, processes and multifunctional smart devices

This part of the project aimed to the successful and efficient integration of all the developments previously done, the biodegradable materials, the optimized processes and the smart devices.

On this regard, firstly the best conditions combinations regarding technical parameters, end users and consumers expectations, safety and sustainability were selected using software.

Finally, the set-up of the pilot lines based on the previous combinations selected and aiming to the three sectors, were performed and evaluated, as well as the manufacturing of the first demonstrators were checked as valid or not for the WP5 tests. These pilot lines were expected to be three, one for each sector and end user:

- A food tray, manufactured by injection moulding with a superb barrier film as a lid, internal in-mould labels with antimicrobial effect, and a RFID oxygen sensor.
- A cosmetic jar, manufactured by Injection Moulding using foaming agents, with external and internal labels
- A pharmaceutical bottle, manufactured by extrusion blow molding and its screwed cap made by injection moulding. In mould label on the outside was also compulsive.

Life cycle analysis and assessment of the packaging sustainability

The aim was to assess the global life cycling of the packages and their own processes, in terms of biodegradability, environmental and health & safety impact. In particular, the specific objectives were the following:

- To set-up a traceable process for the record of technical and economic specification and requirements of the new materials and related processes collected in WP1;
- To study the biodegradability and possibility of organic recycling or composting of developed functionalised packages;
- To perform an eco-toxicological evaluation of developed materials;
- To assess the environmental impact originated from the new products compared with conventional ones using LCA technique;
- To evaluate the economic feasibility using LCC approach;
- To assess Health & Safety impact on workers and users/consumers;
- Propose recommendations for integrated recycling solutions based on existing European waste management systems.

Assessment of the packaging sustainability, LCA, LCC and ecotoxicology

The aim was to assess the global life cycling of the packages and their own processes, in terms of biodegradability, environmental and health & safety impact. In particular, the specific objectives in WP6 were the following:

- To set-up a traceable process for the record of technical and economic specification and requirements of the new materials and related processes collected in WP1;
 - To study the biodegradability and possibility of organic recycling or composting of developed functionalised packages;
 - To perform an ecotoxicological evaluation of the newly developed materials;
 - To evaluate the ecotoxicological properties of the composted materials
- To assess the environmental impact originated from the new products compared with conventional ones using LCA technique;
 - To evaluate the economic feasibility using LCC approach;
 - To assess Health & Safety impact on workers and users/consumers;
- Propose recommendations for integrated recycling solutions based on existing European waste management systems.

Description of the main S&T results/foregrounds

WP1 - BIODEGRADABLE COMPOSITES DEVELOPMENT

WP1 activities have been mainly focused on the production, first at lab-scale and then at pilot and industrial scale, of bio-polyester based nanocomposites optimized in terms of morphology and thermal features, suitable to be employed for rigid and flexible packaging in the different applications required by end-users involved in the Consortium.

To achieve these targets, different research and technological phases have been assessed by combining the activities of all the partners taking part to this WP.

1) *Characterization and selection of polymers and additives components at lab-scale.*

2) *Selection of best performing formulations and settings for scale up production*

A planning and screening of the best performing compositions addressing the technical requirements defined at the beginning of the project has been performed. This has been based on results from the characterization of plasticizers made available by CQSA, and of the nanofillers (ranging from 2D to 1D and with different structural composition and aspect ratios) made available by Avanzare. The selection has addressed also the polymer matrices stated as interesting for the whole project, and has benefitted from the specific competences and previously achieved results of INSTM and CNR on the preparation and characterization of bio-plastic nanocomposites. Different plasticizers ascribing to the ester oligomers families having different molecular weight, and end-carboxyl content functionalities (Glyplast OLAs family) and /or low molecular weight polyadipate (Glyplast 206/X) (Figure 1) have been used in different quantities (5, 10, 15 and 20% wt).

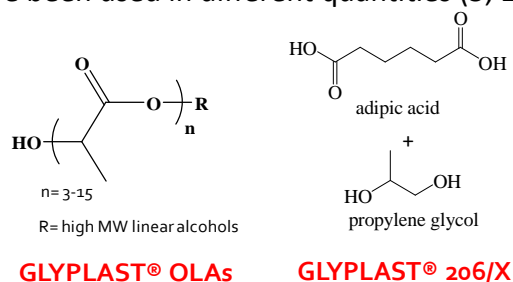

Figure 1: chemical structures of employed plasticizers provided by CQSA

A very large number of nanostructured fillers have been employed: cationic organoclay modified with different organic surfactants as coating on the inorganic surfaces of the nano-additives improving the interfacial interaction with polymer matrix; LDH modified with reactive plasticizer, layered Mg and/or Zn hydroxides (eventually organo-modified); graphene; nano-fibres (sepiolite-based) eventually organo-coated. As an example in Figure 2, they are reported some types of the organo-coated nanofillers.

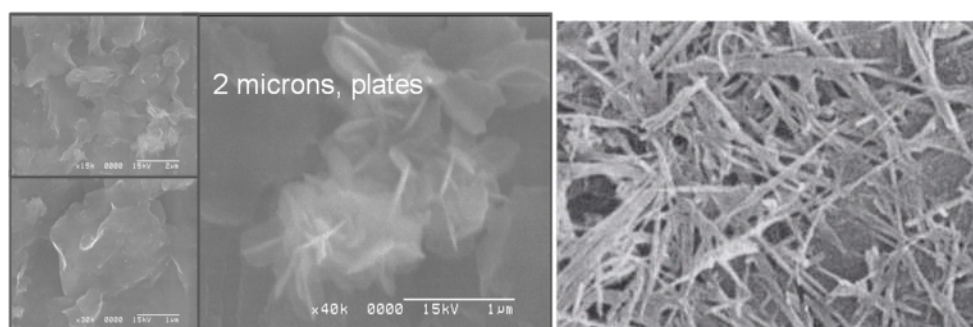

Figure 2: SEM images of organo-coated clay and fibre evidencing the different aspect ratios provided by AVANZARE

Poly(lactic acid) (PLA) has been selected as polymer matrix. Three different classes of bio-based materials have been defined and experimentally assessed by melt mixing the different selected components in a Brabender mixer, and then in a Haake Twin screw mini extruder.

- a) Plasticized and fully biodegradable materials.
- b) Reinforced and fully biodegradable materials.
- c) Flexible materials with functional properties (higher modulus and barrier features).

These last materials have been prepared by a two steps procedure by melt mixing in a Brabender mixer (Figure 3) that has been set by CNR, with the purpose to favour the dispersion of the filler by using the plasticizers even as surfactant. In addition a few runs have been also carried out by using Polybutyleneadipateterephthalate (PBAT) or PLA samples functionalized with OLAs-end functionalized as physical and/or reactive compatibilizers.

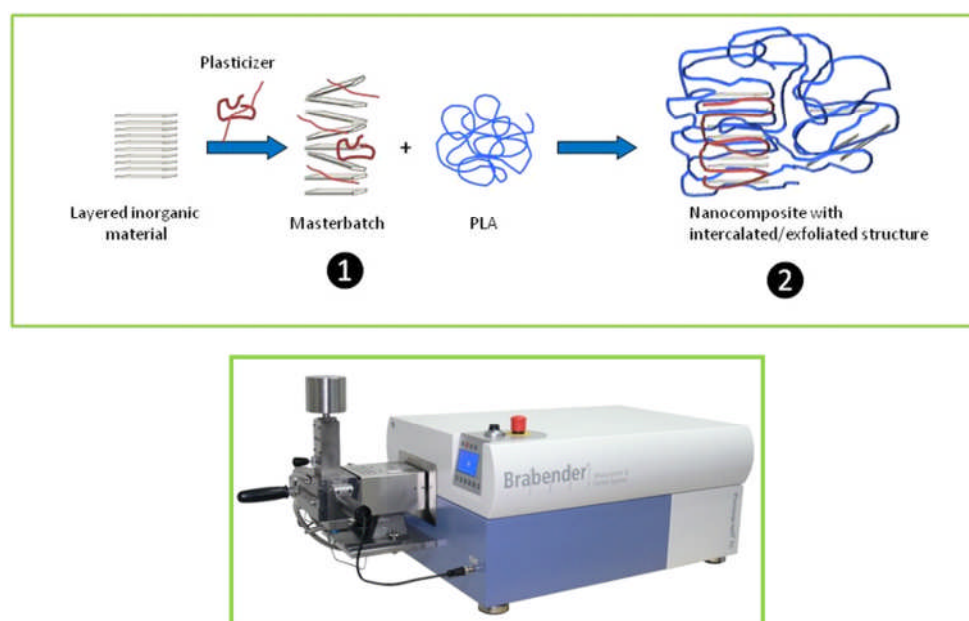

Figure 3. Two step procedure for the preparation of PLA/clay nanocomposites and machine used

Two different product series have been prepared and characterized:

1. plasticizer/nano fillers master-batches which were then dispersed in PLA (two steps process)
2. PLA/nano fillers (nano)composites.

The aim of the procedure was to optimize the two steps process by fine tuning both components and feed compositions on the basis of ultimate properties of the produced materials. The same formulations have been also processed by INSTM in the Haake mini lab twin extruder to produce dog bones specimen for mechanical and thermomechanical characterizations.

A fine and accurate characterization of all the plasticised blends and composites (Figure 4) in terms of thermal stability (TGA), molecular weight evolution owing to nanofiller embedding in the melt (SEC) thermal features (DSC), morphology (XRD, SEM, TEM), mechanical features, functional behaviour with respect to barrier effects (when possible) of selected/optimized products has allowed defining the best compositions to be used for the scaling-up phases.

By combining the results collected from the different techniques, the materials with targets assessed for classes a) b) and c) have been obtained with the following compositions.

- a) Glyplast 206/X resulted an effective plasticizer in all the different percentages tested, for example with a composition of 20% provided transparent and uniform films with elongation at break > 200% suitable for flexible packaging. In addition for this plasticizer, a good thermal

stability during processing in the melt has been observed and thus this plasticizer was selected for scale up production.

- b) Cationic clay organo modified, resulted well dispersed in the PLA matrix, even with low content of plasticizer, and presented an improved thermal stability for the PLA matrix. Sample prepared with 1% wt provided materials with Elastic Modulus 3.8 GPa (by tensile tests) and stress at break similar to that of the matrix 50-60 MPa (suitable for rigid jars)
- c) Different compositions resulted quite interesting: E was ranging from 1.1 to 1.7 GPa, stress at break was in the range 30-40 MPa and elongation reached 220 % by using 15% of Glyplast 206/X and cationic organo-modified clays or nano-fibres.

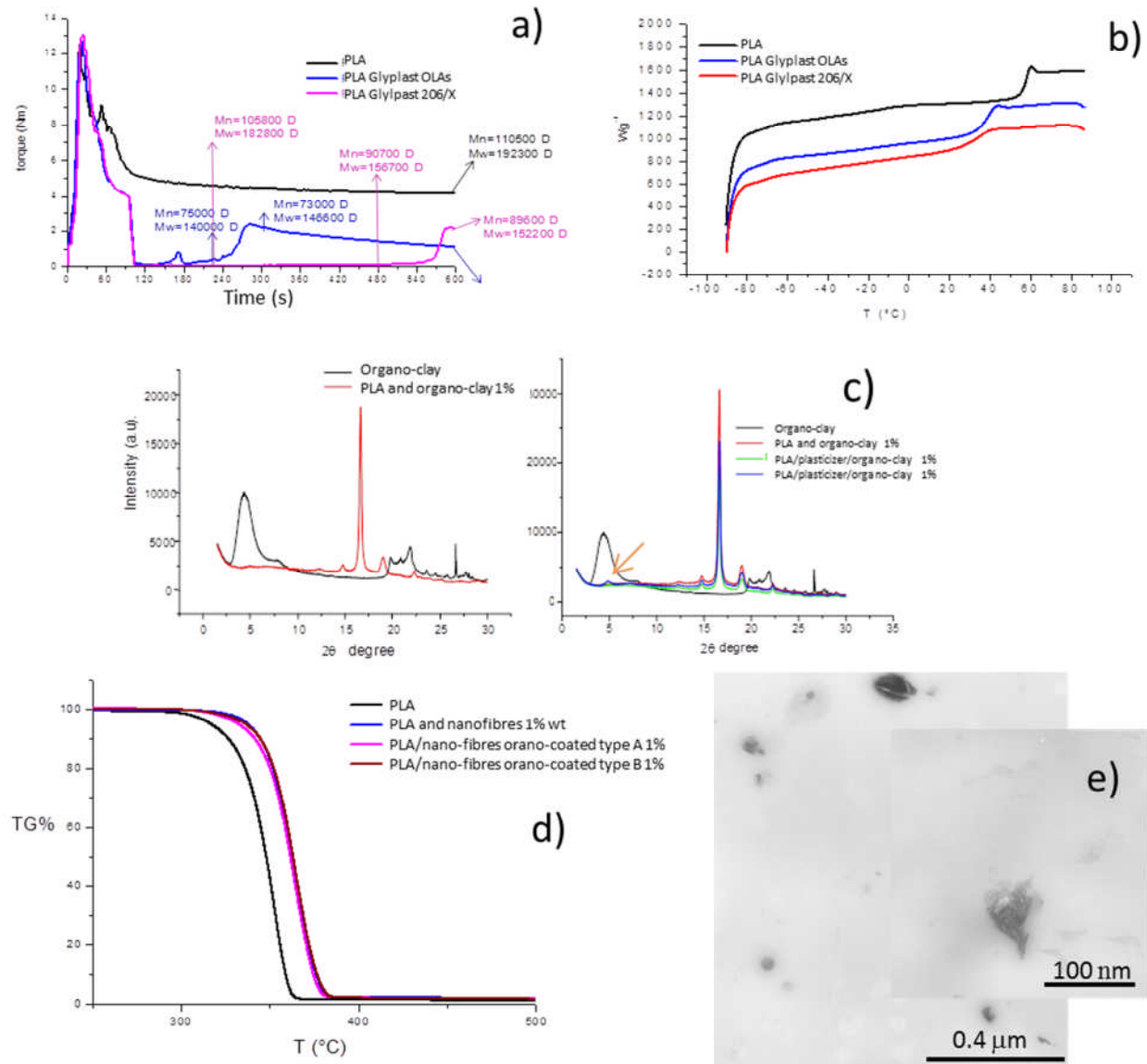

Figure 4: Examples of PLA-based composites testing: a) Torque and Mn/Mw evolution during the melt mixing of PLA with plasticizers of both families investigated; b) DSC analysis showing the exerted plasticizing effects; c) XRD paths of organoclay and different composites suggesting exfoliated or intercalated/exfoliated morphologies; d) TGA of composites obtained with fibres showing the improved thermal stability of collected materials; e) TEM images of nanocomposites obtained by dispersing LDH-modified by ionic exchange with a functional plasticizer (OLA family derived).

Molecular weight evolution suggested a good interaction without detriment of the structure, particularly when PBAT (1 or 3% by wt) has been added too. By using filler of the nano-fibre family (both with 1% wt and 3% wt) really nice films (Figure 5) were obtained with an improved thermal stability with respect to that of the matrix even in the presence of the plasticizer Tonset > 322°C and Tmax >366 °C while for the plasticized PLA the reference data were respectively 302 and 363°C.

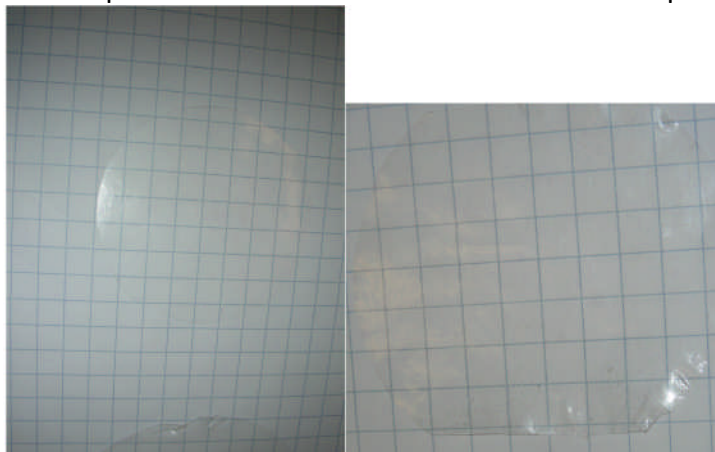

Figure 5. Films obtained by compression moulding of composites a) PLA/nanofibres 1%wt and b) PLA/plasticizer 15% wt/nanofibres 1%wt

Even if the prepared films at this step (by compression moulding) were not perfectly homogeneous and with the same thickness, preliminary barrier tests to Oxygen and Water were encouraging (-14 and -12 %) particularly for samples obtained using organo-clays.

Considering that for PLA the values of glass transition temperature (T_g) are around 60 °C there is the possibility that further crystallization may occur at temperature values above the T_g and this result in dimensional instability of the manufactured items under the operating conditions. Thus an extensive study has been carried out, addressing several types of nucleating agents and their effect combined with the presence of plasticizers. Design Of Experiment (DOE) method has been applied in order to use a systematic and reliable strategy of investigation. The final input of a DoE is to create a predictive model that can describe the relationships between the input variables and the final properties of the materials. This activity has been reported in a paper in press (M. K. Fehri, C. Mugoni, P. Cinelli, I. Anguillesi, M. B. Coltelli, S. Fiori, M. Montorsi, A. Lazzeri; Composition dependence of the synergistic effect of nucleating agent and plasticizer in poly(lactic acid): A Mixture Design study, Express Polymer Letter, Vol.10, 2016 in press.). Blends of PLLA (Naturework 2003D), plasticizers OLA8, and as nucleating agents PDLA (provided by CQSA) and LAK, that is an aromatic sulfonate derivative (Takemoto oil & fat Co Lt Japan), have been prepared on a MiniLab II HaakeRheomex CTW 5 conical twin-screw extruder (Thermo Scientific Haake GmbH, Karlsruhe, Germany) (Figure 6).



Figure 6. HAAKE™ MiniLab Twin Screw Extruder

Half time for crystallization, crystallinity and thermal properties have been recorded for several compositions outlining a synergistic effect between OLA8 as plasticizer and both PDLA and LAK as nucleating agents. Some interesting formulations have been selected meeting the requirements for respectively flexible and rigid packaging.

Table 1. Some formulation tested in the DoE selected as very promising.

Composition (%)	E_{Ten} (GPa)	σ_y (MPa)	ϵ_y (%)	EI (%)	σ_b (Mpa)	T_g (°C)	$t_{1/2}$ (sec)
(PLA 75 – OLA8 20 - LAK 5)	2.2	28	2	247	18	47	61
(PLA 82 – OLA8 13 - LAK 2.5 - PDLA 2.5)	2.6	38	2	11	27	53	46
(PLA 83– OLA8 7- LAK 5 - PDLA 5)	2.6	47	2	8.6	40	57	51

This study outlined that the use of nucleating agents can improve crystallinity when fast cooling below the T_g of PLA is applied for example in production of items by injection moulding. Otherwise it is recommended to injection mould the melted PLA based formulations keeping the mould temperature above the T_g of PLA, and for as long time as possible but still compatible with industrial requirements of production.

Both Glyplast 206/X and OLA8 resulted efficient as plasticizers for PLA based formulations, but since Glyplast 206/X presented an improved thermal stability on PLA during processing in the melt and was easier to handle for feeding on industrial scale extruder it has been selected for the scale up production.

They have been produced kilos of several batches of materials selected from the lab scale activity, by processing in Comac EBC 25HT pilot-scale co-rotating twin-screw extruder (Figure 7). Processing parameters have been optimised on eleven heating zones, speed of feeding (PLA main feeder, nanofibers on side feeder, plasticizer by liquid feeder), as well as flow rate, screws speed, power etc. The produced pellets have been shipped to industrial partners for evaluating the performance in terms of film production by biaxial orientation (Innovia), injection moulding (Tecos) and extrusion blow moulding (Aitiip).

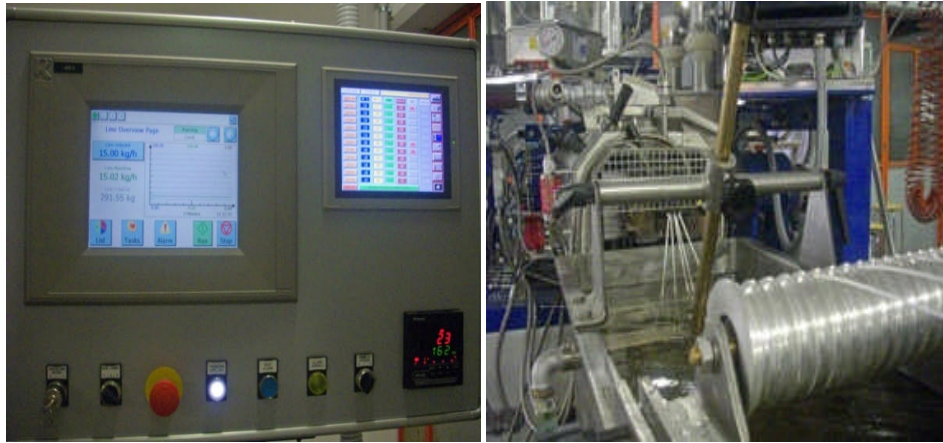

Figure 7. Image of the Comac EBC 25HT pilot-scale co-rotating twin-screw extruder, used for scale up production.

In formulation containing also the nano-additives, these resulted well dispersed in the polymeric matrix even when produced on the industrial scale extruder.

Feedback from industrial partners outlined that PLA2003D was not the best performing for film production by Innovia instead best results have been obtained with PLA Naturework 3001D, and thus this grade has been used for further activity for film production.

Feedback on extrusion and in injection moulding outlined that a plasticizer content of 10% by weight has to be preferred for this production, while for production of jars by injection blow moulding a 5% by weight of plasticizer has given the best results. For the production of jars even the addition of a strengthening agent such as Biostrength700, from Arkema resulted to improve processing. Even a product from CQSA (OLA2) has been tested for some formula proposed for the production of jars, and sheets.

Concerning the formula containing nano-additives the compositions with 3% by weight of inorganic nanofibres have been selected as the best performing matching processing, mechanical and barrier properties.

Some compositions based on PLA, Glyplast 206/X, nanofibers and respectively biostrength700 or OLA2 from CQSA, have been used even for the production of sheets by extrusion with a flat die. These sheets have been tested for the production of thermoformed packaging.

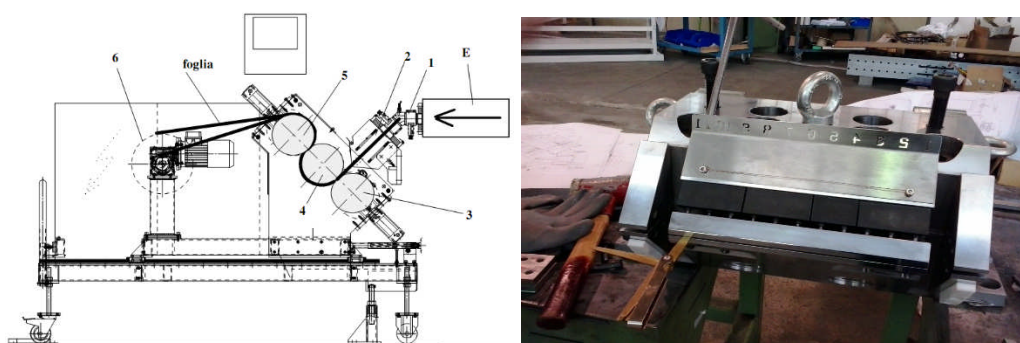

Figure 8. Flat die applied to the Comac extruder for sheets production.

WP2 - PROCESSES DEVELOPMENT, CHARACTERISATION AND OPTIMISATION

Critical processing parameters for injection moulding (IM), extrusion blow moulding (EBM) and Biaxially Orientated film extrusion technologies were identified, optimised and modified for variety of material formulations developed during the Dibbiopack project. Each of the chosen process technologies has been adapted to the products end-functionalities, including safety manufacturing proceedings, uniform dispersion and intercalation of nanoparticles, weight reduction, surface esthetics, and barrier characteristics.

To produce the optimized setting of moulding there are various tools and techniques for the processing optimization. An effective design of experiment (DOE) is the most powerful quality improvement technique to reduce the process variation, to enhance the process effectiveness and to define the process capability. The choice of DOE strategy depends a great deal on the degree of optimization required, resolution required, time and cost constraints, nature of the problem, etc. To evaluate the effects of inner control factors (processing parameters) and outer noise-factors on the shrinkage and flow ability of injection moulded products, statistical analysis based on Taguchi method was thoroughly investigated. Supported by the declared project results Taguchi design can serve as a reliable tool to determine an optimal parameter setting for the smallest shrinkage possible and longest melt flow. In parallel to the IM processing studies definitions a simplified design of experiment (DOE) was applied to minimize the defects in final extrusion blow moulded parts. To fully consider the processability behaviour of the Dibbio-materials and to define the optimal processing conditions especially for end-aesthetic packaging performances, FEM (Finite Element Method) simulations of filling and the pressure distribution through the flow path inside the newly constructed Dibbio testing moulds were further employed for accurate prediction of bionanocomposite's forming process by injection and extrusion blow moulding technology. Validation of the optimal parameters obtained through experimental injection and blow extrusion moulding trials was done by Moldflow® and Ansys Polyflow® benchmarking simulation results, respectively, and compiled into a technological window, presenting a practical guide for the processability recommendations on Dibbio-materials. For injection moulding process the most critical factors identified were cooling and drying time for the processed materials. The material should be pre-dried for at least 2 hours (preferably 4 h) at 70-80 °C. The temperature of the mould should be as low as possible, preferably around 15 °C. The melt temperature was found to be an important variable that can impart the stability of the injected parts. From the trial results it is advisable to decrease the temperature processing for biomaterials to 170-180 °C so to avoid the sink mark deformations on the final products. If the process parameters are not adjusted properly the produced moulded parts can be affected by streaks, hazing, blistering, warpage and jetting defects. Reminding that the temperatures are the most critical process parameter affecting the extrusion blow moulding process of biopolymers, this can be very important, so the kinematic (slow) of these values should be considered. The feeding section of the EBM machine should be well cooled on the other hand, because if the feeding rate is low, the pellets that stay in the hopper more than 10 min without entering in the screw, start forming clumps and block the material feeding. The residence time of the plastic melt in the screw or the accumulator should be reduced as much as possible, because the thermal degradation of the PLA is faster than in commodities.

Aiming at improved exfoliation and uniform dispersion of nanoclay particles over the biopolimeric matrix, hence increasing the barrier and mechanical characteristics of the sustainable packaging products, adaptation of the supercritical fluids (SCF) technologies (N₂ and CO₂) for injection moulding process was studied in detail. Different nanomaterials in various content ratios (1, 2, and

5 wt. %) were used for the preparation of the batch material, which was later foamed by SCF (CO₂) - Mucell technology. For the evaluation of the nanoparticle dispersion Scanning Electron Microscopy (SEM) was used to verify the morphological properties of the resulting composites and flexural/tensile tests for the mechanical behaviour of each probe on every different composition. Morphological results proved that nanoadditives of the particular platelets formation can be dispersed uniformly, but their mechanical characteristics decreased (brittleness) when comparing the flexural and tensile performances of the base reference material. In case of nanofibers incorporation, higher tendency toward agglomeration was observed in particular nearby the foam cells. Despite the aggregates nanocomposites holds good mechanical performances, remaining quite homogeneous without a strong dependency of the flow orientation, in particular high elongation at break when working under high flexural loads. Nevertheless, ultrasonication technique is suggested prior the injection process so as to disaggregate the agglomerates formed and achieve a better dispersion.

The primary ambition of introducing the MuCell technology is the weight reduction of the plastic components and is accepted globally as a technology option for providing a more dimensionally stable part through a reduction in residual stress, along with increased productivity versus solid injection moulded parts. With supercritical fluid (N₂) assisted injection moulding technology we managed to obtain for about 20% lighter materials with relatively high mechanical characteristics. Trials included the adjustment the processing parameters (injection speed, melting temperature, cooling time) and nitrogen percentages (trials conducted with 5, 10 and 15 % of N₂ injection) to evaluate the best outcome solutions on Dibbio material formulations. By experimental testing performance and measuring the reduction in weight it can be concluded that the maximum of 15% of N₂ can be realized directly to the melt. With varying other parameters, some improvement on mechanical characteristics of the final parts can be achieved, but in total the percentage of N₂ injection has by far the greatest influence on the end packaging performances. By comparing the base and Mucell moulded samples, the elastic modulus (E_t) and elongation at break (ϵ_b) of latter represented higher values, meaning more stiffer and more elastic materials can be formed by SCF processing. However tensile strength (σ_M) for Mucell samples decreased for about 14 MPa when compared with σ_M values for non-foamed samples.

After the establishment of technological frames for injection and extrusion blow moulding processing of the developed Dibbio materials for food trays, cosmetic jars and pharma bottles, it was necessary to adapt the extrusion laminating technology to develop and characterize films that aims to be utilized as closures or lidding films/labels in previous packages. Through the technological advancements in the context of Dibbio project activities it was demonstrated that Biaxially orientated PLA films can be produced on both a lab scale and a pilot scale with key scale up parameters to industrial scale defined. The majority of customers value plastic labels and lidding materials that are highly transparent with high gloss finish as this maximises on-shelf appeal of the product and this has therefore become a key target for this PLA film from the project point of view. Films produced using both laboratory (requires approximately 10 kg of material) and pilot line (requires approximately 300 kg+ of material) methods were relatively heat stable with good optical and low shrink properties. The films properties generated by production on Pilot “Stenter” machine allow for its use in the standard label, packaging and lidding market applications. The produced films passed the EN13432 biodegradation test (European norms), whereas samples containing the nano-additives are expected to give better barriers than the standard film. Unfortunately the attempts at adding the nanoparticles, crystallisation accelerants and plasticisers to the base PLA

resulted in failure in all cases. Nanoparticles were not fully dispersed and thus the agglomerates caused cavitations and problems, even in areas where they were well dispersed they caused a major reduction in material optical properties and thus minimised possible use. Crystallisation accelerants may work in a cast film, but do not work in a biaxially oriented process where control of crystal content and generation rate/time is critical. Plasticisers tried on the whole did not disperse well and appeared to agglomerate in a drawn film, thus causing problems with film appearance. Even when well dispersed at low loadings little change occurred in the final film properties. With respect to such conclusions it appears to be unwise to add any of the mentioned additives to the film especially if the material is planned to be used as a lidding material. If the material is to be used as a label for a container it could be pigmented and / or remain clear depending upon packaging materials and properties desired. If it is pigmented addition of nanomaterials could be made although this would decrease the material process-ability, whilst not generating any significant advantages as seen from the resulting film properties. The effect of film orientation on material characteristics seems to have greater effect on material properties such as stiffness and clarity and thus unless large effects on the barrier of the materials is seen the material will probably be better produced as a pure biaxially oriented film with good optical and tensile properties.

The film materials developed were further combined with hybrid polymers, called ORMOCER[®]s, (registered trademark of Fraunhofer Gesellschaft zur Förderung der angewandten Forschung e.V., Munich) and Plasma technology pursuing the radical improvement of its barrier capacity. In the fields of food, cosmetic and pharmaceutical applications, there is a growing demand for functional polymeric materials with enhanced barrier properties against water vapour, oxygen, aromas etc. In general these barrier requirements involve the combination of inorganic and hybride multilayers. The realisation of these demands becomes even more sophisticated, if an additional property such as biodegradability has to be met. Within the Dibbiopack project it was attempted to develop a novel barrier concept for DIBBIO film substrates by combining the inorganic plasma coatings and the newly developed material class of bioORMOCER[®]s. To integrate biodegradability in hybrid polymer systems, modified biopolymers were incorporated into the network allowing strong chemical bonding to the basic ORMOCER[®]. The modification of the biopolymers was necessary to transform the hydrophobic surface and to improve its dispersibility with the basic precursors as well as the formation of strong covalent bonds between the different precursors during either sol-gel reaction or the final organic curing of the coatings, respectively. The resulting bioORMOCER[®] coating with a film thickness of approx. 1-3 μm exhibited good optical transparency and homogeneity, showed first signs of biodegradation in compost tests after 3-6 weeks and comparable barrier properties compared to the state-of-the-art barrier of non-biodegradable ORMOCER[®] coatings. To adapt the coating application to the thermal stability of the PLA films, the curing conditions of the bioORMOCER[®] lacquer was optimized to approx. 30 min at 100 °C but could be reduced to 80 °C as well if needed. This novel bioORMOCER[®] composition was incorporated by combinational approach of the final sandwich set-up of sputtered inorganic coatings and bioORMOCER[®]. The first layer of bioORMOCER[®] here acts as a planarization and adhesion promotion layer, as the inorganic coating could not be processed on pure PLA due to different mismatches for example in the CTE (thermal expansion coefficient). The inorganic multilayered based coating is performed in PVD chamber by magnetron sputtering in different O₂ or N₂ gas atmosphere. A process steps for this multilayer application involves plasma etching/activation of films in O₂ atmosphere, then following the depositions of Si in a gas atmosphere with O₂ and N₂ in PVD chamber; a layer thickness from 10 to 100 nm per deposited layer depending on conditions of depositions (applied current density, time of deposition). The final

coating involves bioORMOCER® lacquer which acts as the final barrier coating with synergistic effects of the two materials.

The film materials obtained have a dual use, as lidding films for the closures of injection moulded packages developed in the project, and as labels to be attached to these packages through In Mould Labelling (IML) technology by injection moulding and extrusion blow moulding process. IML technology consists in decorating bottles, containers and other plastic parts directly in the forming mould (blow or injection moulding). In mould labelling provides an excellent alternative to traditional methods of labelling, since it offers many benefits in terms of production time and cost savings as well as aesthetics of the products. In mould labelling (IML) however requires a proper mould design and construction for accurate label placement and reliability of the IML process technology. Besides the injection or blow moulding machine, process parameters and the type of the labels used, the quality of injected IML parts is significantly affected by the mould design, which must be deliberately considered and carefully constructed. Conceivably the most complex feature of IML technology is the way the label is held in place in the moulding tool and the gate location, which is critical because the material has to enter and flow into the cavity and approach the label in a specific way to achieve the quality required. The objective of the project was to provide an insight into the accurate design and precise construction of moulds for IML processing technologies. The testing injection and blow moulds were equipped with vacuum ports for holding the label and completely re-designed for optimised IML processing of biodegradable materials. For IML injection moulding process the use of very precise processing parameters is the most important issue once we have correctly adjusted the IML hardware. According to the project results the best performance on final products were obtained by labels with well distributed calcium carbonate in term of efficient and optimal labelling placement. Also the best adhesion with the base material is achieved with these types of labels. In order to limit the label displacement the most important IML parameter was found to be injection velocity, which needs to be around 30 mm/s, and the label thickness for which required thinness would be between 20 to 30 µm. In the case of IML extrusion blow moulding, the adhesion between label and package material is more critical due to the lower temperatures, but with a tempered mould, and using PLA labels coated to improve this adhesion, the results obtained were very satisfactory.

WP3 - SMART DEVICES DEVELOPMENT FOR MULTIFUNCTIONAL PACKAGING CONCEPTS

The first action on this WP were focused to first, the selection of materials for antimicrobial coatings by testing different combinations of state-of-the-art antimicrobial ORMOCER® lacquers and antimicrobial nanoparticles on DIBBIOPACK biodegradable substrate films. The aim was to identify promising combinations with high antimicrobial activity which will be compared with the newly developed biodegradable antimicrobial functional coatings later in the project.

The development of functional antimicrobial hybrid coatings (ORMOCER®s) within this project is the main expertise of Fraunhofer ISC. The aim is to transfer the knowledge of antimicrobial hybrid coatings, which can additionally contain antimicrobial additives, onto newly developed biodegradable coating materials. Meanwhile, the antimicrobial nanoparticles were prepared by AVANZARE who have experience in the preparation and characterization of numerous antimicrobial nanoparticles. With the combination of these two material concepts, i.e. functional antimicrobial hybrid coatings from ISC and antimicrobial nanoparticles from AVANZARE, new materials with high antimicrobial activity were expected.

For the evaluation of the ORMOCER®-based antimicrobial coating materials, the hybrid coating materials were mixed by ISC with varying portions of different nanoparticles sent by AVANZARE. The resulting lacquers

were then applied onto A4-sized sheets of the biodegradable substrates and a number of different tests were performed.

In the case of the antibacterial activity tests, these were carried out by ARCHA in accordance with the established standard ISO22196:2007, where the tests were performed on two bacterial species: *Escherichia coli* and *Staphylococcus aureus*. However, after increasing the inoculum concentration and thus adapting the method procedure, two promising formulations were identified. During Month 13 and Month 14 these two promising formulations were tested once again by ARCHA in order to validate these earlier results. It was noted that humidity conditioning reduced the antimicrobial activity only on ANDIB 73_2 0.5%. Therefore, according to these results, ANDIB 92 0.1% was confirmed to be a suitable candidate.

Then, the second step was to prepare a biodegradable and humidity activated antimicrobial coating ORMOCER lacquer.

This task commenced at the beginning of Month 6 with a literature study being performed by ISC over the following months to identify suitable materials in order to modify the ORMOCER[®] lacquer systems with regard to biodegradability.

Following this literature review, ISC noted that there are some interesting approaches for the development of a humidity-triggered release of antimicrobial additives/particles. Nevertheless, the release activity of the matrix relates to a particular ORMOCER and ISC believe that it is not trivial to transfer this property between different ORMOCER's, that is the state-of-the-art ORMOCER at the moment and the newly developed biodegradable ORMOCER within the process of this project. So what ISC planned was that they will firstly develop the biodegradable matrix itself before they will modify this matrix concerning the humidity activated release mechanism.

For developing a biodegradable ORMOCER[®] material two different concepts were designed at ISC: Class I type hybrid material (physical mixing of biopolymer particles into the ORMOCER[®]) and Class II type hybrid material (covalently bonded biodegradable moieties within the ORMOCER[®]). For this second type ISC needed to functionalize the biopolymers with coupling groups, which can react with the ORMOCER[®] or the ORMOCER[®] precursor.

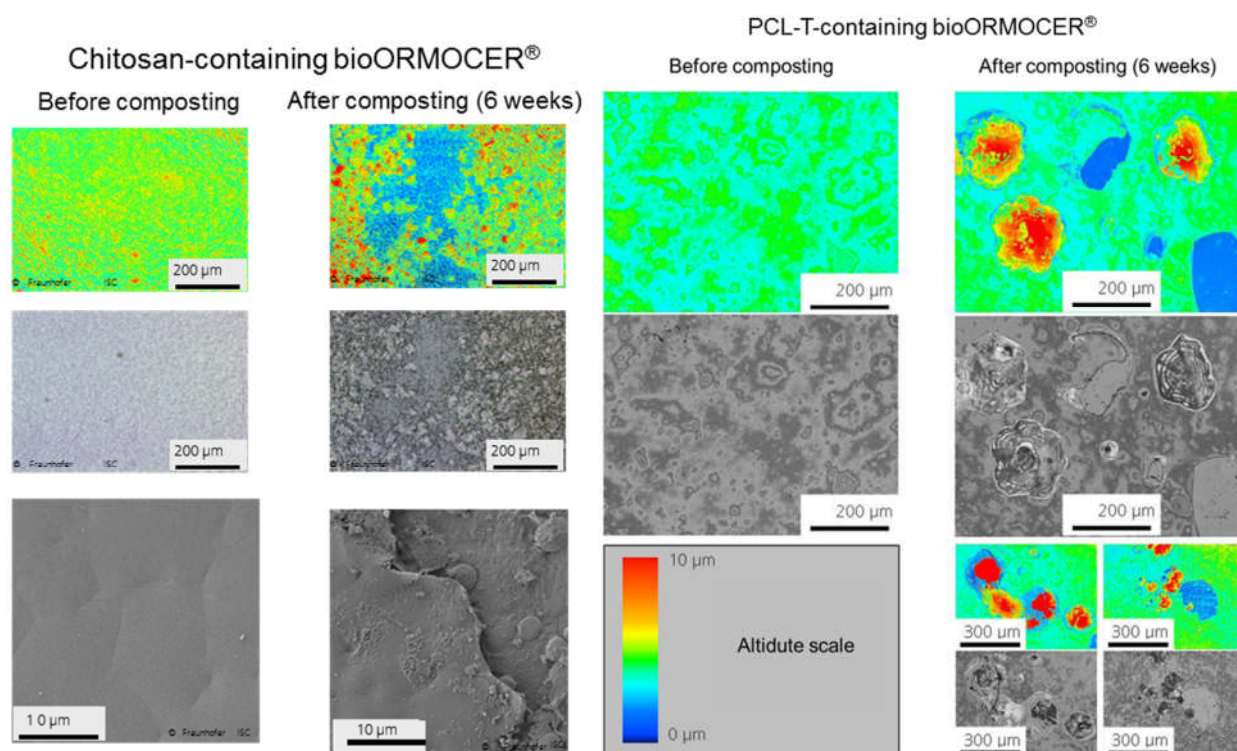

Based the Evaluation of most promising combination of antimicrobial additives by AVANZARE and state-of-the-art ORMOCER® antimicrobial active coatings were prepared by ISC by combining the newly developed biodegradable bioORMOCER® coatings and the antimicrobial additives.

These antimicrobial tests show, that the biodegradable bioORMOCER® coatings with the biopolymer chitosan only show high activity, if the samples are fresh. If stored, they do not show significant activity independent of the additive. On the contrast, the PCL-T containing coatings exhibit significant increase in antimicrobial activity upon humid storage, if filled with nanoparticles ANDIB73_2 (they show almost no activity with the nanoparticles ANDIB92). Thus, in summary we found systems with high activity in the beginning and a humidity triggered antimicrobial active coating system, as well.

A standard ISO biodegradation test ISO (14885-1:2005) was furthermore run at ARCHA to evaluate the biodegradability of biodegradable substrates coated with the most promising combinations of these biodegradable coatings and antimicrobial active additives.

All samples passed the threshold limit imposed by the standard ISO 14885-1:2005, because the percentage of biodegradability reached over 90% before six months. The ORMOCER® coated samples have reached the biodegradability percentage higher than 90% in about 130 days of testing. In terms of biodegradability behaviour of pure ORMOCER® samples, we can assess that the two different ORMOCER® coatings with antimicrobial additives have shown comparable results in terms of biodegradability. The rate of biodegradability is only slightly lower than the biodegradability of the pure ORMOCER® sample. This result is attributed to the antimicrobial effect of the additives, which might, as well, affect the compost.

In summary, in this task elaborative work was performed to develop biodegradable bioORMOCER® coatings. The biodegradability was demonstrated in basic compost pre-tests and with standard tests, respectively. Furthermore, the antimicrobial additives, as synthesized by AVANZARE (or molecular active materials) and evaluated in D3.1.1 for state-of-the-art ORMOCER®s, were combined with these newly developed biodegradable coating materials and promising antimicrobial active coatings were prepared.

Influence of layer concept on antimicrobial release

Next to the different bioORMOCER® compositions, the effect of a final layer of bioORMOCER® was investigated. This final layer was not filled with antimicrobial additives. Its influence on the antimicrobial release was evaluated. In the following figure the additional layer concept is depicted.

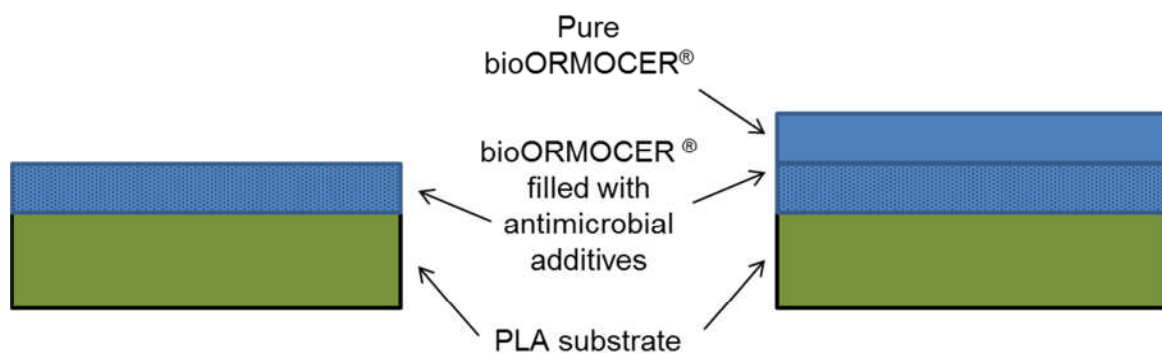

To compare the antimicrobial release, the following figure summarizes the amounts of Zn^{2+} for the two systems in dependence of rinsing steps.

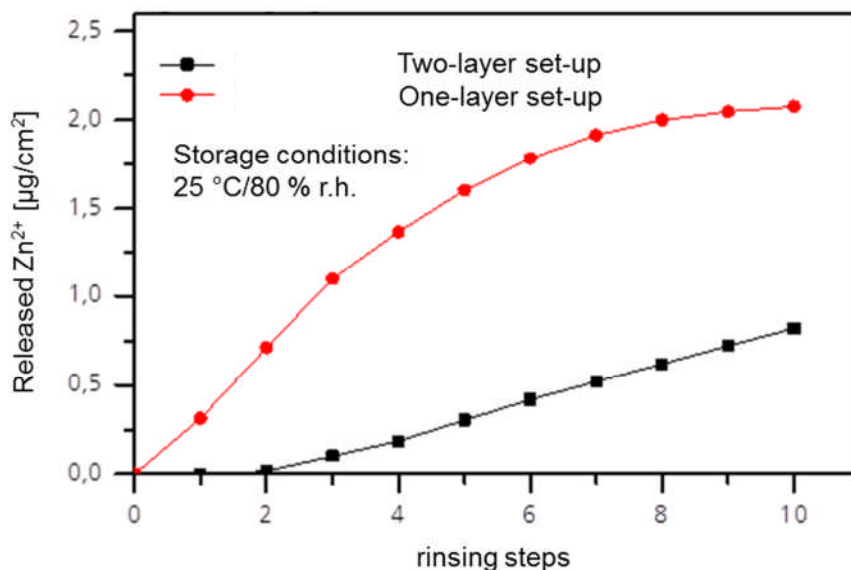

In contrast to the one-layer coatings, the release of antimicrobials is significantly retarded in the case of the two-layer coatings. It takes two rinsing steps (48 hours) until the antimicrobials have migrated to the surface.

This retard effect is attributed to the increased path, which the antimicrobials have to pass, until they reach the coating surface and can be rinsed off.

However, the dominating difference in the release behaviour compared to the one-layer setup is that, after the release started, the liberation of Zn^{2+} remains constant and does not change during the time of storage. Thus, this coating system represents a totally different kind of release system. Whereas the one-layer coating represents a monolithic solution (in this case, release is dependent on the amount of the additive that is contained within the matrix), the two-layer coating acts as a reservoir system (i.e. the released amounts are independent of the remaining concentration within the matrix).

Thus, we successfully demonstrated the development of two different types of humidity triggered release systems based on the biodegradable bioORMOCER® coatings, filled with ANDIB73_2 (by AVANZARE)

Another goal of this WP was to examine the options available to combine the state-of-the-art Oxygen (O_2) indicator developed by Fraunhofer ISC with a wireless reading (sensor) system. The design of this prototype sensor system would consider the requirements of the projects manufacturing partners (end-users) from the Cosmetic, Food and Pharmaceutical industries respectively, details of which are set out in the specifications document at the beginning of the project.

Since one of the objectives of the project requires us to incorporate the state-of-the-art oxygen indicator of Fraunhofer ISC into a small label which can be integrated into packaging at a later stage, and since the ISC indicator works on the principle of a colour change from colourless to blue when the level of oxygen exceeds 2%, GTI proposed and developed a solution that uses a wireless optical system to detect this colour change.

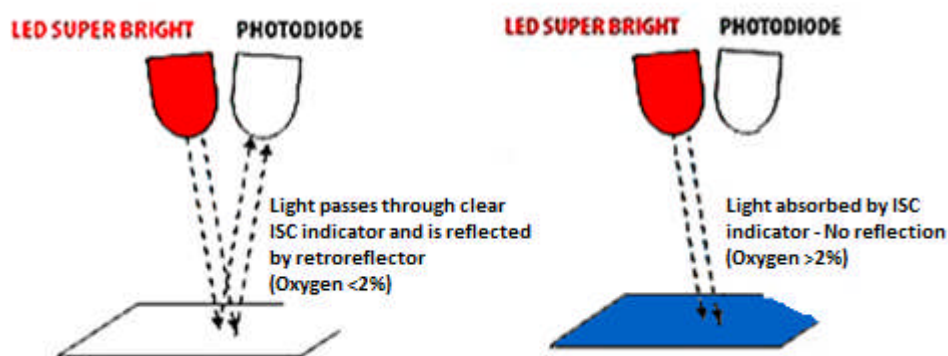

Principle of operation for the Optical Sensor

The concept uses a reflective surface placed behind the ISC indicator, which will ultimately be incorporated in the product label and/or RFID tag inside the food package. By shining a bright LED light from outside the package towards the ISC indicator it was observed that, when O_2 levels are below 2%, the indicator is sufficiently transparent to allow light to be reflected back and detected by a photodiode, thereby indicating the absence of unwanted concentrations of oxygen. Conversely, it was further observed that if O_2 levels are above 2%, and therefore the ISC indicator changes to a blue colour, then the light is absorbed (not reflected) indicating the presence of undesirable levels of O_2 .

During the time period in question GTI built a number of different prototype designs for test purposes and, following a number of minor improvements and modifications to overcome the problem of directionality, it was then possible for GTI to build a more complete and robust prototype optical sensor system and finalise the design.

Regarding the RFID tag development, GTI had to first decide which RFID frequency would best serve the requirements of the project. In relation to this project, there were two main RFID frequencies available for consideration for this type of system, namely High Frequency (HF) and Ultra High Frequency (UHF). This classification is based upon the radio frequency (RF) at which the technology operates; HF is at 13.56 MHz, while UHF is at 860-950 MHz.

While UHF RFID has been embraced for longer-range supply chain applications and have a slight edge in terms of cost, HF frequency provides resistance to common sources of interference found in commercial and industrial environments, which has been a considerable problem for UHF systems in recent years. For these reasons, GTI selected HF as the chosen frequency for this project. More specifically, similar to an RFID enabled Smartphone, GTI opted for HF Near Field Communication (NFC) RFID protocols, of which there are 3 ISO international standards; namely ISO15693, ISO14443A and ISO14443B. In order to allow for the greatest flexibility in terms of the particular NFC tag used throughout the project and subsequent tests and trials, the reader to be developed in Task 3.2.3 will have the capability to read all 3 of these HF/NFC standards.

In addition to the NFC component of the tag, and since one of the objectives of the project requires is to incorporate the state-of-the-art oxygen indicator of Fraunhofer ISC into a small label which can be integrated into packaging at a later stage, the next item GTI had to consider was how the ISC indicator might be integrated with the tag design.

Task 3.2.1 (above) outlined an issue identified with the directionality of the LED and photodiode on some early prototypes of the optical sensor. In order to overcome this particular problem GTI proposed the use of a 'retroreflective' sensor in which light would be split between reflected and transmitted light. However, for this approach to be successful, it would also require the integration of a retroreflective surface on the tag.

Following a number of internal tests using the prototype circuit described earlier, GTI determined that a corner cube retroreflector would best suit the needs for this particular project. Due to this simple construction, thousands of these cube shapes can be moulded into a rugged plastic reflector or vinyl tape material and are suitable for use with both standard reflex and polarized reflex sensors.

Therefore, since one of the objectives of the project requires us to incorporate the state-of-the-art oxygen indicator of Fraunhofer ISC into a small label which can be integrated into packaging at a later stage, and considering the issues and points highlighted above, the final design of the RFID Tag will consist of the following elements;

- i. An NFC (HF) RFID tag, consisting of a circular (coiled) antenna design and microchip, on a white PET carrier substrate material, which has the centre material die-cut and removed. Alternatively, the NFC antenna component may also be on a clear (transparent) PET carrier, although the preference is to use the first option where possible. In either case, the NFC component can be either the ISO15693, ISO14443A or ISO14443B NFC RFID protocol.
- ii. The ISC oxygen indicator dye will be incorporated onto a small area of a separate PET carrier substrate. This will be achieved by printing the ISC dye in a circular pattern, approximately 15mm-20mm in diameter, and which to be centred in the middle of the NFC antenna.

- iii. A small, circular area of retroreflective tape, to be positioned directly behind the ISC indicator layer, and also having a diameter of approximately 15mm-20mm.
- iv. A PET spacer, placed between the NFC and the ISC indicator, which is required to allow the oxygen within the package to be detected by the indicator in the first instance.



RFID Tag before (L) and after (R) exposure to Oxygen)

The RFID Reader module to be developed in this WP completes the third part of the overall Oxygen sensor. Its purpose is to interrogate the NFC RFID tag to determine if the tag, and therefore the ISC indicator, is present in the first instance. If a valid NFC tag is present, then RFID Reader will trigger a signal from the GTI module to turn on the red LED and measure the reflected signal (if present).

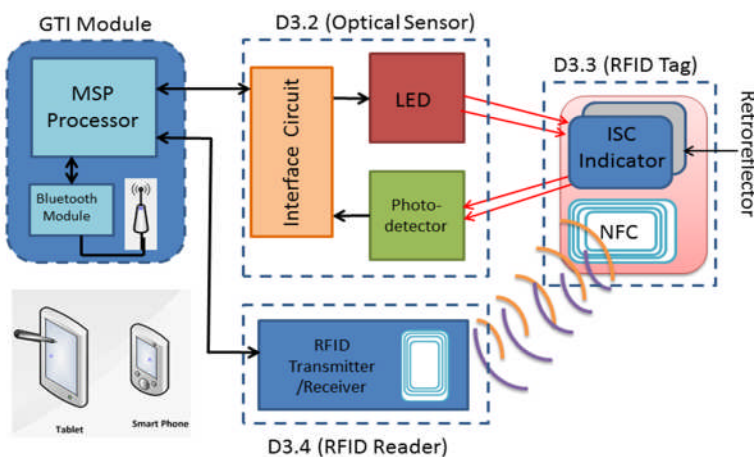

Complete System - Block Diagram

In considering the design of the reader, GTI investigated the current state of the art to determine if a suitably appropriate module or development kit existed that could be used in the application at hand.

While a small number of options were available on the market, one of the main deciding factors would be the size and cost, as well as their ability to support the features required. For these reasons, GTI researchers determined that the Texas instruments TRF7970A EVM NFC RFID module, which includes an MSP processor, a HF reader and a TTL/USB adapter chip, would provide a solid base from which to develop the required RFID reader. In addition, the availability of appropriate firmware to allow the development of software for demonstration on a PC desktop would greatly reduce the cost and speed up the development.

In addition to the TRF7970A EVM module, GTI also identified the TI EZ430-RF256X Bluetooth module which would be integrated with the TRF7970A EVM to allow wireless communication with a smartphone or tablet

computer, before constructing the final prototype in a small, hand held module comprising both the ISC oxygen indicator probe and the HF RFID NFC module.



Circuit boards & Housing

Initial tests were performed to analyse the suitability of the colour change of the Fraunhofer ISC oxygen indicator with the RFID unit, developed by NUIG. After passing these general tests it was discussed how to integrate the indicator system within the Dibbiopack packaging systems.

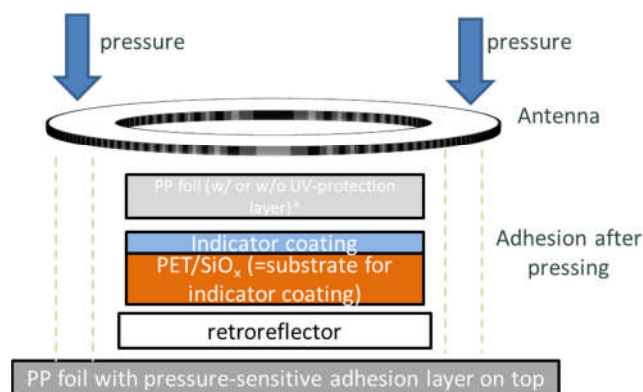

In this setup, the indicator coating is applied onto a PET/SiO_x substrate. The retroreflector substrate, which is needed for the RFID unit, is added behind the PET/SiO_x substrate. The indicator layer, which must face the product, is then protected from mechanical and humid abrasion by covering it with an additional polymer substrate. The basic indicator principle is based on the reversible activation of the indicator dye. Due to this reversibility, the coloured indicator layer (after contact with oxygen) must remain coloured, i.e. it must not be reactivated by accident. Thus, two different set-up modifications were developed to investigate the role of the covering polymer.

The first modification is the covering with pure PP (polypropylene) foil. This PP foil is very permeable against oxygen and thus does not falsify the detection of oxygen by the indicator. The second modification is the covering with PP foil, which had been coated with a UV protection coating beforehand.

Thus, it can be evaluated if:

- The colour change is still detectable for the RFID unit when the indicator layer is covered with (UV-protected) PP foil
- Reactivation is still possible (especially due to the UV-protection coating; The coating has to be transparent for the activation wavelength and intensity)
- The coloured indicator is long-term stable due to the UV protection coating.

On top of the covering foil, the antenna (connection with the RFID unit) is placed. To fix the whole set-up, this antenna is linked to a basic substrate at the back of the set-up. This basic substrate (PP foil) is equipped with a pressure-sensitive adhesive coating and thus prevents the individual components from slipping.

Furthermore, the partners then discussed where would be the optimum position to integrate the indicator sensor system within the packaging set-up. In the following figure the proposed integration into the packaging is displayed (see the following scheme).

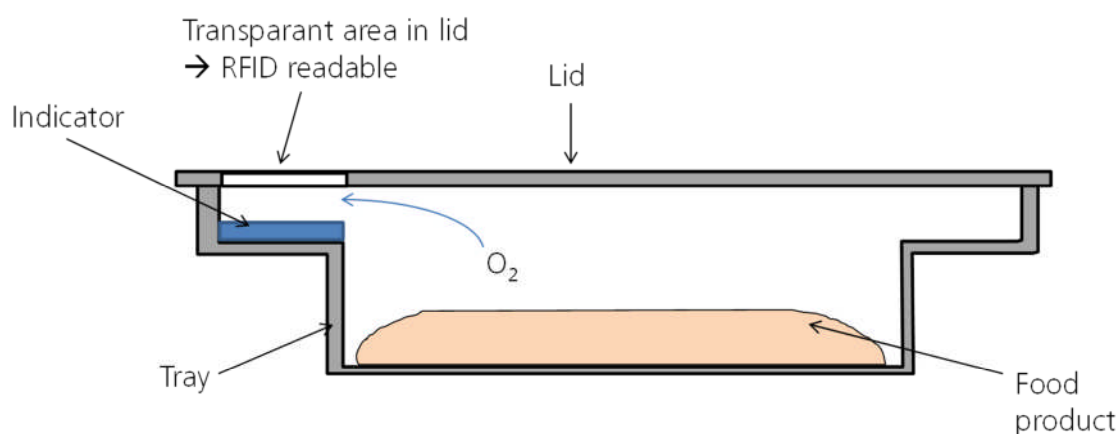

To avoid contact with food, and to allow the RFID reader system to picture the reflector foil, an elevated position of the indicator system is proposed.

Summarizing: At first the general properties of the oxygen indicator were evaluated to summarize the requirements that will have to be met for successful integration within the DIBBIOPACK materials and processes. This analysis showed that the humid and mechanical abrasion of the indicator layer from the substrate during preparation and handling, as well as the stable storage (due to light and heat sources) would need to be considered. Furthermore, it was investigated how to activate and read the colour change of the indicator upon contact with oxygen with the equipment of the RFID system.

With the selection of both the appropriate NFC reader and Bluetooth modules complete, and their subsequent integration in to the prototype GTI module, efforts could then be turned to the design of the associated software. In order to understand the general operation of the proposed system, a control flow diagram of the initial software module was completed by GTI.

The program starts with turning on the optical probe light at low power to allow the user to direct the modules probe light on top of the ISC indicator area. If the module is not in sleep or rest mode, the HF RFID reader will then read the package tag ID and any other relevant information stored on the RFID tag developed in Task 3.2.2. If the tag ID captured by the RFID reader is valid, the optical probe light is turned on to full power to probe the ISC oxygen indicator's status before being then turned back down to low power again in order to save battery lifetime. Based on the measured status of the ISC indicator, the optical sensor

module will then report back the result specific to the package to a PC or Smartphone, via the Bluetooth 2.1 wireless communication module, where the data can then be stored in the database, while the Oxygen status including time, date and package location will be programmed back on to the package RFID tag by the RFID reader. The process then repeats as shown until the module is either turned off or reset. To assist the user in identifying at risk products, an audible indicator is also provided by means of an in-built buzzer which provides a short audio alert when the level of oxygen in the food package is above the 2% concentration limit.

Based on feedback received from the relevant partners following the demonstration of the prototype Wireless sensor system at the M18 review meeting in Dublin, it was agreed that the control flow diagram, which was partially implemented as firmware in the prototype model, required further work before the work on the application development could proceed in earnest. In particular, consideration was given to the way in which information would be stored in the database, as well as the way that information such as the time, date and the oxygen status would be written to the RFID tag.

In order to achieve this, GTI first performed a general review to further test and debug the GTI developed module software, including the RFID module and the Bluetooth module firmware. Indeed, this software testing and debugging review will be a continuous, reiterative process throughout the remainder of this task, as GTI seeks to interface the module to one, or more, databases residing on a local computer server initially (for test purposes) before ultimately linking the module and the data generated to a cloud-based database

With the new control flow diagram in place, GTI then spent some time revisiting the various pieces of software already completed for the GTI Handheld Module and the Bluetooth Module Firmware, in order to try and extend the battery life of the GTI hand held module reader. Through this software debugging process, and by turning off all unnecessary functionality, shortening the LED on times and putting the module into the lowest possible Standby Power Mode when the GTI Handheld module is not being used, GTI were able to extend the battery life of the Handheld Module up to approximately 1.5 days.

Therefore, the GTI module now goes into Standby mode in the following situations:

- When the GTI module is first turned on, by pressing the ON/OFF Button.
- When the Bluetooth connection between the GTI Module and the Android Smartphone is broken or lost.

With the control flow diagram now complete, GTI then progressed on to researching and developing the database considerations in order to find out what was required for a customer/person to access the database on the phone, what types of data should be stored on the database, who could access the database and how they might achieve this, as well as determining when or where in the process this may be done. With this information, GTI began the work of designing and implementing an Android “Data Logger” App which provides the means for connecting and storing the GTI data upload onto a database on the Cloud. Initially, GTI concentrated on both the User Interface of the App as well as the means by which the App will connect (via the network) to the appropriate server(s) in the cloud. In preparation for this, GTI acquired space on an online server to implement the database, with enough storage capacity to store the data uploaded from the GTI Module.

Following this, GTI, and more recently NUIG, continued to work on the development of the systems’ software application (App), which will be used to upload data from the reader into the database hosted on a remote server in the Cloud. To date, the developed Android App is capable of receiving, displaying and storing data from individual tags scanned by the reader.



More specifically, it receives and stores data related to the time and date a particular tag was scanned (referred to as the “Time & Date Stamp”), as well as the RFID tag’s unique identification number (Tag UID) and the Oxygen status of the package under test (i.e. whether the product has PASSED, FAILED or needs to be ReScanned).

The Android App consists of two tabs. The first is the “TEST” tab which is the main window used for tracking and testing the Oxygen status of the product under test. The next figure, shows the graphical User Interface (GUI) displayed under the Test tab.

The second tab is the “QUERY” tab which can be used for querying the database about a particular tag using the tags UID. The GUI of the Query tab consists of:

- A text box to allow the user enter the UID of the tag they need information about
- A “Search” button to initiate the query and connect to the database.
- The DibbioPack logo

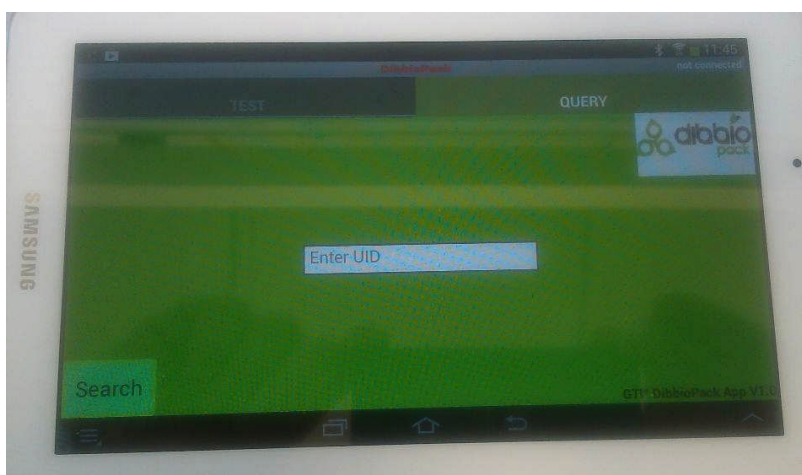

With regards to the operation of the App itself, the process is as follows:

- The user presses the button on the GTI reader, where they should see one flash.
- Next, the user opens the Dibbiopack App and presses the “Start” button.
- After being prompted to connect via Bluetooth, the user connects using the specified passcode.
- Upon connection, the user will see the green light flashing on the Reader.
- The reader is then ready to interrogate the package Tag for tracking and oxygen sensing.

During testing, the App buffers a single data line and stores the previously buffered data line on the remote server, but it will display each data line as soon as it is obtained from the Reader. When the user finishes testing and presses the Stop button, the last buffered data line is then stored in the (cloud) database. Upon connection, the text “Connected to Reader” is displayed in the top right-hand corner of the screen. When the Oxygen status is a Pass, the background of the oxygen status will become green indicating that everything is correct. On the other hand, if the oxygen status is a Fail, the background of the same window will start flashing a red colour to highlight the Fail status. A blue background will be shown if a ReScan is displayed. The various tag UID’s will be shown on a white background.

WP4 - INTEGRATION OF BIODEGRADABLE COMPOSITES MATERIALS, PROCESSES AND MULTIFUNCTIONAL SMART DEVICES

The first tasks were focused on the selection software, and more precisely on provide the structure of the matrix and the data that is going to be the basis for the software to be developed. Because three different process technologies are involved in DIBBIOPACK, namely injection moulding, extrusion blow moulding and film extrusion technology using different sets of process parameters, as well as transformation and methodology procedures/devices the possible combinations of these with newly materials developed in the scope of project is very high. To simulate the integrated processes and materials developed for specific application software was developed in order to be used as a tool for selecting the technically most adequate packaging solutions. For both Injection Moulding and Extrusion Blow Moulding a DoE were conducted. Based on the results of these experiments, some relevant results were used as an input for the comparative matrix. Furthermore, the rest of elements to be kept in mind for the matrix were studied, as antimicrobial activity, or health, energy and LCA parameters.

According to the given inputs from project partners a user friendly software tool was developed by TECOS using the Microsoft Visual Basic (VB) programming tool. This software makes it possible in a more professional way to start a developing procedure of different programs (applications...) that can be used in modern Windows environment. The used software is based on a visual programming language which makes it possible to develop the entire program also with visual tools so we could add for instance different buttons, check boxes, labels etc. so the software had a nice graphical user interface. Inside the software user is guided through a simple selection procedure where he selects the desired combination of process parameters for the interested material together with its properties in order to obtain the final result like value of thicknesses, dimensions, shrinkages etc. with integrated energetic cost, cycle times, health and security issues. In any case this developed software allows the user to simulate the integrated processes in the development of multifunctional packaging and can be used as a tool for selecting the technically most adequate packaging solutions. Using this software several different cases were tested in order check if the software allows to select the best theoretical solution based on the user requirements. For each possible process, lay-out can be also optimized, modifying processing conditions, materials or devices to reduce the number of steps or processing time to obtain an improved solution.



Figure 9. visualisation in VB environment.

On the next groups of activities, the definition of the pilot plans and lines took place. After several audio conferences organised between the end users (COSMETIC, HELP and NUTRECO) and the hosts of the pilot lines (AITIIP and TECOS), together with the mouldiest & injection moulding expert, TEHNOS, it was decided:

1. Layout of the pilot line (placement, simple draft of the PL)
2. Equipment
 - a. Machine → specifications of the machine
 - b. Peripheals → Vacuum? IML? Post-process tools for films?
3. Part
 - a. Specifications of the part
 - b. CAD design of
 - i. Part
 - ii. Mould (s)
4. Material to be used (with properties measured till now)

COSMETIC PILOT LINE

The final application for this demonstrator will be a cream jar, composed by a cap and the jar itself. It is going to be manufactured using injection moulding procedure. The first attempt was to fit both parts in the same mould, but this increase the unbalanced filling in the mould, leading to differences into packing pressures between cap and jar, causing deformations on the final parts that make unusable the final product. Finally, two moulds were manufactured for both parts. If we refer to the first drafts, the cosmetic application was to be something like this diagram below:

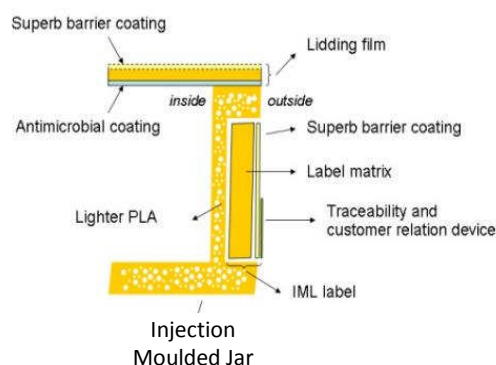

Figure 10. Initial cosmetic application

This was a simplification and a way to show a concept. Translating this into the real jar, we have a cap instead a film (all jars have closure caps and not films only. Maybe both on some cases). The cap can have the antimicrobial coating on the IML film that can be attached on the internal side of the cap. The IML with the barrier coating will be also on the outside of the jar and the jar will be foamed to reduce weight. The RFID is considered an option if it is cheap enough. Following the requirements of COSMETIC, the antimicrobial coating could be also optional and should be included if it is cheap enough. This is since cosmetics products contain high enough concentrations of preservatives to ensure very low microbial loads within the entire volume of the product.

Equipment: Machine

The injection machine where the pilot line was implemented is a **JSW J85 EL II** electric-assisted machine from 2002.

Table 2. specifications.

Injection Unit specifications:	JSW J85 EL II
Injection volume (max.)	97 cm ³
Specific injection pressure (max.)	1960 bar
Theoretical injection flow rate (max.)	188 cm ³ /s
Screw diameter	32 mm
Plasticisation capacity	17cm ³ /s
Nozzle type	Open
Clamping Unit specifications:	JSW J85 EL II
Clamping Force	85 Ton
Distance between columns	H: 360mm V: 360mm
Plate size	H _p : 530mm V _p : 530mm
Mould thickness range	Thickness _{min} : 180mm Thickness _{max} : 350mm
Opening Stroke max.	300 mm.
Clamping system	Toggle system



Figure 11. Peripherals It is expected to have a vacuum pump near the machine/mould in order to place the label on the IML system. Apart from that, no other external peripheral is expected.

The prototype part needs to be engineered for production so that it can be produced in a steel tool. Further requirements of a prototype design are also relatively even wall thickness with no undercuts, which would prevent the steel halves from opening or cause the part to be trapped in one-half of the tool. The gate, the location where the part is injected was determined and the flow of the material into the part was analysed and supported by simulation analysis. The geometries of jar and cap were designed following the end-user requirements and are shown of the figures below. Both parts have round edges, the locations of IML labels are envisaged and the closing of the lid is provided with a pin. The dimensions of complete final part (jar with a cap) are 53 mm in height and 83 mm in diameter. The cosmetic jar cap is Snap-On. Please note that it will have to be tight enough to prevent moisture loss and finally cream drying.

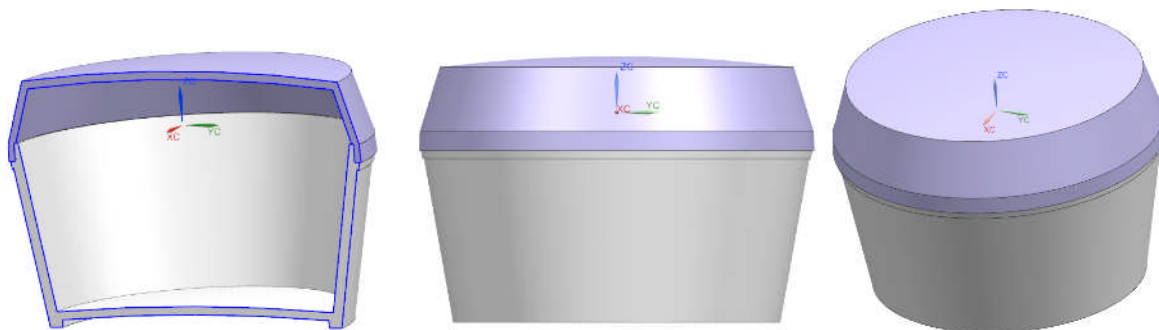

Figure 12. Jar with cap.

Manufacturing of mould

Moulds were constructed. They are similar in size and with IML system incorporated.

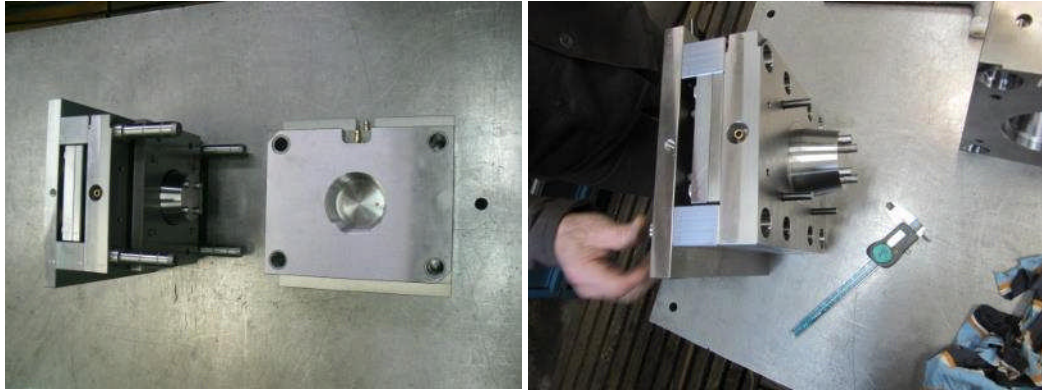

Figure 13. moulds.

Giving us as a result the first prototypes for the cosmetic Jar:



Figure 14. prototype of the cosmetic jar.

FOOD DEMONSTRATOR PILOT LINE

On this case, the final demonstrator is a tray for prepared food looking on the concept proposed on the DoW, the food application should be something like this diagram below:

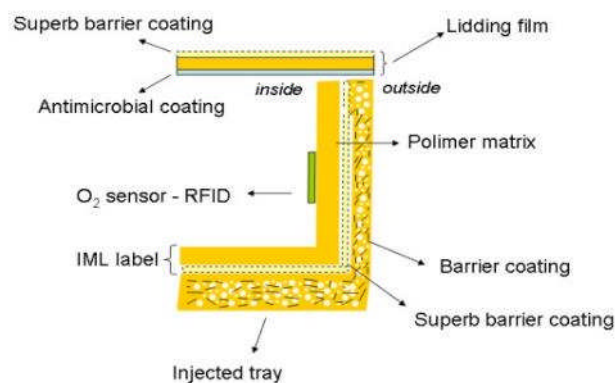

Figure 15. initial food application.

Finally, the injection moulded tray was made with reinforced PLA, and the inner IML label include antimicrobial coating and an Oxygen sensor. The division between the tray material with nanoadditives from the food itself has been achieved with these internal labels. The lidding film has also the superb barrier coating of the IML label. The location of the selected injection moulding machine will be on TEHNOS facilities.

Equipment: Machine

The injection machine, where the pilot line was implemented is a Krauss Maffei Injection machine - **KM160/SP750CX**.

Table 3. specifications.

Injection Unit specifications:	
Injection volume (max.)	251 cm ³
Specific injection pressure (max.)	2500 bar
Theoretical injection flow rate (max.)	188 cm ³ /s
Screw diameter	40 mm
Shot weight, PS	228 g
Nozzle type	open
Clamping Unit specifications:	
Clamping Force	160 ton
Distance between columns	H: 570 mm V: 520 mm
Plate size	H _p : 870 mm V _p : 845 mm
Mould opening force	86,4 kN
Opening Stroke max.	650 mm
Clamping system	Hydraulic



Figure 16. Peripherals It is expected to have a vacuum pump near the machine/mould in order to place the label.

CAD Part design

The geometry of a tray for food packaging was designed following the end-user requirements and is shown of the figures below. Tray is divided into two asymmetrical compartments with envisaged locations for absorbent pads. Tray has round edges, the locations of IML labels are foreseen on the inner side of the part and the gate locations are predicted for each compartment separately. Dimensions of a tray are 260 mm in length, 160 mm in width and 36 mm in height.

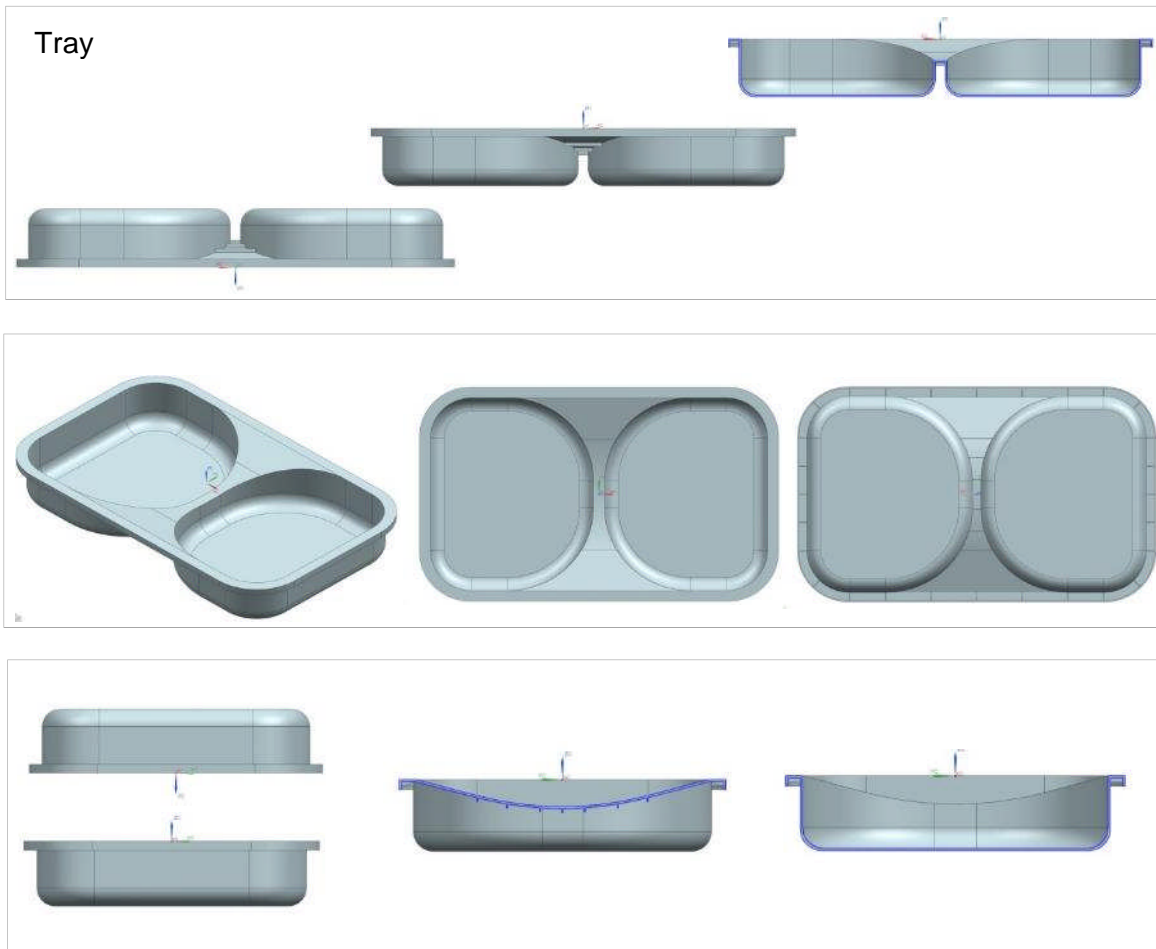

Figure 17. CAD parts of the tray.

Mould manufacturing

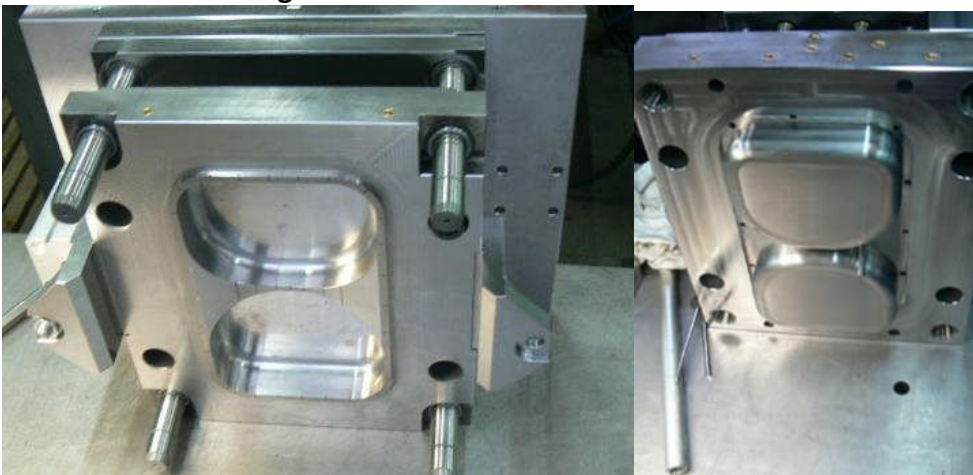

Figure 18. moulds.

Prototype manufacturing

The trials started with usual materials, first with PP. There was easy to set the right amount and speed of material based on experience from jar injection. Separating tray from mold after it was injected lead to a problem. The tray kept on fixed side of the mold. Another material was tested,

this time with ABS. The tray was harder but the difficulty with ejecting was not solved, so the mould modification had to be done. Additional air channels were produced and associate to special air valves to release vacuum in phase of mould opening. After repairing the mould, the tests with PLA started. The result was that the mould did not open after injection. The friction was strong enough to keep all the tree metal plates together. Removing the mould from the machine once more and additional polished was done, to finally produce the demonstrators.

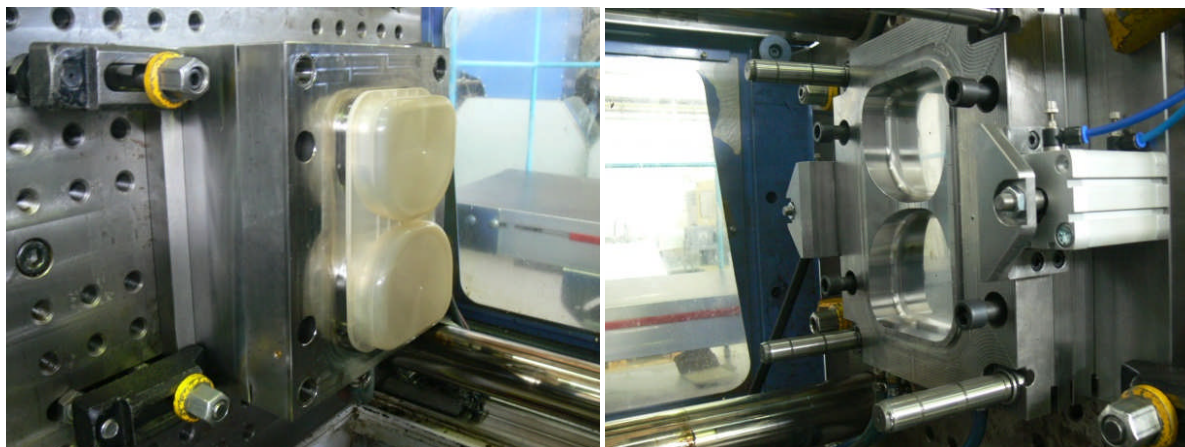

Figure 19. moulds.

After successful injection the tray looks like on the picture below:



Figure 20. tray prototype.

PHARMACEUTICAL DEMONSTRATOR PILOT LINE

General specifications and layout of the pilot line

On this case, the final demonstrator is a bottle for syrup or pills. Checking the concept proposed initially in the project, the pharmaceutical application was to be something like this diagram below:

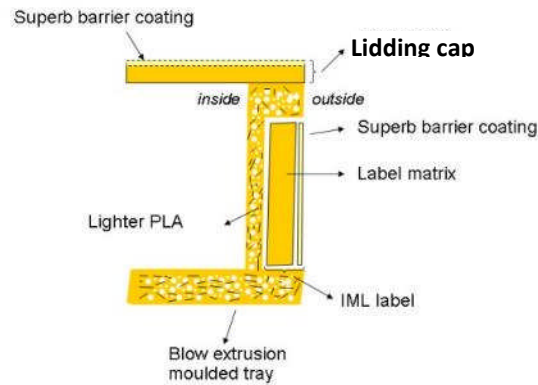

Figure 21. initial pharmaceutical application.

This time the production technology selected is Extrusion-Blow moulding. The bottle should be made with a lighter (foamed or SCF) and reinforced PLA. If the material is reinforced with nanoadditives, these can't be in contact with the product, so a pill application will be selected. For other applications, the internal surface should be covered by a superb barrier treatment, or an IML label (which is not possible on EBM on the internal surface). The equipment available on AITIIP does not allow having a multilayered extruded parison, so this solution of separation is also discarded. The outer IML label is, on the other hand, possible and could include a superb barrier coating,

The lidding cap should have also the superb barrier coating of the label on the inside or a treatment to assure the perfect closure. It is going to be manufactured another mould for the screw cap for this application. The caps are going to be injected in the same machine than the cosmetic application on AITIIP facilities and included on the pilot line as a part to be included in the "assembly".

The location of the selected injection moulding machine is on AITIIP facilities.

Equipment: Machine

The extrusion-blowing machine where the pilot line is going to be implemented is a Labtech LBM 125 / LE30C

Table 4. specifications.

Blowing and Clamping Unit specifications:	
Clamping capacity	600 kgf (6 kN)
Platen size H x W)	120 mm x 125 mm
Bottle size	100 cc – 250cc
Max distance between platens	180 mm
Min distance between platens	20 mm
Hydraulic motor power	2.2 kW
Hydraulic pressure (max)	50 bar (5 MN/m ²)
Die heaters:	a) Lower die heater 600 W b) Upper die heater 900 W

	c) Connecting pipe heater 250 W
Water supply	2 bar (min)
Compressed air supply	7 bar (min)
Extrusion Unit specifications:	
Screw diameter	30 mm
Screw L/D	30
Screw RPM	0 to 300
Motor power	7.5 kW
Heater power	8.9 kW

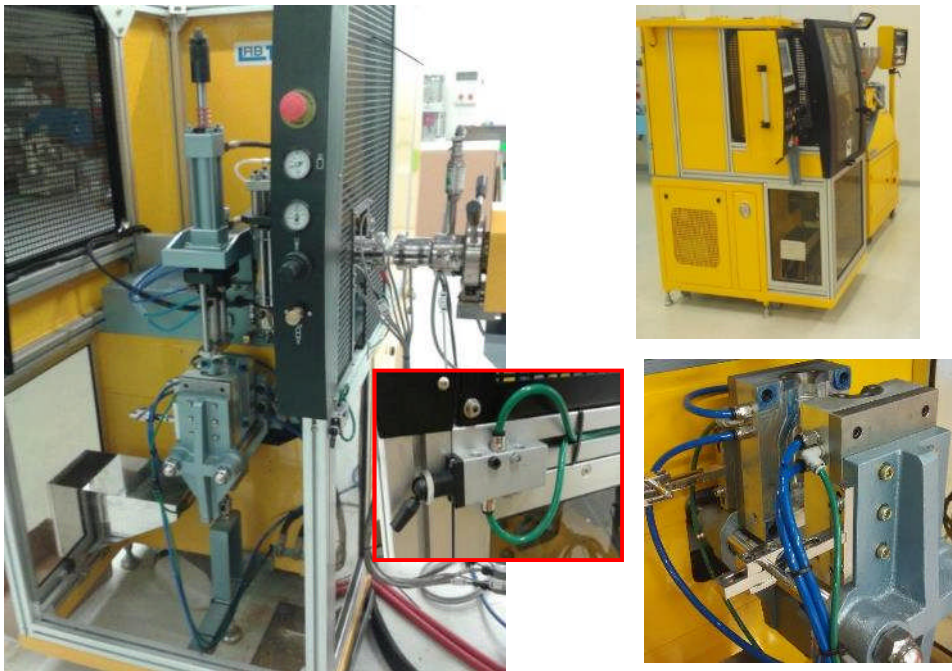

Figure 22. Peripherals

Finally, no vacuum pump is necessary, as we are using the own compressed air and Venturi effect to make the vacuum effect, but a mould temperature controlled should be used.

Figure 23. Part CAD designs

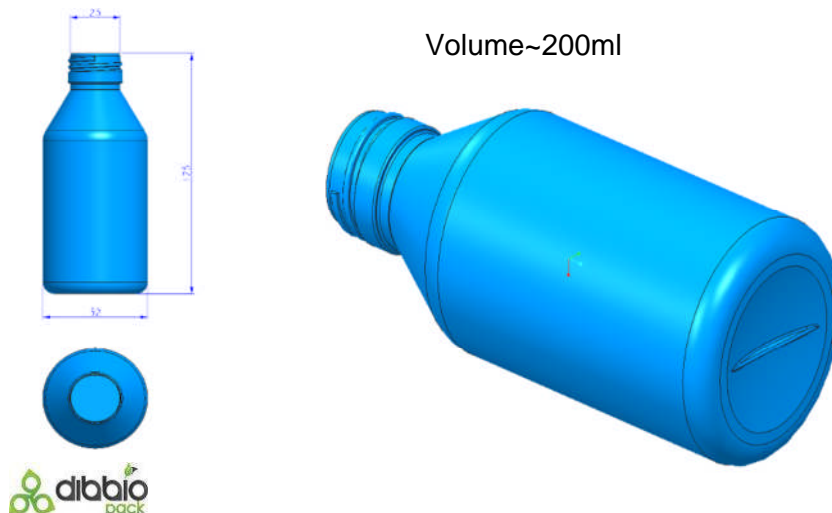



Figure 24. The constructed mould with the IML system operative



Figure 25. Bottle demonstrator.

WP5 - VALIDATION ON END USERS APPLICATION

Thin film studies were performed by ISC. For these tests the PLA thin films provided by Innovia (film thickness: 30 μm) were coated with the bioORMOCER[®] PCL-T-b-10 lacquer and the inorganic coating applied by PLASMA in the developed sandwich process. The water vapour transmission rate of these coatings was $<0.2 \text{ g}\cdot\text{m}^{-2}\cdot\text{d}^{-1}$ (23 °C, 100 % relative humidity, MOCON PERMATRAN-W[®] 3/61) and the oxygen transmission rate was $<0.5 \text{ mg}\cdot\text{cm}^3\cdot\text{m}^{-2}\cdot\text{d}^{-1}\cdot\text{bar}^{-1}$ (23°C, 50 % relative humidity, OXTRAN 2/21ML), respectively. To evaluate the potential of these sandwiched coatings, the combination of inorganic coating sandwiched by bioORMOCER[®] was applied on standard PET/SiO_x thin films. The resulting water vapor transmission rate in this setup was $0.02 \text{ g}\cdot\text{m}^{-2}\cdot\text{d}^{-1}$ (23 °C, 100 % relative humidity) and is comparable with state-of-the-art non-biodegradable coatings. The barrier properties on thick packagings are thus supposed to be even higher when extrapolated.

COSMETIC JARS

The overall migration tests were developed according to different methods depending on the used simulant and the application of the final jars. In general, the reference method applied was EN 1186:2002 “Materials and articles in contact with foodstuffs – Plastics”, detailed for different applications in:

- Part 4: Test methods for overall migration into olive oil by cell
- Part 9 Test methods for overall migration into aqueous food simulants by article filling

The overall migration was allowed to proceed for 10 days at 40°C. The total loss in mass is expressed in mg/dm^2 of surface area of the specimen and the overall migration is reported as the mean of a minimum of three determinations on separate test specimens. The results for the overall migration of cosmetic jars in all different simulants are presented. The packaging complies with the limits of 10 mg/dm^2 as total migration.

Overall migration for jars.

	UM	Result	Min.	Max.	Limit	METHOD
Vegetable Oil	mg/dm^2	8,3	7,2	9,2	10	EN 1186-4:2002
Ethanol (10% v/v)	mg/dm^2	4,5	3,4	5,6	10	EN 1186-9:2002
Acetic acid (3% w/v)	mg/dm^2	2,9	1,7	3,9	10	EN 1186-9:2002

Specific Studies:

The EN 13130 series deals with specific migration. The procedures used to bring and maintain the plastic in contact with the food simulant, procedures used for both overall migration and specific migration, are described in the EN 1186 series of standards.

According to these standards, the specific migration limit (SML) is a maximum permitted amount of a substance in food. This limit should ensure that the food contact material does not pose a risk to health. It should be ensured by the manufacturer that materials and articles not yet in contact with food will respect these limits when brought into contact with food under the worst foreseeable contact conditions.

Plastic materials and articles shall not transfer their constituents to foods in quantities exceeding the specific migration limits (SML) set out in Annex I of the Regulation 10/2011. Those specific migration limits (SML) are expressed in mg of substance per kg of food (mg/kg). For substances for which no specific migration limit or other restrictions are provided in the same Annex I, a generic specific migration limit of 60 mg/kg shall apply.

At the end of the prescribed contact time, the specific migration is analysed in the food simulant using an analytical method in accordance with the requirements of Article 11 of Regulation (EC) No 882/2004, in DIBBIOPack, the GC-FID analysis was used to determine the concentration of the main component present in the plasticizer Glyplast 206/3NL which has a SML equal to 18 mg/kg of simulant, as defined in Annex 1 of the Regulation.

For the exact identification of the chromatographic peak, the standard material of this substance was injected and identified as elution time (see Figure 1, blue line).

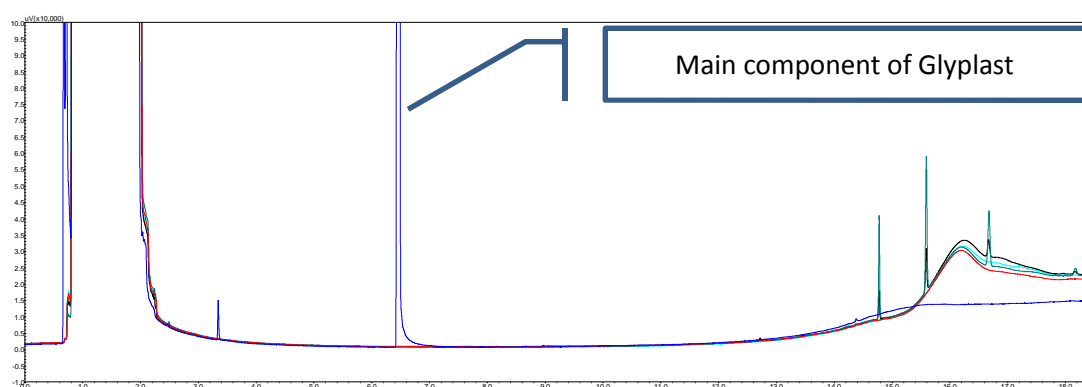

Figure 1. Chromatograms of the migration substances in Glyplast 206/3NL.

Blue line = Main component of Glyplast 206/3NL

Red line = Jar – test in ethanol 10% (v/v) as simulant

Green line = Jar – test in acetic acid 3% (w/v) as simulant

Black line = Jar – test in oil as simulant

All three extracted solutions (red, green and black lines in Figure 1) obtained by using three different simulants in contact with the jars showed no migration of this component and, consequently, the compliance with the Specific Migration Limit of the main component of the plasticizers used in the final DIBBIOPack Jars. To conclude it is possible to state that both for total and specific migration, the final formulation of cosmetic packaging complies with the Regulation EC No. 10/2011 (for food application).

COSMETIC received the prototype jars and caps. The batches of the 5 different typical cosmetic formulas: shampoo, massage oil, oil in water cream, water in oil cream and a sunscreen cream products for the testing have been prepared.

Stability tests of the PLA jar at 45°C for a month showed deformations with all 5 different products. The jars did not have any deformations at room temperature. The cosmetics in contact with the jar were looking similar to the control without any macroscopic or microscopic noticeable differences at 25°C and 45°C. A quite unexpected positive result was the improved stability tests with the Lumifuge of the W/O cream in the PLA jar compared to the PE jar. More specifically the instability index was improved by 20% at 25°C and 40% at 45°C.

Immersion tests were performed with dogbone shaped strips of PLA at 45°C to test possible swelling. All dogbones immersed at the shampoo, o/w cream, w/o cream and sunscreen cream gained weight approximately 1.5-2.9 %, only at the dogbones at the massage oil no significant changes in weight were detected.

The stability of 2 commonly used preservative systems (isothiazolinones and a mixture of sodium dehydroacetate and phenoxyethanol) in contact with the packaging (PE and PLA) was tested with efficacy challenge tests. The challenge test included the inoculation of the cosmetic with a high microbial load of a mixture of different standard microorganisms (*Pseudomonas aeruginosa*, *Staphylococcus aureus*, *Candida albicans*, *Escherichia Coli*, *Aspergillus brasiliensis*) and the measurement of the reduction of the viable colonies for each type of microorganism. The packaging did not have any significant effect on the preservation efficacy of the two preservative systems.

Overall we conclude that the PLA material compared to the PE exhibited similar or in one case better results in the stability of the product, while on the other hand it didn't show good results on the integrity of the packaging (at 45°C). Meanwhile, PLA packaging had no impact on the common preservation systems tested.

PHARMA BOTTLES

The overall migration tests were developed according to different methods depending on the used simulant and the final application of the final bottles and applied approximately for food packaging. Migration test conditions are the same as for jars (EN 1186:2002 "Materials and articles in contact with foodstuffs – Plastics" - Part 4: Test methods for overall migration into olive oil by cell and Part 9 Test methods for overall migration into aqueous food simulants by article filling).

The results for the overall migration of pharmaceutical bottles in different simulants are presented below. The packaging complies with the limits of 10 mg/dm² as total migration.

Overall migration for bottles.

	UM	Result	Min.	Max.	Limit	METHOD
Vegetable Oil	mg/dm ²	4,0	3,4	4,7	10	EN 1186-4:2002
Ethanol (10% v/v)	mg/dm ²	6,9	6,2	7,8	10	EN 1186-9:2002
Acetic acid (3% w/v)	mg/dm ²	1,4	0,8	1,9	10	EN 1186-9:2002

Similarly to the description of the experimental execution of the specific migration analyses for jars, the bottles were analysed for the determination of the specific migration of the main component of the Glyplast 206/3NL, which has a SML equal to 18 mg/kg of simulant.

For the exact identification of the chromatographic peak, the standard material of this substance was injected and identified as elution time (see Figure 1, blue line).

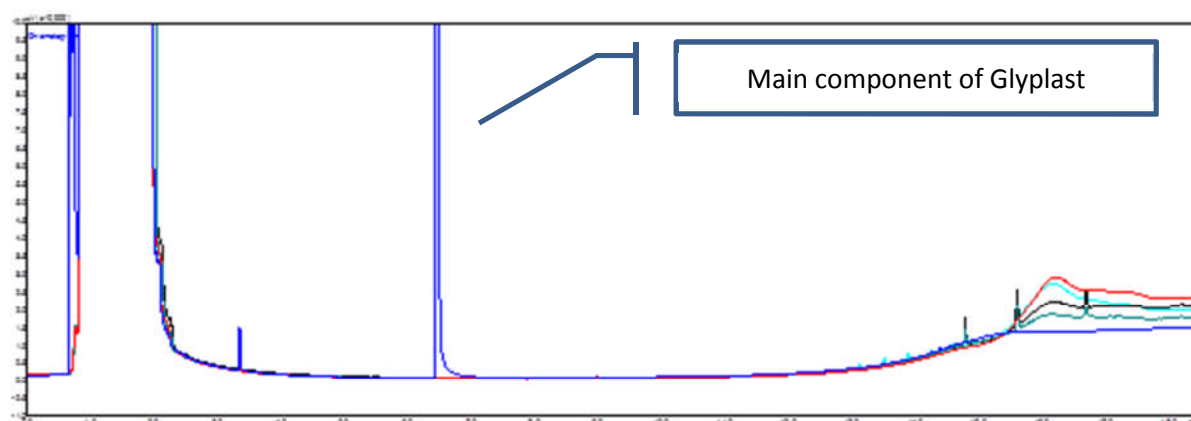

Figure 2. Chromatograms of the migration substances in Glyplast 206/3NL.

Blue line = Main component of Glyplast 206/3NL
 Red line = Bottle – test in ethanol 10% (v/v) as simulant
 Green line = Bottle – test in acetic acid 3% (w/v) as simulant
 Black line = Bottle – test in oil as simulant

All three extracted solutions (red, green and black lines in Figure 1) obtained by using three different simulants in contact with the bottles showed no migration of this component and, consequently, the compliance with the Specific Migration Limit of the main component of the plasticizers used in the final bottles formulation.

Regarding the total migration of the DIBBIOpack bottles, the tests showed the overall compliance with the limit of 10 mg/dm² in all tested simulants, according to the European Regulation EC N. 10/2011.

In addition, the test was replied for the determination of the specific migration, by looking for the migration of the main component of the Glyplast 206/3NL, used as plasticizer in the final formulation because this molecule has a SML equal to 18 mg/kg in all three used simulants: the analyses showed the absence of the migration of this substance, indicating the perfect compliance with the European Regulation.

The experimental results on bottles revealed that when it comes to pharmaceutical preparations, prototype containers showed adequate performance at long-term testing. The amounts of humidity measured, remained within specifications in both cases. As expected, the amounts of humidity were higher in the container without desiccant.

When it comes to accelerated testing conditions, in both cases the amount of humidity exceeded maximum permissible limits. Once again, as expected, the results obtained from experiments when conducted to containers without desiccant showed larger amounts of humidity and bigger variations. In addition, changes in shape of bottles and caps were observed at three month testing of accelerated conditions.

Although barrier properties measured by Fraunhofer Institute showed better barrier properties of material films (PLA combined with bioORMOCER® and inorganic layer from PLASMA), studies were conducted at 23

°C. Results obtained from testing of pharmaceutical capsules at 25 °C and 60% R.H, are complementary to the ones of Fraunhofer. On the other hand results obtained from accelerated conditions, set the product out of specifications, with humidity content exceeding the maximum permissible limit of 1.5%.

FOOD TRAY

The overall migration tests were developed according to different methods depending on the used simulant and the final application of the final trays (without PLA film). Migration test conditions are according to EN 1186:2002 “Materials and articles in contact with foodstuffs – Plastics”, in experimental conditions detailed from:

- Part 3: Test methods for overall migration into aqueous food simulants by total immersion
- Part 4: Test methods for overall migration into olive oil by cell

In Table 3, the results for the overall migration of food trays in different simulants are presented. The packaging complies with the limits of 10 mg/dm² as total migration.

Overall migration for trays.

	UM	Result	Min.	Max.	Limit	METHOD
Vegetable Oil	mg/dm ²	2,8	2,7	2,9	10	EN 1186-4:2002
Ethanol (10% v/v)	mg/dm ²	7,4	6,0	8,8	10	EN 1186-3:2002
Acetic acid (3% w/v)	mg/dm ²	5,3	3,1	7,6	10	EN 1186-3:2002

The total migration was determined for antimicrobial film, according to EN 1186:2002:

- Part 2: Test methods for overall migration into olive oil by total immersion
- Part 3: Test methods for overall migration into aqueous food simulants by total immersion

The results for the overall migration of food trays in different simulants were presented. The antimicrobial film complies with the limits of 10 mg/dm² as total migration. The final product “tray + antimicrobial film” complies with the Regulation No. 10/2011 because all the experimental results are below the limits of 10 mg/dm² as total migration.

The specific migration of tray (and its final formulation) was carried out to quantify the concentration of the main component present in the plasticizer Glyplast 206/3NL which has a SML equal to 18 mg/kg of simulant, as in the previous cases: for the exact identification of the chromatographic peak, the standard material of this substance was injected and identified as elution time

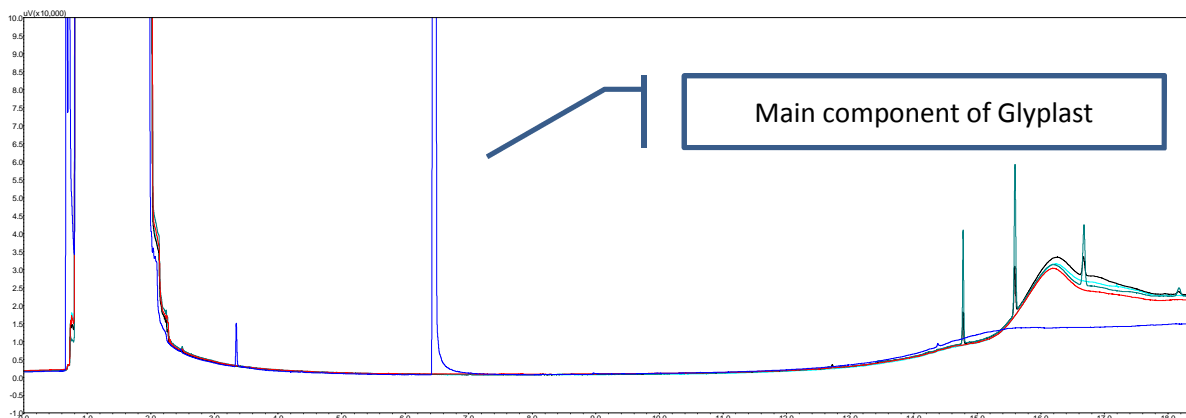

Chromatograms of the migration substances in Glyplast 206/3NL.

Blue line = Main component of Glyplast 206/3NL
Red line = Tray – test in ethanol 10% (v/v) as simulant
Green line = Tray – test in acetic acid 3% (w/v) as simulant
Black line = Tray – test in oil as simulant

All three extracted solutions (red, green and black lines in Figure 1) obtained by using the selected three different simulants in contact with the trays showed no migration of this component and, consequently, the compliance with the Specific Migration Limit of the main component of the plasticizers used in the final bottles formulation.

The specific migration test was not carried out on antimicrobial film because the Glyplast is not present in its final formulation.

In addition, the formulation for the antimicrobial treatment on film (ORM4a+10%mol PCL + ANDIB72_3, developed by ISC and Avanzare) has no component with the Specific Migration Limit defined by the Regulation. In these cases, the legislation defines that all the unregulated components must comply with the specific limit of 60 mg/kg of simulant.

In this way, if we consider the worst case from the total migration results (4,9 mg/dm² obtained from the test with Ethanol simulant), it's possible to obtain an experimental value of 29,4 mg/kg as the sum of the different constituents which complies with the specific limit of 60 mg/kg, independently from the chemical compounds used in the antimicrobial formulation.

Regarding the total and specific migration of the DIBBIOpack trays and antimicrobial films, the executed tests showed the overall compliance with the limit of 10 mg/dm² in all tested simulants for the total migration and the SML for the main component of Glyplast for specific migration compliance.

The conclusions of the experimental tests on trays can be concluded that

- We were not able to thermos-seal completely the PLA film. Due to problems with the ejector marks
- The shelf life of poultry wing packed with PLA trays and film was 6 days. The chicken nuggets, on the other side, increased its shelf life due to the expected action of the antimicrobial humidity release: Good results were observed in the case of further processing products (nuggets and marinated sirloins). At day 14 after package, although we were not able to package the product under modified atmosphere, the PLA active packaging maintained the shelf life of nuggets and marinated till 14 days without detectable signs of microbial spoilage.
- The antimicrobial coating was very effective also in to control gran negative bacteria total EB, total coliforms and E. Coli).
- The gas concentration in head space was very variable between replicates and the CO₂ was lost over the time due the permeability of Film.
- So further studies is needed to achieve better salability of PLA films but the packaging using antimicrobial coating was very effective to control natural spoilage microflora present in further processing products and gram negative bacteria.

WP6 - ASSESSMENT OF THE PACKAGING SUSTAINIBILITY, LCA, LCC AND ECOTOXICOLOGY

In the course of the project different products and their related processes were developed, as reinforcing nanofillers, antimicrobial nanoparticles, PLA plasticizers, lacquers and nanostructured coatings to improve barrier properties. At the same time, such products were used to develop specific manufacturing and application processes in order to produce the three types of final packages (trays, jars and bottles), PLA films to be used for labelling, and for the functionalization of the final packages.

Since one goal of the project was to assess the environmental and economic sustainability of all the DIBBIOPACK products, different horizontal activities run in parallel with the products and processes development, since the beginning.

In particular, the different grades of PLA suitable for film making, injection and blow extrusion moulding, their formulations with plasticizers and additives, as well as different ORMOCER® lacquer formulations were characterised in terms of biodegradability in composting conditions following the criteria defined in EN 13432 Standard.

Following the preliminary positive results obtained, also the final products:

- the nanofilled PLA-based bottle for pharma applications produced by extrusion blow moulding,
- the nanofilled PLA-based jar for cosmetic applications produced by injection moulding,
- the nanofilled PLA-based tray for food applications, produced by injection moulding, functionalized with antibacterial and barrier PLA-based films,

were tested to assess their compliance with EN 13432. Globally all products resulted biodegradable in controlled composting conditions (biodegradability $\geq 90\%$ in less than 180 days). Composts were non-phytotoxic and leachates of the composts had no acute effects on earthworm or daphnia. On the other hand the leachable fractions of the PLA based products had acute effects on environmental organisms (daphnia and algae) indicating that they pose environmental risk when they are left as waste and exposed to rainfall or end up in surface water.

In order to assess the environmental and economic sustainability of the developed products, **Life Cycle Assessment and Life Cycle Costing** study were performed along the whole supply chain, from raw materials production to product end life. For comparison, the same work was performed on specific selected product benchmarks, composed by synthetic polymers as HDPE, PP, PET.

According to the work performed the initial objectives has reached, assessing all impacts and related costs due to the manufacturing of the DIBBIOPACK products. It is necessary to highlight that the data used to perform LCA & LCC are derived from assumptions and experimental data obtained at most on small prototype scale, hence the values of the impact categories deriving from LCA and the process costs could be overdimensioned for DIBBIOPACK PLA-based products.

In terms of LCA, the developed DIBBIOPACK products showed positive environmental impacts. In particular PLA-based bottles and jars showed reduced impact with respect to the impact categories Marine aquatic ecotoxicity and Fresh water aquatic ecotoxicity, but higher impact with respect to Human toxicity and Global Warming Potential. PLA-based trays functionalized with PLA barrier and antimicrobial films showed lower impact with respect to Marine aquatic ecotoxicity, Fresh water aquatic ecotoxicity and Human toxicity, but higher impact with respect to Global Warming Potential (GWP). The higher GWP category for PLA-based products was recognized to be dependent on the contribution brought by the PLA as the main component, the plasticizer and the weight of the single products that is higher than that of the benchmarks.

Life Cycle Costing revealed that DIBBIOPACK products have nearly two times higher costs with respect to their benchmarks. The difference between the DIBBIOPACK products and their benchmarks is mainly due to the higher cost of the PLA with respect to synthetic polymer benchmarks as polyethylene and polypropylene. On the other hand, it is foreseen to have in the future a higher polymer market demand and more polymer producers, causing a PLA price reduction, to allow the new DIBBIOPACK products to be more competitive with their commercial benchmarks. Another important driver for the diffusion of the DIBBIOPACK products could be also the introduction of new regulations on packaging, in favour of fully biodegradable and compostable products, as it was the case of the shoppers.

Another expect considered in the course of the project was to perform health & safety risk assessment on new developed products and related manufacturing processes.

Risk assessment was performed either for working environment or for consumer/end user safety, with the aim of:

- Identifying hazards and exposure,
- Analyzing or evaluating the risk associated with the identified hazard and exposure,
- Providing good practice procedures to eliminate, minimise and further control the risk

Among the various hazards potentially linked with project objectives, a specific risk assessment was performed for **nanoparticles use**. Chemicals in nanoparticle form have properties that are completely different from their larger physical forms and may therefore interact differently with and in biological systems. As a result, it is necessary to assess the risks arising from any nanoparticle that will potentially come in contact with humans, other species or the environment, even if the toxicology of the chemicals that make up the nanoparticle is well known. Traditional approaches for risk assessment to substances cannot be applied yet to nanomaterials (NMs) due the uncertainty regarding the input data, including: a lack of consensus on the best exposure metric, not sufficient toxicological data to determine exposure limits and a lack of information on exposure-dose relationships.

An alternative approach is the utilization of Control Banding (CB) tools.. CB is a generic technique to prioritize occupational situations based on bands reflecting:

1. The likelihood of exposure to the particles
2. Their potential hazard (such as skin/eye irritant, very toxic, carcinogenic, etc)
3. A band of exposures (low, medium, high exposure) possibly taking into account control measures (for example dilution ventilation, engineering controls, containment etc.) (NIOSH, 2009)

During the project the qualitative ‘control banding’ web based tools Precautionary Matrix (TEMAS, 2013) and ‘Stoffenmanager Nano’ (TNO, 2011) were used for prioritizing the potential human health risks caused by worker inhalation exposure to nanoparticles. In total six nanomaterials were evaluated when used in five different workplaces.

The Precautionary need for workers derived from the Precautionary Matrix and the Risk priority for workers derived from the Nano stoffenmanager were not always comparable. The highest risk priority was given to NanoFiber T (nano sepiolite clay), because of their fibrous character. Because the exact hazard for fiber-like manufactured nano objects, including NanoFiber T, has not yet been established, the severity of the potential health effect and the uncertainty relating the presence of a subsequent threshold, warrants the classification of nanofibers in the highest hazard category (E) in Nano Stoffenmanager. Because NanoFiber T is selected in the demonstrators (bottle, jar, food tray) it would be recommended to perform human toxicological testing evaluations for the product NanoFiber T. These results could establish if the fibre like properties initiate an acute toxicological effect or inflammation and oxidative stress.

The highest Precautionary Need for workers and the environment was determined for ANDIB73 and 92 (nano-ZnO). This was caused by the small size (non-agglomerating), handling of bigger amounts (including waste), high oxygen radical formation potential and high induction potential for inflammatory responses. Because Nano ZnO is used in the foil covering the food tray it was recommended to examine the possible diffusion of nano ZnO into the food matrix. The toxicological influence of ZnO-NPs should be evaluated to determine the consequences of using these NPs in food packaging.

Because of the antibacterial effects of nano ZnO this waste should be handled with extra care and should not reach the environment by flushing down the drain or in regular waste. This waste should be collected within labelled, closed containers and offered to a disposal company.

For all different NP processes within the Dibbiopack project precautionary measures were described which can be applied by the partners in Standard Operating Procedures (SOPs) at their facilities.

Harmonization of different nano control banding strategies is recommended to obtain only one risk evaluation for the use of one nanomaterial in a process.

The last topic addressed in the project was to produce an overview of different **waste management European systems**, with the aim of providing recommendations for integrated recycling solutions. Such task was performed analysing different countries considering their different waste recovery rates as Germany (high recovery rate of packaging waste), Spain (medium recovery rate), United Kingdom and/or Greece (medium to low recovery rate). The study also included the countries from which the project partners were. The study was focused in the waste management of two specific flows: packaging waste and organic waste, because the new packages developed in the project can be classified in any of these two waste streams. As it was expected, the main legislation in each country is a transposition of the Waste Framework and Packaging and Packaging Waste Directives. Packaging waste management must fulfil the “extended producer responsibility” forcing the producers to be responsible for the waste management of the products they put into the market. So, Integrated Management Systems has been established in nearly all the Member States. Additionally, some countries have implemented Devolution, Deposit and Return systems (for example in Germany, Belgium) for some specific kind of packages (commonly beverages) but these systems are not so widespread. In relation to organic waste, the EU legislation doesn’t establish the obligation of separate collection of biodegradable waste, so the different countries have developed different policies in its management.

The Dibbiopack packages are intended to be managed in a way that let them to be finally treated in industrial composting facilities. They were designed with that objective in mind and they have also been tested according to the norm EN 13432 on industrial compostability.

The different options for the waste management of these packages are analysed in the deliverable D6.7 *Report on the overview of different waste management European systems*. It also includes some conclusions and recommendations in relation to this issue.

Potential impact (including the socio-economic impact and the wider societal implications of the project so far) and the main dissemination activities and exploitation of results

The new improved biodegradable materials have a clear potential impact into the plastic packaging industry, as well as other related industries. In the project the consortium has demonstrated the improvements and the possibilities of replacing some commodities in the medium term, always keeping in mind the necessary regulatory changes in two different ways: the first empowering the use of biobased and biodegradable plastic materials and the second paving the way for a correct waste management of these kinds of materials. With these actions the use of these materials will be increased, which will impact into an improvement of the environment and the (not) dependence of fossil resources but renewable ones.

Process parameters optimised for industrial scale operations on injection moulding and extrusion blow moulding process technologies coupled with in mould labelling and supercritical fluid operational systems, are stated as the most important achievements gained through the project course activities. Know-how acquired for the development of novel Dibbio materials on up-scaled production levels and recommendations for its industrial processability performances is also an important asset from the perspective of conquering a new upraising market of biomaterials intended for many applications and industrial uses, including devices and plastic components for medical/health care, utility vehicles, packaging items, agriculture, construction and marine products, home appliances, etc.

From the flexible packaging market perspective a majority of customers' value plastic labels and lidding materials that are highly transparent with high gloss finish as this maximises on-shelf appeal of the product and this has therefore become a key target for the PLA films developed in the scope of Dibbiopack project. Targets on optimising the film extrusion technology for novel Dibbio materials to produce PLA films on a large scale; this meant scaling up laboratory scale work to either industrial or "large" pilot scale facilities were profitably achieved. It has been demonstrated that BO-PLA films can be produced on both a lab scale and a pilot scale with key scale up parameters to industrial scale defined.

Till now there has been no knowledge on how to industrially process biodegradable materials enhanced with nanofillers and functionalise with plasticizer additives. As it was revealed throughout the research project work, biopolymer materials reinforced with nanoclay fillers are extremely difficult to process, regardless of the evolved processing techniques (injection moulding, extrusion blow moulding, film extrusion, in mould labelling, SCF). The R&D knowledge gained through the Dibbiopack project will enable the project partners to market their experience and help companies to quickly and seamlessly transfer their products from oil-based polymers to bio-based and bio-degradable products.

New biodegradable functional coating materials based on the combinatorial design of inorganic coating and hybrid polymers referred as BioORMOCER, was developed during Dibbiopack project. The competitive advantage of the mentioned innovation is the offer of biodegradable functional coating materials to improve the barrier properties of biodegradable films or to add additional functionalities to a packaging material such as antimicrobial properties. The main innovation is that this new material class offers an adaptable biodegradable refinement finishing of polymer films.

Following the activities performed in WP6 and especially those related to biodegradability and ecotoxicity sample assessment, ARCHA has gained further experience in the field of bioplastics and their additives and consolidated its network at EU level, which were exploited in its own business as R&D & analytical service provider. In particular, it is worth to mention the participation of ARCHA to new projects with AITIIP in a LIFE project (MULTIBIOSOL LIFE 14 ENV/ES/486) and with AITIIP and ISC in a H2020 - BBI.VC1.R3 project (still under evaluation) both related with biodegradable films. At the same time ARCHA also exploited its experience in LCA&LCC as well as in H&S risk assessment at EU level participating to 2 LIFE project submitted on the 2015 call and 2 BBI calls (BBI.VC3.D5 and BBI.VC1.R3-2015) related with biobased products, all still under evaluation.

VITO: the “safety by design” principles could be demonstrated in this project for the bioplastics and their additives. The concept for safety + risk assessment based on (a) LCA, scientific and modelled data and (b) on experimental data for simulated exposure and ecotoxicity / in vitro testing will be further developed and applied to other types of materials. VITO will be involved in the safety assessment of nanobased materials in (a.o.) the projects NANOTUN3D (EU Project reference: 685952) and Met@Link (sponsored by IWT).

In the case of SOGAMA, being part of this project has increased its knowledge about biodegradable packages and the possible challenges that could appear in the treatment of their wastes. This will help to be prepared and it also opens new possibilities for considering new projects.

Regarding the exploitation of the results, below is a summary, the complete detailed report is included on the Plan for using and disseminating of foreground.

KER 1a: Materials formulations for specific processes

It joins the diverse formulations for each type of process (EBM, IM) on the project, including the last improved formulations using more biodegradable elements (as OLA2 from Condensia Quimica instead of Biostrength).

The competitive advantage is the optimisation of the formulation has been made specifically for the use of biodegradable materials and this processes. The main innovation is the improvement of the mechanical and thermal properties based on Nanomaterials and plasticizers.

The exploitation clearly is as a PRODUCT, through Licensing to a Third Party (already existing, any spin off) AITIIP offers their spin-off (TECNOPACKAGING, which is highly interested) to do so and the partners don't show any inconvenient.

PLA and Biostrength could be bought directly to external partner. In the case to use finally OLA2 instead of Biostrength, only raw material should be purchased. CQSA and AVANZARE can sell to the Licensee their additives to produce the material or can provide them and get benefits like the other partners interested.

The other partners interested can get a % from the benefits obtained from sales or get material formulation for free (up to a max per year, i.e.). If necessary to patent the formulation(s) at EU level could be done to protect the development a little bit, but this kind of protection on formulations are not strong. Sometimes is better to keep the formulation as a “secret”.

KER 1b: bioORMOCER

The result is the biodegradable coating which is a Functionalized biopolymer + different alkoxysilanes and hetero element precursors, with differing amount of biopolymer depending on the application.

The competitive advantage is the offer of a biodegradable functional coating material to improve barrier properties of biodegradable films or to add additional functions to a packaging material such as antimicrobial properties. The main innovation is that this new material class offers an adaptable biodegradable refinement finishing of polymer films.

The exploitation way chosen is first, PATENT. Then license to a third party interested (no one identified yet, as is still on patenting process? Anyway, the lacquer would have to be produced by a material supplier, who has been given the license of producing the lacquer. Afterwards the producer of the coatings would have to buy the material from the material supplier

KER 2a: Processes adapted to be used for Direct Industrial Use or as a service for other companies.

This result consists in the process parameters optimised and more important, the know-how acquired for development of biomaterials or products using these materials.

Till now there has been no knowledge on how to industrially process biodegradable materials enhanced with nano fillers. As it was discovered in the research work done in the project, special those one enhanced with nano fillers are extremely difficult to process regardless of the process techniques (injection moulding, extrusion blow moulding, film extrusion, in-mould labelling)

The knowledge gained will enable the project partners to market their experience and help companies to quickly and seamlessly transfer their products from oil-based polymers to bio-based and bio-degradable products.

Furthermore, regarding Extrusion compounding, can be claimed as innovation the optimised preparation of the formulation, such as pre-treatment of nano-additive with fluid plasticizer in order to promote feeding in the extruder and reduce spreading in the environment. Preparation of PLA/plasticizer pre-mix and maintenance of the masterbatch in moderate temperature allowing plasticizer absorption by the polymer, very useful in formulations with 5% plasticizer.

Optimised processing and content of additives to stabilise properties and morphology of the products for long time of storage before use.

The chosen exploitation way is as a SERVICE to companies in the case of AITIIP (IM, EBM, Extrusion compounding), TECOS (IM) or INSTM (Masterbatch preparation), directly.

KER 2b: Coating on films

The initial intention was to somehow patent the process or at least to find the way to exploit the layer by layer process among the partners involved. Finally this result is not intended to be exploited. During the project was demonstrated that the logistics of this process among three partners makes not feasible to exploit it by the partners. If it is found a third party that joins all the needs –being able to deposit R2R the bioORMOCER, and then to deposit PLASMA inorganic layer- the process will be licensed by the partners PLASMA, ISC and INNOVIA.

KER 3: Oxygen sensor

This result consist of the development of an RFID enabled Oxygen sensor, incorporating RFID Reader, Optical Sensor and Bluetooth module in a compact, handheld unit for the monitoring of tagged products and the development of traceability and customer relation devices capable of communicating and stored all data related to the product in a cloud based database, which can be accessed via an Android application from any Smart phone or Tablet computer.

The design and development of a wireless sensor system and associated software, which meets the requirements of the food packaging partners to automatically detect an increase in oxygen levels within the target product, and therefore indicate a breach of the packaging via the ISC oxygen indicator.

The oxygen indicator is combined with an RFID tag to add a unique identifier (UID) to further allow full traceability of Modified Atmosphere Packaging (MAP) products from manufacturer to point of consumption.

The exploitation way chosen is licensing for a third party industrial use, as NUIG or ISC does not have the capabilities of exploiting directly for Direct Industrial Use, but the appropriate partner has not been identified yet.

KER 4a: Food tray

KER 4b: Pharma bottle

KER 4c: Cosmetic jar

The final results are the demonstrators themselves. After the last tests, the partners were able to evaluate the possibility of exploitation of the solutions. All of them were interest into do so, but only after some improvements on the final characteristics and adapting to a real geometry, which will imply own investments and resources from a partner interested on their further sell. TECNOPACKAGING, the spin-off of AITIIP is a great candidate, but at the moment of this report

writing is still studying its feasibility. A third party ready to perform this improvement necessary to its exploitation is necessary, because the thermal resistance, intrinsic to the PLA was the most important drawback for all of them. The sensor for food packaging also did not work as precisely as end user needs, but with some adjustments, it could work.

- The address of the project public website, if applicable as well as relevant contact details.

Coordinator: Berta GONZALVO

Tel: (+34) 976 46 45 44

Fax: (+34) 976 47 61 87

E-mail: berta.gonzalvo@aitip.com

Project website: www.dibbiopack.eu

4.2 Use and dissemination of foreground

A plan for use and dissemination of foreground (including socio-economic impact and target groups for the results of the research) shall be established at the end of the project. It should, where appropriate, be an update of the initial plan in Annex I for use and dissemination of foreground and be consistent with the report on societal implications on the use and dissemination of foreground (section 4.3 – H).

The plan should consist of:

- Section A

This section should describe the dissemination measures, including any scientific publications relating to foreground. **Its content will be made available in the public domain** thus demonstrating the added-value and positive impact of the project on the European Union.

- Section B

This section should specify the exploitable foreground and provide the plans for exploitation. All these data can be public or confidential; the report must clearly mark non-publishable (confidential) parts that will be treated as such by the Commission. Information under Section B that is not marked as confidential **will be made available in the public domain** thus demonstrating the added-value and positive impact of the project on the European Union.

Section A (public)

This section includes two templates

- Template A1: List of all scientific (peer reviewed) publications relating to the foreground of the project.
- Template A2: List of all dissemination activities (publications, conferences, workshops, web sites/applications, press releases, flyers, articles published in the popular press, videos, media briefings, presentations, exhibitions, thesis, interviews, films, TV clips, posters).

These tables are cumulative, which means that they should always show all publications and activities from the beginning until after the end of the project. Updates are possible at any time.

TEMPLATE A1: LIST OF SCIENTIFIC (PEER REVIEWED) PUBLICATIONS, STARTING WITH THE MOST IMPORTANT ONES

NO.	Title	Main author	Title of the periodical or the series	Number, date or frequency	Publisher	Place of publication	Year of publication	Relevant pages	Permanent identifiers ¹ (if available)	Is/Will open access ² provided to this publication?
1	<i>Economic transformation in Hungary and Poland'</i>		<i>European Economy</i>	<i>No 43, March 1990</i>	<i>Office for Official Publications of the European Communities</i>	<i>Luxembourg</i>	<i>1990</i>	<i>pp. 151 - 167</i>		yes/no
2										

¹ A permanent identifier should be a persistent link to the published version full text if open access or abstract if article is pay per view) or to the final manuscript accepted for publication (link to article in repository).

² Open Access is defined as free of charge access for anyone via Internet. Please answer "yes" if the open access to the publication is already established and also if the embargo period for open access is not yet over but you intend to establish open access afterwards.

3										

TEMPLATE A2: LIST OF DISSEMINATION ACTIVITIES

NO.	Type of activities ³	Main leader	Title	Date/Period	Place	Type of audience ⁴	Size of audience	Countries addressed
1	<i>Conference</i>		<i>European Conference on Nanotechnologies</i>	<i>26 February 2010</i>				
2								
3								

³ A drop down list allows choosing the dissemination activity: publications, conferences, workshops, web, press releases, flyers, articles published in the popular press, videos, media briefings, presentations, exhibitions, thesis, interviews, films, TV clips, posters, Other.

⁴ A drop down list allows choosing the type of public: Scientific Community (higher education, Research), Industry, Civil Society, Policy makers, Medias, Other ('multiple choices' is possible).

Section B (Confidential⁵ or public: confidential information to be marked clearly)

Part B1

The applications for patents, trademarks, registered designs, etc. shall be listed according to the template B1 provided hereafter.

The list should, specify at least one unique identifier e.g. European Patent application reference. For patent applications, only if applicable, contributions to standards should be specified. This table is cumulative, which means that it should always show all applications from the beginning until after the end of the project.

TEMPLATE B1: LIST OF APPLICATIONS FOR PATENTS, TRADEMARKS, REGISTERED DESIGNS, ETC.					
Type of IP Rights ⁶ :	Confidential Click on YES/NO	Foreseen embargo date dd/mm/yyyy	Application reference(s) (e.g. EP123456)	Subject or title of application	Applicant (s) (as on the application)

⁵ Note to be confused with the "EU CONFIDENTIAL" classification for some security research projects.

⁶ A drop down list allows choosing the type of IP rights: Patents, Trademarks, Registered designs, Utility models, Others.

Part B2

Please complete the table hereafter:

Type of Exploitable Foreground ⁷	Description of exploitable foreground	Confidential Click on YES/NO	Foreseen embargo date dd/mm/yy yy	Exploitable product(s) or measure(s)	Sector(s) of application ⁸	Timetable, commercial or any other use	Patents or other IPR exploitation (licences)	Owner & Other Beneficiary(s) involved
	<i>Ex: New superconductive Nb-Ti alloy</i>			<i>MRI equipment</i>	<i>1. Medical 2. Industrial inspection</i>	<i>2008 2010</i>	<i>A materials patent is planned for 2006</i>	<i>Beneficiary X (owner) Beneficiary Y, Beneficiary Z, Poss. licensing to equipment manuf. ABC</i>

In addition to the table, please provide a text to explain the exploitable foreground, in particular:

- Its purpose
- How the foreground might be exploited, when and by whom
- IPR exploitable measures taken or intended
- Further research necessary, if any
- Potential/expected impact (quantify where possible)

¹⁹ A drop down list allows choosing the type of foreground: General advancement of knowledge, Commercial exploitation of R&D results, Exploitation of R&D results via standards, exploitation of results through EU policies, exploitation of results through (social) innovation.

⁸ A drop down list allows choosing the type sector (NACE nomenclature) : http://ec.europa.eu/competition/mergers/cases/index/nace_all.html

2. FINAL REPORT ON THE DISTRIBUTION OF THE EUROPEAN UNION FINANCIAL CONTRIBUTION

This report shall be submitted to the Commission within 30 days after receipt of the final payment of the European Union financial contribution.

Completed by Alma / AITIIP

Report on the distribution of the European Union financial contribution between beneficiaries

Name of beneficiary	Final amount of EU contribution per beneficiary in Euros
1.	
2.	
n	
Total	