

1 Final publishable summary report

1.1 Executive Summary

SUSTRAIL is the acronym for the EU Framework 7 collaborative research project with grant number 265740. It addressed theme SST.2010.5.2-2: “The sustainable freight railway: Designing the freight vehicle – track system for higher delivered tonnage with improved availability at reduced cost”.

The aim of the SUSTRAIL project was “to contribute to the rail freight system to allow it to regain position and market”. To achieve this, a consortium of European experts was formed and considered combined improvements in both freight vehicle and track components in a holistic approach including economic assessments. Achieving a higher reliability and increased performance of the rail freight system as a whole contributes to an increased profitability for all stakeholders making rail freight more attractive. This final report provides a summary of work that occupied almost 70 person-years.

In the context of strong growth in road transport and a forecast growth in volumes of freight its aim was “to contribute to the rail freight system to allow it to regain position and market”, aligned with a target of the European Commission. The project was undertaken by a balanced consortium of infrastructure managers (IMs), freight operators, companies involved in the rail sector, and academics.

SUSTRAIL considered a combined improvement in both freight vehicles (with a targeted increased in speed and axle-load) and track components (for higher reliability and reduced maintenance), and also the interactions between them. A holistic approach was adopted; benefits to freight and passenger users (since mixed routes were considered) were quantified through the development of appropriate business cases to ensure profitability for all stakeholders.

The project activities culminated with the demonstration of the innovations studied for the freight vehicle and track components carried out in the last period of the project. It should be highlighted here that after a significant effort produced for the design and simulation, a prototype vehicle has been built and ran on a test track to establish the viability of the vehicle innovations. This prototype vehicle shown excellent results in terms of fulfilment of the requirements set at the beginning of the project and is available for future developments for a sustainable and efficient freight transport.

1.2 Summary Description of Project Context and Objectives

SUSTRAIL is the acronym for the EU Framework 7 collaborative research project with grant number 265740. It addressed theme SST.2010.5.2-2: “The sustainable freight railway: Designing the freight vehicle – track system for higher delivered tonnage with improved availability at reduced cost”. In the context of strong growth in road transport and a forecast growth in volumes of freight its aim was “to contribute to the rail freight system to allow it to regain position and market” (Description of Work), aligned with a target of the European Commission. The project was undertaken by a balanced consortium of infrastructure managers (IMs), freight operators, companies involved in the rail sector, and academics.

SUSTRAIL considered a combined improvement in both freight vehicles (with a targeted increased in speed and axle-load) and track components (for higher reliability and reduced maintenance), and

also the interactions between them. A holistic approach was adopted; benefits to freight and passenger users (since mixed routes were considered) were quantified through the development of appropriate business cases to ensure profitability for all stakeholders.

During the initial phase of the project we studied the context into which the SUSTRAIL innovations would be introduced. We analysed the regulatory framework that any innovations in track or vehicle should comply with, particularly the six Technical Standards for Interoperability (TSI) relevant to the SUSTRAIL project and the UIC leaflets on standard construction measures and operating procedures. Also, due to the diversity of the European rail freight industry, thorough benchmarking studies were carried out at three diverse freight systems, operating on routes in Spain, Bulgaria, and the UK. The future logistics requirements for freight on these three routes were analysed.

A particular effort was dedicated to the Business Case for the SUSTRAIL project. It was integrated into the project early on, with duty requirements defining what the rail industry needs and would benefit from (in terms of technical innovations in the vehicle and track) to meet the overall objective of increasing the traffic and market share of rail freight. The key technical innovations proposed within the project were assessed using: LCC (Life Cycle Cost), RAMS (Reliability, Availability, Maintainability, and Safety), and cost benefit analyses.

The duty requirements included: optimizing axle load limits, increasing freight operating speeds, reducing energy use, and reducing forces causing damage to the track. Other factors were also taken into account such as improved aerodynamics, environmental noise mitigation and easy integration with the existing fleet, maintenance procedures and safety standards. The cost-benefit analysis included financial analysis of the impact on IMs, train operators, end users, and government and a socio-economic cost-benefit analysis covering all parties.

Since innovations cannot be considered truly useful if they are not implemented, it was also important to consider the potential barriers to their implementation and demonstrate reasons to adopt them; part of this was considering the financial interface between IMs and freight operators.

Rolling stock innovations were proposed to improve vehicle design resulting in reduced operating costs for both vehicle and track, and reduced environmental impact. One of the main rolling stock innovations developed as part of the project was the **SUSTRAIL Freight Bogie (patent pending)**. This was based on the established Y25 type bogie and incorporated the following technologies:

- **Double ‘Lenoir link’** primary suspension to improve the curving properties of the system and reduce damage to the track
- **Interconnecting links** providing longitudinal and lateral stiffness between the axle boxes (to improve running behaviour and reduce wheel wear)
- **Noise reduction technologies:** brake disks, and spring inserts
- **Braking system:** brake discs, redundant pneumatic back-up system, wheel-slide protection
- **Condition Monitoring:** weighing valves installed in the bogie for local load monitoring; electro-pneumatic braking control with diagnostic functionality; thermocouple and accelerometers on each axle box
- **Power Supply:** Bearing generator with battery back-up and intelligent power management
- **Reduced weight:** use of high strength steels, and optimised section designs
- **Protective axle coating**

Computer simulations were used to assess various combinations of the technology improvements and to establish critical speeds and optimal design parameters for the new primary suspension system. Other analyses and tests were carried out as appropriate: e.g. both ballistic tests and non-destructive tests were carried out on axles with and without the coating; finite element analysis of the bogie.

Regarding the **vehicle structure**, the project aimed to develop an adaptable, intermodal flat wagon, addressing three main design criteria: lightweight; increased capacity; and sustainable, low-cost solutions (including recycled materials and interchangeable components). The vehicle body used novel high strength steel grades and cold formed profiles, optimised spigot disposition, sustainable flooring material, and lightweight covers.

Other innovations that did not feature on the vehicle were studied as ‘virtual demonstrators’. These included:

- Measures for reducing aerodynamic drag including logistics aspects of loading
- Options for locomotive traction
- Friction control: recognised to reduce environmental pollution, vibration, noise, and the cost of operation and maintenance; tests were carried out on the effect of friction modifiers in the contact zones of both wheel and rail, and wheel and brake shoes.
- Monitoring the structural integrity of axles (using low-frequency vibrations and acoustic emissions).
- Energy harvesting systems for powering condition monitoring equipment

Infrastructure Innovations were also considered to improve the resilience of the infrastructure system, reduce costs, and improve track accessibility. There was a strong link between this work and the vehicle work since the vehicle design directly affects track deterioration and vice versa. The work considered many aspects of infrastructure: rail, support (including ballast, transitions, and reinforcements), switches and crossings, and wayside condition monitoring. Innovations were selected by the infrastructure managers using a ‘failure modes and effects analysis’ (FMEA). Following this, a wide range of testing and simulation work was undertaken to produce models, recommendations, and procedures.

A few highlights:

- development of ‘Minimum Action Rules’ for corroded rail
- mechanical testing of insulated joints
- the use of advanced rail materials to combat wear, and rolling contact fatigue
- testing of lubricants for slide plates
- optimisation of the support stiffness in the area of the crossing panel (under-sleeper pads)
- optimising transitions
- vehicle defects that can be detected by dynamic force monitoring and associated maintenance limits

The **SUSTRAIL prototype vehicle** has been built and laboratory and track tests to establish the viability of the innovations it incorporates were carried out in the last period of the project.

As well as the SUSTRAIL prototype vehicle, four track innovations have been tested on mainline infrastructure:

- Premium rail steel
- Earthwork-stabilising geo-textiles with inbuilt monitoring sensors
- Under-sleeper pads
- Wayside monitoring of vehicles

Other innovations included modelling approaches and monitoring equipment that could reduce uncertainties and result in more robust maintenance regimes for track, switches and crossings, and associated structures.

1.3 Description of the Main S&T Results/Foregrounds

1.3.1 SUSTRAIL Context

This chapter contains a summary of the main results achieved in Workpackage 1 “Benchmarking” and Workpackage 2 “Duty Requirements”. The aim of WP1 was “to provide information to support evaluation of the key system parameters which will ultimately influence and determine improvements towards freight sustainability and competitiveness”, while WP2 was to “define duty requirements for vehicles and track to potentially double the life of track components when combined with low impact vehicles”.

1.3.1.1 Benchmarking

SUSTRAIL Workpackage 1 aimed to provide a benchmark of the current freight ‘system’ to establish the existing ‘zero state’ for subsequent comparative and enhancement activities. The benchmarking was designed to provide information to support evaluation of the key system parameters that will ultimately influence and determine improvements towards freight sustainability and competitiveness.

Data collection focussed on three selected European railway routes, identified by number on Figure below:

- the Mediterranean Corridor in Spain
- the Bulgarian route from the Serbian border to Turkey
- two key intermodal freight routes in the UK, from the ports of Southampton and Felixstowe to the North West of England

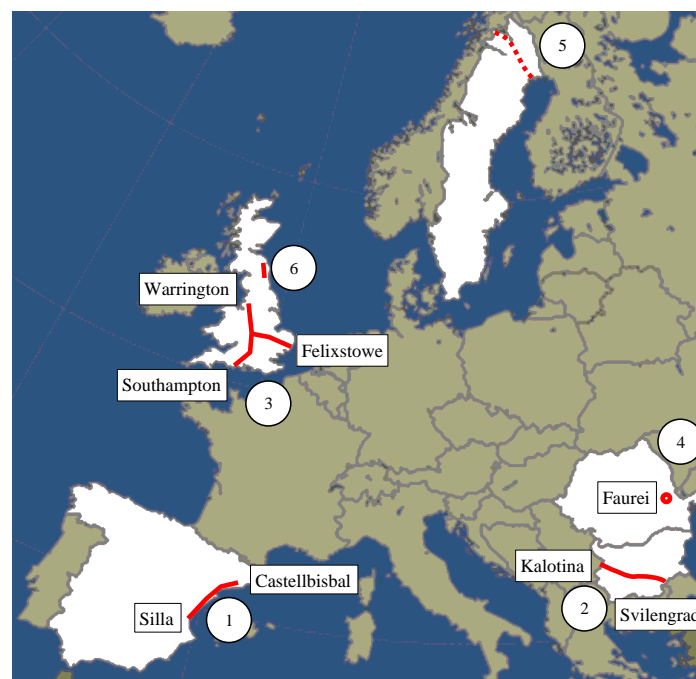

Figure 1: SUSTRAIL routes

These are all mixed traffic routes providing a wide diversity upon which to assess the freight system throughout Europe encompassing a wide range of freight, asset conditions, climatic influences and social/economic/cultural differences.

Also, tests and measurements were carried out at the test track at AFER's Railway Testing Centre Faurei (route 4, not to scale), which is the site of for demonstrations in Work Package 6.

Workpackage 4 made use of data from the Malmbanan heavy iron ore line in the north of Sweden (route 4 on figure) and the Wooden Gate site on the UK's East Coast line (route 6, not to scale).

Capacity modelling was conducted to provide benchmarking of the current freight 'system', to establish the existing 'zero state' for subsequent comparative and enhancement activities. The benchmarking is designed to provide information to support evaluation of the key system parameters that will ultimately influence and determine improvements towards freight sustainability and competitiveness.

The two categories of wagons most commonly used on the selected routes and beyond, in partner countries, were flat wagons (as used for carrying containers) and open high-sided wagons. There are several variations of these that increase the commodities that they can transport.

The ages of wagons in operation, as reported to the SUSTRAIL project, covered a wide range (4 to 37 years). The highest proportion of older wagons (over 30 years) was observed to operate on the selected route in Spain.

The Y25 bogie and versions thereof was reported to be the most common and widely used for freight wagons.

Most wagons were equipped with tread brakes / shoe brakes.

1.3.1.2 Future Logistics Requirements

Along the routes, as in the whole of Europe, there had been a steep decline in rail freight carried after the year 2008. This was an impact of the economic downturn resulting from the financial crisis. In order to not to draw the wrong conclusions from the development in rail freight along a route both general and route-specific developments need to be taken into account.

In general it is expected that freight traffic will increase significantly and the European efforts to increase interoperability and remove barriers to entry will encourage new operators to compete on the network.

Spain

Currently Spanish rail freight holds only 5% of the land freight market. The Mediterranean Corridor has the potential to increase capacity, as current freight volumes are significantly low.

This may be achieved through the development of rail freight into new markets alongside car parts and bulk commodities. A higher market share could also be captured through improved links with intermodal transport, a move to encourage modal shift from road to rail freight, and integration with the wider European Network. To accommodate increased freight volumes, it should be possible to increase train length and the number of wagons per train. Also, increasing freight speed to match that of passenger trains would reduce problems with their interaction.

If improvements can be made both locally (e.g., double-tracking the whole route) and to its integration with the European network, then a significant increase in utilisation might be expected.

Bulgaria

Rail freight in Bulgaria has approximately a 10 per cent share of total goods carried by surface transport. However, the EU has recognised the importance of the route as it has the ability to

transport a wide variety of freight. With improvements to the line, including double tracking throughout the route, and the rolling stock the increases in capacity and potential are very significant. There is potential for the average number of wagons per train to increase; however, further research is needed to clarify any restrictions regarding train length along this route. It is expected that increasing the average speed of freight along this route from 75 km/h to 120 km/h will lead to an increase in capacity. However, for such a scheme to be successful, significant investment in infrastructure along the route would be needed.

The main growth is expected to be of semi-finished and finished goods, textiles, and agricultural produce from Turkey heading toward Western Europe; it can be expected that the share of goods transported to and from the plants of the heavy industry, especially the metallurgical industry, will further diminish. There may be a slight increase in the share of coal and petroleum, as the economic development of the country of Bulgaria will go hand in hand with an increased use of energy.

United Kingdom

It is estimated that over 25% of freight containers originating from the Far East and shipped into ports like Southampton and Felixstowe are now transported onwards by rail. In the UK, rail freight will continue to grow by 26-28% by 2014/2015, compared with the year 2007. Important future market segments will remain the carriage of coal (for power production), ore (for the steel industry), and containers (for all kinds of cargo).

Consumer goods transported in containers have been the fastest growing goods category in rail freight over the past six years. Even the more moderate growth prediction of 4% would underline the containers' relevance for rail freight.

Another significant aspect is that there are plans to develop new port facilities at Bathside Bay on the other side of the estuary near Harwich, which would increase the number of trains from the combination of Felixstowe and Bathside Bay to 56 trains per day in 2030, which would increase the share of containerised rail freight.

The future planned expansion of the port of Felixstowe includes a third terminal capable of taking trains up to 30 wagons in length. In the port of Southampton, there is work underway to increase maximum train length to 775m. Average train length is therefore expected to increase, and this will require investment in loops on the network and at terminals.

The demand for Class E ordinary high-sided wagons is still high and will always keep an important share on the market due to specific types of freight (bulk and aggregates), but the capacity available from the existing fleets is more than sufficient. An increase in the transportation of biomass is predicted to take 1/3 to 2/3 of the coal market over the next 15 years. New market segments are most likely the transportation of high value, low mass goods.

Within WorkPackage 2 an important prioritization methodology was adopted to judge duty requirements against the objectives: availability; cost; service quality; environmental footprint; and technical viability. All proposed SUSTRAIL innovations must meet the essential duty requirements unless a strong case emerges for a change in standards. In addition, SUSTRAIL innovations are being designed to improve conditions for rail freight in the EU, so the main focus has been on determining what those improvements should be, in terms of the parameters targeted, the direction of change, and in some cases where previous research evidence exists, the magnitude of the target. At the next stage of SUSTRAIL (in WP3, 4, and 5) models were developed to refine these requirements for improvement and to carry out interim assessments of proposed technologies and engineering solutions.

Emerging from the prioritisation a **set of duty requirements** was produced which:

- together address the full set of SUSTRAIL objectives. Individually the duty requirements cannot achieve this: packaging the improvements together is important to achieve the desired outcome on each objective.
- Are judged to offer the best prospect of success within three years’ research, and subsequent implementation. There is mix of lower- and higher-risk research topics, however the potential reward also varies. High priority was given to a set of improvements which attempt to balance these considerations.

Table below rates these High/Medium/Low priority, with the implication that: High priority items should be pursued most urgently, using the majority of the resources, at the next stage of the research; Medium and Low items shall be given less priority, however even the Low items have potential – their Low priority reflects greater risks and/or smaller apparent rewards.

Table 1: Research Priorities from Duty Requirements

Priority Level	Duty Requirements for Improvement	System
High	1. Modest increase in freight speed (e.g. 120-140kph UK; 100-120kph ES,BG) 3. Optimise axle load limits (22.5t / 25t / 17-20t) 7. (20%) reduction in energy used by rail vehicles + Vehicle Green Label 12. Improve bogie design to reduce lateral forces (by 50%)	whole whole vehicle vehicle
Medium	5. Reduce vertical ride force to match passenger vehicle at equivalent axle load (by suspension improvements) 8. (20%) reduction in unsprung mass of freight vehicle 2. Uniform vertical stiffness (track) - optimise between 50-100 kN/mm 9. Optimise (potentially double) service life of track components 10. Combine components that have a similar service life (harmonise MTBF) 6. Reduced rate of tolerable defects 4. More reliable insulated rail joints (life*5)	vehicle vehicle track track track track track
Low	11. Independent power supply (wagon or train based) - for braking & refrigeration 13. Increased loading space	vehicle vehicle

The following key requirements were identified:

- With reference to “suspension and running gear” a reduction in damage to the rail and track in terms of derailment; track vertical settlement; rail damage and lateral force is required.
- By having a **combined wheel-slide and brake control system** the SUSTRAIL freight vehicle’s wheels will be in a better condition and will therefore be less damaging to the track.
- Analysis of accelerations and speed requirements showed that currently greater time savings can be obtained by **increasing the speed up to 120 km/h** whilst less benefit can be achieved by increasing from 120 km/h to 140 km/h, mainly due to speed limits imposed by railway crossings, switches, tight curves, and steep gradients.
- Aerodynamics investigations, primarily from the perspective of the associated drag, pointed out a series of options to **improve the aerodynamics of the freight vehicle** and highlighted, for intermodal wagons, the relevant effect of operational factors such as vehicle choice and loading regime.
- Finally with reference to noise mitigation, for the range of operating speeds of the SUSTRAIL wagon, rolling noise will be the dominant source. Since increasing the running speed from 120 km/h to 140 km/h (or higher), will increase the rolling noise, a possible approach is to fit, or retrofit, the wagon with **composite tread brakes or perhaps even disk brakes**.

In discussions between project partners and industry stakeholders the following overall specification was agreed:

- 1) Axle load: Current axle load limits in Europe are typically 22.5 or 25 t. It is proposed that the SUSTRAIL vehicle will be designed to allow a maximum axle load of 25 t. All structures and components and systems are specified accordingly. It has however been determined that the market for high-value low-density time-sensitive goods is increasing and for this reason it is highly likely that the SUSTRAIL vehicle will very often be carrying loads that do not result in full use of this capacity. For these reasons the SUSTRAIL vehicle will be capable of running at a maximum axle load of 25 t but will have an optional lower loading capacity limit.

- 2) Speed: Freight vehicles operate at very high speeds on some parts of the network in many European countries. It is not realistic to expect the SUSTRAIL vehicle to operate at these very high speeds and it must be noted that an increase in speed generally results in an increase in wheel-rail forces and in higher aerodynamic drag and energy consumption. Rates of vehicle and infrastructure damage are often strongly influenced by vehicle speed. However, research has shown that system capacity can be significantly increased if freight trains operate at the same speed as passenger trains. For these reasons it is proposed that the SUSTRAIL vehicle will be capable of operating at 140 km/h when carrying low-density goods but that there will be an optional lower speed limit for the vehicle running at the highest axle load condition.

This overall specification is summarised in table below.

SUSTRAIL vehicle specification		Max axle load (t)		
		17	22.5	25
Max speed (km/h)	120	YES	YES	YES
	140	YES		

Table 2: The SUSTRAIL vehicle speed and axle load specification

1.3.2 Rolling stock innovations

The specific aims of SUSTRAIL Workpackage 3 ‘*The freight train of the future*’ were to “*identify the key areas where recent and imminent developments can lead to improved running behaviour of railway vehicles resulting in reduced system maintenance and operating costs for vehicle and track, reduced environmental impact and greater sustainability and efficiency*”.

The work was split into three stages: a ‘Technology review’ which aimed to collect information on all existing and potential innovations that could be incorporated into the SUSTRAIL vehicle design; a ‘Concept design stage’ which matched the innovations against the duty requirements and produced the basic concepts for the SUSTRAIL vehicle; and a ‘Detailed design stage’ which took the concept designs and refined and optimised them using computer simulation and other techniques. These were then coordinated into a series of final designs that were used to build the SUSTRAIL demonstrator vehicle in the ‘Technology demonstrator’ workpackage.

1.3.2.1 The SUSTRAIL technology review

The technology review considered most aspects of relevant freight vehicles (including design of bogie subsystems such as suspension, structures, and wheelsets), and the traction of freight locomotives; see Table 3. A large number of potential innovations were identified, many of which

would give significant potential benefits. A selection process was then undertaken involving all workpackage partners. The selection procedure used the performance requirements identified earlier in the project to produce an overall weighted priority index (WPI) for each of the innovations. On the basis of these scores key innovations were selected and concept designs produced for the SUSTRAIL demonstrator vehicle. Other high-scoring innovations became the subjects of simulations or lab tests: “virtual demonstrators”. For each of the key innovations further work was carried out to refine the design and to select parameters of key components prior to defining the final design for the SUSRAIL freight vehicle.

Table 3: Matrix of technology innovations

Focus area	Innovation	WPI ¹	Demo ²
Running gear	Modified Y25 primary springs	7.40	D
	Rubber springs	6.14	X
	Double Lenoir dampers	6.78	D
	Wedge dampers	6.06	V
	Hydraulic dampers	6.07	V
	High resistance damping material	6.18	D
	HALL bushes	6.12	X
	Pusher springs	6.00	X
	Steering linkages	6.42	V
	Centre pivot stiffness	6.03	V
	Axle coating	7.19	D
	Novel wheel steel	7.14	D
	Novel wheel shape	6.97	D
Resilient wheels	4.29	X	
Traction and braking	Disk brakes	6.52	D
	Electronic distributor	6.38	D
	Independently rotating wheels	3.58	V
	Use of friction modifier at wheel	5.74	V
	Brake pad with friction modifier	6.35	X
	Traction motor "Induction"	6.51	D
	Traction motor "Permanent Magnet"	6.69	V
	Power electronic drive "Multi level topology M2C"		V
	Power electronic drive "Silicon Carbide SiC"		V
	Energy storage "Batteries"	5.13	D
	Energy storage "Ultra capacitors"	5.66	D
Medium frequency transformer for AC-grid		V	
Body and bogie structures	Lightweight bogie based on novel materials	5.78	V
	Lightweight bogie based on hybrid solution	5.99	V
	Lightweight bogie based on shape and components	6.89	D
	Composite bogies	4.94	X
	Aerodynamic fairings	6.22	V
	Light weight body based on novel steels	6.61	D
	Light weight body based on aluminium alloys	6.33	X
Light weight body based on Composite materials	5.36	D	
Condition monitoring	Axle monitoring through acoustic emission	6.21	V
	Axle monitoring through vibration measurements and acoustic emissions	7.07	D
	Energy harvesting	6.61	D
	Machine vision technology for monitoring wheels	5.42	X
	Thermal sensors to monitor axle boxes	5.87	D

¹WPI (Weighted Priority Index): Calculated by weighted sum of partners’ assessments. Weights: Compliance with duty requirements (from D2.5), 0.1; Technological benefit, 0.1; Production costs, 0.1; Availability for mass production, 0.15; Reliability, 0.25; Maintainability, 0.175; Sustainability (energy consumption, damage), 0.175

²Demo: (inclusion in SUTRAIL demonstrator): D, physical demonstrator; V, “virtual demonstrator”; X, not studied

It was noted that several of the innovations have been developed to prototype stage in earlier projects, but very few have been incorporated into production freight vehicles. The main reasons behind this were considered to be economic (costs of acquisition, monitoring, and maintenance), with logistical issues of phased introduction and maintenance planning also being relevant. These aspects were considered for SUSTRAIL's innovations in the business case workpackage.

1.3.2.2 The SUSTRAIL Bogie

The concept design for the SUSTRAIL freight vehicle bogie presented here includes a number of significant innovations in the running gear, wheelsets, braking system, bogie structure and in the adoption of condition monitoring. Despite this, most of the innovations selected are based on proven technology and this reduces the commercial and operational risks and increases the potential reliability and overall chances of success of the SUSTRAIL vehicle. In view of the key requirements of integration of the SUSTRAIL vehicle with the existing fleet and the existing maintenance procedures and safety standards, the WP3 partners took the decision to base the SUSTRAIL vehicle on the well-established Y25 type bogie.

Innovations that would integrate with the Y25 comprise:

- **Double 'Lenoir link' primary suspension:** in order to improve curving properties of the system a primary suspension configuration with double Lenoir links (i.e. a link on each of the springs) was chosen for the SUSTRAIL vehicles. With double Lenoir links the longitudinal stiffness of the system is reduced and the maximum longitudinal motion between the axle-box and bogie frame increased compared to a standard Y25 bogie.
- **Longitudinal linkages:** in order to improve the running behaviour of the SUSTRAIL vehicle it was decided to assess the benefit of linkages providing longitudinal and/or lateral stiffness between the axle boxes using a radial arm. This was studied in the Infra-Radial project which aimed to develop a bogie for heavy haul vehicles (axle loads over 25 t) with reduced life cycle costs. The Infra-Radial tests using the radial arm with four different primary suspension types showed good results with stable running and radially aligned wheelsets in curves. Wear of the wheels was seen to reduce significantly.
- **Centre pivot secondary suspension:** the secondary suspension of the Y25 bogie is realised by a centre pivot bearing and two side bearers. The pivot bearing provides three rotational degrees of freedom. Between the upper part connected to the carbody and the lower part connected to the bogie frame there is a plastic layer with a dry-film lubricant defining the friction and the relative motion without play. The side bearer enables a roll movement between carbody and bogie frame and provides a frictional damping for yaw movements of the bogie frame. Overall, this typical secondary suspension for freight wagons is very stiff in the vertical direction.

Simulations were carried out for a vehicle with double Lenoir links both with and without radial arms in order to calculate the critical speed. In these simulations wagon movement was simulated on a straight track with irregularities positioned at the distance of 40 m from the start with velocity reducing from 160 km/h to 40 km/h. The critical speed was assumed to have been reached when the total lateral force (ΣY) dropped below 2.5 kN. Analysing the results of various simulations showed that:

- 1) The critical speed for a laden wagon without radial arms is 107 km/h and for a similar empty wagon it is 80 km/h.

2) The highest critical speed (not less than 140 km/h) can be achieved by the following stiffness of radial arm:

- laden wagon: K_y more than 750 kN/m (critical speed of laden wagon is almost independent of longitudinal stiffness K_x)
- empty wagon: K_y more than 40 kN/m and K_x not more than 250 kN/m or K_y and K_x both more than 250 kN/m

3) To achieve a critical speed of 140 km/h for the wagon (for either loading condition), the radial arm should provide 750 kN/m of lateral stiffness. It need not provide any longitudinal stiffness.

As part of the optimisation of the primary suspension other parameters were varied, including the vertical coil spring stiffness, the ‘angle’ and length of the Lenoir link, the longitudinal offset between ends, the friction coefficient at the sliding surfaces (through changing material), the vertical clearance to the bump stop.

Following extensive computer simulations as described above the parameters for the various components of the running gear for the SUSTRAIL bogie were selected. Designs for the longitudinal arms were produced and a prototype constructed by the Romanian manufacturing partner. As a result of the computer simulations it was decided not to adopt the resilient secondary suspension and a standard UIC centre bowl arrangement was instead used for the SUSTRAIL vehicle. In addition to the innovative suspension, the vehicle has disk brakes with an electronic control system. A CAD model of the bogie design is shown in figure below.

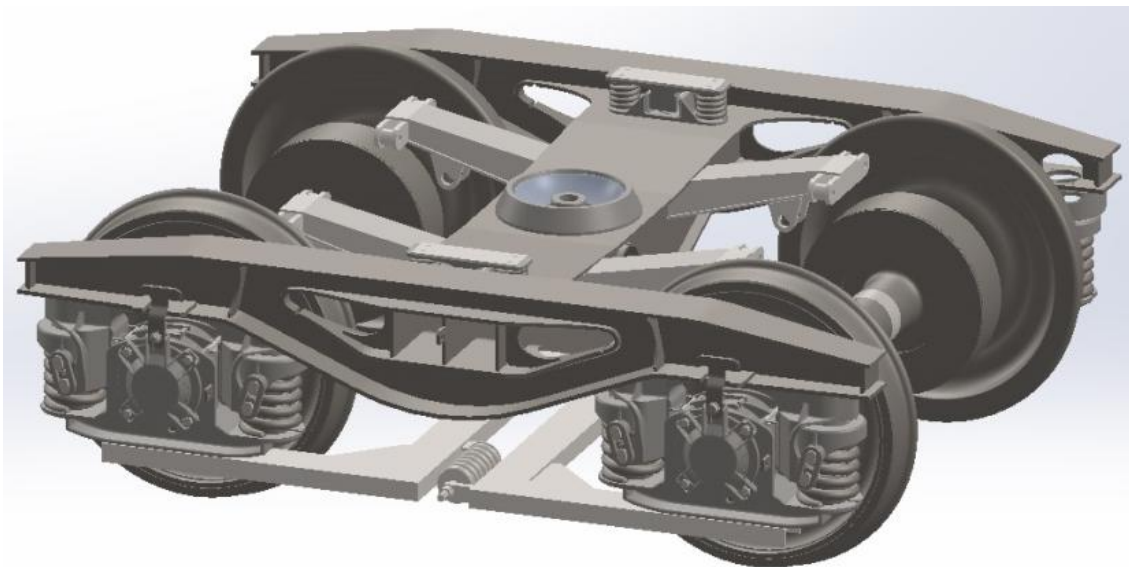

Figure 2: CAD model of the prototype SUSTRAIL freight bogie

Other innovations included in the SUSTRAIL bogie comprise:

- **Axle coating:** A new axle coating developed by Lucchini RS, shown on the SUSTRAIL vehicle wheelsets has been selected. The coating provides improved corrosion resistance, compared with traditional coatings, and resists impacts in a wide range of temperatures (-

40°C to 150°C). So, it protects the axle and limits the possibility of crack initiation even under aggressive conditions; this can reduce maintenance costs.

- **Friction modifiers:** friction modifiers can be used to control or vary the friction coefficient in different areas of the wheel and rail and tests of their effectiveness were carried out to establish the potential benefits for the vehicle and track. The laboratory research has shown the satisfactory properties of the tested friction modifiers for interacting surfaces of wheel and rail and wheels and brake shoes.
- **Braking system:** The braking system, as with the rest of the SUSTRAIL vehicle, aims to use recent and imminent innovations to produce an innovative high performance freight vehicle to allow the vehicle to function at an increased speed of 140 km/h while still delivering reduced impact and greater efficiency to allow the market needs to be met. The system used for this project is a combined system containing brake control and wheel-slide protection functions due to the required basic conditions. For improved availability and safety, these functions use separate components. Similarly, redundancy was designed into crucial functional units of the brake control.

1.3.2.3 Vehicle structure

The SUSTRAIL project aimed to develop the outline design of an innovative intermodal flat wagon that would respond to increased flows of intermodal loading units, which include ISO containers, swap bodies and semi-trailers, and was flexible and adaptable for other commodities, as well.

The SUSTRAIL vehicle upgrades focused on three criteria:

1. Lightweight design (bogie, frame, overall structure)
 - Materials selection
 - Hybrid Solutions (shape, components, dimensions and materials)
 - Structural design (shape and components)
2. Increased capacity
 - Greater and more flexible payload
 - Improved availability
 - Multi-functionality (different commodities)
3. Sustainable, low cost solutions
 - Interchangeable and inexpensive components and parts (couplers, wheelsets, buffers, etc.)
 - Sustainable materials (e.g. recyclable or recycled)
 - Reduced maintenance

The innovative wagon concept addressed the following challenges:

- Lightweight structural solution
- Multi-purpose and flexible structure
- Modular design
- Commonality and interoperability
- Sustainable engineering solutions (in relation to materials, design, and manufacturing)

The design process was guided by the project objective of increasing overall tonnage throughput. The vehicle outline design, including the detailed designs of its structural parts, considered the following crucial inputs:

1. The innovative concepts relating to the key challenges for SUSTRAIL freight wagon (i.e., lightweight, multi-purpose, modular, flexible and sustainable)
2. The duty requirements, specifications, and recommendations from previous work
3. The boundaries defined by standardisation, regulation, and manufacturing capabilities

Consequently, various innovative technologies, materials, and designs were selected for possible inclusion in the SUSTRAIL freight wagon. After some analysis the list of proposed innovative solutions was refined and the final selected upgrades and subsequent activities are summarised in Table 4.

Solution / task	Main objectives
Optimisation of wagon length and disposition of spigots	Increase capacity (efficiency)
Novel steel products for lightweight vehicle structure (wagon and bogies): <i>i.</i> steel grades (i.e. high strength steels) <i>ii.</i> novel profiles (e.g. cold formed)	Lightweight
Side walls <i>i.</i> construction options/stanchions <i>ii.</i> material: light composites, etc.	Increase capacity (efficiency), lightweight
Floor from recycled / recyclable materials (e.g., polymers)	Increase capacity (efficiency), costs, lightweight, recyclability
Tarpaulin cover	Increase capacity (efficiency), lightweight
Selection of components: based on TSI and commonality (buffers, coupler, bolster, etc.)	Cost-efficiency, low maintenance
Lightweight aerodynamic fairings (e.g. composite)	Environment (noise)
Integration of monitoring systems	Increase performance, low maintenance

Table 4: Summary of SUSTRAIL freight wagon upgrades

Overall, the study has shown the following:

- The weight reduction through steel grades replacement and profiles optimisation is possible and sustainable; a mass reduction of the wagon structure **up to 30%** can be achieved using this design concept;
- The replacement of conventional steel with high strength steel contributes to a significant reduction of the CO₂ footprint (see Figure 3), saving thus a relevant amount within the life cycle cost due to reduced fuel consumption;
- The fabrication costs were estimated to remain at a similar level, or even to decrease with approximately 5-10% due to lower labour costs;
- The recommended quality of the welds in the webs and flanges is normal, with some extra penetration in the bottom flanges in critical sections;
- A special attention shall be paid to welding specifications when high strength steels are used; the welds inspection has to be improved, especially on the high stressed sections;

- The design concepts resulting from this research and the modified wagon frame that was analysed using FEM (see Figure 4) shall be validated through rig tests (see WP6 results);
- The innovative features proposed for the multi-purpose vehicle should be investigated in detail, according to the final manufacturing drawings; their implementation is feasible, but would require further detailed design work;
- The flooring solutions using recycled materials are very promising both in terms of lightweighting and sustainability; these solutions have a high TRL and would require more modelling and testing work to be implemented on a future prototype;
- It is recommended that the SUSTRAIL vehicle would implement some of the innovative components with respect to commonality and interoperability; this would enhance the vehicle sustainability by minimising the maintenance costs.

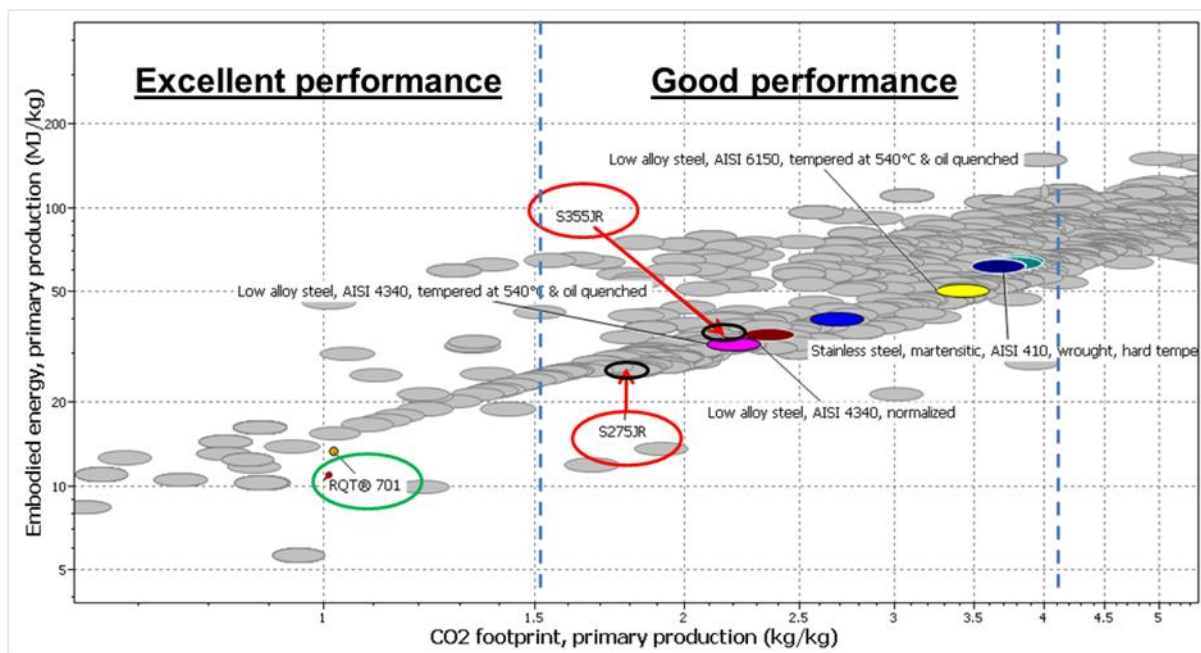

Figure 3: Analysis of Material Selection for the vehicle structure in terms of Embodied energy vs CO2 footprint

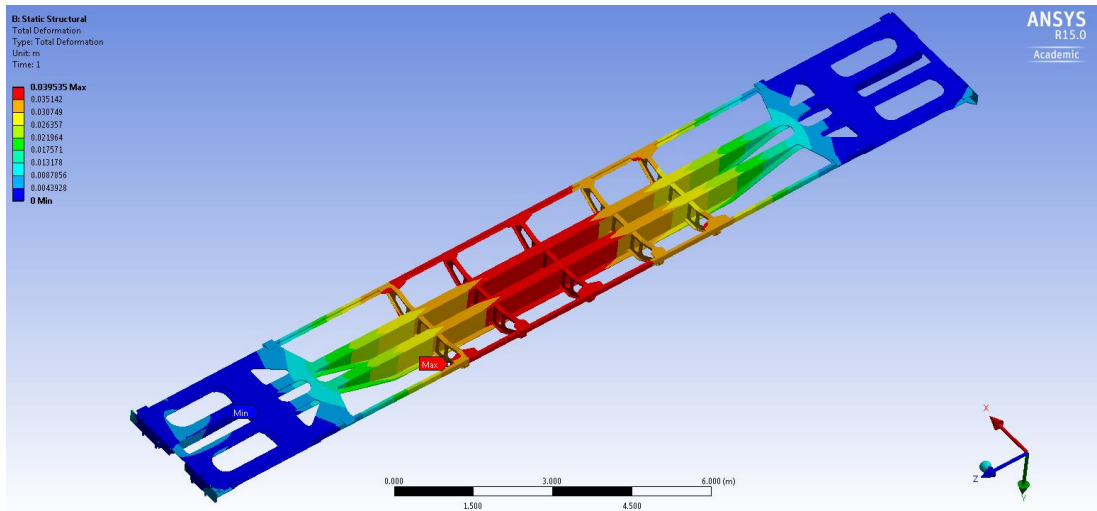

Figure 4: FEM analysis of the wagon frame (Total deformation under vertical and longitudinal service loads)

1.3.2.4 On-board sensors for freight wagon monitoring

Remote condition monitoring is becoming widespread in most branches of engineering. A wide range of sensors is available of monitoring the performance of components in all the different subsystems of a railway vehicle. Many of these were reviewed in the SUSTRAIL project and a number of possible systems were chosen for remote condition monitoring with the aim of meeting the overall project requirements of improved performance at greater reliability than the conventional vehicles currently in service.

In particular, On the SUSTRAIL bogie it was decided to implement an on-board monitoring system to measure the temperature of the 4 axle boxes plus the acceleration in 3 axes for each side of the bogie, as shown in the next figure:

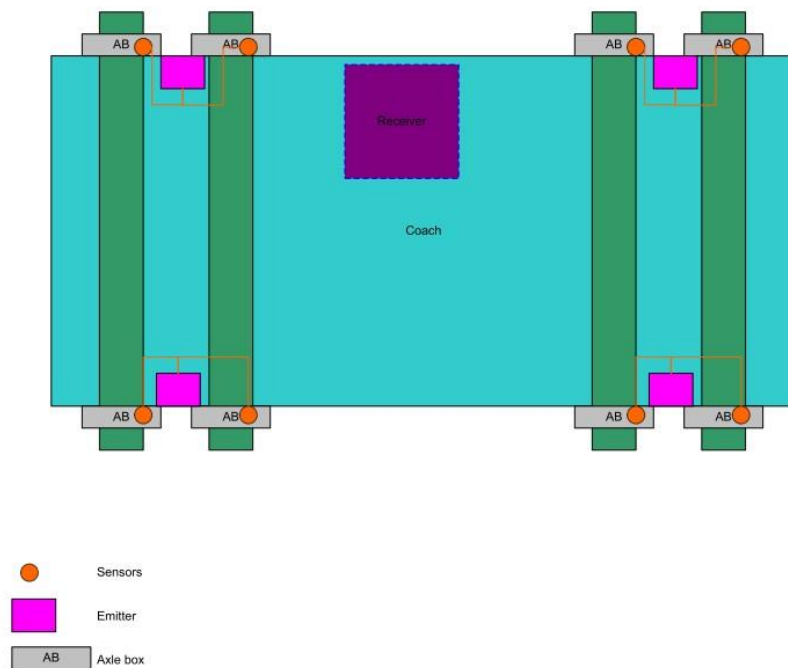

Figure 5: Schematics of SUSTRAIL Vehicle Measuring system

In addition to the monitoring of the bogie, The feasibility of two different systems for monitoring the integrity of railway axles for freight vehicles has been investigated. The first monitoring method, “Low Frequency Vibration” (LFV) is based on measuring the bending vibration of the axle and identifying some typical patterns in the waveform and spectrum of these signals to detect the presence of a crack propagating in the axle. The second method, “Acoustic Emission” (AE) is based on detecting low intensity elastic waves generated in the axle by the propagation of the crack.

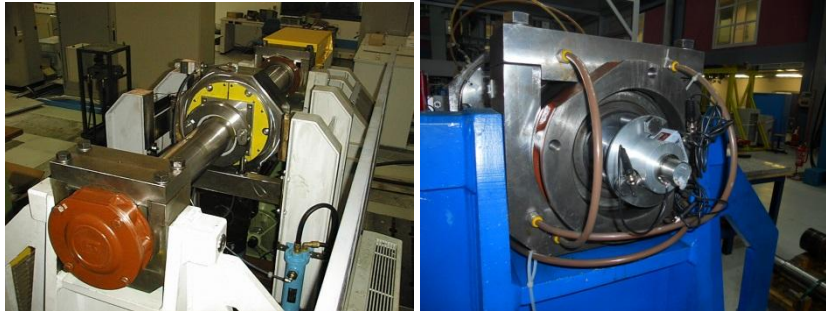

Figure 6: Experimental set-up for full-scale AE and LFV measurements

1.3.3 Infrastructure innovations

The specific aims of SUSTRAIL Workpackage 4 ‘Sustainable Track’ were to “*deal with the improvements needed to be developed on the track side for the railway infrastructure to accommodate more traffic whilst at the same time reducing deterioration of track and wheels through increasing the resistance of the track to the loads imposed on it by vehicles. This will assist in sustainable achievement of increased speed and capacity for freight traffic, thus contributing towards making rail freight more competitive.*”

There is a very strong coupling to the vehicle workpackage, ‘The freight train of the future’, since it is essential to undertake a systems approach to analyse the combined track and vehicle loads and associated deterioration. The output from WP4 also informed the decision-making for the Business Case workpackage to select the most promising infrastructure technologies for testing and demonstration. Sustainable Track was made up of five tasks:

- Task 4.1: Performance based design principles for resilient track: determine the factors that influence the resistance of track to the loads imposed, and how this can be improved
- Task 4.2: Supportive ballast and substrate: support conditions vital to maintaining track geometry
- Task 4.3: Optimised track systems and geometry: track geometry measures and intervention levels
- Task 4.4: Switches and Crossings: novel S&C component design building on the outputs from INNOTRACK
- Task 4.5: Track-based monitoring and limits for imposed loads: includes definition of Minimum Action Rules

The five tasks complemented each other to deliver new techniques, analysis and modelling tools to understand the challenges of the existing track and vehicle system and also to predict the impact of the proposed SUSTRAIL wagon developed in WP3. Note that maintenance and renewal costs of a typical railway, track and substructure represent 50 to 60% of the total costs, so track and substructure upgrades can achieve a significant impact on the overall costs of railways.

To identify incoming and futuristic innovations that could lead to a more resilient track, a structured approach was adopted in SUSTRAIL. Initially, a failure modes and effects analysis (FMEA) of the

infrastructure was carried out. The approach can be considered to be a “performance-based” approach: from the identification of failure modes and associated risks, the relevant SUSTRAIL innovations were identified in terms of their capacity to mitigate the severity and/or the occurrence of a failure event, or to increase the ability to detect precursors so avoiding failure. The FMEA provided a baseline for the reliability analysis of the track optimization process. In addition, this approach linked with “risk”, “vulnerability” “resilience” and “robustness” that were key criteria for SUSTRAIL.

FIC	Selected Innovations from IM NR + ADIF	Updated Performance and Cost					RCPI variation
		Severity (S)	Occurrence (O)	Detection (D)	Cost (C)	RCPI	Reduction (prior vs. after the introduction of the innovation)
R1	Ultrasonic monitoring and wheel impact detection (WID)	9	6	2	4	408	49.6%
R2	Premium rail steel Automated structure monitoring /inspection	9	6	4	3	567	55.0%
E1	Dynamic stiffness monitoring Laser scanning Ground penetrating radar	7	6	3	9	893	20.5%
E2	Moisture content monitoring	6	2	7	5	351	45.8%
E3	Cutting monitoring (e.g. movement sensors)	9	5	3	8	972	36.5%
T1	Specific geo-grids and under-sleeper pads	5	5	3	6	405	10.0%
S1	Automated structure monitoring/inspection	9	5	3	5	675	24.2%
SC	Improved rail material	7	5	2	4	234	10.9%
J1	Monitor dip angles for planned maintenance	8	4	3	4	280	-1.6%
RP	Improved life of pad	6	3	6	3	206	36.3%

Legend for RCPI variation:

High Impact: Extremely great improvement: The innovation should be investigated and implemented

Moderate Impact: Sensible improvement: It is worth considering implementing the innovation

Low Impact: Some of these innovations were assessed as they had been included in the SUSTRAIL description of work

Table 5: Selection of potential infrastructure innovations from IM perspective

1.3.3.1 Rail

Deliverable 4.1 (Performance Based Design Principles for Resilient Track) utilised performance based design principles and complementary monitoring tools to determine the factors that influence the resistance of track to the different loads imposed on it by trains, and the means by which this resistance could be improved.

Split into sub-tasks, this work considered both the track as part of a system (in conjunction with the other tasks) and its individual component parts e.g. rails, sleepers, and fastenings.

Typical loading on track components for selected critical running vehicle-track combinations has been defined for rail pad forces; ballast-sleeper interface stresses and sleeper bending stresses, and sleeper & rail accelerations. This has enabled mechanical component testing and modelling of rail joints to be undertaken, which has highlighted the impact of rail foot corrosion in this area and the stress concentrations in the joint components.

Minimum Action Rules have been developed for rail foot corrosion, considering rail types and corrosion levels, which has proven that the technique can be used to assist in planning inspection routines and defining the remedial action required following the detection of a defect. Three corrosion levels were modelled and results reported using un-randomised single model run data to provide exact figures. The work highlighted that corrosion of even 0.5mm all around the foot has a significant influence on the lifetime before failure and higher levels of corrosion show even more severe reductions. The 60E2 rail profile shows more resistance to corrosion over 56E1 profile due to the increased cross sectional area.

Risk analysis has been undertaken to demonstrate the benefits for Infrastructure Managers to visualise systems and components performance and subsequent interventions to deliver a high performing track. This includes estimations for both system and component failure frequencies and the consequences of failure.

Moving from reactive maintenance, based upon safety limits, to **predictive maintenance** limits has been considered using decision support tools and maintenance strategies to determine the most cost effective points to undertake maintenance activities. This work has included track geometry, contractor performance and tamping and has identified cost effective intervention limits.

1.3.3.2 Switches and Crossings

Task 4.4 of SUSTRAIL focused on optimising the operation, safety and the reliability of switches and crossings (S&C). The work began with a technology review, followed by data analysis, model development, simulation and physical testing. The areas considered were:

- Point operating equipment (POE), **drive and lock mechanisms**
- The use of **advanced rail materials**
- Testing of **lubricants** for slide chairs
- The geometrical **interface between wheel and crossing**
- Optimisation of the **support stiffness** in the area of the crossing panel

The main outcome of the project in the area of **drive and locking devices** includes a thorough review of the INNOTRACK recommendations in the context of the SUSTRAIL freight corridors and supported by a failure analysis specific to those selected freight routes in the UK. Conclusions converge towards the INNOTRACK recommendation that the current state-of-the-art physical arrangement for Switch and Crossing (S&C) drive and locking device is to have combined drive, locking and detection devices integrated into hollow bearers at the main drive locations. This arrangement permits access to the ballast bays between bearers for mechanical tamping, which allows for a consistent support conditions to be maintained throughout the S&C unit and adjoining track which reduces dynamic loads and degradation. Therefore it is recommended that the design specifications for the physical arrangement, modular design, standardised components and interface protocols developed by the INNOTRACK should be adopted with condition monitoring of both, the drive, locking, and detection device itself, and the parameters of the S&C unit which it can measure. It is anticipated that the adoption of these design specifications with condition monitoring would increase in the maintainability of the S&C unit and component life, improve reliability through fault detection and prediction, enable the adoption of efficient condition based preventative maintenance

strategies and eliminate the majority of the types of failures associated with traditional mechanical linkages. These have been found to be the most common type of failure in the fault and failure data from the case study route.

In the area of **advance materials** the main output is strong evidence of the benefit offered by premium grades of steel to combat the degradation observed on switch blades over their lifetime. R350HT has demonstrated a high resistance to wear in comparison to R260 grade rail. HP335 has demonstrated both excellent wear resistance and RCF resistance in a switch blade application. Bainitic grade BLF320 showed excellent RCF resistance in switch blades however the wear resistance is similar to that of a pearlitic rail of similar hardness. A second area of further work is into applications of premium steels into other parts of the crossing such as wing rails and the crossing nose. Moreover further work is still required to understand the degradation mechanisms. Full understanding of the degradation mechanisms of premium rail steel in these applications and also repair in service is needed to allow correct material selection. Furthermore methods of testing of various **lubricants** for slide baseplates have been developed and used to determine those lubricants that performed best under conditions proposed by Network Rail. Significant immediate and the long term benefits have been demonstrated from the use of advance lubricant with respect to dry condition and conventional options.

The main outcome of the project in the area of **geometrical interface between wheel and rails** has been to further the understanding of the impact of vehicle and wheel shapes on the vertical damage at crossing panels. The tasks has produced advance simulation algorithms and techniques capable of handling large set of vehicle and track conditions to help identify those properties in the system leading to disproportionate damage. For example particular shapes of wheels (e.g. increased conicity) have been shown to lead to increased vertical force impact and limit values can thus be proposed as well as automated control techniques can be envisaged in the future based on these results. This work will be extended in future European projects such as the on-going Capacity4Rail to suggest optimised wheel and rail shapes and improved support solutions.

The main outcome of the project in the area of **support stiffness optimisation** has shown through numerical simulation that the vertical damage in the area of the crossing panel can be improved under a wide range of track support condition by the addition of resilient layers. The most effective methods investigated are showing that the use of under sleeper pads can be very effective in limiting the vertical forces transmitted to the track component and the supporting layers. Furthermore they are showing the advantage of being very effective at lowering and equalising stresses in the foot of cast crossings and also reducing significantly the differential stresses on the supporting ballast layers.

1.3.3.3 Substructure

The objective of Workpackage 4.2 was to identify the impacts of substrate stiffness variation on track geometry deterioration and other track defects such as the effect of vertical plane long wavelength rail bending on rolling contact fatigue crack growth. The activities focused on the role of structures such as bridges and embankments, and track substrate stiffness, in enabling the railway to effectively bear the loads to which it is subjected.

The infrastructure managers (IM) provided detailed site data for use in analyses and described current desk-based and on-site investigations used to assess the adequacy of trackbed stiffness. The on-site investigations can be intrusive (digging trial pits) or use a Falling Weight Deflectometer to assess stiffness and critical speed. It was reported that up to about four times the depth of granular trackbed layer (maybe a metre) can be required to produce the same dynamic sleeper support stiffness when running over well-drained soft clay compared to very stiff ground. If good drainage is not available the expected stiffness will approximately be halved.

IM consider that a stiff trackbed results in better track quality needing less maintenance, resulting in lower whole life cost. Whilst a stiff track bed results in higher ballast loading, it is clear that this is within acceptable limits and other benefits from reduced ballast movement results in less ballast deterioration and therefore increased durability. Very low trackbed stiffness can result in trains approaching the “critical velocity” when they travel at the same speed as the displacement wave they generate in the substructure. Unless speed restrictions are introduced this results in rapid deterioration of track geometry.

From the data provided by the IMs, a specific section of the Bulgarian line which runs between Serbia and Turkey was modelled. Data regarding the condition of the track for this site suggests the track is in a bad condition. An analysis was carried out of a laden vehicle, moving at 120 km/h over the site. The equivalent stresses in the different layers after 2.1 seconds of simulation are shown in Figure 7. These pictures clearly show the footpath of the train wheels in the structure and the propagation and extension of the stress field in the soil layers. Indeed for a soft soil in the subgrade evidence of the stress induced by the train is quite significant.

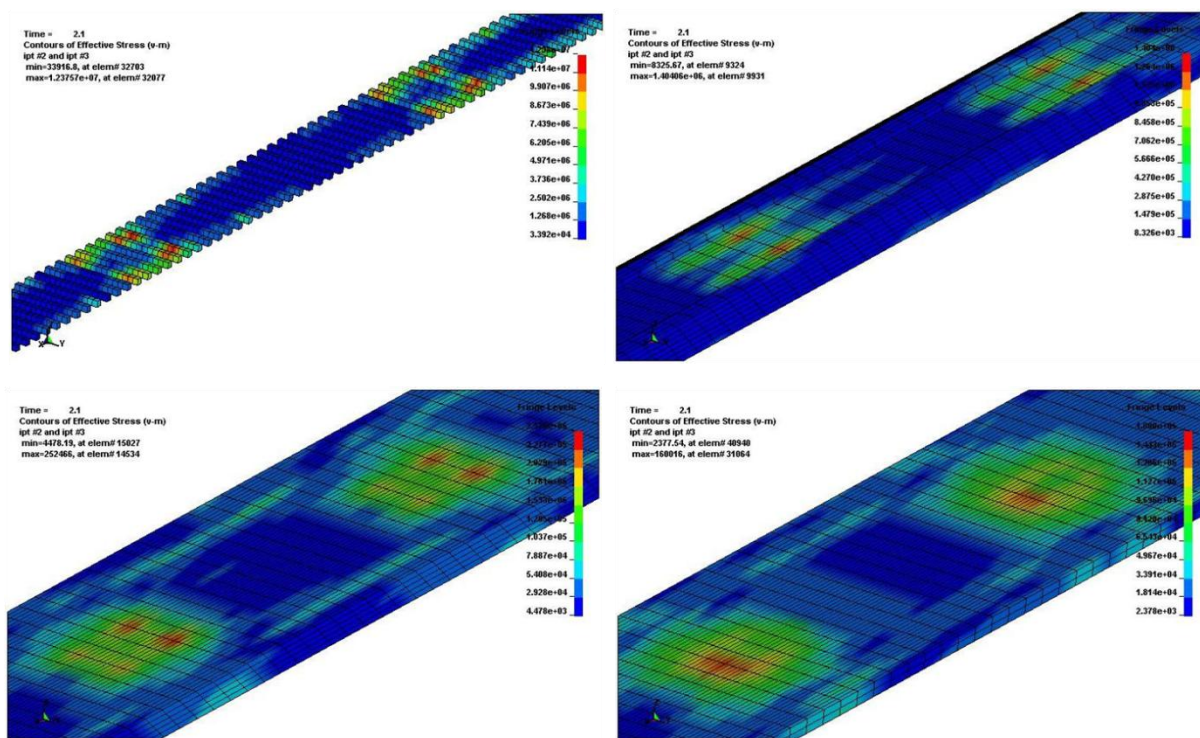

Figure 7: Dynamic FEM analysis of railway substructure showing the contours of effective stress in the different layers: sleepers (top left); ballast (top right); sub-ballast (bottom left) and substrate (bottom right)

A tool, illustrated in Figure 8, was developed to enable the effect of varying track stiffness to be assessed. Differential stiffness of sleeper locations was included to model the different force required to lift a sleeper compared to that to push it into the ballast.

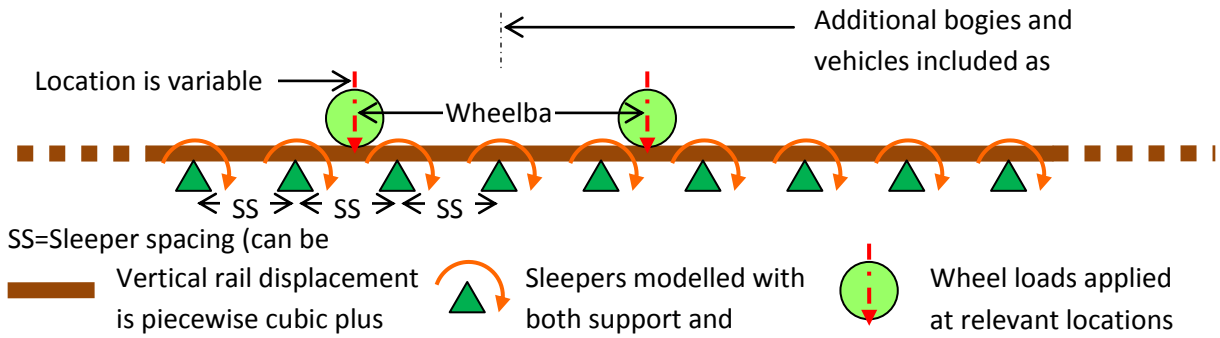

Figure 8: Beam model of rail

The model was used to assess various scenarios of loose and voided sleepers. Figure 9 illustrates a set of results; the displacements and rail bending moments are shown for a vehicle partway onto a transition to a stiff foundation (e.g. onto a bridge). The solid green curves show the results for a uniform foundation. The transition is achieved by doubling the stiffness of only one sleeper (to 100kN/mm) and has resulted in the increase in bending moment halving compared to there being an abrupt transition. It is also evident from Figure 9 that for each downward bending moment associated with a wheel load there are upward bending moments in the adjacent sleeper bay; the largest of these for this scenario occurs between vehicles, where there is the shortest distance between wheels, and has a magnitude about half that of the downward bending moment.

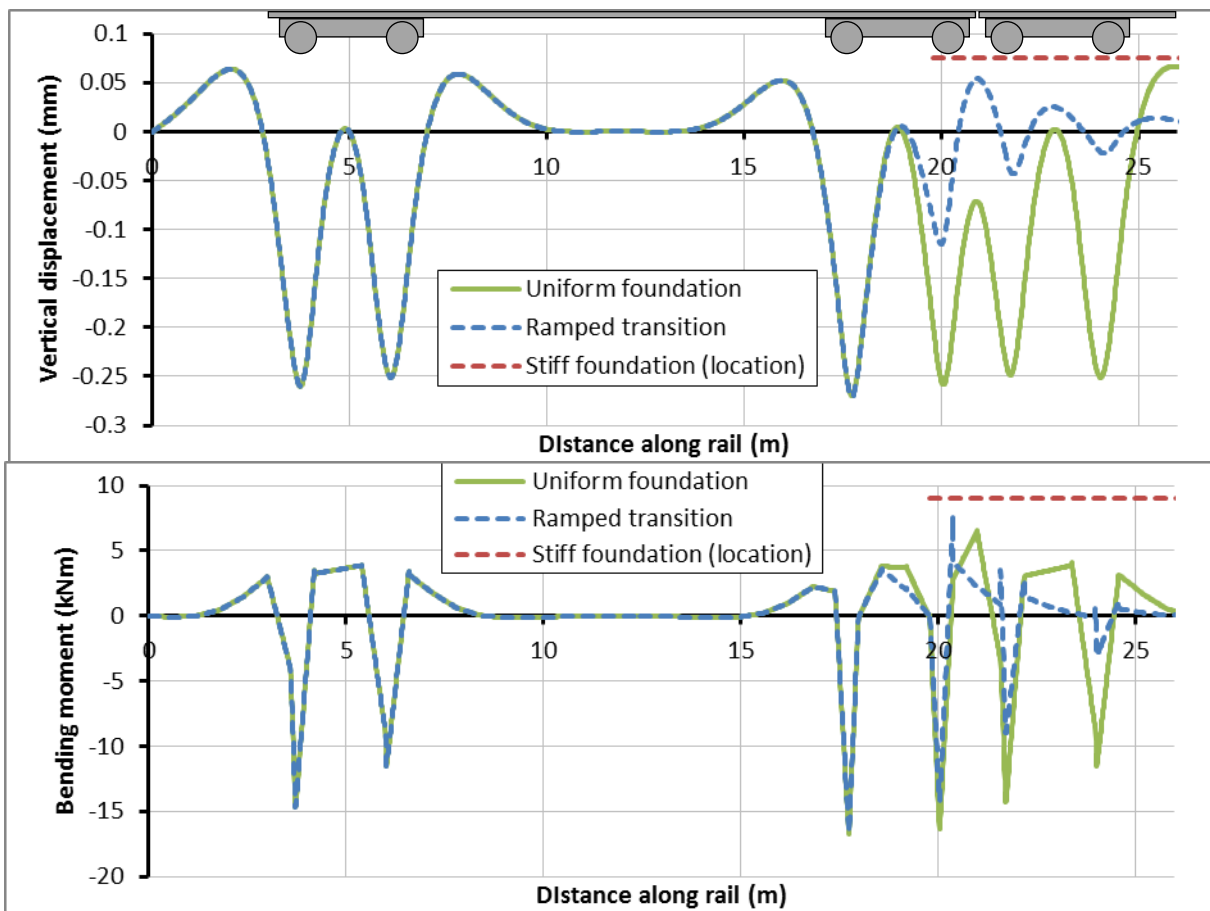

Figure 9: Vehicle passing over ramped transition to stiff support

1.3.3.4 Wayside condition monitoring

The objective of Workpackage 4.5 was to identify monitoring tools to increase the lower bound of the track resistance probability curve through removing the causes of track failures at discrete locations with low damage resistance. The work included an identification of technologies that can be used to monitor infrastructure and vehicles to optimise preventative and intervention-level maintenance strategies. There are several different technologies used to measure loads imposed by vehicles on the railway infrastructure, different implementations of them, and the intervention levels and action requirements applied vary from one member state to another.

The use of axle load checkpoints (ALC) can be motivated by different aims and so be operated in different ways. For infrastructure managers, the aims could be the protection of infrastructure from high loads, or potentially dangerous vehicles (for example those with a high potential for derailment), the loading on the infrastructure imposed by running vehicles, or local degradation of the infrastructure.

SUSTRAIL exploited the availability of a wayside monitoring station installed on the Swedish iron ore line Malmbanan through the partner DAMILL. The data provided is used to suggest maintenance alarm limits for different parameters that are related to different vehicle defects. Maintenance alarm limits are triggered earlier than safety alarms limits and do not require such precise measurements (under normal degradation rates there is time to measure the same vehicle several times before deciding on the action to be taken). They are supposed to identify an optimal time, based on economics, when it is advisable to bring vehicles into a workshop instead of leaving them to degrade (and potentially damage track) further.

1.3.4 Business Case

SUSTRAIL Workpackage 5 ‘Business Case’ was linked to the vehicle (WP3) and track (WP4) workpackages whose main results were presented above. The specific aims were to “*consider the economic business case and implementation issues associated with the vehicle and track options developed in WP3 and WP4 respectively. Amongst other aspects, the Workpackage will act as both an iterative filter for the options developed in WP3 and WP4 in order to help focus the engineering development to those options which are likely to have greatest overall net benefits, as well as providing a final business case appraisal for the preferred option.*”

The SUSTRAIL project is more than technical innovations. At all stages within the project there has been involvement of disciplines such as economics, and human factor analysts, and substantial stakeholder engagement. This is important to ensure that the engineering research is directed at areas which best meet the overall objective of the project, namely to improve the competitiveness of rail freight. The Business Case workpackage contributes to the overall project objective by

- helping to prioritise innovations for final assessment
- aiding the project to identify means to integrate the engineering innovations into the industry, including phasing in of novel technologies
- developing strategies for the equitable redistribution of whole-system savings
- helping promote and facilitate industry, government, and other stakeholders’ ‘buy-in’

To this end, work to understand what is needed by the rail freight industry (in terms of technical innovations in the vehicle and track) to meet the overall policy objective of increasing the market share of rail freight, was embedded within the early stages of the SUSTRAIL project; in order to meet its objectives, the engineering research had to align and be optimised to this end.

Figure 10 presents the interaction of the Business Case development with the rest of the project.

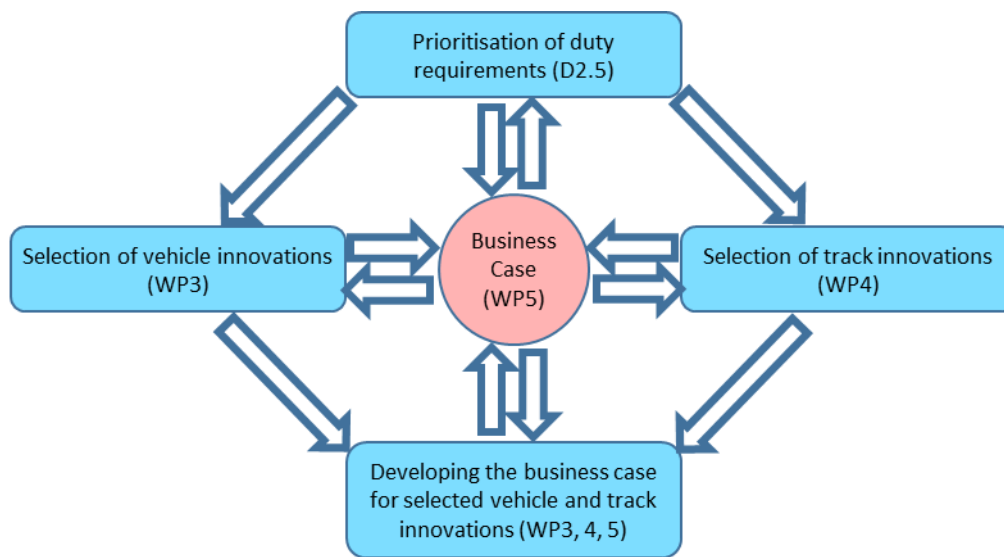

Figure 10: Integration of the Business Case within the project

1.3.4.1 RAMS and Life Cycle Costing (LCC)

Central to the SUSTRAIL Business Case is the impact on stakeholders in the industry, including the infrastructure managers (IMs), freight and passenger operators, and the end users whose freight is being moved. It needs to be demonstrated that for these stakeholders the benefits of the SUSTRAIL innovations outweigh the costs. Therefore the Business Case includes a cost-benefit analysis comprising:

- financial analysis of the impact on IMs train operators, end users, and government, in terms of net present value (NPV) and internal rate of return (IRR)
- a socio-economic cost-benefit analysis covering all parties, in terms of NPV, IRR, and benefit: cost ratio (BCR)

RAMS and LCC models were developed to assess the innovations from a holistic approach that aimed to reflect how the track and the wagon systems interact. In the model, maintenance actions on the track were affected by the more track-friendly SUSTRAIL wagon having been introduced. The economic benefits for the Infrastructural Manager (IM) can be quantified by considering the results of vehicle simulations. Effects in the opposite direction, how the track will affect the wagon, have not been implemented in the model due to lack of data.

For the development of the **RAMS** for SUSTRAIL we have used a simulation implementing a combination of some of the techniques mentioned in EN 50126. The states of the wagon and track system are monitored using stochastic simulation of failure events. The model is developed using an event-driven simulation tool called SIMLOX that enables detailed analyses of the variation of technical system RAMS performance over time given different operational and logistics support situations. During the simulation, operations generate failure events, which in turn create a need for maintenance personnel, actions, and other resources. The flowchart of the RAMS simulation is shown in Figure 4.4. The first stage is the simplification and characterization of the track section and wagon. This involves a description of the technical system breakdown structure and extraction of design features relevant to the RAMS study.

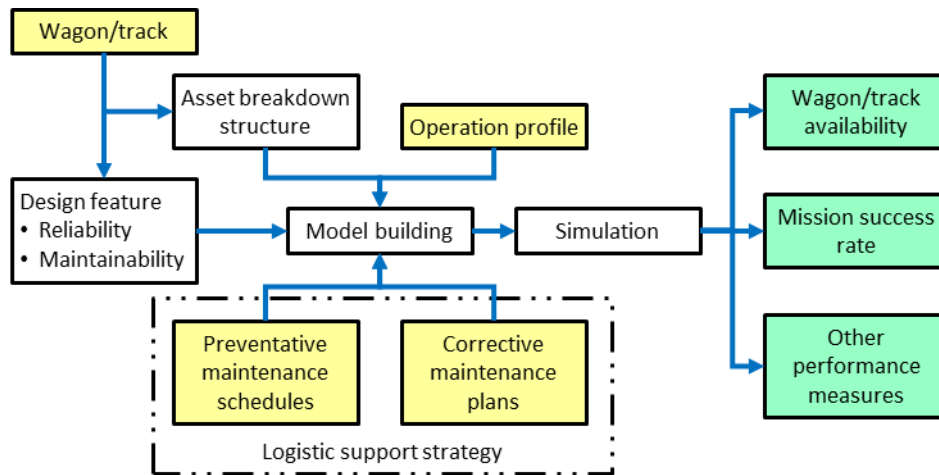

Figure 11: Description for RAMS simulation approach

The first stage is the simplification and characterization of the track section and wagon. This involves a description of the technical system breakdown structure and extraction of design features relevant to the RAMS study.

The second stage is the model building, where models are developed to describe the stochastic failure process and logistic support plan for the system. The maintenance strategy and logistics support plan for wagon and track system include preventive (PM) and corrective maintenance (CM or repair). The PM and inspection schedules were based on standard practices and expert information for both wagon and track systems. The preventive replacement of wagon components was based on the recommended interval/lifespan and are carried out when the wagon is in the workshop for inspection or CM. The failure characteristics of the benchmark wagon and track systems were obtained from relevant historical records of maintenance service providers, while the failure characteristics of the proposed SUSTRAIL design were based on expert judgment. In the model, failure events are generated using a stochastic process based on the estimated failure rate for each failure mode.

The third major input into the model is anticipated train mission profile or traffic schedule on the line. The operation profile of the wagon and traffic on the route were specified in the format required by the simulated tool.

The result of the RAMS simulation for the SUSTRAIL vehicle was that the technical performance of the SUSTRAIL wagon was better than that of the benchmark wagon. The estimated availability of the benchmark wagon was about 95% while that of the SUSTRAIL wagon was estimated to be 99%. The main factor responsible for the lower availability of the benchmark wagon was the logistic and waiting time at the workshop. In addition, the mission success rate of both the SUSTRAIL and benchmark wagons was similar. From the cost perspective, although the initial cost of acquisition of the improved wagon was approximately 75% higher, the reduced cost of maintenance and failure pays off in the long run. It is estimated that for the curves on the simulated UK route the improved wagon alone will give at least a **5% reduction in the life cycle cost over 30 years**.

Life-cycle costing can be described as the economic analysis process carried out to assess the total cost of acquisition, ownership (operation and maintenance), and disposal of a simple or complex system. It is either applied to the entire life-cycle of a product, or one life-cycle phase, or combinations of different phases. The basic aim of a LCC analysis is to provide support for decision making in any or all phases of a system's life-cycle. An important objective in the development of LCC models is to identify costs drivers, i.e. those cost elements that have a major impact on the

LCC. In relation to the SUSTRAIL project, the LCC analysis was carried out to support decisions for some of the innovations suggested by the project towards a sustainable railway vehicle and track.

For the wagon and track LCC model, all the cost elements were categorised into four aggregate groups:

- Life acquisition cost (investment and renewal for track)
- Life operation cost
- Life support cost (maintenance cost for track)
- Life termination cost

In the cost benefit analysis work the costs were aggregated to the case study route levels. This stage applies the LCC to the entire route cost structure rather than the partial structure. As an indication of magnitude, for the UK route, the **LCC saving from the track improvement is of the order of 9%** although this route has a relatively high curved track length. If the track uses premium rail steel together with the improved wagon there would be approximately a 61% reduction in the LCC. In the ‘track improvement with speed change’ scenario, the expert assessment was that the reduction in LCC would be approximately 43%.

1.3.4.2 Track Access Charges

A key economic interface between infrastructure managers and freight operators is the track access charge regime: payments by train operators to infrastructure managers for the incremental costs associated with running the train service. Access charges are the key mechanism by which infrastructure cost improvements are passed through to freight operators and, in turn, to freight users. Similarly, suitable discounts in track access charges for different vehicle types can incentivise the adoption of track friendly vehicles. This is an important incentive given that track friendly vehicles may imply higher capital costs for operators. To build a financial case for operators to adopt these vehicles, reductions in on-going costs need to be present and access charges are such a cost (they are incurred whenever the vehicle is used).

In SUSTRAIL new empirical research has been undertaken to understand how costs (and not just damage) vary with traffic of different types. The research within SUSTRAIL on access charges has advanced the understanding of railway infrastructure marginal costs associated with railway traffic and also researched how implementing price incentives (via differentiated access charges) has influenced operator behaviour. New work has been undertaken in integrating the two main approaches (engineering and econometric) to analysing the direct cost to the infrastructure manager associated with running additional traffic. Further new work has been undertaken to understand renewals costs and traffic disaggregation in the econometric approach.

Following the LCC analysis and bespoke engineering damage simulation of the vehicle on the track undertaken in SUSTRAIL WP3, the access charge reductions (relative to the base vehicle(s)) were those shown in Table 6.

	SUSTRAIL 0 – vehicle improvement	SUSTRAIL 1 – vehicle and track improvement	SUSTRAIL 2 – vehicle track and speed improvement
Vehicles within the SUSTRAIL vehicle class	10.4%	17.4%	15.2%
Other vehicles	0%	6.9%	4.8%

Table 6: Access charge reduction from base in each of the scenarios

Note that the SUSTRAIL vehicle requires a discount because it does less damage to the track than the base vehicle.

1.3.4.3 Qualitative assessment of the social cost benefit analysis

Overall the social cost benefit analysis shows a positive benefit to all groups considered under each of the three SUSTRAIL scenarios: that is the infrastructure managers, the freight operators, freight users, 3rd party beneficiaries of environmental improvements, and government. Further, because there are overall cost savings, the traditional benefit to cost ratio for the improvements is negative, indicating that these innovations have a positive impact on society on a cost case, even before any user and environmental benefits are factored in. This is a strong result. The emerging modelling indicates that it could lead to a 10% increase in the rail freight market for container traffic in the UK (SUSTRAIL 1 scenario).

Table 7 summarises the key impact groups and how the SUSTRAIL innovations impact them. The trends are clear, but the magnitude of the benefits will depend on the exact scenario considered. However, the conclusion from the cost benefit analysis is that **there is a strong social case for the innovations.**





User group	Description	Net benefit
Infrastructure manager	Reduced LCC from either: <ul style="list-style-type: none"> Track innovation Less track damage from track-friendly vehicle 	
Operator	1) Reduced LCC for vehicle 2) Reduced track access charges for vehicle from either: <ul style="list-style-type: none"> Track innovation Less track damage from track-friendly vehicle 	
Freight users	Better freight service resulting from: <ul style="list-style-type: none"> Improved price ((eventual) pass through of operator cost savings due to competitive market forces in freight market) Improved reliability Improved speed of service (SUSTRAIL 2 only) 	
Environment	Reduction in CO ₂ resulting from the modal shift of freight from road to rail Reduction in noise	
Government	Reduced subsidy to the railway due to reduction in LCC of the infrastructure manager	

Table 7: Summary of the Social Cost Benefit Analysis

1.3.5 Demonstration and Validation

The aims of Workpackage 6 ‘Technology Demonstration’ were to “*validate a selection of the infrastructure and vehicle component upgrade solutions and technologies developed in the project ... to provide information for the analysis of the potential improvements in terms of system reliability (damage and failures, maintenance costs, etc.) and system performance and capabilities (speed, load, etc.).*”

The workpackage included building a vehicle incorporating the SUSTRAIL innovations and designing and undertaking appropriate tests at the Faurei test track in Romania. Demonstration of most infrastructure innovations took place on other infrastructure during the project.

1.3.5.1 Vehicle upgrades for SUSTRAIL demonstration

The SUSTRAIL prototype vehicle includes the innovations which were developed and analysed within Workpackage 3. The upgrades were designed or adapted from similar solutions and integrated into the flexible design of the high capacity freight wagon.

The SUSTRAIL **prototype bogie** includes the following upgrades:

- Double Lenoir links
- Longitudinal arms
- Wheelsets with coated axle and disc brakes



Figure 12: Lateral view showing the double Lenoir links

Figure 13: Coated axles with disc brakes and brake callipers installed on the bogie frame

1.3.5.2 Infrastructure upgrades for SUSTRAIL demonstration

Amongst the innovations considered within Workpackage 4: ‘Sustainable Track’, four have been tested on mainline infrastructure:

- Premium Rail has been used in several trial sites in the UK on specific curves to address wear and Rolling Contact Fatigue issues and has been found to offer increased rail life and reduced grinding and inspection requirements
- Earthwork-stabilising geotextiles with inbuilt monitoring sensors have been used on an embankment in Germany
- Under-sleeper pads have been assessed following installation on UK mainline track

- Trackside monitoring of vehicles and infrastructure has been undertaken on a line in Sweden to identify wheel loading and defect issues

Additionally, the rapid application sensor developed by NewRail is to be tested at the test track.

1.3.5.3 Vehicle Laboratory Tests

- *Dimensional tests*

Objective: to verify that the outside dimensions of the vehicle, and any clearances and flexible connections when completely assembled and in working order, comply with the limits set out in the standards.

- *Construction gauge of the wagon test*

Objective: to verify that the kinematic envelope of the wagon is in accordance with the design, by the coefficient of flexibility (sway) test.

The coefficient of flexibility (s) is the relationship between the lateral inclination of the loaded wagon (η) on its suspension springs as a result of a lateral inclination of the track (δ).

$$s = \tan\eta/\tan\delta$$

- *Weighing tests*

Objective: to verify that the vehicle mass and distribution comply with the limits set out by the manufacturer and includes tests for the following parameters: the vehicle mass, the measured load per axle, the measured load per wheel

- *Friction brake system tests*

Objective: to verify that the brake system operates in accordance with the freight wagon design and give sufficient confidence that the dynamic tests may take place. The following systems shall be functionally checked statically: emergency brake, service brake, mobility of brake rigging

- *Parking brake system tests*

Objective: to verify that the parking brake system satisfies the requirements of the manufacturer.

The test criteria to demonstrate the effectiveness of the wagon parking brake system involves the vehicle remaining stationary for a limited period, held by a parking brake subject to leaks (e.g., hydraulic or air brake); the brake shall be applied with maximum force and it shall be verified during a period specified, that there is no significant fall-off in the force applied.

1.3.5.4 Vehicle Field tests

- *Dynamic structural analysis of the vehicle*

The test is to demonstrate the compliance with Wöhler curve of the wagon body.

- *Braking and braking thermal capacity tests:*

A single vehicle “slip brake test” will be performed. The test will be carried out at the following speeds: 100 km/h, 120 km/h, 140 km/h

The objective of the test is to determine the braked weight percentage, by means of the average stopping distance.

After each braking test, **the thermal capacity** of the wheels and brake discs need to be determined.

- ***Evaluation of the running behaviour of the vehicle by measuring accelerations***

In these tests running safety, and ride characteristics of the vehicle are evaluated.

Running safety

- accelerations at the bogie allow an assessment of running safety on a simplified basis
- accelerations in the vehicle body are used for the simplified assessment of running safety
- instability of the vehicle is assessed on the basis of a moving RMS value of lateral accelerations on axles

Ride characteristics

- accelerations in the vehicle body are used for assessing ride characteristics of the vehicle; the assessment includes maximum and RMS values of accelerations
- ***Noise tests***

Noise emitted by freight wagons can be either pass-by noise or stationary noise. *Stationary noise* of a freight wagon will only be of relevance if the wagon is equipped with auxiliary devices like engines, generators, or cooling systems, so is not applicable for the SUSTRAIL wagon.

Pass-by noise: the objective of the test is to determine the A-weighted equivalent continuous sound level.

1.3.5.5 Infrastructure tests

The infrastructure tests were performed to demonstrate that the innovations provide the anticipated improvements to track resilience or suitable monitoring outputs. The following innovations have been used trackside in the UK, Sweden and Germany to validate their performance and therefore have not been included in the trials to be undertaken at the AFER Railway Testing Centre Faurei, Romania.

- **Testing of Premium Rail**

HP335 has been intensively monitored at eight trial sites across the United Kingdom. Seven of those sites were in Network Rail Infrastructure, and one on a light rail system. All trial sites were chosen by the customer based on their previous degradation history and have been monitored in collaboration with the customer at regular intervals for up to four years for wear, rolling contact fatigue, corrugation, and weld performance. All trial sites have seen positive results compared to previous standard grade rails. Following these trials the grade was fully approved for use on Network Rail infrastructure and as of March 2015 over 600 km of HP335 rail has been supplied for installation within the United Kingdom. HP335 is designed to be used on curved track and other high duty areas where rolling contact fatigue and wear are the relevant degradation mechanisms.

- **Rapid application sensors as a tool for infrastructure managers for track condition monitoring and assessment**

A compact and portable rapid application sensor system has been developed by partner NewRail to utilise advances in micro-processing, wireless and battery technologies to develop a system which can be applied rapidly. This allows the system to be installed between service trains and deployed almost anywhere on the network. The ability of the system to be rapidly installed without disrupting service trains and its independence from the power infrastructure make it an effective tool not only for collecting data on new track constructions or for model validation, but also as a site investigation tool to assess the performance of track and assist in identifying and resolving issues on sites were

problems have been identified. The prototype system comprises a combination accelerometer, gyroscope, and magnetometer sensor stick, which measures each of these parameters in three axis, connected to a processor with storage memory programed to record the output from the sensor. In addition to these components there is a small battery pack to power the system and a wireless connection module to allow the system to be set up, measurements to be initiated and stopped, and the data downloaded without the operator being at immediate risk from passing vehicles. The system could be adapted to measure other parameters by substituting different sensors and re-programming the system.

- **Sensor-integrated geotextile system**

Sensor-integrated geotextiles have been developed by partner D'Appolonia and have been considered within SUSTRAIL as a way of performing Structural Health Monitoring (SHM) of the railway infrastructure. In addition to the usual functions geotextiles perform (strengthening, filtration, stabilisation, separation, drainage) these geotextiles can undertake SHM as the result of the integration within the structure of distributed fibre-optic sensors. An efficient signal processing technique is used to process the raw sensor measurements to estimate damage size and location.

The benefits of using sensor-integrated geotextiles within the railway substructure include: Indicate impending failure, Evaluate critical design assumptions, Assess contractor's means and methods , so control construction, Minimize damage to adjacent structures, Provide data to help select remedial methods to fix problems, Document performance for assessing damages, Inform stakeholders, Satisfy regulators, Reduce litigation, Advance state-of-knowledge.

A field test was performed near Chemnitz (Germany), on a route having a very high traffic volume. The portion of the embankment was more than 100 years old and has been selected since it was under reconstruction. Periodic measurements have been carried out in order to detect any movement within the embankment and its evolution during time.

1.4 Project Impact including dissemination and exploitation activities

1.4.1 Dissemination

Dissemination of project was carried out addressing different stakeholders groups and potential end users of the project results.

Linking with other EU freight-related or similar research projects was carried out to allow cross-fertilization and mutual enrichment of projects, in particular with projects MARATHON and SPECTRUM, with SUSTRAIL presentations given at workshops of the two projects. Links with projects D-Rail, RETRACK, Twin Hub were also established.

During the course of the project, presentations were given within UIC Freight Forum where the main stakeholders of the rail freight system are represented.

UNIFE presented the SUSTRAIL project during the INNOTRANS 2012 and 2014 events. INNOTRANS is the biggest Rail Infrastructure event in Europe which takes place every two years. The events were attended by the supply industries and European (and International) railway Infrastructure Managers and Operators and were therefore an ideal forum to link end users with the technologies and results. Presentations of the SUSTRAIL project were given at the UIC stand at INNOTRANS and videos of those presentations were recorded for further dissemination. Setting apart its role of work stream leader in the Dissemination of the project, UIC is a target of major importance owing to the very wide membership of international railways. The different working groups and specialized forums and platforms (infrastructure, rolling stock, and freight) were regularly informed on the project results and will help in their future implementation.

In order to reach the staff at operational level, dissemination workshops were organised to present the SUSTRAIL results and their possible impact on 15 April 2015 in Milton Keynes (UK) and in Madrid on 28 April 2015. A final public Workshop was organised in Bruxelles on the 21st of May 2014. Overall more than 150 people attended the three workshops from representatives of important stakeholders representative of the railway freight system.



Figure 14 Graphical elements prepared for the three SUSTRAIL final workshops organised in Spain, UK and Belgium

UNIFE is a European association that represents the interests of the railway supply industry in Europe at the level of both European and international institutions. Its membership comprises manufacturers and integrators of railway rolling stock, subsystems, components, signalling equipment and infrastructure. UNIFE participated actively in dissemination, exploitation and training activities. Its particular focus was dissemination and exploitation where, through its committees, technical forums, and events it provided input from and result access to the rail industries, including maintenance contractors and suppliers. Further, it will continue distributing SUSTRAIL material at its annual and joint research events throughout the year. UNIFE is in close association with the national industry associations also a point of dissemination to the industries outside of the project.

1.4.2 Dissemination Media

1.4.2.1 Project deliverables

SUSTRAIL generated around 39 deliverable reports exclusively distributed to the European Commission and to the Partners of the Consortium. About 35 of these deliverables are technical reports and present the results of the project. Many of those deliverables have a public status for dissemination: some deliverables have been changed from status “Confidential” to “Public” as agreed during one of the meeting of the General Assembly, in order to increase the visibility of the project results and reach the interested stakeholders. Public deliverables are available from the SUSTRAIL web page.

1.4.2.2 Concluding technical report

Through the grant agreement with the European Commission, SUSTRAIL is committed to disseminating the project results. Therefore the Concluding Technical Report (CTR) has been drafted so as to be most complete document on the results of the project and on the methods used, the way the results are to be implemented, the identified technical problems and the proposed solutions. Available as hard copies as well as on the public website, it will be the “key” for reaching and using the SUSTRAIL results and it will summarize the content of all the project technical deliverables.

1.4.2.3 Top Management Summary report

Designed to be delivered via UIC Forums and Platforms and UNIFE high level committees to the top management (Infrastructure, Freight, Asset Management and Industry), this document based on the executive summary of the CTR will explain what SUSTRAIL has achieved and which effects can be expected – also in terms of costs – from the implementation of these results.

1.4.2.4 Flyers

A project flyer has been produced at the beginning of the project, where the list of partners, the project objectives, the structure, the targeted innovation and expected benefits are presented.

The updated project flyer has been produced at the end of the project. It gives a visual and quick overview of the results and their benefits. The purpose of flyers is to draw attention to the project results and refer interested parties to the more comprehensive documents: Concluding Technical Report, Top Management Report, Guidelines and Deliverables. Flyers were distributed not only at the main project meetings, but also on each occasion the project was presented to the interested audience: seminars, workshops, conferences, exhibitions (TRA 2014, Innotrans 2012 and 2014).

Sustrail: The sustainable freight railway. Designing the freight vehicle – track system for higher delivered tonnage with improved availability at reduced cost.

COORDINATED BY: CONCERTO TRAIN

TECHNICAL LEADER: NetworkRail

PARTNERS: odif, CAFER, DAMM AB, ECOPLAN, Gruppo CLAS, University of Huddersfield, NES, UTA, LUCCHINI, MARLO, memtec, newrail, NSK, UNIFE, SIRV, TATA, TU, unife, University of Twente, University of Warwick, University of Bath, University of Southampton.

PROJECT IN A NUTSHELL
 Sustrail is a European R&D project co-funded by the European Commission under FP7. Sustrail aims to contribute to a new era in the rail freight sector by adopting a holistic approach for a cost saved improvement in both freight vehicles and track components. Sustrail started in June 2011 with a duration of four years and with an EU funding of 5.6 M€.

PROJECT OBJECTIVES
 Sustrail addresses a cost based improvement in both freight vehicles and track components. This deliberate approach is conceived to achieve innovations in both vehicles and rail infrastructures. New design models and novel lightweight materials with an optimal balance in speed and axle-load, namely 25T (at 120km/h) and 17T (at 140km/h) will be implemented for freight vehicles, as well as optimized geometry, ground stabilization and novel monitoring techniques will be adopted for higher reliability and reduced maintenance of the track components.

PROJECT STRUCTURE

<p>WP1: Benchmarking Objective: To determine the 'best' state, i.e. performance of the existing freight vehicles and tracks. - Data on existing freight vehicles and tracks.</p> <p>WP2: Duty Requirements Objective: To determine the current and future requirements of the rail freight system. - Track design and vehicle performance requirements.</p> <p>WP3: The Freight Train of the Future Objective: To study freight vehicle components that identify the cost contributions to enable higher vehicle and track component design to reduce their impact on freight train monitoring and operation.</p> <p>WP4: Sustainable Track Objective: To identify track design parameters that can contribute to reduce impact of freight trains. - Performance based design criteria for freight trains. - Multi-path monitoring systems to reduce maintenance.</p>	<p>WP5: Business Case Objective: Cost benefit analysis of proposed vehicle and track modifications including: - RMTS and LCC analysis and benefit models. - Annual operating and financial expenditure and energy demand.</p> <p>WP6: Technology Demonstration Objective: Demonstration of new and novel upgrades on test and track trials at NRES test track. - Safety of approach track and vehicle, axload, performance etc.</p> <p>WP7: Demonstration and Exploitation Objective: Field demonstration and validation using freight trains under various conditions, including: - Safety, ground, operation and performance. - Operation and maintenance.</p> <p>WP8: Project Coordination Objective: Administration, legal and financial issues. - Bringing user perspective and communication. - Administration and technical coordination.</p>
---	---

KEY INNOVATIONS

VEHICLE INNOVATIONS
 The design of a novel height bogie capable of running at up to 140km/h with reduced track forces compared with conventional height bogies. The design of the Sustrail height bogie has been patented and a prototype is being manufactured.
 The Sustrail freight vehicle includes:
 - Novel spring gear using components based on the widely used V25 suspension which means that it can be maintained using established techniques, equipment and staff.
 - One axle and an electronic braking system to ensure safe operation at the higher operating speeds.
 - Wheel sets with high tech coatings which will reduce inspection costs.
 - On-board condition monitoring to allow longer maintenance intervals.
 - Noise reduction elements to meet anticipated legislation.
 - Modern lightweight structural design.

TRACK INNOVATIONS
 - Advanced condition based predictive maintenance tools for critical components of both railway vehicles and the track.
 - Identification of performance based design principles to move towards the zero maintenance ideal for the rail freight system.
 - Construction of the ballast system and novel ground stabilisation and monitoring techniques to reduce track geometry degradation.
 - Construction of the track system and geometry, including switches and crossing.

BUSINESS CASE BENEFITS
 The Sustrail approach, based on innovations in both rolling stock and track structures, has impact on both infrastructure and vehicles and so the economic benefits are to be found on both sides of the wheel-rail interface:
 - A strong impact on system reliability is achieved through the definition of performance based design principles for resilient tracks with higher reliability and targeted safety levels.
 - Significant economic savings are obtained by extending the life, durability, safety and reliability of railway infrastructures which, indirectly, will stimulate economic growth.
 - A reduction in vehicle life costs of the wagon by 6%, through reduced maintenance requirements, with additional benefits of increased wagon availability.
 - Contribution to the European Commission's goal of moving freight from the roads onto rails, which is an important step in developing a more sustainable transportation system, due to: while system cost savings which allow freight operators to increase capacity and to increase safety.
 - A significant impact on the reduction of energy use is expected, resulting in a reduction of greenhouse gas emissions.

All further information and deliverables are available online at www.sustrail.eu

Figure 15 The updated Sustrail flyer as distributed at the Final Conference on 21 May 2015

1.4.2.5 Newsletters, press release

The Sustrail Newsletter was published on an annual basis in 2011, 2012, 2013, and 2015. Newsletters have been sent to all project members and made available online on the Sustrail Public website. News on the project were also fed into the electronic newsletters of UIC and UNIFE.

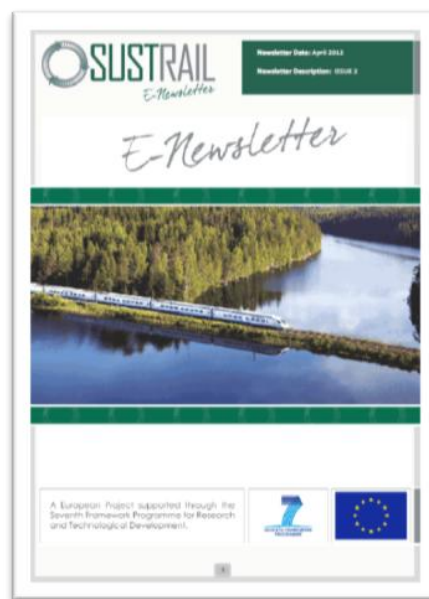

Figure 16 : Sustrail E-Newsletter

1.4.3 Publications

Scientific and academic publications and communications generally come under each WP or task leader. To ensure follow-up and facilitate the notice to the European Commission, publications have been recorded through the dissemination activity report. A list of publications and dissemination events has been directly uploaded within SESAM.

1.4.4 Exploitation

The main project innovations and their path to technical implementation have been extensively investigated. The results are provided in D5.4 “Technical implementation and phasing issues”. For innovation the following criteria have been analysed:

- Innovation type
- Innovation owner
- Innovation beneficiary
- Implementation timing
- Dependencies

An extract of the main outcomes of D5.4 is reported below for both vehicles and infrastructures innovations.

Innovation	Owner	Beneficiary	Implementation Timing	Dependencies
Novel running gear	Huddersfield	Vehicle Operator	Predicted 2017	New bogie required to accommodate the novel suspension. Prototype testing to be concluded with development to final product.
Axle mounted disc brakes	KES	Vehicle Operator & Infrastructure Manager	Available 2015	New bogie required to accommodate the revised braking system. Training for maintenance techniques and local certification if required. This may be restricted for use only for wholly disc brake equipped trains.
On-board axle box temperature monitoring	MERMEC	Vehicle Operator	Predicted 2017	Power supply and communication to be included in future development. Prototype testing to be concluded with development to final product.
Spring inserts for reduction of structure-borne noise emissions	TUB	Vehicle Operator & Infrastructure Manager	Predicted 2016	Known technology for passenger train application. Prototype testing to be concluded with development to final product.
Vehicle: Axle Coating	LUCCHINI	Vehicle Operator & Owner	Predicted 2016	Development of non-destructive testing process required with associated training and local certification if required.
Wagon wheel set	GTU	Vehicle Operator	Predicted 2018	Prototype testing to be concluded with development to final product.
Friction modifiers	GTU	Vehicle Operator & Owner	Predicted 2017	Friction modifier testing to be concluded with development of dispensing system.

Innovation	Owner	Beneficiary	Implementation Timing	Dependencies
Aerodynamic fairings	USFD	Vehicle Operator	Predicted 2016	Prototype testing to be concluded with development to final product.
Premium rail steel (plain line)	Tata Steel	Infrastructure Manager	Available 2015	Training for welding techniques and local certification if required.
Premium rail steel (S&C)	Tata Steel	Infrastructure Manager	Available late-2015	Development of welding repair techniques and local certification if required.
Fatigue life prediction	USFD	Infrastructure Manager	Predicted for 2018	Further development of model and verification required.
Effect on track forces by changing rail profile	LTU	Infrastructure Manager	Predicted for 2016	Training for welding techniques and local certification if required.
Sensors in geo-textiles	TRAIN	Infrastructure Manager	Available late-2015	Installation of the sensor-embedded geo-grids requires extra care compared to normal geo-grids in order to prevent failure of the optical fibre
Impact of inspection and monitoring technologies	DAMILL	Infrastructure Manager & Train Operator	Available 2015	Development of alarm settings for specific vehicles and routes.
Switch lubrication testing	USFD	Infrastructure Manager	Available 2016	Environment testing facility to be procured to extend testing temperature range (2016 on)
Smart Washer	Huddersfield	Infrastructure Manager	Predicted 2018	Prototype testing to be concluded with development to final product.
Rail Fastening Device	GTU	Infrastructure Manager	Predicted 2017	Prototype testing to be concluded with development to final product.

1.5 Project Public Website

1.5.1 Project website

The project website, of which a complete description can be found in deliverable D7.1 “Kickoff Material: Webpage, Brochure, Press Release” is divided into a public webpage and a private platform. The public area is the tool of choice for hosting communication materials and disseminating project activities to a vast audience. It provides information on project’s objectives and duration, EU funding, participants list, etc.

The project website is available at: <http://www.sustrail.eu>



The screenshot shows the homepage of the Sustrail website. At the top left is the Sustrail logo, which consists of a circular graphic with arrows and the word 'SUSTRAIL' in green. To the right of the logo are the logos for the 'SEVENTH FRAMEWORK PROGRAMME' and the 'European Commission', with the text 'Project co-funded by the European Commission' below them. A search bar is located in the top right corner. Below the logo is a breadcrumb trail: 'Home page / Edito / About SUSTRAIL'. The main heading is 'About SUSTRAIL' in green, with social media icons for Facebook and RSS to its right. The main content area starts with the text: 'The sustainable freight railway: Designing the freight vehicle – track system for higher delivered tonnage with improved availability at reduced cost'. This is followed by a section titled 'Objectives' with the text: 'The Sustrail objective is to contribute to the rail freight system to allow it to regain position and market, accounting for:'. A bulleted list follows: '- The increase of the demand of the total freight transport volumes: 40% (in tonne-kilometres) by 2030 and 80% by 2050;', '- The shift of 30% of road freight over 300km to other modes such as rail or waterborne transport by 2030 (50% by 2050) as targeted by the European Commission.'. Below this is a paragraph: 'Within this framework and motivated by the necessity and opportunity for change in rail transport, Sustrail provides the approach, structure, and technical content to improve the Sustainability, Competitiveness, and Availability of European railway networks thanks to an integrated approach.'. Another paragraph follows: 'Innovations in rolling stock and freight vehicles combined with innovations in the track components will be pursued by:'. A final bulleted list: '- adopting a holistic approach;', '- implementing a clear methodology and viable procedures', '- setting up appropriate business cases'. On the right side, there is a vertical navigation menu with green buttons for: 'About SUSTRAIL', 'Participants', 'Virtual demonstration', 'Publications', 'Deliverables', 'News', 'Events', 'Contact', and 'Members area'. At the bottom right, there is a large, stylized circular graphic with arrows, similar to the Sustrail logo.

Figure 17: Screenshot of the public website homepage.

In the end, the public website now contains 9 public pages:

- About SUSTRAIL
- Participants
- Virtual demonstration
- Publications
- Deliverables
- News
- Events
- Contact
- Members area

The sections Virtual demonstration, Publications, Deliverables, News, Events have been added to host and facilitate public access to dissemination and information documents. The private area is accessible from the public webpage by clicking the link “Members Area” on the page menu or at (<http://ovidientia.uic.org>).

This tool is the platform where documents and information of any type can be uploaded and made available by and for the project partners.

Access to the Members Area is restricted to the Consortium members only, with access rights depending on their role and implication level. After 48 of activity, 103 persons have received various access rights to the SUSTRAIL private area.

2 Use and dissemination of foreground

Additional Scientific Publication not inserted on SESAM (D.O.I. not recognized by the D.O.I. database) are provided in the table below

Section A (public)

TEMPLATE A1: LIST OF SCIENTIFIC (PEER REVIEWED) PUBLICATIONS, STARTING WITH THE MOST IMPORTANT ONES										
NO.	Title	Main author	Title of the periodical or the series	Number, date or frequency	Publisher	Place of publication	Year of publication	Relevant pages	Permanent identifiers ¹ (if available)	Is/Will open access ² provided to this publication?
1	Experimental research into friction modifiers for the tread, flange and gauge surfaces of wheels and rails	G.I. Tumanishvili, M. Tedoshvili, V. Zviadauri, G.G. Tumanishvili	Transportation №1(7), 2014	01/07/2014	EnergyOnline	Tbilisi	2014	1-5	http://www.energyonline.ge/energyonline/index.php?option=com_content&view=article&id=203&Itemid=185&lang=en	Yes
2	Improving of operating ability of wheels and rail tracks	George Tumanishvili, Tengiz Nadiradze, Ioseb Tumanishvili	Transport Problems,	Volume 9, Issue 3, 18/08/2014		Katowice,	2014	99-105	http://transportproblems.polsl.pl/pl/Archiwum/2014/zeszyt3/2014t9z3_11.pdf	yes

¹ A permanent identifier should be a persistent link to the published version full text if open access or abstract if article is pay per view) or to the final manuscript accepted for publication (link to article in repository).

² Open Access is defined as free of charge access for anyone via Internet. Please answer "yes" if the open access to the publication is already established and also if the embargo period for open access is not yet over but you intend to establish open access afterwards.