

PROJECT FINAL REPORT

Grant Agreement number: ACP8-GA-2009-233926

Project acronym: INFUCOMP

**Project title: SIMULATION BASED SOLUTIONS FOR INDUSTRIAL MANUFACTURE OF
LARGE INFUSION COMPOSITE PARTS**

Funding Scheme: SMALL OR MEDIUM-SCALE FOCUSED RESEARCH PROJECT

Period covered: from 1st October 2009 to 31st September 2013

Project co-ordinator name, title and organisation: Anthony Pickett, Dr, ESI GmbH

Tel: +49-6196-95830

Fax: +49-6196-9583 111

E-mail: akp@esigmbh.de

Project website address:

<http://www.esi-group.com/corporate/alliances/projects/INFUCOMP/INFUCOMP>

1. Final publishable summary report

1.1 Executive summary

Today, advanced composites use either layers of plies impregnated with resin (pre-pregs) to form a laminate, or Liquid Composites Moulding (e.g. RTM) of dry textiles. Prepreg composites give superior mechanical properties due to toughened resins and high fibre content, but suffer from high material costs, limited drapeability, complex, expensive and time consuming manufacturing, and limited materials shelf life. Infusion technologies can overcome these limitations, but are not fully industrialised and rely on costly prototype testing due to the lack of simulation tools. Current infusion simulation technologies are approximate and really only suited to small scale components based on adaptations of Resin Transfer Moulding simulation; they are not accurate for large, thick and complex aerospace composites, where one sided tooling and vacuum membranes cause complex 3D heat/flow processes.

The INFUCOMP project will develop the full simulation chain from preform design to manufacture (infusion), process/part optimisation and final part defects/mechanical performance prediction with a focus on the infusion step. The project covers all popular Liquid Resin Infusion (LRI) methods currently used in the Aerospace industry. Although focus is on aerospace applications, the work will be very relevant to other industries. The proposed technologies will allow economical manufacture of high performance, integrated, large scale composite structures; thus, positively contributing to their increased use. Benefits include lower cost, improved performance, greater payloads and fuel/emissions reductions.

A team of four aircraft manufacturers, a materials manufacturer, university and industry researchers, and a commercial software specialists; all with a recognised track record in this field; one partner is an SME.

1.2 Summary description of project and objectives

To date, manufacture of advanced composites in the Aerospace industry mostly uses pre-impregnated composite materials, tape laying technologies and autoclave curing for the production of large, high performance structures and components. These combined technologies allow toughened resins to be uniformly dispersed in a well-controlled fibre system with a high fiber content, producing excellent mechanical stiffness, strength and fatigue resistance properties. However, there are drawbacks, including high material costs, limited shapeability, complex, expensive and time-consuming manufacturing, and short materials shelf life. As a consequence alternative manufacturing methods are being sought based on Liquid Resin Infusion (LRI) technologies in which the resin is infused only after all dry textiles are assembled to form the final composite component configuration. This assembly, prior to infusion, is called a preform. The advantages are lower material and material storage costs, indefinite shelf life (for the textiles) and the ability to manufacture integrated structures having complex geometries only limited by shapeability of the dry preforms.

Currently, LRI of large composite structures require 'trial and error' testing and considerable experience on the part of designers and manufacturers to get the correct set-up. The high cost and risks involved will often lead to overly conservative infusion designs with associated cost and performance penalties; or may lead to alternative, less competitive, manufacturing technologies and materials being adopted.

Infusion of dry fabrics may be undertaken using a variety of processes. The first popular method is Resin Transfer Moulding (RTM) which is widely used for the manufacture of small to medium sized components and is especially suited to automation and the manufacture of relatively high production volumes. High injection pressures can be used to reduce infusion time, but is in practice limited by stability of the tooling and effects such as porosity and fibre distortion which may occur especially in the vicinity of the injection ports. The main limitations are high cost and size (weight) of the two part tooling, and relatively long cycle times needed to cure the resin before the part is sufficiently stable to be extracted from the mould. The key steps in RTM are shown in Figure 1 below and involve shaping the preform, extraction and trimming of the preform, and resin infusion in sealed matched (usually metal) tooling.

As mentioned some limitations of RTM are high cost, weight and complexity of tooling. Liquid Resin Infusion can overcome these problems and requires only one sided tooling, which may be significantly lighter and therefore cheaper. Figure 1 below shows the essential features of LRI. A dry fabric is laid up in the tooling, usually with a low permeability flow medium to aid infusion, and a peel ply and/or release ply to help separation of the final composite and flow medium after curing of the final part. The complete setup is sealed in a vacuum bag that prevents air entering the system; vacuum is applied at one location (outlet port) and draws resin from an inlet port through the dry fabric. Large complex parts invariably need a system of inlet and outlet ports which may use synchronised opening and closing to enable complete infusion of the large volume. Also shown in Figure 2 is an intermediate stage of the infusion of an aircraft composite fairing.

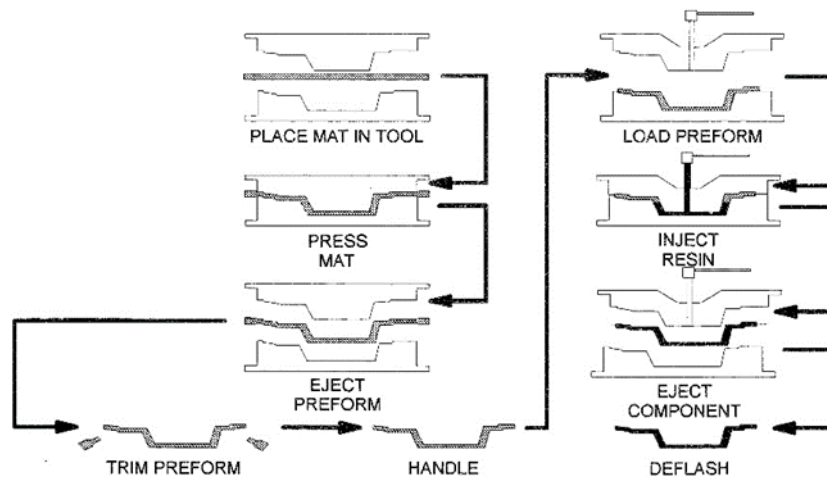

Figure 1:

pre-forming and RTM infusion (Rudd, et al. 1997).

Steps in

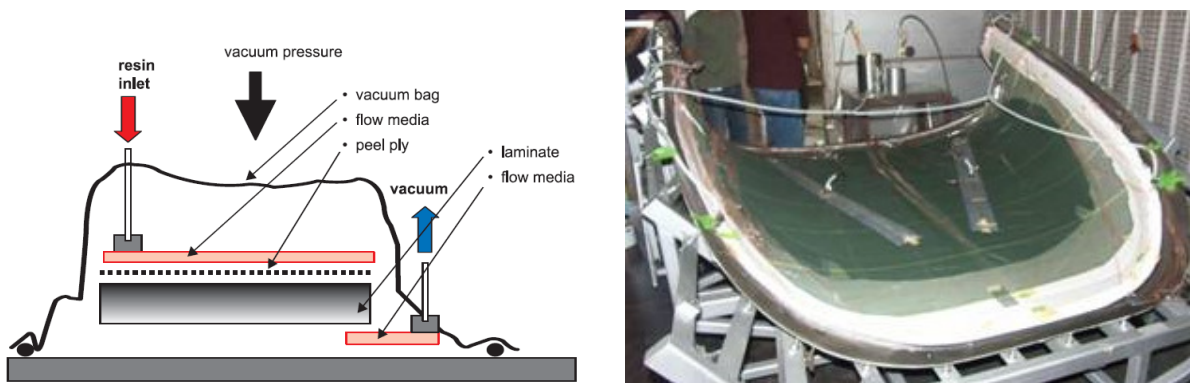

Figure 2: The LRI infusion set-up and an industrial example (Courtesy IAI)

The scientific aim of the CEC INFUCOMP project was to provide a full simulation chain for LRI manufacture of large aerospace composite structures dedicated to solutions required by the European Aircraft industry. Extensive materials testing for a range of dry fabrics and permeability characterisation was conducted from which new constitutive laws were developed. Software developments were implemented into an existing infusion code PAM-RTM™ which has essentially been developed for Resin Transfer Moulding (RTM) processes. Some other specific developments included process optimisation, cost analysis and predictive tools to characterise imperfections such as porosity and residual stresses. One major software development was extension of current scalar computing capabilities so that advantage may be taken of State-of-the-Art massive parallel computers; this has allowed a step change to full 3D infusion modelling involving tens of millions of elements. The new capabilities were validated on a series of demonstration studies of representative parts using the different infusion technologies actively used at the four industrial partners sites.

The consortium was led by a software company (ESI) who have developed further the existing PAM-RTM software code, based on scientific contributions from university, materials and research partners. An important aspect of the project was development of a series of demonstrator parts undertaken by the industrial partners; this has helped validate and industrialise the new software developments.

In detail the consortium included:

- Four aircraft manufacturers: Bombardier Aerospace, Belfast (UK), Piaggio Aero Industries S.p.A (Italy), Daher Aerospace (France) and Israel Aerospace Industries (Israel).
- One material manufacturer: Hexcel (France).
- One simulation software supplier: ESI Group (France) and ESI GmbH (Germany).
- An infusion sensor specialist INASCO (Greece).
- Four academic partners: Cranfield University (UK), University of Patras (Greece), Ecole des Mines de Douai and Saint-Etienne (France), and Katholieke Universiteit Leuven (Belgium).
- Two institutes: The Institute for Aircraft Design, IFB (Germany) and SWEREA SICOMP (Sweden).

The overall project objectives included:

- A validated series of industrial studies on various Liquid Resin Infusion (LRI) processes.
- Successful application of the new software to show it may be efficiently and reliably used to model LRI processes.
- A new LRI software adapted to DMP computer architecture, so that 3D models having tens of millions of finite elements may be performed and results efficiently post-processed.
- New test methods and data to characterise draping and compaction of fabrics.
- New material models to predict fabric draping and compaction.
- New test data and constitutive laws to characterise resin viscosity specifically suited to infusion processes.
- Solutions to resolve known computational stability problems at the flow media-to-fabric interfaces.
- New work and progress in modelling manufacturing defects of LRI composites, including residual stresses, porosity and surface finish.
- Validated methodologies for costs modelling and optimisation of LRI processes.

1.3 Description of the main S&T results/foregrounds

A brief description of the project structure is first given with details of the work undertaken for each work package. This is then followed by further details for each work package.

The structure of the project and the main work packages are presented below and in Figure 3.

Work package interaction(s):

1. Briefly, WP's 2 and 3 perform fabric deformation and resin viscosity/permeability measurements respectively.
2. The mechanical data obtained from WP2 and WP3 was directly used to develop new fabric deformation models at the macro- and meso- scales (WP2) and for new permeability data for deformed fabrics (WP3); both of which were implemented into the new software (WP5).
3. WP4, WP6, WP7 and WP8 all developed necessary associated simulation technologies. In each case the developments were undertaken and then used for collaborative and validation studies with end-users.
4. Final validation of the CAE tools and procedures was undertaken in WP9.

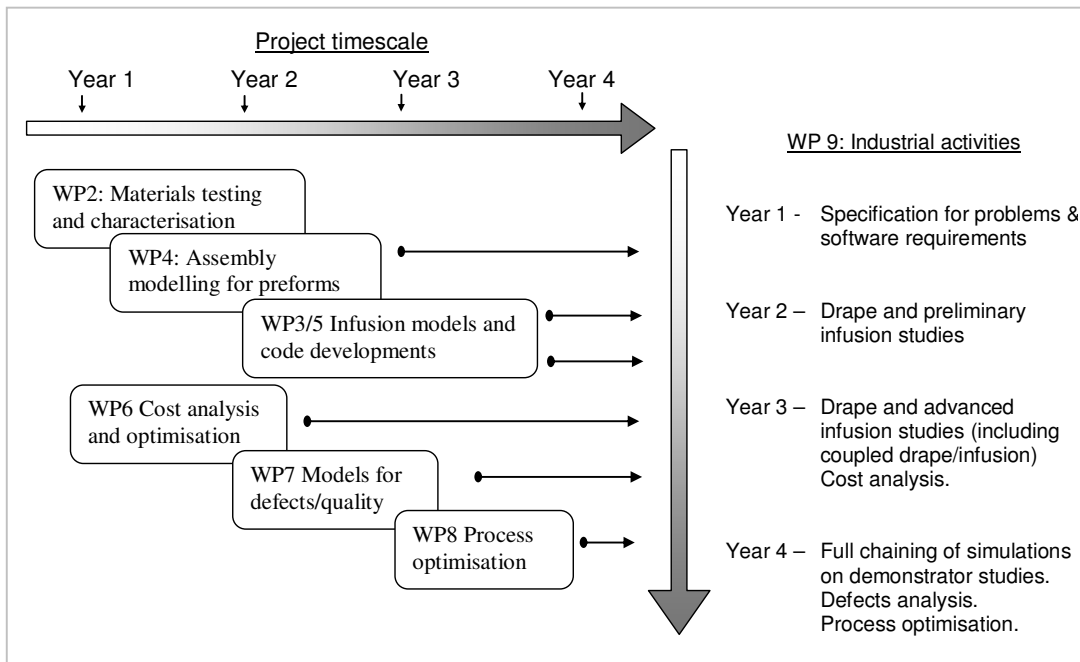

Figure 3: Interaction of the project work packages

The following sections briefly present each work package including objectives, some work and the main results achieved.

Work package 1: Management

This task concerned management and financial control aspects of the project.

Work package 2: Fabrics characterisation

Objectives of the work package

1. New tests on the selected project fabrics were performed to gather essential data on deformation, shear and through-thickness compression behaviour for modelling investigations.
2. The modelling work followed two parallel (but interrelated) routes;
 - a. Macro-models developments for new models to be implemented in the draping software PAM-FORM,
 - b. Meso-modelling to extend the WiseTex software and develop new modelling strategies.

Brief description of the work package

Table 1: Summarises the activities of partners in WP2 and the main deliverables achieved.

| Task | Partner(s) | Achievement |
|-------------------------------------|---------------------------|--|
| Test program for fabrics | KU Leuven, Hexcel, SICOMP | Deformation resistance and change of thickness during forming fully characterised for a set of typical carbon fabrics |
| New tests for fabrics | KU Leuven Hexcel, SICOMP | New test rigs and methodologies |
| MACRO constitutive models (draping) | ESI GmbH | New features implemented in PAM-FORM: Non-symmetric shear, bending |
| MESO constitutive models (forming) | KU Leuven | New numerical tools for transformation of WiseTex models into Abaqus. New open data exchange and scripting in WiseTex. |
| | SICOMP | Hyperelasto and hypoplasticity model of a transversely isotropic fibre bed (implemented in Abaqus) |
| | ESI GmbH/IFB | Large scale meso- scale models of NCF |

Table 1: Summary of WP2 involvement and activities in INFUCOMP

The reinforcements shown in Figure 4 were identified as the project fabrics and tested for formability using the following test procedures:

- PF with thickness (KUL)
- Bias with thickness (KUL)
- Compression sheared (KUL)
- Biaxial tension (KUL)
- Yarn compression (KUL)
- Out-of-plane shear (SIC)
- No-homogenous stress-strain state (SIC)
- Compression sheared (HEX)

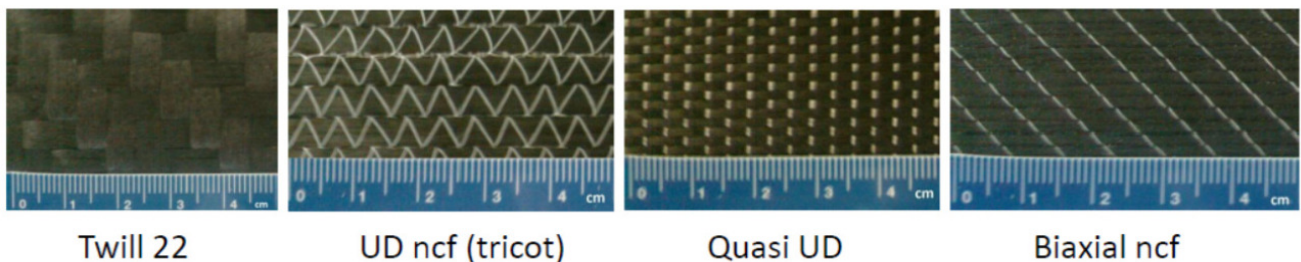

Figure 4: Carbon fibre reinforcements

As part of realisation of the test program, new test methods and test rigs were developed and implemented in laboratories of the partners. These included:

- In-situ thickness laser measurements on picture frame (KU Leuven)
- Yarn compressibility tester (KU Leuven)
- Picture frame test in thermal camera (KU Leuven)
- Micro-scale forming (KU Leuven)
- Three-axial rheometer (Swerea SICOMP)
- Compression & shear measurement (Hexcel)
- Non-homogeneous stress-strain state (Swerea SICOMP).

Meso-modelling KU Leuven

The following components of meso-level models were developed in KU Leuven (Figure 5):

- Transformation of the WiseTex geometrical models into FEA software (Abaqus).
- New version of WiseTex software, which allows integration with custom software via XML data transfer and command line scripting.

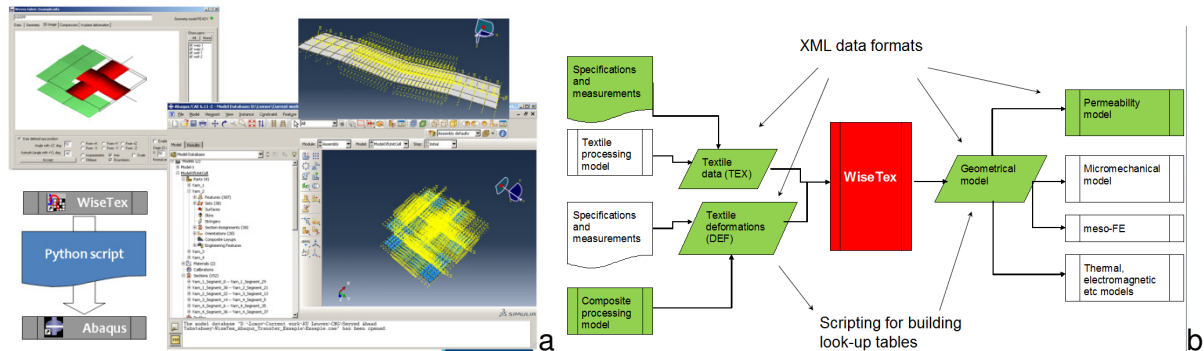

Figure 5: New meso-scope models developed in KU Leuven; (a) transformation of geometric WiseTex model in Abaqus; (b) data flow in the new version of WiseTex software

Macro-modelling ESI GmbH

ESI GmbH had responsibility to develop new macro-models for fabric draping simulation (Macro-modelling of deformability of reinforcements). Furthermore, with IFB Stuttgart new work was also undertaken on meso-scale modelling of drape and coupling to infusion. For the macro-developments the new software capabilities were implemented in PAM-FORM for non-symmetric shear behaviour, fabric bending behaviour and shear-thickness coupling. The work was primarily validated against test samples.

Meso-modelling of fabric deformation ESI GmbH and IFB

A methodology was developed for the meso-mechanical simulation of fabrics; for this work effort focused on the binded Carbon Biaxial $\pm 45^\circ$ NCF. Briefly this work included:

1. Development of a CPU efficient unit cell representation of the fabric.
2. Testing and modelling of tow axial, bending and transverse deformation behaviour.
3. Testing and modelling for inter-tow stitching.

4. Inter-tow and tow to metal (tooling) friction.
5. Testing and modelling for fabric shear behaviour.
6. Final validation using a hemisphere demonstrator.

This research led to one peer reviewed publication¹ where further details may be found.

Meso-modelling SICOMP

SICOMPs developed a constitutive model for assemblies of parallel fibres as used in composite preforms. These were expected to be strongly anisotropic and display a complex variety of responses in different directions, ranging from simple elasticity to granular flow depending on the orientation and mode of deformation. In consequence, to describe this behaviour we combined a hyper-elastic non-slip response based on a strain energy potential, for the volumetric mode and extension in the fibre direction, with plastic frictional slip modes based on a stress energy potential, for the transverse and longitudinal shear modes. To allow for this, we divided the Cauchy stress σ into two parts: a conservative, hyper-elastic, stress σ_o and a non-conservative stress σ^* . The conservative stress is due to transverse compression and longitudinal extension of the fibre bed, and is therefore linked directly to the volume fraction ϕ and fibre extension λ . The non-conservative stress was assumed due to frictional shear forces and described in the spirit of granular solids (cf. Kolymbas 2000), by the means of a differential evolution law.

Main results of the work package

Experimental:

- A database of experimental data on deformation behaviour of typical carbon fibre textile reinforcements was created for use for Liquid Resin Infusion (LRI) design and for validation of numerical methods.
- Experimental procedures, methodology and new test rigs was developed for characterisation of deformation behaviour of textile reinforcements for LRI.

Simulations and Meso-modelling:

- Meso-level deformability models of textile reinforcements were advanced toward large scale multi-unit cell models and coupling between models of deformation and infusion.
- Improved models for fabric deformation were developed for application at the macro- scale.
- New versions of software packages PAM-FORM and WiseTex were released.
- The potential to model fabrics at the meso- scale and couple this to a permeability infusion simulation was demonstrated (IFB).
- A hyperelastic/hypoplastic fully tensorial constitutive model of textile reinforcement was developed and implemented into both Matlab and Abaqus.

¹ Sirtautas J, Pickett AK and Lépicier P, „A mesoscopic model for coupled drape-infusion simulation of biaxial Non-Crimp Fabric,“ Composites: Part B, Nr. 47, pp. 48-57, 2013.

Work package 3: Resin and permeability characterisation

Objectives of the work package

1. Experimental testing of selected project resin systems was undertaken to supplement published and manufacturer's data.
2. Hydraulic (wet) and air (dry) permeability testing on undeformed and deformed fabrics was performed to develop new permeability models.
3. Constitutive permeability modelling followed two routes:
 - a. Macro-models were developed and implemented in the infusion software.
 - b. In parallel the FlowTex software was extended to include meso-mechanical models for computer based prediction of dry and wet fabric permeability.

Brief description of the work package

Resin viscosity

A new framework for viscosity modelling of thermosetting systems was developed and applied to two aerospace grade resin systems under infusion conditions. Viscosity is represented as a function of two state variables, temperature and a reference viscosity. The reference viscosity follows its own kinetics described as follows,

$$\frac{d \ln \eta_o}{dt} = A e^{-E/RT} \left(\ln \frac{\eta_o}{\gamma} \right)^m$$

which includes a rate constant with an Arrhenius dependence on temperature (T). A and E are the pre-exponential factor and the activation energy of the Arrhenius function respectively. The rate of change has an autocatalytic dependence on the logarithm of reference viscosity, with m being the order of this dependence and γ a coefficient. The viscosity was calculated using the value of reference viscosity resulting from integration of the above equation to give,

$$\eta = \eta_o e^{D \left(\frac{1}{T} - \frac{1}{T_o} \right)}$$

where T_o denotes reference temperature and D is a temperature depend coefficient. Figure 6 gives equivalent analytical expressions for viscosity (μ) and shows a comparison of test and analysis.

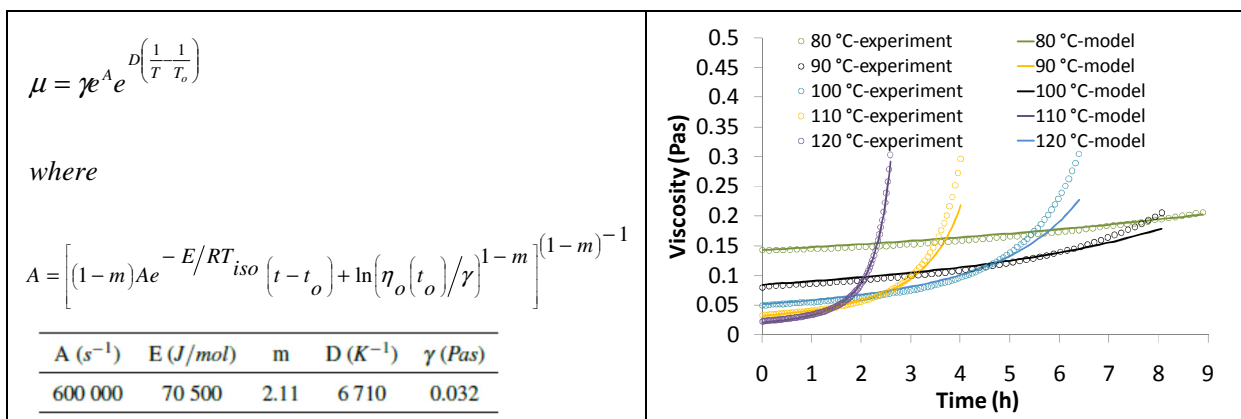

Figure 6: The analytical model for resin viscosity and example test versus analytical results

This model allows substitution of degree of cure, which is traditionally used as the underlying variable in viscosity models, with a reference viscosity which results in a more accurate and efficient representation of viscosity development under infusion conditions. An experimental data set of viscosity development during 5 isothermal, 2 dynamic, 1 cyclic and 1 complex profile was acquired for each resin system. The new viscosity model was implemented in PAM-RTM by ESI Group and validated.

Hydraulic permeabilities of reinforcements are key parameters for infusion simulation. Due the 3D nature of the flow in LRI processes, both in-plane and through-thickness permeabilities are required, and for both permeabilities many experimental set-ups and protocols have been developed. Hydraulic permeability is known to be subjected to significant variation, depending on the fabric multi-scale architecture, consequently efforts have now to be made to standardize measurements. A mathematical modelling of hydraulic permeability, available in the literature, was implemented in the infusion software by ESIF. The objective of this task was to perform hydraulic permeability tests (in-plane and through-thickness permeability) on undeformed fabrics and use results to develop new permeability models.

The through-thickness and inplane permeability measurements were performed on fabrics having different Fibre Volume Contents (FVC). The tests were performed on five fabrics; three from Hexcel (Fabric 48302, UD Tape X0505 and G1157), and two from other manufactures (Carbon UD NCF and carbon Biaxial NCF).

Module for reinforcement permeability calculation

The aim of this work was to help designers of infusion processes by providing a module in the ESI solutions which allows calculation of the reinforcement permeability from approximate analytical expressions. In this first version of the module the permeability is assessed using analytical and semi-empirical formulae. These have been integrated into Visual-Composite Materials and use the following permeability models:

- Kozeny-Carman model (for UD's)
- Gebart model (for UD's)
- Mines de Douai semi-empirical model (for Non Crimp Fabrics NCF)

Characterisation of fabric air permeability

A new method to measure in-plane permeability of fibrous media using a transient one dimensional air flow was developed. The method, based on the measurement of gas pressure at the boundaries

throughout the transient flow, is convenient, clean and fast; it also avoids the use of a gas flow meter and offers a method to study the gas transport within fibrous media.

The gas transport through fibrous porous media is described by several models to comply with different flow regimes. The permeability, which only depends on the fibrous structure, is determined by an inverse method that fits simulation results to the experimental data obtained using rising or dropping pressure methods. The results of viscous permeability K_v of GTW and CTW fabrics (K_v ranging from 10^{-11} to 10^{-10} m²) measured using gas were found to fit well to permeability measurements from conventional liquid compression and injection techniques.

Meso-models for fabric hydraulic permeability

Based on models of internal geometry of deformed reinforcements permeability of the preform was calculated by solving the Stokes-Brinkman equations of flow of a Newtonian fluid. A fast finite difference solver on a regular grid was used. To enable coupling with macro-flow simulations (Darcy solver) and forming simulation (which involves hundreds of solutions of Stokes equation for homogenising permeability in the elements), a fast permeability tool is needed. To this end, along with the further increase of computational efficiency of Stokes solver, a fast approximate method was developed based on a network-type model. Results have been validated against test measurements and a link has been developed by ESIF to couple this to the infusion code.

Main results of the work package

- A viscosity model, based on the use of a new state variable (reference viscosity) instead of the degree of cure, was developed. This model represents the rheological behaviour of epoxies under infusion conditions using a lower number parameters than conventional models based on degree of cure. This new approach allows analytical incremental integration to be incorporated into the corresponding constitutive model.
- The evolution of the viscosity of two resin epoxy systems was simulated successfully (errors below approximately 5 %) have been demonstrated using the new model.
- The new viscosity model has been implemented in the industrial software PAM-RTM and the simulation verification runs have shown behaviour in accordance with LRI processes.
- A new air permeability test rig was developed and successfully applied to test permeability of the project carbon bi-axial fabric.
- Experimental tests have quantified capillary effects, which were found to be negligible.
- A new version of FlowTex meso-modelling permeability software was developed and successfully validated.

Work package 4: Tooling, membranes and preform assembly simulation

Objectives

Test and simulation options specific to the LRI manufacturing process were developed. In particular:

1. Test and modelling methods to represent Membranes and Caul plates.

- Techniques to model preform assembly in the tooling so that correct fabric deformations and loading are obtained.
- Identification and modelling of race tracks and piping systems.

Brief description of the work package

Test and modelling of the flexible membranes

Preforming membranes were tested (Figure 7) for stress-strain curves to be used in numerical preforming simulation. Calibration work first used solid elements and the Ogden model. However, results were not entirely satisfactory and new calibrations were performed using PAM- material model 140; which were found to give improved results. Example results are shown in

Figure 8.

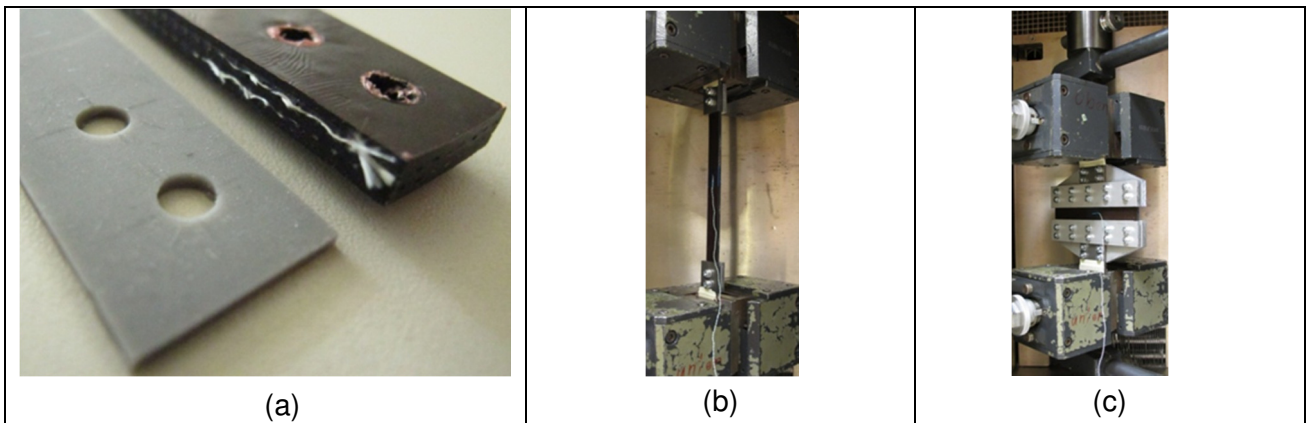

Figure 7: Thin cured elastomer and glass fibre reinforced membranes (a), uniaxial tension specimen (b) and pure shear specimen (c) in the testing machine

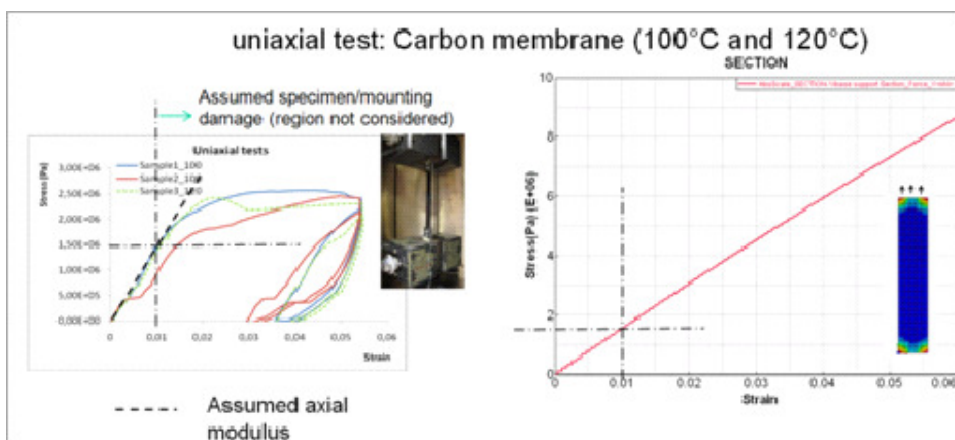

Figure 8: Membrane uniaxial tension test and simulation (orth. viscoelastic shell (Mat. model 140))

Test and modelling of Caul plates

A series of infusion trials, Figure 9a, was performed to identify an appropriate approach of testing influence of Caul plates on infusion process. The test rig was developed, Figure 9b, for testing fabrics in LRI and RTM configurations. A system of mirrors was used to monitor infusion rates and a system of springs was used to apply desired pressures up to 10 bars to the fabrics, Figure 9c.

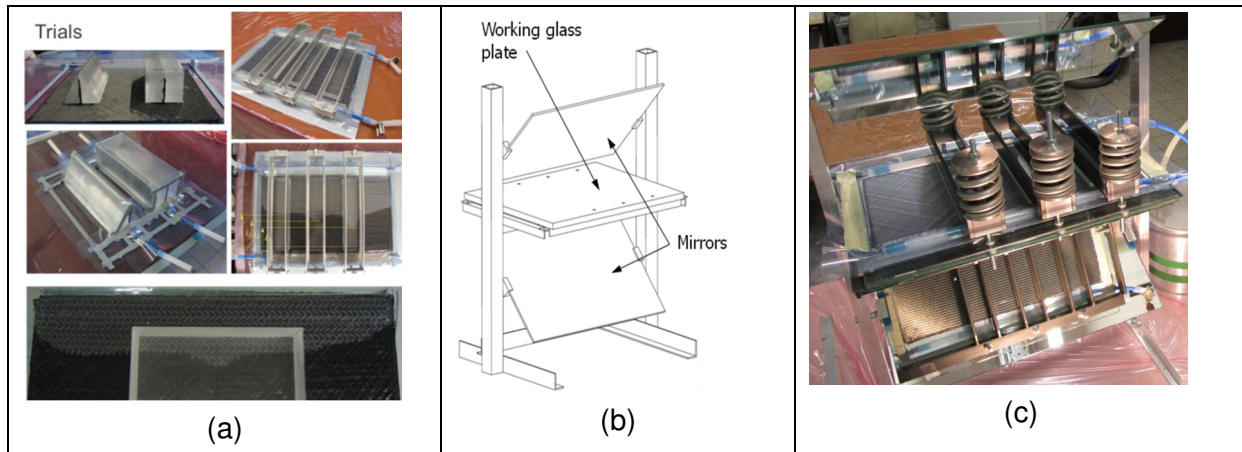

Figure 9: Infusion tests: Trials (a), schematic view of a test rig (b), test rig (c)

The following fabrics were tested under 1 and 6 bars pressure:

- Sample A Carbon UD, with binder Sample B Carbon biaxial NCF, with binder
- Hexcel G1157 D1300 (quasi UD)

A summary of estimated permeabilities obtained for the different fabrics are given in Table 2.

| Fabric | K_x, m^2 | K_y, m^2 | K_z, m^2 | $V_f, \%$ | Compaction pressure, bar | Estimated/measured by |
|----------------------------|------------------------------|------------|------------|----------------------|--------------------------|-----------------------|
| Sample A UD NCF | I – 1.0E-11 II – 2.77E-12 | 1.2E-12 | (3.0E-15) | 61.50 (DIN 29971) | 1 | IFB |
| | 1.05e-11 | | 6.38e-14 | 60 | n.a. | Hexcel |
| Sample B biaxial NCF | 1.20E-11 | 3.64E-12 | 1.90E-14 | 60.96 (DIN 29971) | 1 | IFB |
| | 3.7E-12 | 1.40E-12 | 8.0E-15 | 61.06 (DIN 29971) | 6 | IFB |
| | 1,36E-11 | | 6,41E-13 | 60 | n.a. | Hexcel |
| Hexcel G1157 | 1.5E-12 4.0E-12 | 5.0E-13 | (3.0E-15) | 69.55 (DIN 29971) | 1 | IFB |
| | 6.0E-13 | 2.5E-13 | 4.0E-15 | 66.52 (DIN 29971) | 6 | IFB |
| | 2.13E-11 | | 3.22E-13 | 60 | n.a. | Hexcel |

Table 2: Estimated fabric permeability values

Preform assembly, race tracking and validation (IFB, ESIG)

Certain LRI phenomena were investigated including racetracks, the influence of inlet pipe length and resin flow in flow media under different boundary conditions.

A series of tests were made for different shapes and sizes of race tracks. Comparisons with simulations have been made using an ‘equivalent’ permeability model and encouraging comparison to test results was obtained.

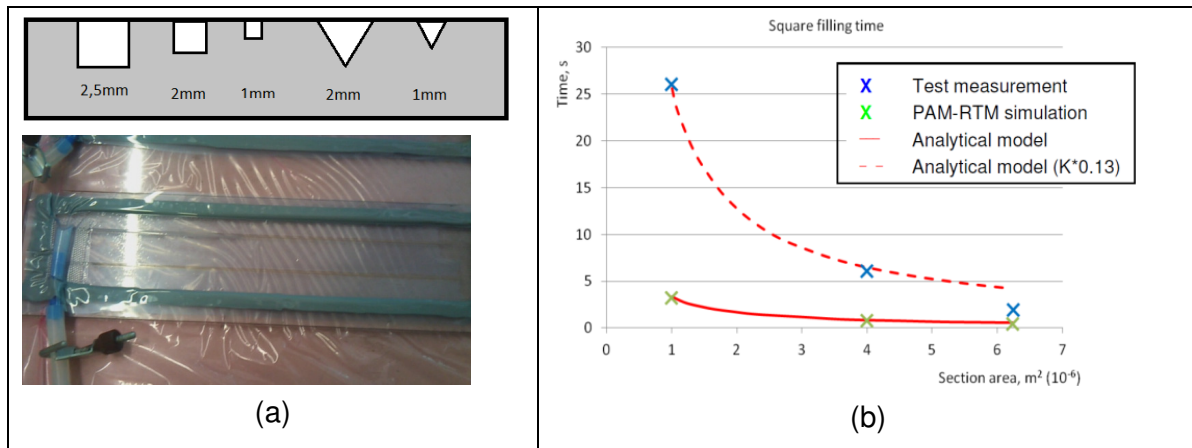

Figure 10: Tested race track geometries and view of the test (a), comparison of flow propagation from test and analytical/numerical models

Tests on two types of flow media, Figure 11, were performed under several layup configurations showing that effective permeability is strongly dependent on boundary conditions. Surrounding interfaces (e.g. flat surface of glass, deformable surface of fabric or separation foils) can considerably change the effective inplane permeability. The extent of permeability variation due to boundary conditions was also found to be dependent on the type of flow media.

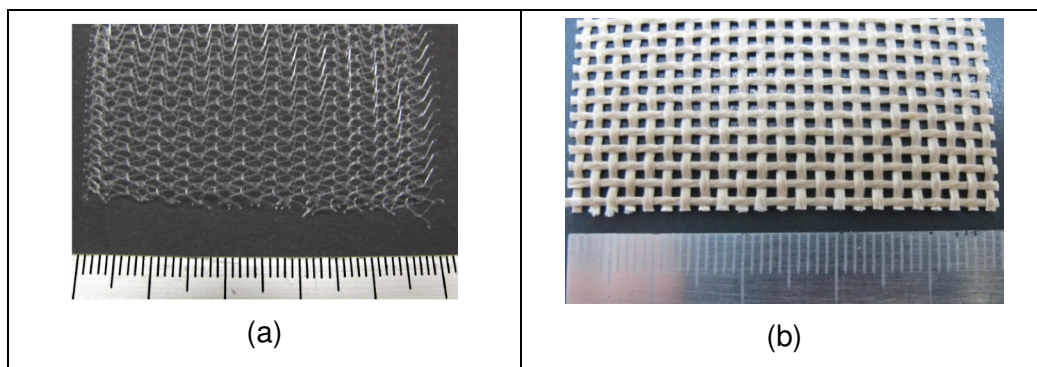

Figure 11: Two types of flow media tested: IFB (XS6262-003 „X60“X650FT) (a), Daher (Daher specification) (b)

Example results are shown in Figure 12, and Table 3, using flow media on different surfaces:

- FM on glass
- FM on fabric
- FM on perforated foil, separation foil and fabric

Due to nesting effects the inplane flow media permeability may be reduced as shown in Table 3.

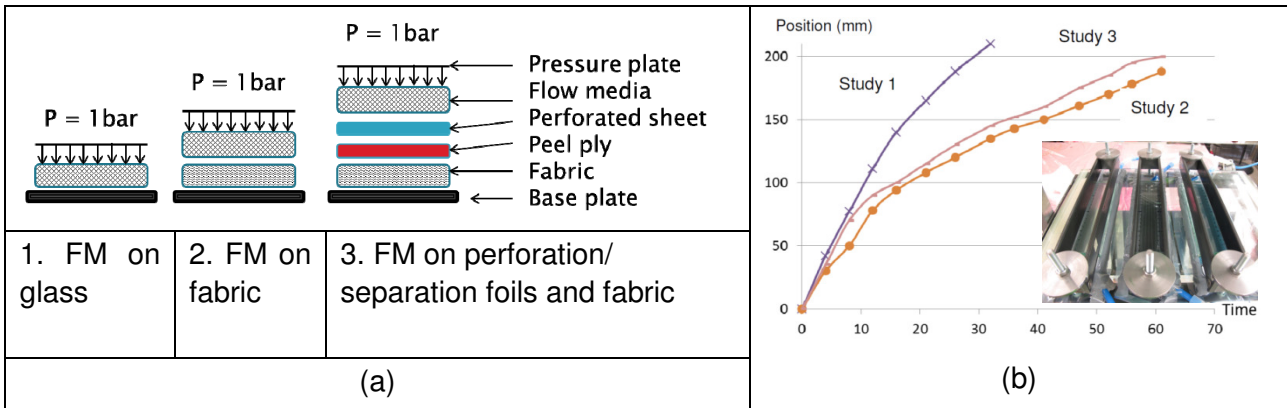

Figure 12: Flow media test configurations (a), flow fronts' propagation comparison (b)

| | FM on glass | FM on fabric | FM on perforation/separation foils and fabric |
|------------------------------|-------------|--------------|---|
| Permeability, m ² | 8.0e-10 | 3.5e-10 | <u>4.1e-10</u> |

Table 3: Flow media (IFB) permeability estimation results

Resin flow in piping system may cause substantial pressure drop due to the length of the piping systems. Experiments to investigate this effect were performed, but unfortunately, for practical reasons, only shorter length pipes (100 -1000 mm) were used and yielded no observable difference in the resin front propagation rates.

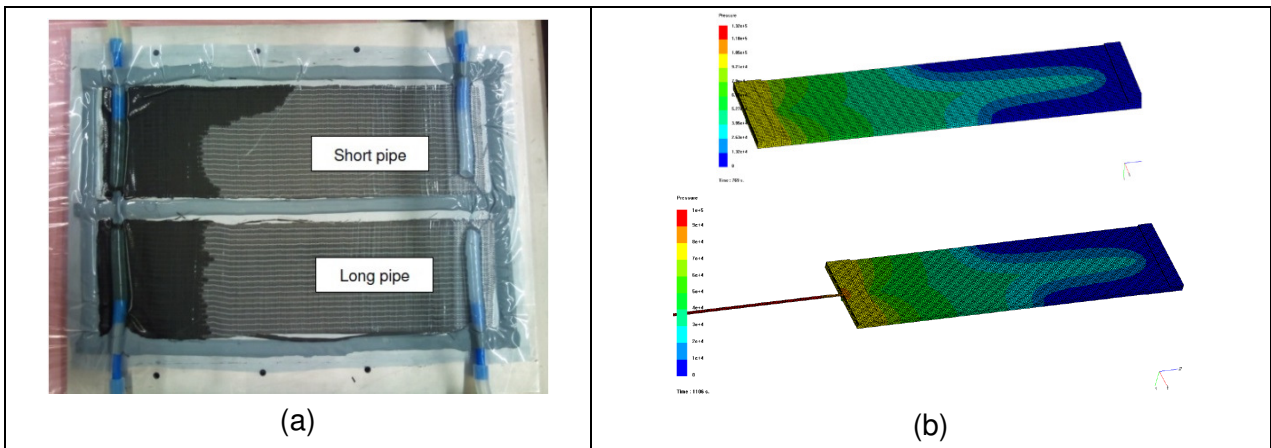

Figure 13: Flow fronts in preforms with different inlet pipes' lengths (a), pressure contour plots from the simulations without and with 1 m inlet pipe (b)

Permeability testing

Further permeability testing was conducted to support work from WP3. In particular through thickness testing using the method of Nedanov and Advani was used, with modifications to improved reliability and reduce test scatter, Figure 14.

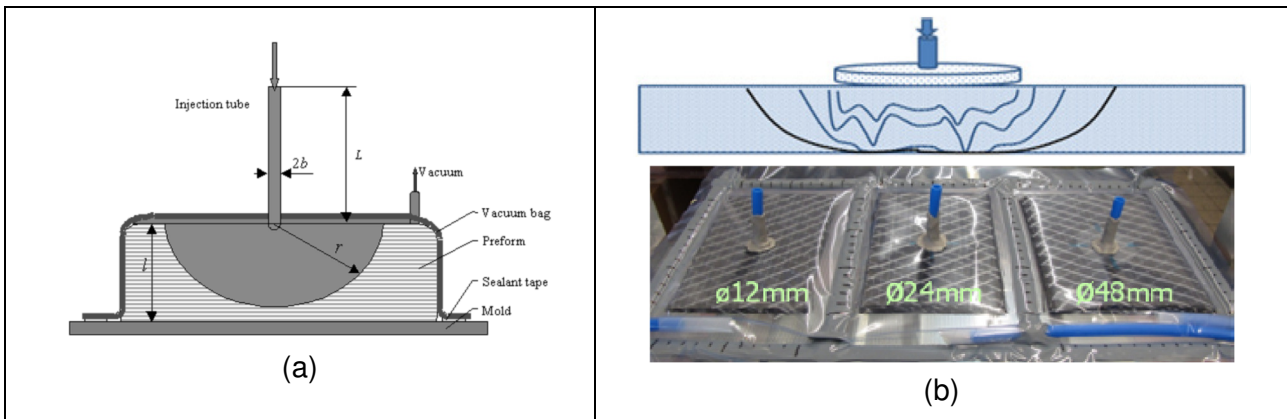

Figure 14: Point infusion test [Nedanov and Advani] (a) and a modified version of the test with distribution patch at the inlet (b)

Main results of the work package

- A rig for permeability testing of general preform assemblies was developed and commissioned; results have been obtained for the five project fabrics and used in various demonstrator studies.
- Similarly, new data for flow media and separation plies has also been measured and documented.
- Test measurements and numerical models for race-tracking have been studied and evaluated.
- Deformation measurements for shear and tension have been undertaken for the project membranes. Results have been calibrated and validated against two models in PAM-FORM.

Work package 5: Infusion simulation developments

Objectives

Necessary developments were undertaken to improve current Finite Element infusion simulation capabilities. These included both physical representation of the problem and aspects related to CPU requirements so that very large structures may be analysed. Specific work included:

1. New modelling to represent capillary effects.
2. New modelling to simulate low permeability flow media and its interaction with fabrics.
3. Parallel programming for CPU speedup and analysis of very large LRI structures.
4. Flow monitoring during infusion.

Brief description of the work package

Capillary effects

At the flow front three phases are present; namely, liquid, solid and gas (i.e. resin fiber and air). Due to surface tensions and wetting angles, capillary pressure does exist. When the flow front velocity and the local pressure gradient decrease, the capillary pressure can be of the same order as the local fluid pressure (or even predominant). Capillary-driven flows lead to poor quality composite parts. If capillary pressure becomes significant, it may be required to be represented in the simulation.

In this task, capillary pressure drop effects were investigated using experimental procedures and implement in PAM-RTM. It was found that the capillary effect, viewed at the macroscopic scale, started to become significant when both the filling time is important and the ratio between the capillary pressure and the pressure gradient is non-negligible. This can be the case in LRI processes where the capillary pressure could be significant and the time of filling may be many hours.

Modelling adjacent layers with high permeability ratio

The aim of this task was to propose a stable solution for computing Stokes-Darcy fluid flows in neighbouring regions, representing flows in draining fabric contiguous to preforms represented as porous media. The decoupled approach was implemented in ESI's software Pro-FLOT using an approach in which the flow media and fabric are treated as Stokes and Darcy flows independently, Figure 15. An iterative process ensures equilibrium between these two regions where the flows have been solved. A global convergence is sought through a residual for both flows.

Simulations were run successfully for complex 3D cases exhibiting curvatures. Figure 16, for example, shows the simulation of distribution medium filling with subsequent resin impregnation of the preform. As a conclusion, the decoupled approach can now be used to solve 2D and 3D Stokes-Darcy flows with permeability ratios down to $1e-15 \text{ m}^2$ for any interface shape and location. The source code is integrated into the PRO-FLOT software and is available for ESI.

Dedicated meshing tools for LRI simulation

ESIF has completed work to develop an LRI dedicated meshing tool. The aim was to further develop existing manual meshing methods, such as extrusion, by adding some specific cases which are not properly treated today, such as zero thickness areas. Particular attention was paid to adding an automatic material and orientation assignment within this meshing tool. Simple test parts (thickness variation, gusset fillers and stiffeners) and industrial prototypes defined in WP9 were used as target parts for validation of the new meshing tool. Figure 17 illustrates the GUI of this new development in which different laminates materials are assigned to the model (one for each colour). Ply drop-off is correctly taken into account as displayed, for example, in Figure 18.

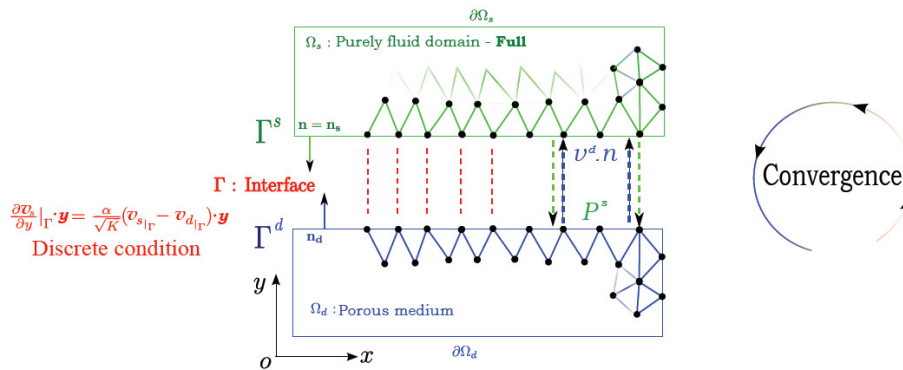

Figure 15: Decoupled approach

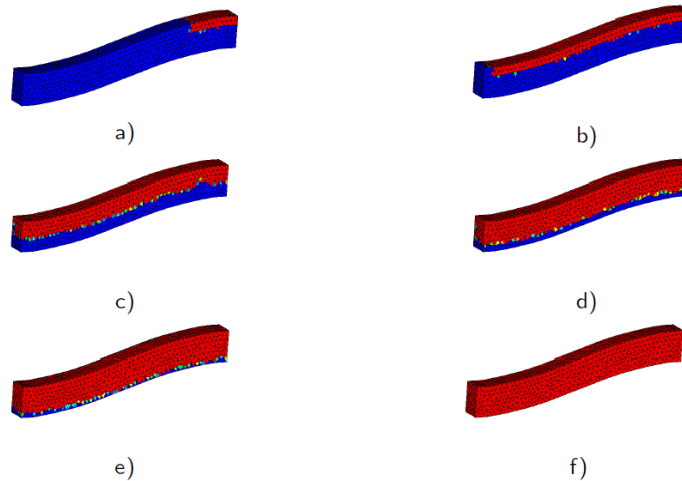

Figure 16: 3D simulation of the resin injection with draining filling, $K=1e^{-9} \text{ m}^2$

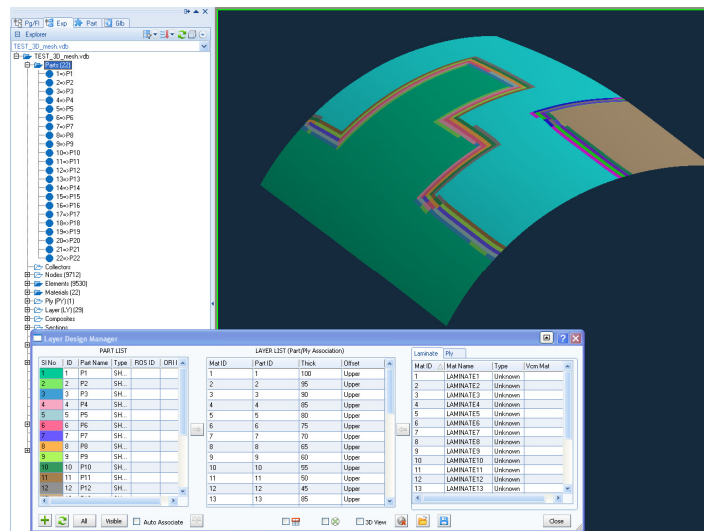

Figure 17: Laminates assignment

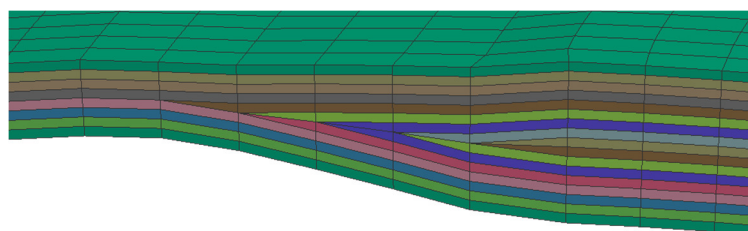

Figure 18: Thickness variation due to layer end (layers drop-off)

CPU time optimisation on parallel computers and new features

During the project several software releases were delivered to partners containing specific DMP version developments, which were used to address very large composite structure simulations.

- In 2010 the first version offering DMP solver capabilities; which was based on an entirely new source code designed for high performance and parallel execution.

- In 2011 thermal analysis capabilities were added to the DMP solver.
- In 2013 new features, such as permeability as a function of shear angle, amongst others, were added to the DMP solver capabilities.

Modelling of infusion-compression in LRI processes

In close collaboration with ARMINES an infusion simulation tool was developed for infusion-compression based on the previous work of P. Celle. The unique feature of this method is the global vision of the process. While most of the usual methods represent only the resin flowing in the rigid preforms, we are now able to treat flows in the distribution medium and in the preforms which also undergoes finite deformations. The approach is based on a decomposition of the domain into three zones, Figure 19:

- Stokes zone: Fast flow zone constituted of the distribution medium and the resin.
- Darcy zone: Incompressible flow of the resin in the preforms submitted to finite deformations.
- Dry preform zone: This comprises the non-impregnated preforms submitted to finite strains.

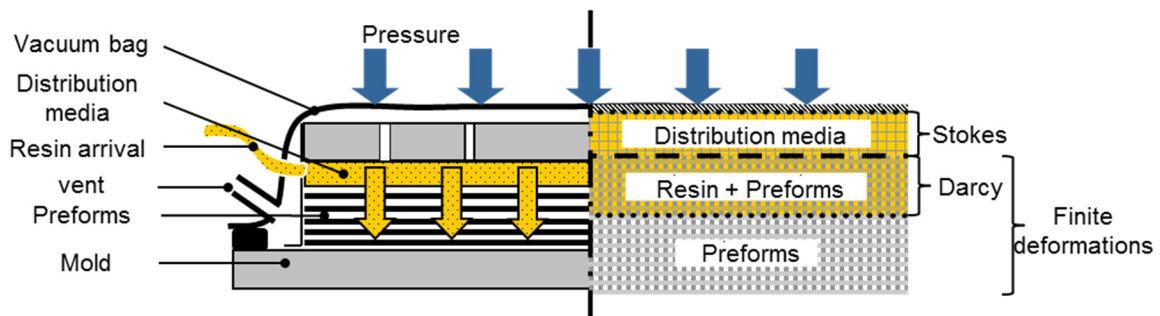

Figure 19: From P. Celle, PhD Thesis, École Nationale des Mines de Saint-Étienne, 2006.

Moreover, the method splits the process in four time periods:

- Pre-filling: Initial compaction of the preforms due to vacuum of the system (without resin).
- Filling: This phase starts when the resin inlet is opened and resin starts to flow.
- Post-filling: Re-compaction or “rest period” ended by the mechanical equilibrium which is mandatory to the dimensional quality of the final part.
- Curing (not studied here).

Figure 20 shows an example case for simulation of a 3D complex shape. One can identify a dry spot due to important initial compaction in low curvature zones.

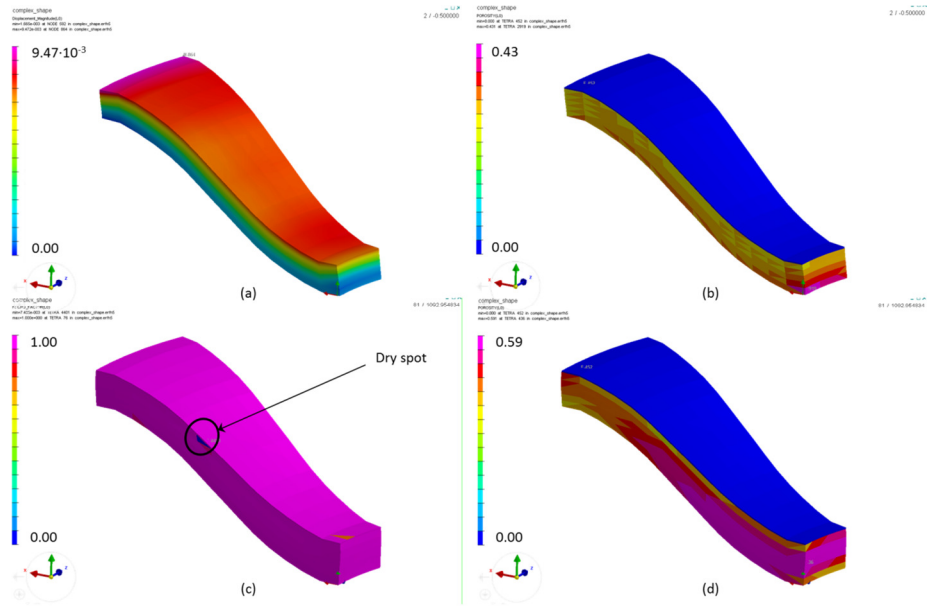

Figure 20: 3D complex shape simulation: (a) displacement field after initial compaction, (b) porosity (1-Vf) after initial compaction, (c) final filling factor, (d) final resin Vf

Pilot scale model validation experiments

The validation of INASCO sensors involved the design and manufacturing of a pressure setup capable to withstand more than 20 bar pressure, the design and manufacturing of four different types of sensor sealing-mounting configurations and appropriate experiments. A typical study to monitor resin arrival was the infused stiffened panel made by Bombardier Aerospace, Figure 21.

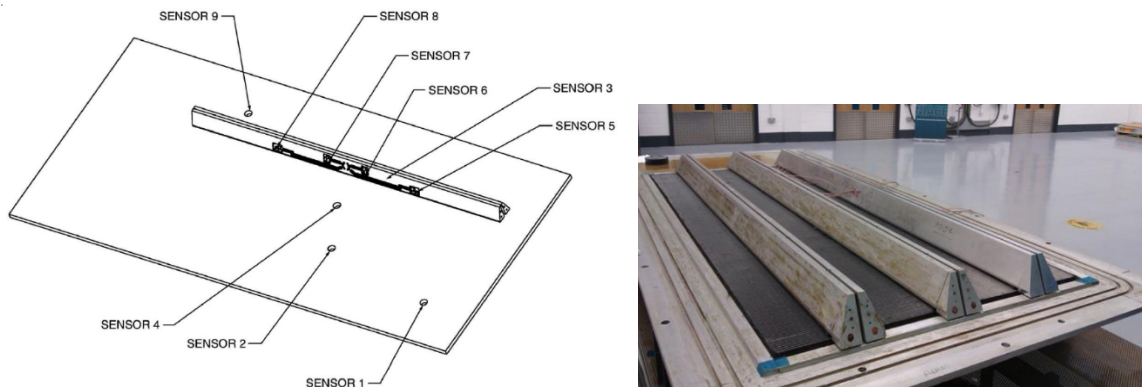

Figure 21: Sensor configuration for monitoring the infusion of a stiffened panel using INASCO flow sensors and DiAMON s/w.

Main results of the work package

Capillary flow:

- The challenge was to measure the capillary flow of epoxy resin within a carbon perform at 120°C inside an autoclave without the flow monitoring device disturbing flow advance. This was successfully achieved.
- The capillary pressure for a preform/resin system was measured in conditions very similar to LRI manufacturing conditions; it was found to be low for the fiber reinforcement/resin system

tested. Never-the-less the capability to simulate capillary pressure drop has been implemented in ProFlot at the macroscopic scale.

Stokes-Darcy analysis:

- A new model to simulate coupled Stokes-Darcy was developed and validated. An iterative process ensures the mechanical equilibrium between these two regions where the flows have been solved. Global convergence is sought through a residual for both flows.

Meshing Tools:

- New meshing tools have been developed specifically to help efficiently generate FE meshes for LRI simulation. The methods use 2D meshes as a starting point; these contain important data on material information such as location, thickness and number of plies. The tool can also handle layer drop off geometries and T joints.
- Generated meshes mainly use hexahedrons and pentahedrons for mechanical analysis. For injection or infusion analysis, tools are available to split elements into tetrahedrons.

CPU performance:

- PAM-RTM software now has DMP capabilities to simulate very large and complex industrial geometries requiring a detailed 3D mesh. Tens of millions of elements can be analysed.

Infusion-Compression:

- An LRI dedicated simulation code for injection-compression was developed within the ProFlot environment. The process simulation comprises of three main steps concerning Pre-filling, Filling and Post-filling and can properly treat finite strain deformations of the preform.

Sensors:

- The whole hardware (sensors, glands, toblorone, wires) was proved to work properly. There was no pressure loss and it was possible to transfer the signals from within the pressurized auto-clave environment to the DiAMon Flow™ system.
- All sensors were functional during the experiment and measurements from them were possible during the infusion experiment. The results show that the DiAMon Flow™ system & sensors do show events from the resin presence, even under the influence of carbon fibers.

Work package 6: Cost modelling and cost optimisation for LRI

Objectives

Cost models were elaborated for the different LRI processes in close collaboration with material suppliers and the project industrial partners.

1. The simulation tools infusion were considered in new costs modeling tools and procedures.
2. Process optimisation, with regard to the component manufacturing/part costs, were developed and verified.

Brief description of the work package

This work package investigated and undertook research into aspects of cost modelling and process optimisation:

- Cost analysis models were elaborated for the different LRI processes, in close collaboration with material suppliers and industry partners using an 'Activity Based Costing' (ABC) method
- A process optimisation with regard to the component manufacturing/part cost was developed and validated by UCR.

Cost Modelling

The Activity Based Costing (ABC), Figure 22, is a costing method that derives product costs as a sum of the costs of the activities that occur to make a product, either from a single process or from an entire production line.

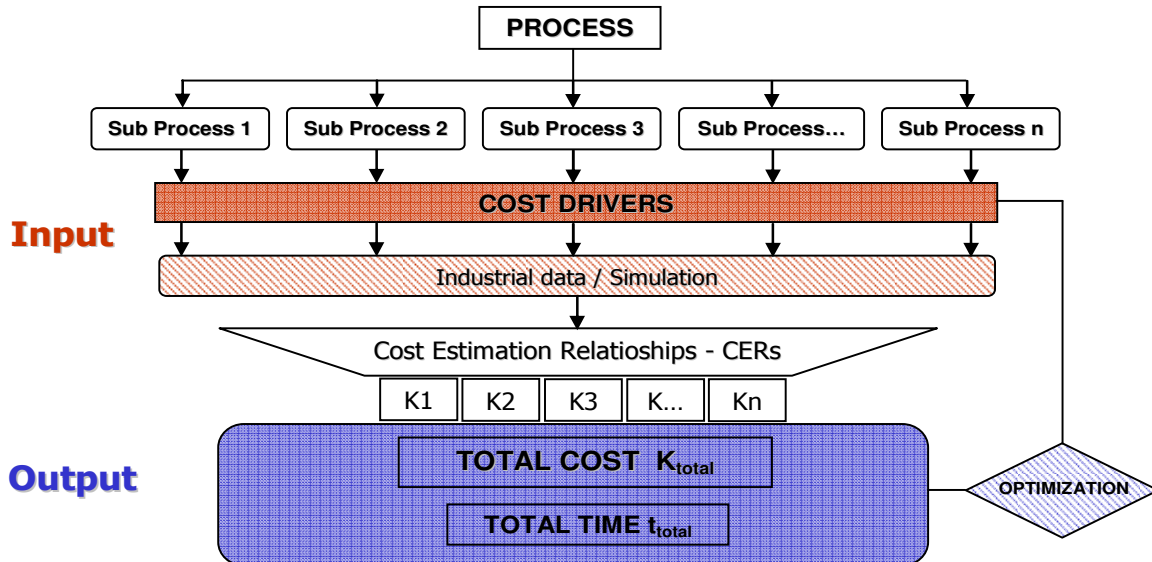

Figure 22: ABC methodology chain

The studies undertaken for cost modelling and validation are listed below. In each case a detailed cost analysis and Excel based solution was developed and provided to partners.

1. **Large Scale Demonstrator** – Centre Wing Box Upper Skin (*Bombardier Aerospace*)
2. **Large Scale Demonstrator** – G250 Fairing (*IAI*)
3. **Large Scale Demonstrator** – Belly Fairing Structure (*Piaggio Aero*)

Multi-objective optimisation with regard to process quality and cost

The aim of this activity was to integrate cost analysis within the process optimisation. Furthermore, since the developments within WP6 and WP8 were carried out in parallel, the scope of the optimisation capabilities was extended to include cure in the manufacturing process.

A Genetic Algorithm (GA) was adapted and used for these tasks. The GA accepts inputs such as the number of generations, the number of individuals in each generation, the reproduction and elite number, the size of the Pareto front, the number of the objectives, the number of the optimisation parameters and their ranges and the probabilities of cross over and mutation. An interface between the GA and the cost model developed in the project was specified and implemented. The cost interface provides the communication between Microsoft Excel, in which the cost model has been implemented by University of Patras, and the GA optimiser. The interface is used to write the input set for the cost model at the appropriate places defined by the user in the Excel spreadsheet. The structure of the interface is illustrated in Figure 23.

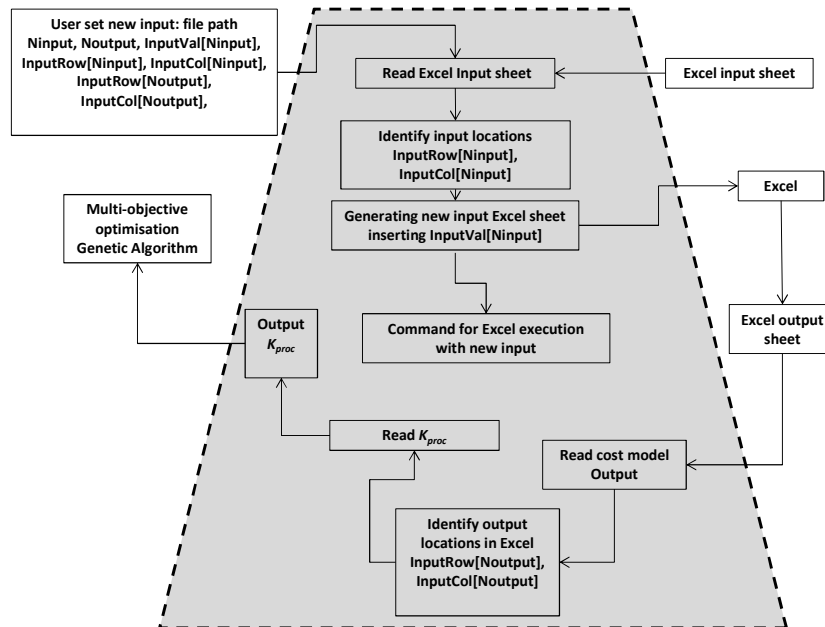

Figure 23: Structure of the interface between the cost model implemented in Microsoft Excel and the multi-objective optimisation GA.

Multi-objective optimisation necessitates communication of the GA with the infusion and process models. An interface for infusion simulation using PAM-RTM has been developed and an additional interface for communication with the MSC.Marc solver has been specified and implemented. The cure related optimisation is carried out by choosing an appropriate thermal cure profile applied during the process. The profile comprises two isothermal segments (dwells) and two dynamic segments (ramps) and is characterised by the two dwell temperatures the first segment duration and the ramp rate (r). The duration of the second dwell is fixed for simulation purposes; however, the interface allows interruption of the cure simulation once a predefined degree of cure has been reached signifying the end of cure. The time at which this occurs is used for the calculation of the actual process time, which is subsequently used in the execution of the cost model. The structure of the interface is adapted from the previous interface

The method and code developed were applied to cure of an industrial component. The component comprises a skin with three stringers. The optimisation problem was setup with the process design aiming at finding appropriate thermal profile variables (dwell temperature, duration of first dwell, heating up rate, convection conditions) that minimise cost and temperature overshoot. The part was considered to have a uniform initial temperature and initial degree of cure at the end of filling.

The evolution of the Pareto front during the GA run is illustrated in Figure 24. The multi-objective problem is relatively easy and the algorithm converges to a solution relatively quickly. The front has an L-shape, with an area where cost can be reduced significantly without affecting the exothermic behaviour and an area where the behaviour of the process becomes unstable with high risk of an exothermic event with minimal improvements in cost. Naturally a point close to the corner of the L-shaped front presents a good compromise between cost and performance/robustness. The final Pareto front of the optimisation is also illustrated in Figure 24, alongside the point corresponding to a conventional process. It can be observed that adopting a solution near the corner of the front results in significant cost reduction, close to 50%, at virtually no effects in terms of process temperature overshoot. This result clearly demonstrates the potential effectiveness of using multi-objective optimisation in the context of process design.

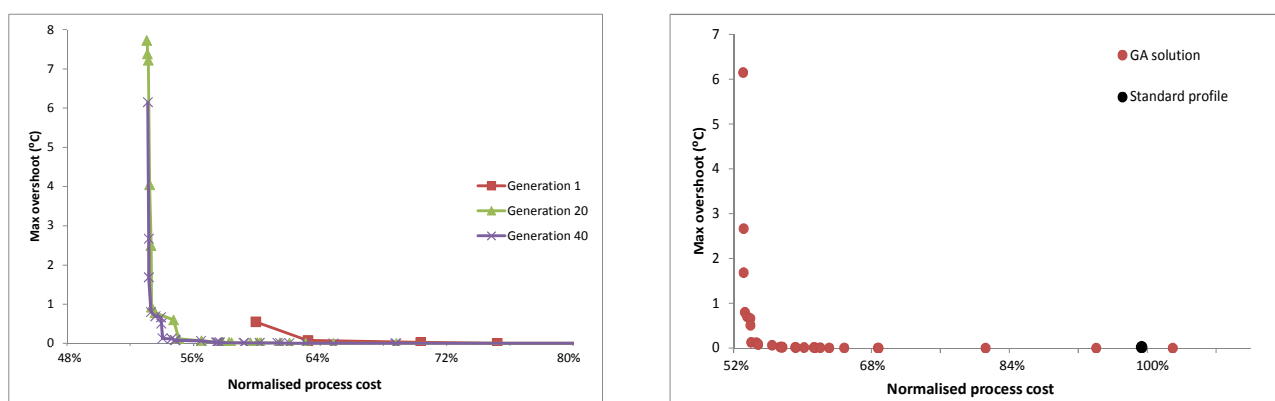

Figure 24: Evolution of the Pareto front in the cost/performance optimisation of an industrial component (left); comparison of the final Pareto front in the cost/performance optimisation and the standard profile (right).

Main results of the work package

Cost modelling

1. A systematic cost assessment of the manufacturing processes of the selected demonstrator parts was carried out using the ABC cost analysis concept. In this frame, a cost estimation analysis of the infusion processes was carried out using industrial cost data and process data.
2. The main results were estimation of total manufacturing cost and time for each of the demonstrator parts.
3. Each parameter's contribution to the total part cost and total process time was also calculated.
4. The major cost-and time-consuming sub-steps of each infusion process were investigated in order to identify and improve the critical sub-processes and their critical process parameters.

Multi-objective optimisation with regard to process quality and cost

1. Interfaces between the cost model developed by the University of Patras and the GA optimisation tool developed in WP8 and the cure models and the optimisation GA were specified and implemented.

2. Both interfaces are generic and allow use with modified versions of the cost and cure models.
3. The code was used to investigate multi-objective cost-temperature overshoot optimisation of and industrial case defined in WP9.
4. The optimisation resulted in very significant savings (in the order of 50%) with negligible effects in process performance.

Work package 7: Infusion and post infusion defects prediction

Objectives

Test and predictive numerical models for manufacture induced defects in LRI parts were investigated in order to predict the final part performance; including residual stresses, distortions and void content. The main types of defects treated were:

1. Thickness variations and degree of cure at the end of infusion.
2. Final part residual stresses and distortions.
3. Surface finish (feasibility study).
4. Voids and porosity distribution.

Brief description of the work package

The work package was divided into the following tasks:

- Integration of infusion and post-infusion curing simulations. Automated development of stress models including information from subsequent process steps:
 - Specification of infusion and post infusion simulation interface.
 - Code implementation of infusion-post infusion simulation interface.
 - Material models for cure simulation.
- Development of methodology for residual stresses and distortions leading to enhanced and tailored predictive models for residuals stresses in LRI materials:
- Prediction of the surface finish: Feasibility study to investigate if it is possible to predict surface finish using predictive models for residuals stresses.
- Characterisation of the effect of defects on product quality and how manufacturing defects affect final mechanical properties.

Background information:

Early in the project it was agreed upon that the experimental work will focus on two aerospace grade infusion resin systems. UCR developed and adapted chemical, thermal, mechanical and thermomechanical material sub-models required for the cure of fibrous composites for both resins. UCR also evaluated effects of defects such as residual stresses and porosity on the strength of the composite material. SIC have adapted their model to the results of the UCR models. Furthermore, SIC have characterized the mechanical properties one resin in both glassy and rubbery state, carried out RVE simulations and built explicit functions of homogenized ply properties required for simulations. The explicit expressions have then been used in simulations. SIC have also evaluated the possibility to use detailed cure simulations to predict surface defects. ESIF have been focusing

on the interface between the infusion simulations (PAM-RTM) and mechanical simulations using SYSPLY.

Integration of infusion and post infusion curing simulations

The development of a cure simulation requires the definition of numerous material sub-models that express the dependence of material properties on the current material state. In the majority of cure simulation studies the dependence of various properties on material state is ignored leading to significant inaccuracies in model results. The constitutive models required address chemical, thermal, mechanical and thermomechanical properties including cure kinetics, development of glass transition temperature, thermal conductivity, specific heat capacity, Poisson's ratios, mechanical moduli, coefficients of thermal expansion and shrinkage coefficients. The cure kinetics models are adaptations of published information, with evaluation of parameters based on data produced by Cranfield University in the project.

Thermal, mechanical and thermomechanical properties of the curing composite were modelled using the corresponding properties of the constituents and appropriate mixture or micromechanical laws. The changing state of the material during the cure does not allow the use of empirical relations; as a consequence purely predictive laws have been obtained. Once the law governing the mixing of resin and fibre properties is established the dependence of the constituents on the state variables of the systems is required. In the case of the resin there is potential dependence on temperature and degree of cure, which for a number of them is expressed as a function of material state. Fibre properties can potentially include dependence on temperature. In the models developed in this work the specific heat capacity and the thermal conductivity of the resin was considered as function of temperature and degree of cure, whereas the same dependence for the mechanical moduli, coefficient of thermal expansion and Poisson's ratio were assumed a function of the difference of current temperature to instantaneous glass transition temperature. Examples of the results of this type of models in the case of resin modulus and heat capacity are given in Figure 25.

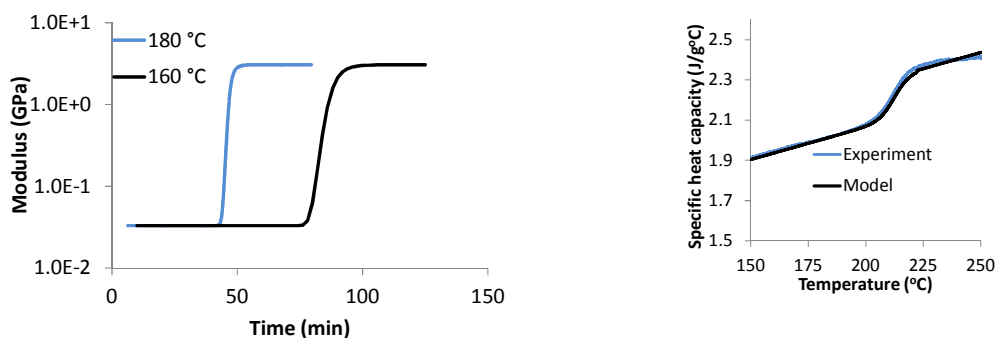

Figure 25: Examples of material sub-models: (left) development of modulus under isothermal conditions and (right) heat capacity as a function of temperature.

The heat capacity, thermal conductivity and coefficient of thermal expansion of the fibre were considered a function of temperature, whereas the mechanical moduli and Poisson's ratio of the fibre were assumed constant. The constitutive models developed are expressed in a set of 33 equations, involving 77 parameters that were estimated for the materials selected in this activity. The parameter estimation was based on both experimental data obtained in the project and results available in the literature.

This task also included the development of a seamless integration of infusion simulation with models of subsequent steps of the process. The focus was output of thickness and degree of cure spatial distributions and on developing a procedure for the automated generation of an appropriate process stress model. This involves the development of a link between infusion simulations and curing/distortion analysis. To achieve this, temperature and curing history information needs to be transferred from PAM-RTM to a SYSPLY distortion module as presented in Figure 26.

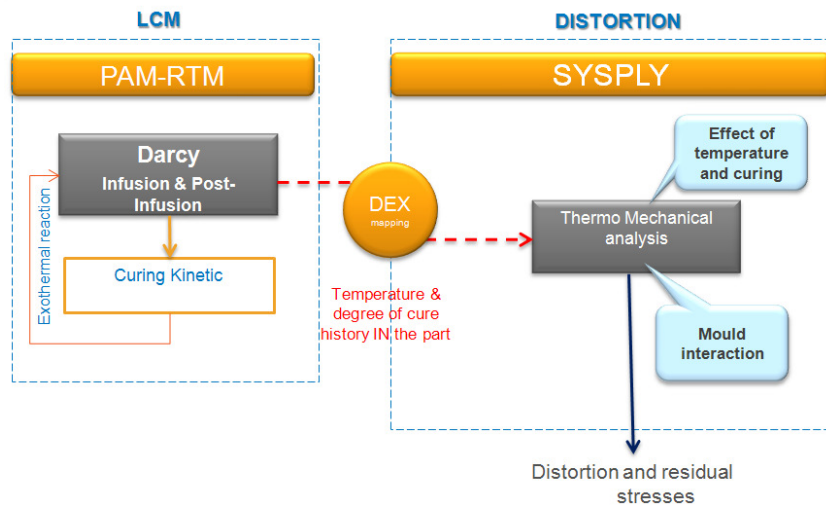

Figure 26: Data Workflow

An initial infusion simulation is performed to compute the part filling. Following this a post-infusion step is performed under a temperature cycle which will finalize cure of the part. After cool down the part is released and geometrical distortions will occur. PAM-RTM is used to compute thermal and curing field history in the part and SYSPLY uses this information as input for computation of the distortion. There is no meshing compatibility between PAM-RTM and SYSPLY. PAM-RTM uses tetrahedrons and SYSPLY uses pentahedrons as well as hexahedrons. In order to overcome this limitation a tool named DEX process is used map the data between the two mesh types. To achieve a correct link between PAM-RTM and SYSPLY, 3 steps of the existing DEX Process were updated to take account of these details:

Step 1 – Import module

The DEX Process uses an XML file format to transfer data from one module to the other.

Step 2 – Mapping module

The DEX Process was previously used for mapping results from 2D shell mesh to 2D shell mesh only. In order to establish a link between PAM-RTM and SYSPLY a new mapping algorithm for 3D elements was developed.

Step 5 – Export module

The temperature and degree of cure evolution in time are used in SYSPLY to compute Tg evolution in time to identify the materials phase. This information is stored in SYSPLY together with files for temperature (at nodes) and degree of cure (in elements). The automatic creation of these files during the DEX Process is necessary in order to capture the correct evolution of thermal and material properties so that distortion can be computed.

Development of methodology for residual stresses and distortions

An RVE of impregnated G1157 fabric was built as a cuboid with flat surfaces which implies that no nesting effects between plies is taken into account, Figure 27. Initial attempts with non-flat surfaces had to be abandoned due to difficulties of applying the correct boundary conditions. This yields the limitation that average fibre volume fraction of the RVE becomes quite low. Some different approaches for varying the fibre volume fraction were examined, but none of these approaches proved to produce an acceptable mesh quality for simulations. Therefore the fibre volume fraction is varied by scaling the RVE in the thickness direction and recalculating the mechanical properties inside the fibre bundles based on an assumption of constant fibre mass within the RVE.

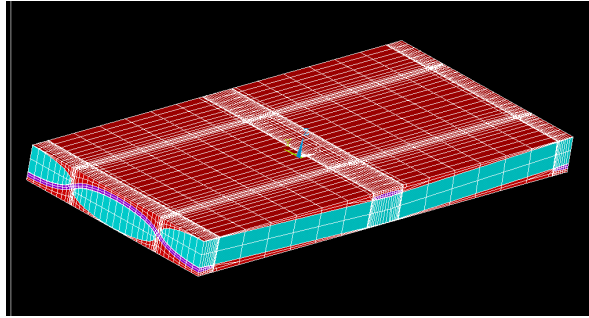

Figure 27: Cuboid RVE with flat edges.

Six load cases are required to determine the mechanical properties and two more load cases to determine the expansion coefficients of the RVE. These simulations resulted in homogenized mechanical properties of G1157 impregnated composite required for PID simulations evaluated at six different fibre volume fractions. This enabled fitting of explicit expressions describing all required properties as functions of fibre volume fraction. These functions are later used to determine the local mechanical properties based on the local fibre volume content.

Two feature level experiments were manufactured from material delivered from industrial partners. The first specimen type was an L-profile which is a common example when dealing with spring-in calculations. The second specimen type was a flat plate with a $[0_4, 90_4]$ -layup and a linearly varying thickness in one direction. This leads to a varying fibre volume fraction over the plate. Since the layup is unbalanced there will be a resulting curvature caused by the manufacturing induced stresses. This curvature is, in theory, affected by variations in fibre volume fraction which we aim to be able to capture in both the experiment and the simulation.

The measured spring-in of the L-profile is 1.03° . The corresponding simulated spring in is 0.88° . For the unbalanced plate three resulting curvatures were measured; namely, for the whole plate, for the thinner half and for the thicker half. The same curvatures are measured in the simulation and the results can be seen in Table 4. As can be seen the spring-in of the L-profile is underestimated and the spring-in of the unbalanced plate is overestimated by the predictions.

| | Predicted curvature (m^{-1}) | Measured curvature (m^{-1}) |
|---------------|----------------------------------|---------------------------------|
| Full specimen | 1.92 | 1.70 |
| Thicker half | 1.97 | 1.63 |
| Thinner half | 1.89 | 1.69 |

Table 4: Measured and predicted curvatures of the unbalanced plate.

Prediction of the surface finish (SIC)

This was a smaller task to explore surface defects prediction. First a small literature survey was undertaken on surface finish. Based on this it was assumed the only surface defect that might be possible to predict using the RVE and cure models is “print through”, i.e. surface waviness caused by the bundle structure. Laminates were therefore investigated to assess if the “print through” can be observed and predicted. From the micrographs, **Fehler! Verweisquelle konnte nicht gefunden werden.**⁵, no print through could be quantified or even observed at the surface. This implies that the print through caused by resin shrinkage is very small for these materials. From analytical considerations it was concluded that print-through is only of the order of a few microns.

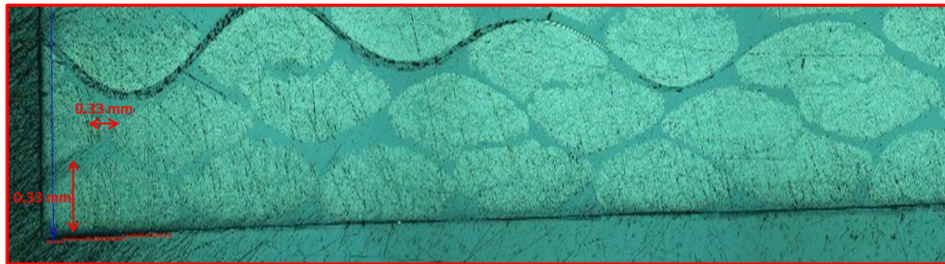

Figure 28: Typical micrograph of an intersection at the surface of the laminate.

Characterisation of the effects of defects on product quality

The effects of porosity on the flexural and shear damage response and of residual stresses on shear damage and delamination behaviour have been quantified. Different porosity levels in the 1-12% range have been generated by controlling process parameters such as the vacuum, resin injection type and backpressure and different ply residual stress in the 58-67 MPa range have been produced utilising different post cure temperatures. Figure 29 illustrates the effect of porosity on maximum shear strain and shear strength and the dependence of delamination toughness on residual stress. Porosity has a negative effect on flexural strength and shear properties whilst its effect on elastic response both in the undamaged and damaged states is negligible. The shear strength and the maximum shear strain decrease with the level of residual stresses whilst the energy release rate increases.

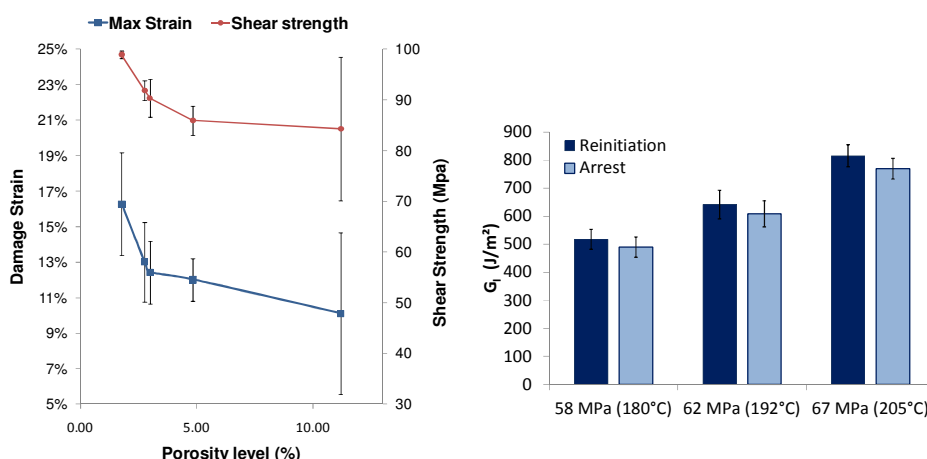

Figure 29: Effects of porosity on shear properties (left); effects of residual stress on delamination toughness (right).

Key results of these studies are listed on the following section.

Main results of the work package

Infusion and post infusion curing

- The chemical, thermal, mechanical and thermo-mechanical materials sub-models required for the cure of fibrous composites were adapted and developed for the project materials.
- The approach allowed dependence of properties on temperature and degree of cure.
- The models developed are appropriate for implementation in finite element solvers that allow state variables characterising degree of cure and have coupled thermo-mechanical capabilities.
- A methodology was developed for integrating results from infusion and curing simulations (PAM-RTM) with distortion simulation (SYSPLY).

Methodology for residual stresses and distortions

- A multi-scale modelling approach based on parameterized explicit functions fitted to results of RVE simulations was developed and tested for variations in fibre volume content.
- One resin system was successfully characterized for residual stress simulations.
- Geometrical characterisation of a laminate of G1157 reinforced composite, from micrographs, was successfully used to build an accurate RVE.
- Friction between moulding tools and reinforcement was characterised.
- One L-profile and one unbalanced plate with a varying thickness and fibre volume content was manufactured and measured. The measurement results were compared to predictions of shape distortions using the methodology developed in the task and acceptable results obtained.

Prediction of the surface finish

- A survey of surface defects that might be possible to quantify using detailed cure simulations was carried out. Fibre print through was deemed to be the defect with most chance to be predicted.
- Laminates were investigated in a microscope without being able to quantify any print through.
- An analytical study showed that any print through caused by the cure is very small or negligible.

Effects of defects on product quality

- Porosity was found to reduce compressive, tensile and inter-laminar strength of unidirectional laminates with sensitivity in the range of 4-10% per 1% additional void content. Process stress can be detrimental, or beneficial, for tensile and compressive properties depending on the direction of the stress in comparison with the direction of loading.
- The flexural strength of fabric composites decreases by 1% per 1% additional void content following a non-linear dependence, whilst the in-plane shear strength decreases by approximately 1-2% per 1% increase in void content.
- Shear strength decreases with increasing process stress; the sensitivity of this dependence is slightly over 1% per 1% increase in stress.
- The delamination response is improved by the presence of compressive stress at longitudinal fibre interfaces; this positive sensitivity reaches values of about 5% per 1% increase in process stress at the ply level.

Work package 8: Process optimisation

Objectives

This task developed process optimisation methods to assist the process designer to determine the 'best' process setup. Single and multi-objective optimisation techniques were established and integrated with the infusion simulation code; which allowed exploration of the process design space, identification of optimal process designs and investigation of the trade-offs in process design to be carried out. The optimisation routine was also utilised to achieve the integration of modelling results with monitoring allowing an on-line estimation of unknown properties such as fabric permeability.

Brief description of the work package

This work addressed the development and adaptation of a multi-objective optimisation methodology based on genetic algorithms for the design of the infusion and cure stages of processing and the development of a scheme that combines modelling and monitoring in an inverse scheme for the on-line adaptation of process simulation.

The developments were carried out in parallel with activities in WP6 on optimisation taking into account process costs. The optimisation tool equipped with the interface and cure simulation capabilities developed in WP6 was applied to the cases of multi-objective design of infusion and cure for process optimisation. The inverse scheme addressed the combination of flow monitoring with infusion process simulation using a code combining an interface with PAM-RTM and the GA algorithm. The methodology was applied to the case of two dimensional flow using artificial monitoring data.

Process optimisation

The Genetic Algorithm from WP6 was adapted for the purpose of the optimisation work in this work package. The original implementation was adapted by enhancing the management of the Pareto set by implementing the following changes:

- (i) The normalised distance calculation between individuals was modified to allow for cases where an objective has a value equal to zero by adding an infinitesimal number to the denominator of the normalised distance formula in these instances.
- (ii) The comparisons between individuals were modified to exclude the comparison of an individual with itself.
- (iii) The case of a full Pareto set was modified to replace individuals based on the distance metric with the aim of preserving individuals with the lowest sharing rank.

An interface was developed for exchange of process design parameters and objective values between PAM-RTM and the multi-objective optimisation GA. The structure of the interface is illustrated in Figure 30.

The GA produces a set of parameter values for the process design (dwell temperatures, segment durations, number and locations of gates) which are fed directly to the interface. The interface reads a PAM-RTM input and the locations in the PAM-RTM input file where the process parameter values are inserted are identified. Subsequently, a new input file is generated with the parameter values output by the genetic algorithm replacing the nominal parameter values in the PAM-RTM input template. A command for the execution of PAM-RTM using the new input file is generated and run using a script file. The output file of PAM-RTM is opened and read. The locations in the output file

where the quantities of interest (filling time, degree of cure at the end of filling) are placed are found and these quantities are read. The outputs are then sent to the GA.

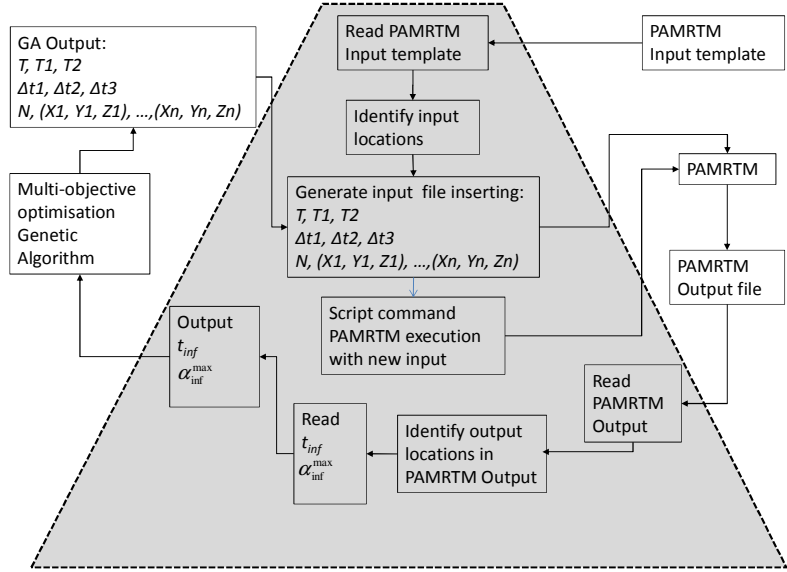

Figure 30: Structure of the interface between PAM-RTM and the multi-objective optimiser

The optimisation of the filling stage of infusion involves the definition of characteristics of the thermal profile (dwell temperatures, dwell durations and ramp duration) as well as the inlet location. This is based on a new concept of designing the profile used to achieve an efficient compromise between process duration and degree of cure at the end filling in way that speeds up the process without risking over-cure and the failure of the process. The capabilities of the optimisation methodologies were demonstrated on a simplified version of Piaggio test case, which was investigated in WP9. The modelling domain, which is a two dimensional representation of the full test case, is illustrated in Figure 31. The component is a skin with a C-stiffener.

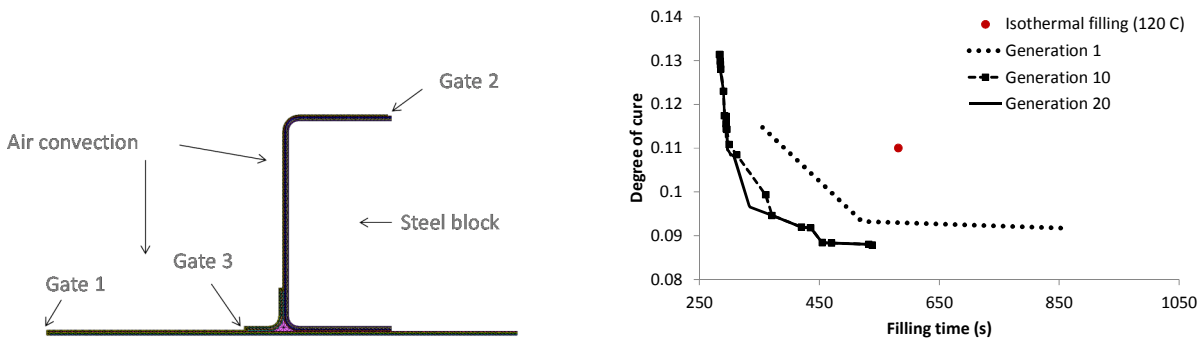

Figure 31: C-section model built in PAMRTM (left); evolution of the Pareto set (right).

The optimisation involved seven parameters, six continuous (parameters of the thermal profile) and one discrete (inlet location). Figure 31 illustrates the results of the multi-objective optimisation depicting the Pareto front at different generations, alongside the results of conventional filling. The GA is able to approach the final Pareto set successfully showing a high rate of convergence, within

10 generations, which corresponds to 150 PAMTM executions. Standard LRI infusion is used with isothermal filling in which the tool plate is kept at 120 °C and the resin is injected at 80 °C. The standard infusion has a filling time of about 580 sec and a final degree of cure equal to 0.11. The L-shape of the final Pareto set suggests a preferential region around the corner that allows to improve both filling time and degree of cure. Furthermore, it indicates the existence of two distinct zones, the horizontal part and the vertical part. In the horizontal part it is possible to achieve significant improvement in filling time with small effects in the final degree of cure, whereas in the vertical part the final degree of cure changes significantly for small improvements in filling time. The standard infusion point is away from the Pareto set indicating inefficiency of the current process setup. It is possible to achieve a 40% reduction in filling time and a 15% reduction in final degree of cure by choosing a design point at the corner of the Pareto set.

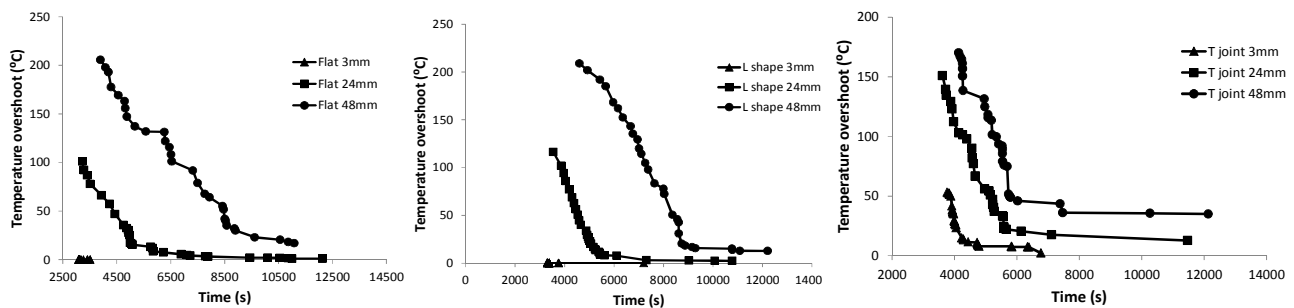

Figure 32: Temperature overshoot – cure time trade off surfaces identified by optimisation: (left) flat panel; (middle) L-profile; (right) T-joint.

The cure optimisation capabilities have been demonstrated with an investigation of the curing of three generic features of composites components: (i) a flat panel; (ii) an L profile; and (iii) a T-joint. Three thicknesses were considered for each of representing thin, thick and ultra-thick laminates (3 mm, 24, mm and 48 mm). The results of the nine optimisation studies are summarised in Figure 32. The Pareto front in all cases has an L-shape comprising an area in which it is possible to obtain significant reduction in overshoot with small benefit in process duration and an area in which there are significant improvements in process duration and small benefits in overshoot reduction. It should be noted that conventional cure profiles are mainly in the low sensitivity overshoot region. A selection around the corner of the trade-off surface leads to significant improvements compared to conventional cure profiles.

Modelling-monitoring integration

The inverse scheme developed concerns the use of on-line measurements for the estimation of permeability by minimisation of difference between model results and monitoring. This integration of modelling and monitoring overcomes the accuracy limitations of simulation due to uncertainty in properties and the limitations of monitoring caused by its local character. The on-line estimation combines the benefits of both. On-line monitoring allows estimation of the actual permeability of the fabric involved in the manufacturing process, whilst modelling translates the local measurement to a global picture of the flow in the component. The development addresses the process of composite infusion in which three permeability values are considered as unknown. An interface links the GA developed in the project, the Proflot library of PAM-RTM which performs the solution of the flow through porous problem and Cranfield Measurement and Control (CMC) which is a Labview code that

is utilised for general monitoring purposes and in this case provides the output of the spot flow monitoring dielectric sensors.

The domain of the inverse solution for the case of a flat panel infusion is shown in Figure 33. The infusion stack comprises the fabric and a porous medium that enhances resin flow. The inlet is usually place on the side of the porous medium.

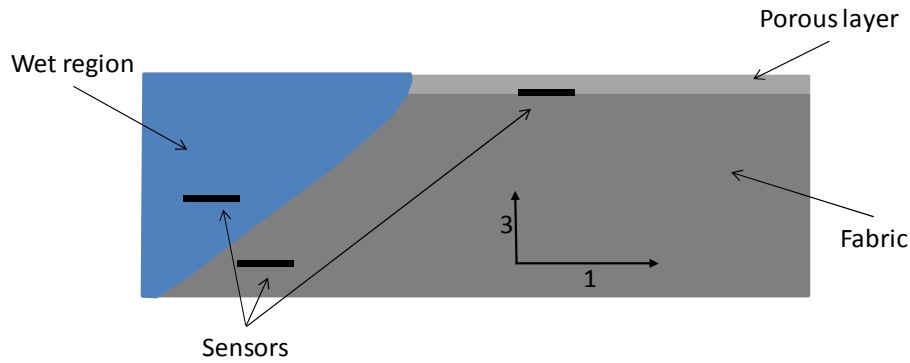

Figure 33: Domain of the inverse problem in the case of a flat panel infusion.

The problem addressed is two dimensional with one direction through the thickness and one in plane. The fabric is considered anisotropic, with different permeabilities in the through thickness and in plane directions, whereas the porous medium is isotropic. An array of spot sensors is incorporated in the assembly; the particular sensors used in this development allow a measurement of impedance. Upon resin arrival the impedance signal shows an instantaneous drop which will be used for identifying the time the flow front reaches the sensor. The inverse problem is cast as the minimisation of the absolute difference between resin arrivals as identified by the sensors and as computed using the Proflot simulation. Three variables are estimated based on the minimisation of this difference namely the longitudinal permeability, the through thickness permeability, and the flow media permeability. The interface is utilised for the exchange of unknown variables (permeabilities), the minimisation objective and monitoring results between Proflot, the inversion GA and the monitoring set up. The structure of the interface is illustrated in Figure 34.

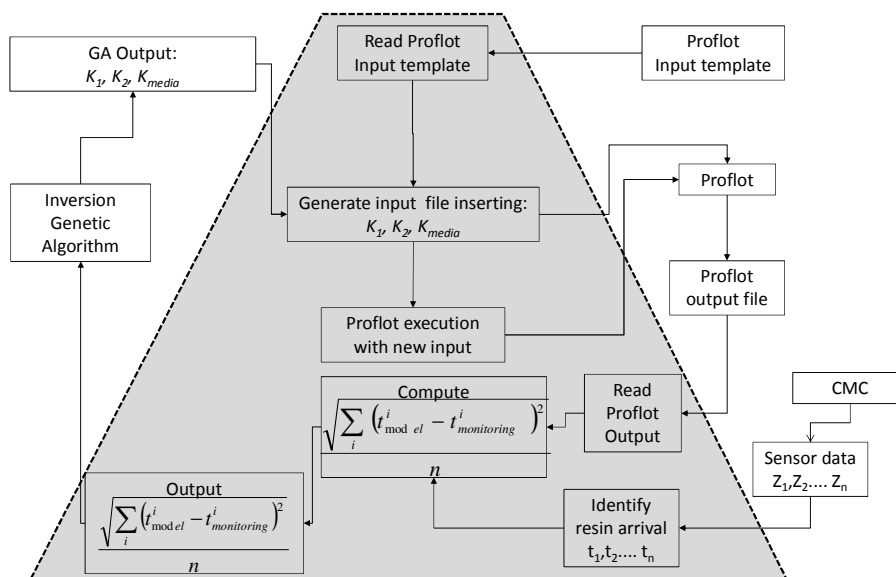

Figure 34: Structure of the interface between Proflot, the inversion GA and CMC

The

inverse scheme was applied to the case of a 2D section of a 30 mm thick flat panel using artificial noisy data of sensor resin arrival times. The fabric is covered by a flow medium which is placed centrally. An area of the fabric stack is left uncovered close to the edges. Resin is injected centrally and uniformly in the depth direction. This injection strategy results in a two dimensional representation of the problem and symmetry along the centreline of the domain. The performance of the scheme has been tested for three different levels of noise in arrival times: 5 s, 13 s and 25 s. The GA was executed for ten generations. The values utilised for the noisy data were obtained by drawing random numbers for a normal distribution with standard deviation equal to the corresponding noise levels. Thirty realisations were used for each noise level. In general it has been found that estimation of fabric permeabilities is highly robust, whereas that of the porous media more challenging. Figure 35 illustrates the convergence of the average among the 30 realisations behaviour for the three noise levels.

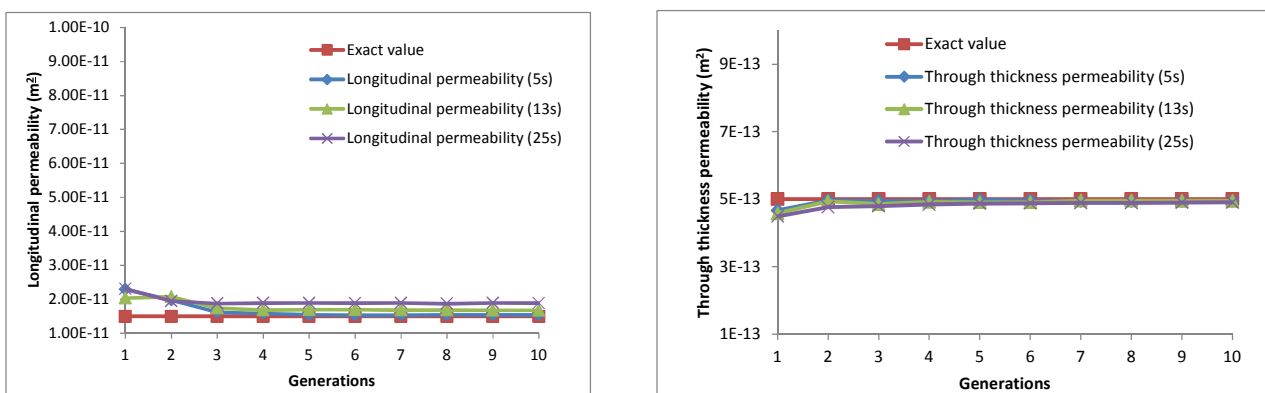

Figure 35: Average permeability convergence: (left) Longitudinal permeability; (right) Through thickness permeability.

Main results of the work package

- An interface between infusion simulation and a multi-objective optimisation Genetic Algorithm was specified and implemented. The interface is specific to the multi-objective optimisation tool used and PAMRTM with the potential for extension to other codes.
- The genetic algorithm multi-objective optimisation process and corresponding simulation interfaces was used successfully for the design of infusion filling and cure.
- The filling optimisation can be used to determine an appropriate thermal profile and inlet location. The GA approximates accurately and efficiently (at 4% of the computational time required for an exhaustive search) the Pareto set of the filling optimisation.
- The Pareto set uncovered contains potential process design that result in significant improvement in both process time (40%) and degree of cure (15%) at the end of cure in comparison to conventional infusion conditions.
- Cure optimisation can be used to select an appropriate thermal profile in order to minimise process duration and the risk of an exothermic event. The GA provides an accurate and efficient (25% of the effort required for an exhaustive search) solution of the cure optimisation problem.
- Significant cure process duration reduction (up to 60%) and temperature overshoot (up to 80%) compared to a conventional cure profile can be achieved using the GA multi-objective optimisation.

- An interface for the modelling-monitoring integration through an inverse solution was specified and implemented. The inverse solution targets the minimisation of differences between modelling and monitoring results by altering the permeability values of the fabric and the flow media.
- The inverse scheme developed has been used for estimating the fabric and flow media permeability successfully using the artificial response of three sensors.
- The scheme obtains the correct solution for fabric permeabilities up to the highest noise level tested (25 s).

Work package 9: Application and validation

Objectives

- This WP undertook industrially relevant test and CAE studies with the four end-users to validate and help develop the new CAE tools and research developments.
- Each end-user applied different LRI processes and materials which helped ensure generality of the project developments.
- Industrial studies covered both preforming and infusion; with studies being progressively more complex as the project progressed.
- Some specific tasks were also dedicated to training and knowledge transfer.

Brief description of the work package

Generally, the tasks are structured to apply and evaluate new developments as they become available, according to the following structure:

- Year 1 Limited problem specification work and knowledge transfer.
- Year 2+ Drape analyses using new developments in the draping FE code and simple infusion studies.
- Year 3+ Advanced drape and infusion studies using the improved software version.
- Year 4 Coupled drape/infusion and additional process optimisation, costs analysis and process defects analyses.

The following descriptions briefly outline studies undertaken by the consortium at each of the industrial partners.

DAHER demonstration activities

The first experiments and simulations were performed on spatial tubes and small I section beams. DAHER then built a complete test program to study infusion and evaluate simulation tool performance; this test program consisted of three steps:

1. Study of preforming operation on chosen simple geometries for preforming singularities.
2. Study of impregnation by infusion on chosen simple geometries for infusion singularities.
3. Study of a 2,5m long wingbox spar demonstrator.

Each subject was studied using the same methodology:

- Manufacturing of singularities with different process options.
- Simulation of the same option.
- Comparison between experimental results and simulation.
- Selection of configuration to monitor (for infusion only).
- Comparison between monitoring results and simulation (for infusion only).

The simulation work was undertaken in collaboration with ARMINES and ESI Group.

Example study on infusion singularities

Figure 36 summarises one study undertaken for the panel with T stiffener singularity. Conclusion regarding this singularity test did show differences between test and simulation. It was necessary to have a good practical understanding of the process in order to create a representative simulation model; never-the-less the simulation was valuable to understand strange behaviours.

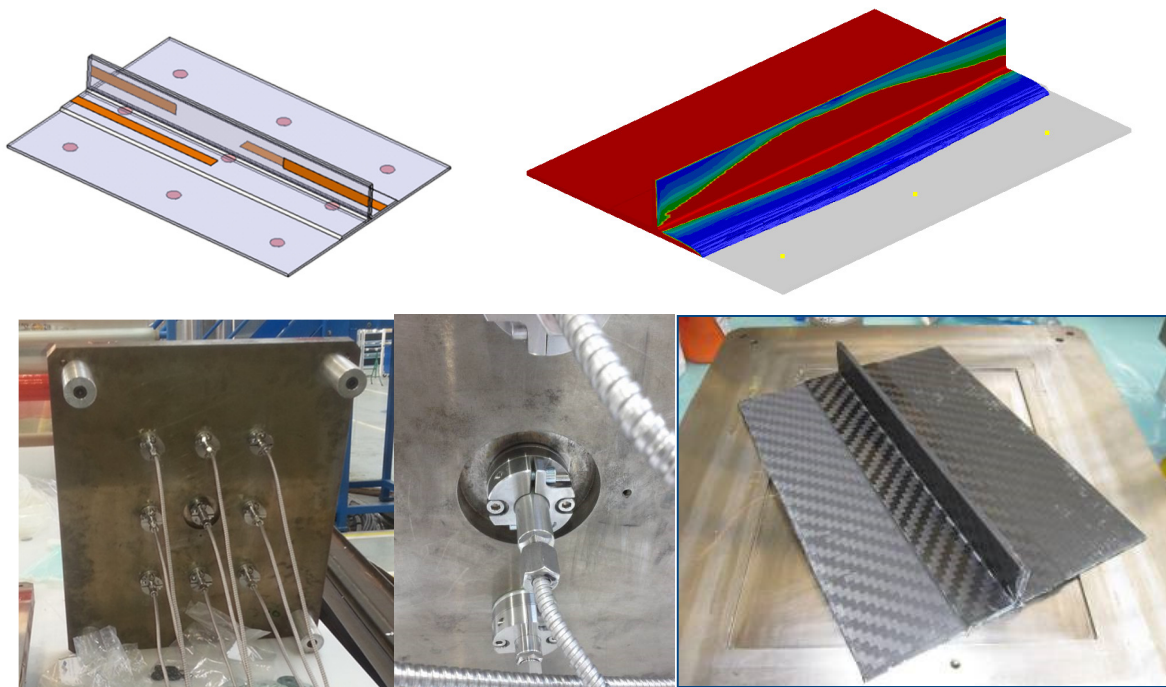

Figure 36: DAHER small scale singularity (panel with T stiffener)

Large scale demonstrator

The (final) large scale demonstrator was a 2,5m wing box spar, Figure 37. The main aims of the study were:

- To provide a challenging experimental trial on an industrial level geometry for the LRI simulation.
- Two spars were manufactured:
 - 1st to test manufacturing and capability of the simulation to help choose the infusion strategy.
 - 2nd spar using a modified strategy from improved simulations and feedback from the 1st test infusion monitoring.

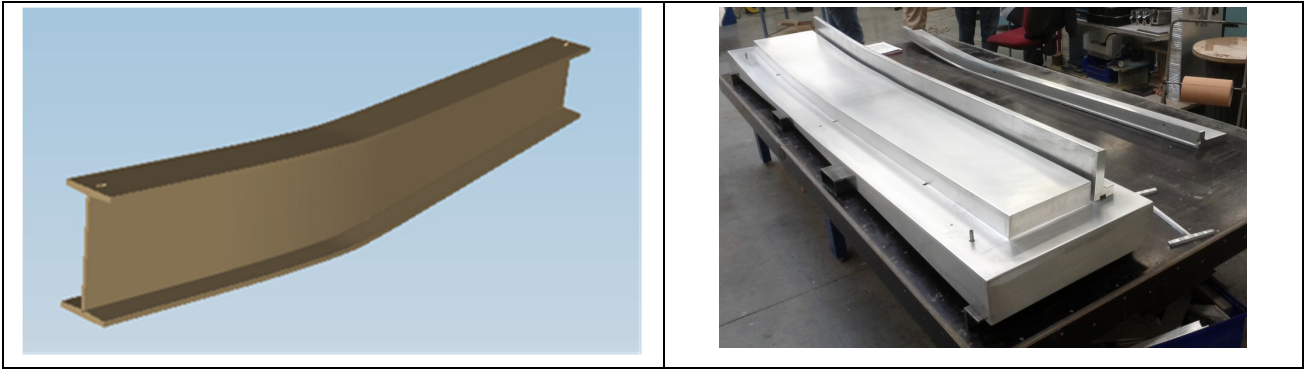

Figure 37: DAHER large scale demonstrator 3D CAD and tooling

Example LRI simulation results for the Daher Spar are shown in Figure 38. The following conclusions were drawn from this study:

- Infusion setup benchmark:
 - Simulation is a powerful tool to compare several scenarios and to understand filling of the part (define vents, injection points, filling time).
- Infusion issue understanding:
 - Capability to identify the origin of defects or poor impregnation.
- Full process simulation:
 - Currently for prototype and idealized geometries.
 - Can be difficult to integrate real industrial issues (e.g. race tracking)
 - Complex manage idealized model versus real industrial manufacturing
- Industrial needs include:
 - Database for material permeabilities, viscosities and ancillary data
 - Expertise in meshing for software specific needs
 - Expertise in fluid mechanics to define boundary conditions (pressure, flow rate...)
 - Expertise in process manufacturing

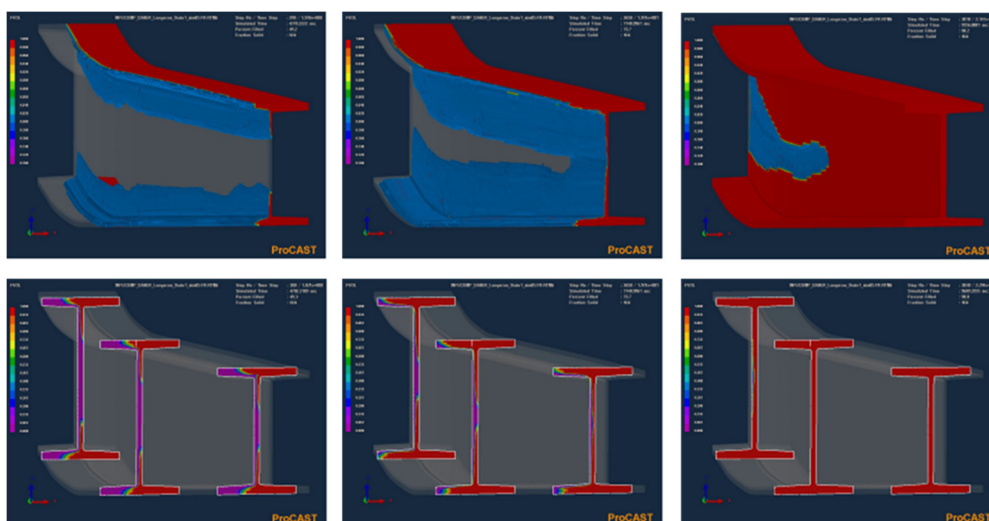

Figure 38: Example DAHER spar simulation results

Piaggio Aerospace: Demonstration activities

Piaggio performed studies on small scale C-stiffeners, panels and a final year belly fairing structure.

Mechanical characterization on small scale demonstrators

Mechanical characterizations have been performed on coupons extracted from the small scale demonstrators. The purpose was to generate a database that will help to optimize design and stress analysis of infused structures.

Small scale demonstrators

The first infusion studies considered small scale demonstrator parts, Figure 39, which were manufactured using LRI. ESI GmbH and IFB both used these experimental studies to help validate the software and new code developments.

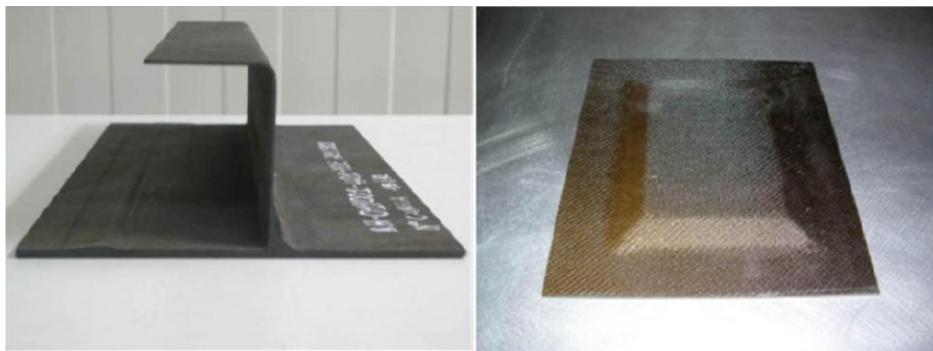

Figure 39: Piaggio small scale infusion demonstrators (C stiffener monolithic demonstrator and sandwich demonstrator)

This tests allowed two ultrasonic NDI methods to be evaluated:

- Encoderized Ultrasonic Pulse Echo (EUPE)
- Ultrasonic through Automatic Transmission (AUTT)

Figure 40 shows example non-destructive inspection results for the small scale sandwich demonstrator.

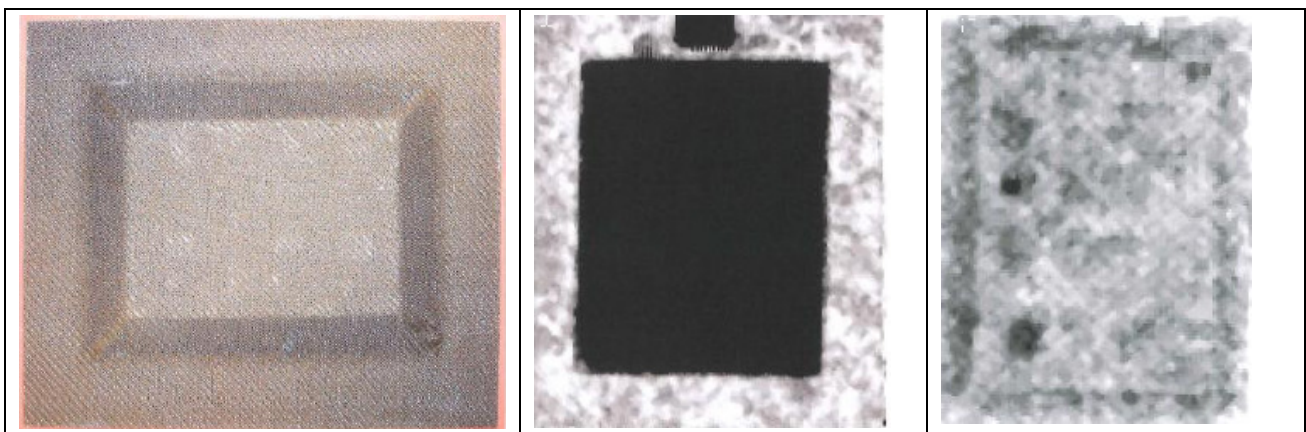

Figure 40: Sandwich small scale demonstrator (a) and artificial defect distribution, C-scan monolithic area (b) and sandwich area (c)

Belly fairing large scale demonstrator

The final year studies consider the complex infusion of a belly fairing structure, which comprises of sandwich panels, skins and C-spars, Figure 41. A design was performed and included the following tasks:

- Finalization of the infusion tool design
- Infusion tool provision
- Infusion strategy study
- Infusion monitoring session preparation in collaboration with INASCO
- Infusion strategy optimization in collaboration with ESI GmbH

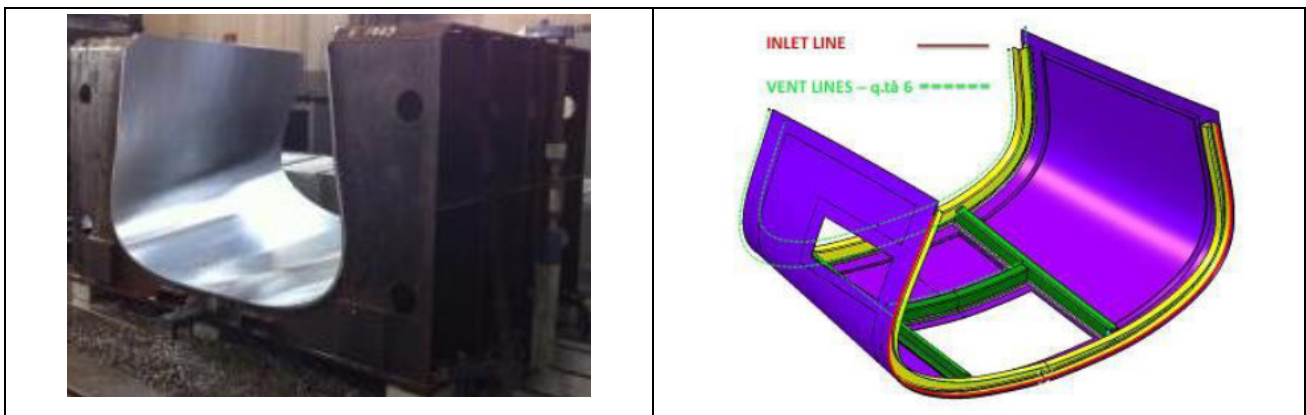

Figure 41: Belly fairing demonstrator

The following pictures shows the tool and means necessary for infusion of the belly fairing demonstrator, Figure 42.

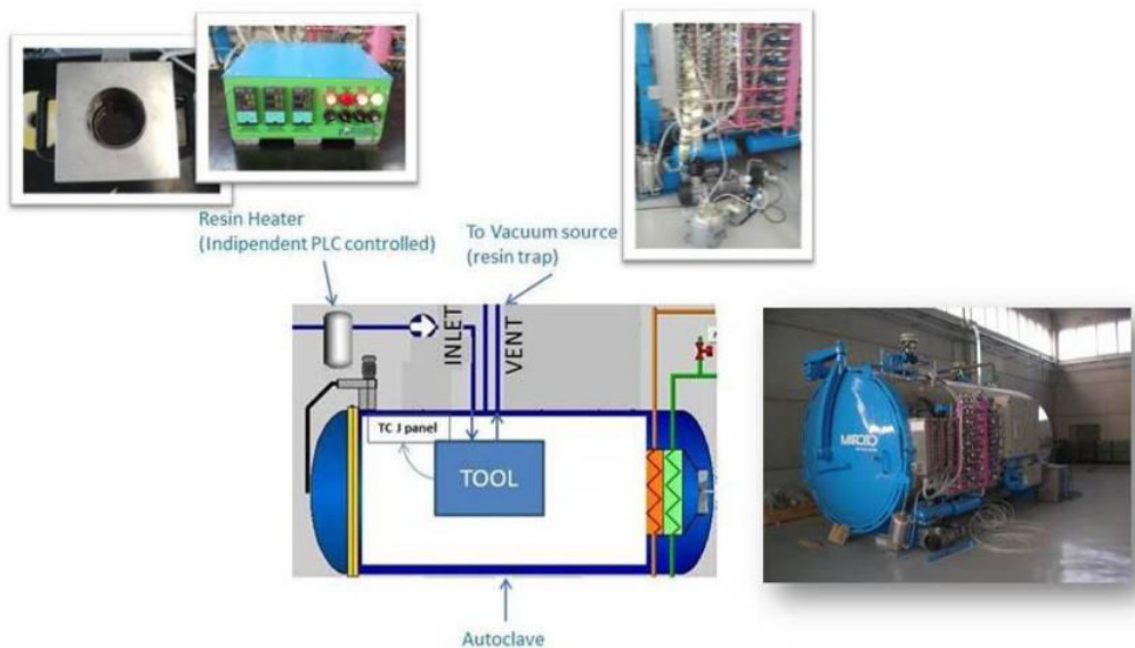

Figure 42: Piaggio infusion test setup

Bombardier Aerospace: Demonstration activities

Preforming simulation tool evaluation

Preforming test and simulations of a spar were conducted, Figure 43. Generally, the simulation worked well, but some detailed wrinkling, as found in the tests, were not able to be fully captured. Future work should consider further model refinements, slower loading, and improved representation of the test set-up.

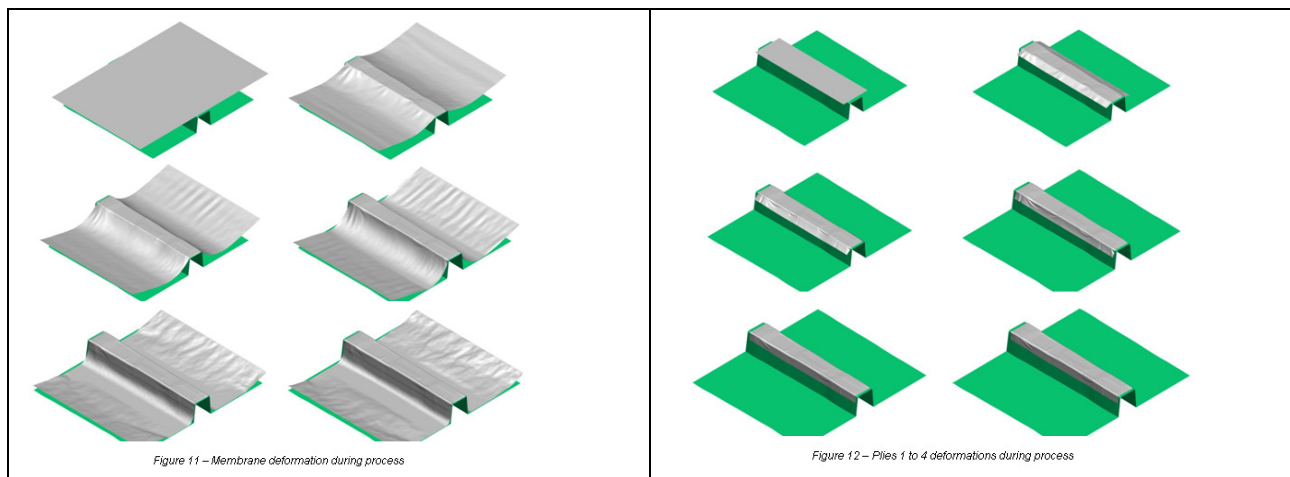

Figure 43: Bombardier preforming studies

Infusion trials and simulations

Numerous demonstrator infusion studies were conducted by Bombardier throughout the project. Figure 44 shows one example concerning the final year test study with example simulation results shown in Figure 45.

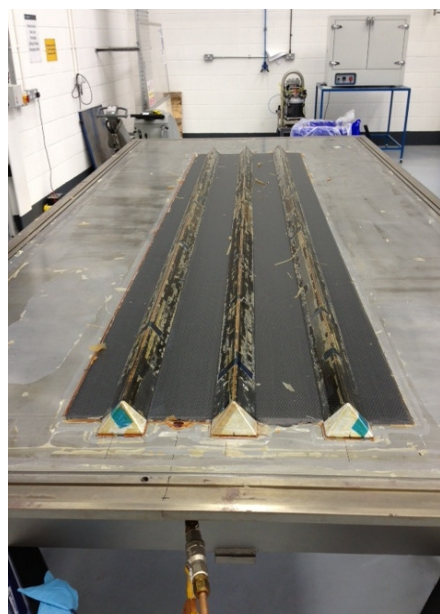

Figure 44: Cured Final demonstrator just after cure on the rigid bottom tool

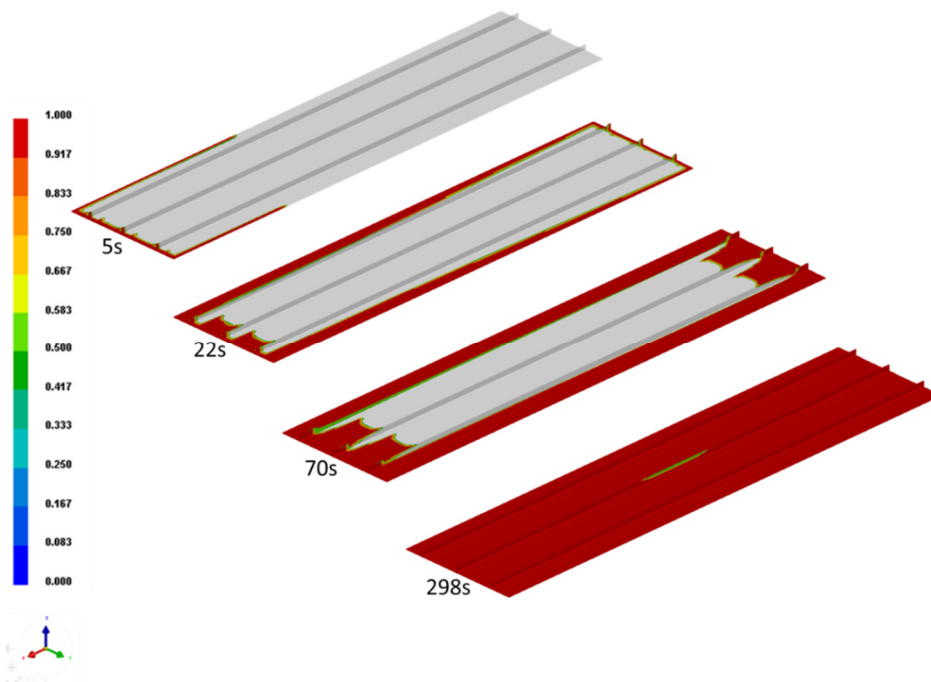

Figure 45: ESI Flow front simulation

Some differences have been noted between test and simulation infusion times and ongoing work, after the project, will further investigate these differences. In particular the relevant partners are following up on these results to emphasise the thickness change of preform due to the nature of the semi-rigid bag tool and its allowance of resin build ups during the early stages of wet-out.

Israel Aerospace Industries: Demonstration activities

Infusion study 1 – The IAI fairing

The IAI fairing part was simulated with PAM-RTM and results compared well to tests; however it was noted that this fairing is not particularly challenging from the injection point of view. Example simulation results are shown in Figure 46.

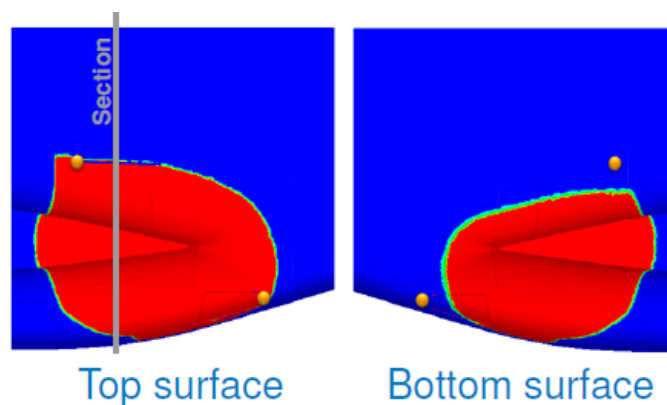

Figure 46: Distribution media effect on a 3D infusion simulation

Infusion study 2 – Lateral wing box skin

This demonstrator is a lateral wing box skin like structure that consisted of an infusion skin with pre-cured stringers bonded via adhesive film. The objectives of this simulation were:

1. Prediction of flow front below the cured stringers.
2. Determine optimum time to open next injection lines.
3. Scale up to 8 meter length.
4. Determine optimal length of injection line and distribution net to avoid race tracking.
5. Thickness effects goals and challenges.

IAI collaborated with ESIG to simulate infusion of the demonstrator; the main purposes were:

- To benchmark infusion strategies.
- To optimise infusion strategies.
- To identify interaction between the pre-cured stringers with the infusion of the wing box skin.

Manufacture of the system is shown in Figure 47.



Figure 47: Wing box skin process flowchart part 2

The study of the wing box skin, did successfully identify potential risks concerning a filling behaviour between the stiffeners that may generate air entrapment, Figure 48.

Infusion study 3 – Air entrapment

In order to the challenge simulation code and developments coupons were defined in order to be used to test and model race tracking behaviour. Simulation and coupons have been analysed in parallel in order to have a better understanding of this phenomenon and study some infusion strategies that may help avoid it, Figure 49.

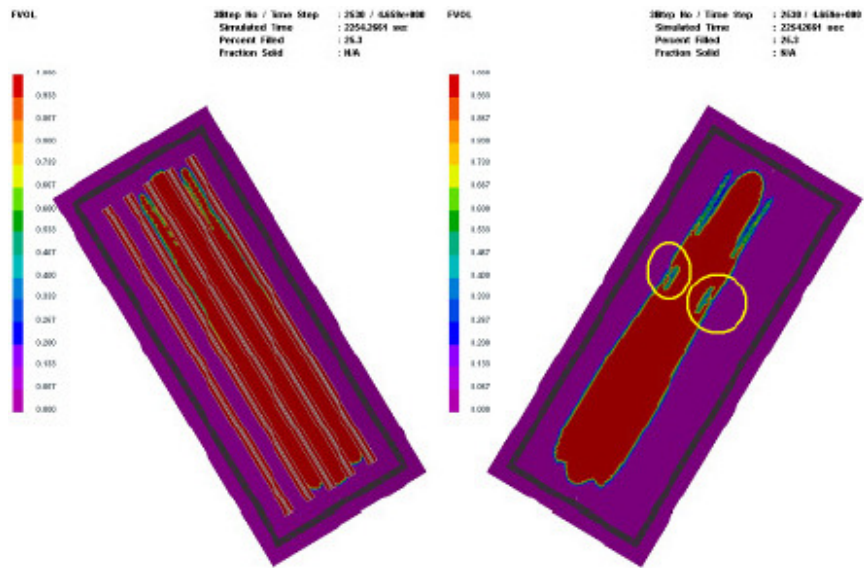

Figure 48 IAI demonstrator – entrapment phenomenon

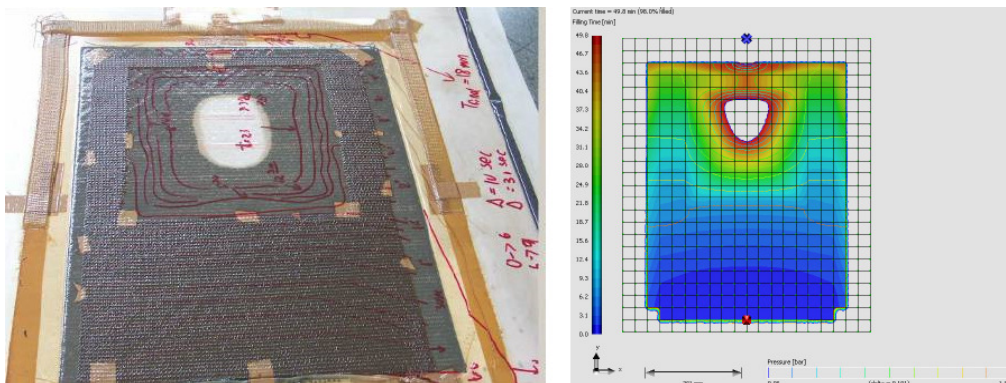

Figure 49: IAI Entrapment coupons and simulation

Monitoring of large scale processing

INASCO has provided support for the monitoring of industrial demonstration activities.

INASCO main contribution was to bring monitoring expertise to the demonstrator studies and to assist industrial partners. In particular this covered:

- Monitoring scenario advice.
- Interface between monitoring system and infusion set-up including compatibility with monitoring inside autoclaves.
- To investigate new monitoring technologies for preform thickness measurement during infusion.

1.4 Project website and logo

A website has been completed and was agreed by all partners. It is up-to-date for the end of the project (September 2013). This website is maintained by the ESI Group website manager and is located at:

<http://www.esi-group.com/corporate/alliances/projects/INFUCOMP/INFUCOMP>









The project logo is:























































2. Use and dissemination of foreground













































Section A (public)

















































































LIST OF SCIENTIFIC (PEER REVIEWED) PUBLICATIONS































| Project Publications (Peer reviewed publication) | | | | | | | | | | | | | |
|--|----|--------|--|--|---------------------------------------|---------------------------|-----------------------|----------------------|---------------------|----------------|---|-----------|---|
| Order N° | N° | D.O.I. | Title | Author(s) | Title of the periodical or the series | Number, date or frequency | Publisher | Place of publication | Date of publication | Relevant pages | Open access is/will be provided to this publication | Status | Actions |
| | 1 | | Unit cell modelling of textile laminates with arbitrary inter-ply shifts. Composites Science and Technology | Ivanov, D.S., S.G. Ivanov, S.V. Lomov, and I. Verpoest | Composites Science and Technology | 72(1) | Elsevier BV | | 01/01/2011 | 14-20 | No | VALIDATED |   |
| | 2 | | Meso-level textile composites simulations: open data exchange and scripting. Journal of Composite Materials | Lomov SV, Verpoest I, Cichosz J, Hahn C, Ivanov DS, Verleye B. | Journal of Composite Materials | 1 | SAGE Publications Ltd | | 01/01/2013 | 1-20 | No | VALIDATED |   |
| | 3 | | A mesoscopic model for coupled drape-infusion simulation of biaxial Non Crimp Fabric | Sirtautas J., Pickett AK., and Lépicier P. | Composites Part B: Engineering | 47 | Elsevier Limited | | 01/01/2013 | 48-57 | No | VALIDATED |   |
| | 4 | | Drapier Gas transport in fibrous media : application to in-plane permeability measurement using transient flow, Journal of Composite Materials | Y. Hou, S. Comas-Cardona, C. Binetruy, and S. Drapier | Journal of Composite Materials | 47,18 | SAGE Publications Ltd | | 18/08/2013 | 01-20 | No | VALIDATED |   |

LIST OF DISSEMINATION ACTIVITIES

| N° | Type of activities | Main leader | Title | Date | Place | Type of audience | Size of audience | Countries addressed | Status | Actions | Order |
|----|---|----------------------------------|--|------------|--------------------|--|------------------|---------------------|-----------|---|---|
| 1 | Oral presentation to a wider public | ESI GROUP S.A. | Simulation de procédé pour matériaux composites - Couplage Stokes / Darcy / solide en grandes déform | 23/05/2011 | Le Havre, France | Scientific community (higher education, Research) | 200 | France | VALIDATED |   |   |
| 2 | Oral presentation to a wider public | ESI GROUP S.A. | Simulation infusion process for composite materials - Coupling Stokes, Darcy and solid finite deform | 25/10/2011 | Arcachon, France | Scientific community (higher education, Research) | 200 | France, Europe | VALIDATED |   |     |
| 3 | Oral presentation to a scientific event | ESI GROUP S.A. | Curing and distortion analysis | 28/10/2011 | Stuttgart, Germany | Scientific community (higher education, Research) | 50 | Germany, Europe | VALIDATED |   |     |
| 4 | Oral presentation to a scientific event | ESI GmbH | Coupled manufacture and performance simulation for braids, tow placement and draping | 04/10/2010 | Bordeaux, France | Scientific community (higher education, Research) - Industry | 50 | France, Europe | VALIDATED |   |     |
| 5 | Oral presentation to a wider public | ISRAEL AEROSPACE INDUSTRIES LTD. | Simulation based optimization of industrial manufacture of large composite parts by infusion | 07/10/2010 | EADS Paris | Scientific community (higher education, Research) | 80 | Europe | VALIDATED |   |     |
| 6 | Oral presentation to a scientific event | UNIVERSITAET STUTTGART | Analysis and process simulation of textile structures | 26/01/2011 | ETH Zurich | Scientific community (higher education, Research) - Industry | 100 | Switzerland, Europe | VALIDATED |   |     |
| 7 | Oral presentation to a scientific event | SWEREA SICOMP AB | Process simulation of composite curing - Modeling of heat transfert, residual stresses and shape dis | 04/10/2010 | Bordeaux, France | Scientific community (higher education, Research) | 50 | France, Europe | VALIDATED |   |     |
| 8 | Oral presentation to a scientific event | KATHOLIEKE UNIVERSITEIT LEUVEN | In-situ measurements of fabric thickness evolution during draping and compressibility of sheared fab | 27/04/2011 | Belfast, UK | Scientific community (higher education, Research) | 300 | Europe | VALIDATED |   |     |
| 9 | Oral presentation to a scientific event | KATHOLIEKE UNIVERSITEIT LEUVEN | Modeling of textile composites | 04/10/2010 | Bordeaux, France | Scientific community (higher education, Research) - Industry | 50 | France, Europe | VALIDATED |   |     |

| | | | | | | | | | | | |
|----|---|--------------------------------|--|------------|--------------------------------|--|-----|----------------|-----------|---|---|
| 10 | Oral presentation to a scientific event | KATHOLIEKE UNIVERSITEIT LEUVEN | Limits of usefulness of kinematic drape models: Is it important to introduce true material mechanics | 01/05/2010 | Orleans | Scientific community (higher education, Research) | 200 | France, Europe | VALIDATED |   |    |
| 11 | Oral presentation to a scientific event | UNIVERSITY OF PATRAS | An extensive cost analysis study applied to the manufacturing of an aeronautic stiffened panel | 25/06/2013 | Kos, Greece | Scientific community (higher education, Research) | 200 | Greece, Europe | VALIDATED |   |    |
| 12 | Oral presentation to a scientific event | ESI GmbH | Macro- and mesoscopic modelling of textile composites | 01/09/2012 | Paris, France | Scientific community (higher education, Research) - Industry | 50 | France, Europe | VALIDATED |   |    |
| 13 | Oral presentation to a scientific event | UNIVERSITAET STUTT GART | Fabric permeability testing and their use in infusion simulation | 01/04/2013 | Aalborg, Denmark | Scientific community (higher education, Research) | 250 | Europe | VALIDATED |   |    |
| 14 | Oral presentation to a scientific event | ESI GmbH | 'Process and challenges for resin infusion simulation of large structural composite parts | 18/04/2012 | CCeV at DLR Stuttgart, Germany | Scientific community (higher education, Research) | 100 | Germany | VALIDATED |   |    |
| 15 | Oral presentation to a scientific event | UNIVERSITAET STUTT GART | 'Challenges of VARI process simulation: materials testing and simulation approaches | 25/07/2013 | CCeV at Augsburg, Germany | Scientific community (higher education, Research) | 100 | Germany | VALIDATED |   |    |
| 16 | Oral presentation to a scientific event | UNIVERSITAET STUTT GART | Resin infusion simulation for large structural composite parts | 19/09/2013 | Leuven, Belgium | Scientific community (higher education, Research) - Industry | 300 | Europe | VALIDATED |   |    |
| 17 | Oral presentation to a scientific event | CRANFIELD UNIVERSITY | Methodology applied to integrate a viscosity model for liquid composites molding in PAM-RTM | 02/06/2012 | Europe | Scientific community (higher education, Research) | 200 | Europe | VALIDATED |   |    |
| 18 | Oral presentation to a scientific event | CRANFIELD UNIVERSITY | Methodology applied to integrate a viscosity model for liquid composites molding in PAM-RTM | 21/05/2012 | Baltimore, USA | Scientific community (higher education, Research) | 200 | World | VALIDATED |   |    |

| | | | | | | | | | | |
|----|---|---|--|------------|--------------------------|--|------|-----------------|---|---|
| 19 | Oral presentation to a scientific event | CRANFIELD UNIVERSITY | Multi-objective optimisation of composites cure using genetic algorithms | 24/06/2012 | Venice, Italy | Scientific community (higher education, Research) | 200 | Europe | VALIDATED   |       |
| 20 | Oral presentation to a scientific event | CRANFIELD UNIVERSITY | Influence of residual stress on the delamination and shear response of carbon epoxy composites | 24/06/2012 | Venice, Italy | Scientific community (higher education, Research) | 1000 | Europe | VALIDATED   |       |
| 21 | Oral presentation to a scientific event | ESI GROUP S.A. | Multi-Objective infusion optimization in Vacuum Assisted Resin Transfer Moulding (VARTM) using genet | 28/07/2013 | Montreal, Canada | Scientific community (higher education, Research) | 1000 | World | VALIDATED   |       |
| 22 | Oral presentation to a scientific event | CRANFIELD UNIVERSITY | Composite cure modeling and optimization | 04/10/2010 | Bordeaux, France | Scientific community (higher education, Research) - Industry | 50 | France, Europe | VALIDATED   |       |
| 23 | Oral presentation to a scientific event | ESI GROUP S.A. | Resins modeling for advanced infusion | 28/09/2011 | Stuttgart, Germany | Scientific community (higher education, Research) | 50 | Germany, Europe | VALIDATED   |       |
| 24 | Oral presentation to a scientific event | ASSOCIATION POUR LA RECHERCHE ET LE DEVELOPPEMENT DES METHODES ET PROCESSUS INDUSTRIELS - ARMINES | Transient Air Permeability Measurement of Fibrous Reinforcement. In Proceedings of the 18th Internat | 21/08/2011 | Jeju Island, South Korea | Scientific community (higher education, Research) | 200 | World | VALIDATED   |       |
| 25 | Oral presentation to a scientific event | ASSOCIATION POUR LA RECHERCHE ET LE DEVELOPPEMENT DES METHODES ET PROCESSUS INDUSTRIELS - ARMINES | Accounting for material and process variability in order to improve by computer simulation composite | 28/10/2011 | Stuttgart, Germany | Scientific community (higher education, Research) - Industry | 50 | Germany, Europe | VALIDATED   |       |
| 26 | Oral presentation to a scientific event | ASSOCIATION POUR LA RECHERCHE ET LE DEVELOPPEMENT DES METHODES ET PROCESSUS INDUSTRIELS - ARMINES | Simulation infusion process for composite materials – Coupling Stokes, Darcy and solid finite deform | 25/10/2011 | Arcachon, France | Scientific community (higher education, Research) | 200 | France, Europe | VALIDATED   |       |
| 27 | Oral presentation to a scientific event | ASSOCIATION POUR LA RECHERCHE ET LE DEVELOPPEMENT DES METHODES ET PROCESSUS INDUSTRIELS - ARMINES | Simulation de procédé pour matériaux composites - Interaction Fluide/structure en grandes déformatio | 09/05/2011 | France | Scientific community (higher education, Research) | 100 | France | VALIDATED   |       |
| 28 | Oral presentation to a scientific event | ESI GROUP S.A. | Monolithic versus decoupled approach to couple stokes/darcy flows in extreme regimes for LCM process | 09/07/2012 | Auckland, New-Zealand | Scientific community (higher education, Research) - Industry | 400 | World | VALIDATED   |       |

| | | | | | | | | | | |
|----|---|---|--|------------|-----------------------|--|-----|-----------------|---|---|
| 29 | Oral presentation to a scientific event | ASSOCIATION POUR LA RECHERCHE ET LE DEVELOPPEMENT DES METHODES ET PROCESSUS INDUSTRIELS - ARMINES | Drapier Stokes-Darcy Coupling For Layers With High Permeability Ratio - Decoupled Approach | 10/09/2012 | Venice, Italy | Scientific community (higher education, Research) - Industry | 200 | Europe | VALIDATED   |     |
| 30 | Oral presentation to a scientific event | ESI GROUP S.A. | Industrial simulation of liquid resin infusion by the finite element method. In Proceedings of the 1 | 28/08/2013 | Montreal, Canada | Scientific community (higher education, Research) - Industry | 200 | World | VALIDATED   |     |
| 31 | Oral presentation to a scientific event | KATHOLIEKE UNIVERSITEIT LEUVEN | Local compressibility of draped woven fabrics | 24/06/2012 | Venice, Italy | Scientific community (higher education, Research) - Industry | 200 | Europe | VALIDATED   |     |
| 32 | Oral presentation to a scientific event | KATHOLIEKE UNIVERSITEIT LEUVEN | Efficient generation of the voxel description of textile geometries for the computation of the perme | 09/07/2012 | Auckland, New Zealand | Scientific community (higher education, Research) - Industry | 200 | World | VALIDATED   |     |
| 33 | Oral presentation to a scientific event | KATHOLIEKE UNIVERSITEIT LEUVEN | Compressibility of fibrous and nano reinforcements: experimental observations and modelling | 19/09/2013 | Leuven, Belgium | Scientific community (higher education, Research) - Industry | 250 | Belgium, Europe | VALIDATED   |     |

Section B (Confidential² or public: confidential information to be marked clearly)

Part B1

















| TEMPLATE B1: LIST OF APPLICATIONS FOR PATENTS, TRADEMARKS, REGISTERED DESIGNS, ETC. | | | | | |
|--|------------------------------------|--|--|---------------------------------|---------------------------------------|
| Type of IP Rights ³ : | Confidential Click on YES/NO | Foreseen embargo date dd/mm/yyyy | Application reference(s) (e.g. EP123456) | Subject or title of application | Applicant (s) (as on the application) |
| None | None | None | None | None | None |
| | | | | | |
| | | | | | |
| | | | | | |

















² Note to be confused with the "EU CONFIDENTIAL" classification for some security research projects.















³ A drop down list allows choosing the type of IP rights: Patents, Trademarks, Registered designs, Utility models, Others.

Part B2

Project Exploitable Foregrounds

| Type of exploitable foreground | Exploitable Foreground (description) | Confidential | Foreseen embargo date | Exploitable product(s) or measure(s) | Sector(s) of application | Timetable for commercial use or any other use | Patents or other IPR exploitation (licenses) | Owner & Other Beneficiary (s) involved | Status | Actions |
|--|---|--------------|-----------------------|--------------------------------------|---|---|--|--|-----------|---|
| Commercial exploitation of R&D results | New software developments (PAM-FORM) New developments including: • Fabric shear • Thickness • Bending | Yes | | PAM-FORM | Aeronautic, Automotive, Manufacturing | Immediate | ESI Group software | 1. ESI GmbH 5. ESI Group | VALIDATED |   |
| Commercial exploitation of R&D results | Enhanced software developments (PAM-RTM), Continuous progress has been made on PAM-RTM and a DMP version | Yes | | PAM-RTM | Aeronautic, Automotive, Manufacturing | Immediate | ESI Group software | 1. ESI GmbH 5. ESI Group | VALIDATED |   |
| Commercial exploitation of R&D results | Meso-scale modelling for draping: Collaboration with IFB has led to new meso-scale modelling methods having greatly improved accuracy for drape modelling | Yes | | PAM-FORM | Aeronautic, Automotive, Manufacturing | Immediate | ESI Group software | 1. ESI GmbH 5. ESI Group 13. IFB | VALIDATED |   |
| Commercial exploitation of R&D results | Database infusion process | Yes | | N/A | Aerospace | Immediate | N/A | Daher Aerospace | VALIDATED |   |
| Commercial exploitation of R&D results | Evaluation of simulation tool relevance | Yes | | N/A | Aerospace | Immediate | N/A | Daher Aerospace | VALIDATED |   |
| Commercial exploitation of R&D results | New software developments Task 5.5 (PAM-RTM) | Yes | | N/A | Aeronautic, Automotive, Manufacturing, Naval, Wind energy | >12 months | ESI Group software | ESI Group | VALIDATED |   |
| General advancement of knowledge | Method of in-plane and through permeability testing: Experimental methodology and protocol | Yes | | N/A | None, R&T purpose only | Confidentiality according to INFUCOMP agreement | None, R&T purposes only | 6. Hexcel 2. ARMINES | VALIDATED |   |
| General advancement of knowledge | Method of compression testing: Experimental methodology and protocol | Yes | | N/A | None, R&T purpose only | Confidentiality according to INFUCOMP agreement | None, R&T purpose only | 6. Hexcel 2. ARMINES | VALIDATED |   |

| | | | | | | | | |
|--|---|-----|---|--|------------------|--|---|---|
| Commercial exploitation of R&D results | Software implementing meso-models of fabric permeability – new version: Software FlowTex (part of WiseTex package) | Yes | WiseTex | Aeronautic, Automotive, Manufacturing, Wind energy | Immediate | Copyright on the software, distribution under license | KU Leuven | VALIDATED   |
| General advancement of knowledge | Methods of formability testing of preforms: Experimental methodology and protocol | Yes | N/A | Aeronautic, Automotive, Wind energy | Immediate | Reports copyrighted by KULEUVEN | KU Leuven | VALIDATED   |
| Commercial exploitation of R&D results | Cost Analysis modelling: Cost Analysis implementation on commercial software platform | Yes | Not yet defined | Composites manufacturing industry | To be considered | Not yet defined | 13. University of Patras 3. Cranfield University 1. ESI GmbH 5. ESI Group | VALIDATED   |
| Commercial exploitation of R&D results | Improved infusion production capability: Improved production engineering capability for infused parts | Yes | N/A | Aircraft structural components | 3-5 years | Company restricted documentation | 11. IAI 1. ESI GmbH | VALIDATED   |
| Commercial exploitation of R&D results | Bagging membrane modelling: Membrane model characterization parameters Further research possible to improve characterization (e.g. backing reinforcement) | Yes | N/A | Aerospace | Immediate | Infucomp reports / Confidential data of Bombardier Aerospace | 13. IFB 10. Bombardier Aerospace | VALIDATED   |
| General advancement of knowledge | Caul plate modelling: Knowledge on test and numerical modeling of Caul plates: Effect on fabric permeability. Purpose built rig constructed for testing via pressure plates. A topic for further research | Yes | FABRIC COMPACTION IMPACT ON PERMEABILITY | Aeronautic, Automotive, Manufacturing, Wind energy | Immediate | Confidential IFB reports | IFB | VALIDATED   |
| General advancement of knowledge | Preform modelling: New knowledge on racetrack test/modeling gained; further exploitation via research possible New meso- scale modeling work improves current | Yes | PREFORM MODELLING APPROACHES (DEFORMATION AND INFUSION) | Aeronautic, Automotive, Manufacturing, Wind energy | 6-12 months | Confidential IFB reports | IFB | VALIDATED   |
| General advancement of knowledge | Permeability testing: New rig for VARI processes built and suitable for industrial permeability measurements | Yes | FABRICS PERMEABILITY ESTIMATION METHODOLOGY | Aeronautic, Automotive, Manufacturing, Wind energy | Immediate | Confidential IFB reports | IFB | VALIDATED   |

| | | | | | | | | |
|----------------------------------|--|-----|-----|-------------------------------------|--------------|--------------------------------|--|---|
| General advancement of knowledge | Use of Resin Infusion Manufacturing Technique on large components: Design and Manufacturing Guidelines | Yes | N/A | Aeronautic, Automotive, Wind energy | Immediate | Reports copyrighted by Piaggio | Piaggio | VALIDATED   |
| General advancement of knowledge | Viscosity modelling: New viscosity modelling framework developed and implemented in PAM-RTM | Yes | N/A | Aerospace | Immediate | None | 3. Cranfield University 5. ESI Group | VALIDATED   |
| General advancement of knowledge | Viscosity characterisation: New cyclic viscosity characterisation experiment | Yes | N/A | Aerospace | Immediate | None | Cranfield University | VALIDATED   |
| General advancement of knowledge | Constitutive models for cure modelling: Set of models developed for two aerospace epoxies (RTM6, 890RTM) | Yes | N/A | Aerospace | Immediate | None | 3. Cranfield University 9. Swerea SICOMP | VALIDATED   |
| General advancement of knowledge | Multi-objective cure optimisation: Algorithm for cure profile optimisation | Yes | N/A | Aerospace | 12-36 months | None | 3. Cranfield University 10. Bombardier Aerospace | VALIDATED   |
| General advancement of knowledge | Multi-objective infusion optimisation: Algorithm for infusion thermal profile optimisation | Yes | N/A | Aerospace | 12-36 months | None | Cranfield University | VALIDATED   |
| General advancement of knowledge | Modelling-monitoring integration: Inverse scheme and algorithm for on-line estimation of fabric permeability | Yes | N/A | Aerospace | 12-36 months | None | Cranfield University | VALIDATED   |

4.1 Report on societal implications

| A General Information <i>(completed automatically when Grant Agreement number is entered.</i> | |
|---|---------------------|
| Grant Agreement Number: | ACP8-GA-2009-233926 |
| Title (acronym) of Project: | INFUCOMP |
| Name and Title of Coordinator: | Dr Anthony Pickett |
| B Ethics | |
| 1. Did your project undergo an Ethics Review (and/or Screening)? <ul style="list-style-type: none"> If Yes: have you described the progress of compliance with the relevant Ethics Review/Screening Requirements in the frame of the periodic/final project reports? <p>Special Reminder: the progress of compliance with the Ethics Review/Screening Requirements should be described in the Period/Final Project Reports under the Section 3.2.2 'Work Progress and Achievements'</p> | <i>No</i> |
| 2. Please indicate whether your project involved any of the following issues (tick box) : | YES |
| RESEARCH ON HUMANS | |
| • Did the project involve children? | |
| • Did the project involve patients? | |
| • Did the project involve persons not able to give consent? | |
| • Did the project involve adult healthy volunteers? | |
| • Did the project involve Human genetic material? | |
| • Did the project involve Human biological samples? | |
| • Did the project involve Human data collection? | |
| RESEARCH ON HUMAN EMBRYO/FOETUS | |
| • Did the project involve Human Embryos? | |
| • Did the project involve Human Foetal Tissue / Cells? | |
| • Did the project involve Human Embryonic Stem Cells (hESCs)? | |
| • Did the project on human Embryonic Stem Cells involve cells in culture? | |
| • Did the project on human Embryonic Stem Cells involve the derivation of cells from Embryos? | |
| PRIVACY | |
| • Did the project involve processing of genetic information or personal data (eg. health, sexual lifestyle, ethnicity, political opinion, religious or philosophical conviction)? | |
| • Did the project involve tracking the location or observation of people? | |
| RESEARCH ON ANIMALS | |
| • Did the project involve research on animals? | |
| • Were those animals transgenic small laboratory animals? | |
| • Were those animals transgenic farm animals? | |
| • Were those animals cloned farm animals? | |
| • Were those animals non-human primates? | |
| RESEARCH INVOLVING DEVELOPING COUNTRIES | |
| • Did the project involve the use of local resources (genetic, animal, plant etc)? | |
| • Was the project of benefit to local community (capacity building, access to healthcare, education etc)? | |
| DUAL USE | NO |

| | |
|--|----|
| <ul style="list-style-type: none"> • Research having direct military use • Research having the potential for terrorist abuse | No |
|--|----|

C Workforce Statistics

3. Workforce statistics for the project: Please indicate in the table below the number of people who worked on the project (on a headcount basis).

| Type of Position | Number of Women | Number of Men |
|--|-----------------|---------------|
| Scientific Coordinator | | 1 |
| Work package leaders | 1 | 7 |
| Experienced researchers (i.e. PhD holders) | | 6 |
| PhD Students | | 4 |
| Other | | |

4. How many additional researchers (in companies and universities) were recruited specifically for this project? **4**

Of which, indicate the number of men: **4**

D Gender Aspects

| | | |
|--|----------------------------------|-----|
| 5. Did you carry out specific Gender Equality Actions under the project? | <input type="radio"/> | Yes |
| | <input checked="" type="radio"/> | No |

6. Which of the following actions did you carry out and how effective were they?

| | Not at all effective | Very effective |
|---|-----------------------|-----------------------|
| <input type="checkbox"/> Design and implement an equal opportunity policy | <input type="radio"/> | <input type="radio"/> |
| <input type="checkbox"/> Set targets to achieve a gender balance in the workforce | <input type="radio"/> | <input type="radio"/> |
| <input type="checkbox"/> Organise conferences and workshops on gender | <input type="radio"/> | <input type="radio"/> |
| <input type="checkbox"/> Actions to improve work-life balance | <input type="radio"/> | <input type="radio"/> |
| <input type="radio"/> Other: <input type="text" value="None"/> | | |

7. Was there a gender dimension associated with the research content – i.e. wherever people were the focus of the research as, for example, consumers, users, patients or in trials, was the issue of gender considered and addressed?

Yes- please specify

No

E Synergies with Science Education

8. Did your project involve working with students and/or school pupils (e.g. open days, participation in science festivals and events, prizes/competitions or joint projects)?

Yes- please specify

No

9. Did the project generate any science education material (e.g. kits, websites, explanatory booklets, DVDs)?

Yes- please specify

No

F Interdisciplinarity

10. Which disciplines (see list below) are involved in your project?

Main discipline⁴:

Associated discipline⁴:

Associated discipline⁴:

G Engaging with Civil society and policy makers

| | | |
|--|----------------------------------|-----|
| 11a Did your project engage with societal actors beyond the research community? (if 'No', go to Question 14) | <input type="radio"/> | Yes |
| | <input checked="" type="radio"/> | No |

11b If yes, did you engage with citizens (citizens' panels / juries) or organised civil society (NGOs, patients' groups etc.)?

No

Yes- in determining what research should be performed

Yes - in implementing the research

Yes, in communicating /disseminating / using the results of the project

⁴ Insert number from list below (Frascati Manual).

| | | |
|--|---|---|
| 11c In doing so, did your project involve actors whose role is mainly to organise the dialogue with citizens and organised civil society (e.g. professional mediator; communication company, science museums)? | <input type="radio"/> <input type="radio"/> | Yes No |
| 12. Did you engage with government / public bodies or policy makers (including international organisations) | | |
| <input checked="" type="radio"/> No <input type="radio"/> Yes- in framing the research agenda <input type="radio"/> Yes - in implementing the research agenda <input type="radio"/> Yes, in communicating /disseminating / using the results of the project | | |
| 13a Will the project generate outputs (expertise or scientific advice) which could be used by policy makers? <input type="radio"/> Yes – as a primary objective (please indicate areas below- multiple answers possible) <input type="radio"/> Yes – as a secondary objective (please indicate areas below - multiple answer possible) <input checked="" type="radio"/> No | | |
| 13b If Yes, in which fields? | | |
| Agriculture Audiovisual and Media Budget Competition Consumers Culture Customs Development Economic and Monetary Affairs Education, Training, Youth Employment and Social Affairs | Energy Enlargement Enterprise Environment External Relations External Trade Fisheries and Maritime Affairs Food Safety Foreign and Security Policy Fraud Humanitarian aid | Human rights Information Society Institutional affairs Internal Market Justice, freedom and security Public Health Regional Policy Research and Innovation Space Taxation Transport |

| | | |
|---|--|--|
| 13c If Yes, at which level? <input type="radio"/> Local / regional levels <input type="radio"/> National level <input type="radio"/> European level <input type="radio"/> International level | | |
| H Use and dissemination | | |
| 14. How many Articles were published/accepted for publication in peer-reviewed journals? | | 4 |
| To how many of these is open access⁵ provided? | | 0 |
| How many of these are published in open access journals? | | 0 |
| How many of these are published in open repositories? | | 0 |
| To how many of these is open access not provided? | | 4 |
| Please check all applicable reasons for not providing open access: | | |
| <input checked="" type="checkbox"/> publisher's licensing agreement would not permit publishing in a repository <input type="checkbox"/> no suitable repository available <input type="checkbox"/> no suitable open access journal available <input type="checkbox"/> no funds available to publish in an open access journal <input type="checkbox"/> lack of time and resources <input type="checkbox"/> lack of information on open access <input type="checkbox"/> other ⁶ : | | |
| 15. How many new patent applications ('priority filings') have been made? <i>("Technologically unique": multiple applications for the same invention in different jurisdictions should be counted as just one application of grant).</i> | | 0 |
| 16. Indicate how many of the following Intellectual Property Rights were applied for (give number in each box). | Trademark | 0 |
| | Registered design | 0 |
| | Other | 0 |
| 17. How many spin-off companies were created / are planned as a direct result of the project? | | 0 |
| <i>Indicate the approximate number of additional jobs in these companies:</i> | | |
| 18. Please indicate whether your project has a potential impact on employment, in comparison with the situation before your project: | | |
| <input type="checkbox"/> Increase in employment, or <input checked="" type="checkbox"/> Safeguard employment, or <input type="checkbox"/> Decrease in employment, <input type="checkbox"/> Difficult to estimate / not possible to quantify | <input checked="" type="checkbox"/> <input checked="" type="checkbox"/> <input type="checkbox"/> | In small & medium-sized enterprises In large companies None of the above / not relevant to the project |
| 19. For your project partnership please estimate the employment effect resulting directly from your participation in Full Time Equivalent (FTE = one person working fulltime for a year) jobs: | | <i>Indicate figure:</i> x |
| Difficult to estimate / not possible to quantify | | |

I Media and Communication to the general public

20. As part of the project, were any of the beneficiaries professionals in communication or media relations?

Yes No

21. As part of the project, have any beneficiaries received professional media / communication training / advice to improve communication with the general public?

Yes No

22 Which of the following have been used to communicate information about your project to the general public, or have resulted from your project?

- | | |
|--|--|
| <input type="checkbox"/> Press Release | <input type="checkbox"/> Coverage in specialist press |
| <input type="checkbox"/> Media briefing | <input type="checkbox"/> Coverage in general (non-specialist) press |
| <input type="checkbox"/> TV coverage / report | <input type="checkbox"/> Coverage in national press |
| <input type="checkbox"/> Radio coverage / report | <input type="checkbox"/> Coverage in international press |
| <input type="checkbox"/> Brochures /posters / flyers | <input checked="" type="checkbox"/> Website for the general public / internet |
| <input type="checkbox"/> DVD /Film /Multimedia | <input type="checkbox"/> Event targeting general public (festival, conference, exhibition, science café) |

23 In which languages are the information products for the general public produced?

- | | |
|--|---|
| <input type="checkbox"/> Language of the coordinator | <input checked="" type="checkbox"/> English |
| <input type="checkbox"/> Other language(s) | |

Question F-10: Classification of Scientific Disciplines according to the Frascati Manual 2002 (Proposed Standard Practice for Surveys on Research and Experimental Development, OECD 2002):

FIELDS OF SCIENCE AND TECHNOLOGY

1. NATURAL SCIENCES

- 1.1 Mathematics and computer sciences [mathematics and other allied fields: computer sciences and other allied subjects (software development only; hardware development should be classified in the engineering fields)]
- 1.2 Physical sciences (astronomy and space sciences, physics and other allied subjects)
- 1.3 Chemical sciences (chemistry, other allied subjects)
- 1.4 Earth and related environmental sciences (geology, geophysics, mineralogy, physical geography and other geosciences, meteorology and other atmospheric sciences including climatic research, oceanography, vulcanology, palaeoecology, other allied sciences)
- 1.5 Biological sciences (biology, botany, bacteriology, microbiology, zoology, entomology, genetics, biochemistry, biophysics, other allied sciences, excluding clinical and veterinary sciences)

2. ENGINEERING AND TECHNOLOGY

- 2.1 Civil engineering (architecture engineering, building science and engineering, construction engineering, municipal and structural engineering and other allied subjects)
- 2.2 Electrical engineering, electronics [electrical engineering, electronics, communication engineering and systems, computer engineering (hardware only) and other allied subjects]
- 2.3 Other engineering sciences (such as chemical, aeronautical and space, mechanical, metallurgical and materials engineering, and their specialised subdivisions; forest products; applied sciences such as geodesy, industrial chemistry, etc.; the science and technology of food production; specialised

⁵ Open Access is defined as free of charge access for anyone via Internet.

⁶ For instance: classification for security project.

technologies of interdisciplinary fields, e.g. systems analysis, metallurgy, mining, textile technology and other applied subjects)

3. MEDICAL SCIENCES

- 3.1 Basic medicine (anatomy, cytology, physiology, genetics, pharmacy, pharmacology, toxicology, immunology and immuno-haematology, clinical chemistry, clinical microbiology, pathology)
- 3.2 Clinical medicine (anaesthesiology, paediatrics, obstetrics and gynaecology, internal medicine, surgery, dentistry, neurology, psychiatry, radiology, therapeutics, otorhinolaryngology, ophthalmology)
- 3.3 Health sciences (public health services, social medicine, hygiene, nursing, epidemiology)

4. AGRICULTURAL SCIENCES

- 4.1 Agriculture, forestry, fisheries and allied sciences (agronomy, animal husbandry, fisheries, forestry, horticulture, other allied subjects)
- 4.2 Veterinary medicine

5. SOCIAL SCIENCES

- 5.1 Psychology
- 5.2 Economics
- 5.3 Educational sciences (education and training and other allied subjects)
- 5.4 Other social sciences [anthropology (social and cultural) and ethnology, demography, geography (human, economic and social), town and country planning, management, law, linguistics, political sciences, sociology, organisation and methods, miscellaneous social sciences and interdisciplinary, methodological and historical S1T activities relating to subjects in this group. Physical anthropology, physical geography and psychophysiology should normally be classified with the natural sciences].

6. HUMANITIES

- 6.1 History (history, prehistory and history, together with auxiliary historical disciplines such as archaeology, numismatics, palaeography, genealogy, etc.)
- 6.2 Languages and literature (ancient and modern)
- 6.3 Other humanities [philosophy (including the history of science and technology) arts, history of art, art criticism, painting, sculpture, musicology, dramatic art excluding artistic "research" of any kind, religion, theology, other fields and subjects pertaining to the humanities, methodological, historical and other S1T activities relating to the subjects in this group]

2. FINAL REPORT ON THE DISTRIBUTION OF THE EUROPEAN UNION FINANCIAL CONTRIBUTION

This report shall be submitted to the Commission within 30 days after receipt of the final payment of the European Union financial contribution.

Report on the distribution of the European Union financial contribution between beneficiaries