



The IDEALIST Flexgrid/Flexrate/Flexreach Technology Solution

Status and Version:	Version 20	
Date of issue:	13.11.2015	
Distribution:	Public	
Author(s):	Name	Partner
	Emilio Hugues-Salas	UNIVBRIS
	Shuangi Yan	UNIVBRIS
	Yan Yan	UNIVBRIS
	Geogios Zervas	UNIVBRIS
	Dimitra Simeonidou	UNIVBRIS
	Patricia Layec	ALBLF
	Arnaud Dupas	ALBLF
	Andrew Lord	BT
	Nicola Sambo	CNIT
	Filippo Cugini	CNIT
	Antonio Napoli	Coriant
	Marc Bohn	Coriant
	Francesco Giurlanda	Coritel
	Josep M. Fabrega	CTTC
	Michela Svaluto Moreolo	CTTC
	Laura Martín González	CTTC
	Matthias Gunkel	DT
	Antonio D'Errico	Ericsson
	Markus Noelle	HHI
	Anna Chiadò Piat	TI
	Emilio Riccardi	TI
	Chigo Okonkwo	TU/e
	Huug de Waardt	TU/e
	Talha Rahman	TU/e
	Alexandros Stavdas	UoP
	Chris Matrakidis	UoP



Checked by:	Emilio Riccardi	TI
	Nicola Sambo	CNIT
	Andrew Lord	BT



Executive Summary

This is the final WP2 deliverable in the project and its intention is to summarize the IDEALIST vision and activities regarding data plane technological solutions to enable Elastic Optical Networks (EONs) and to support their gradual evolution. The purpose of this document is different from that of “Lessons and conclusions from elastic optical networks” [IDEALIST-D1.6], which aims at setting the entire project into context addressing questions such as “why”, “how” and “when” the Elastic Optical Networks should become reality. The target of this deliverable is to focus only on the “how” and “when”, providing more of an “equipment-vendor-oriented” perspective, which should be seen as complementary and an extension of the aforementioned document D1.6.

In the shorter term horizon, the effectiveness and maturity of data plane technologies and relevant standardization activities is the main aspect to consider, as these technologies are the actual ground on which EON will be built. Moreover the full EON capabilities are not expected to be immediately employed by network operators within this horizon.

In the mid-term, enhanced technological solutions are certainly needed to both increase the capacity, flexibility and transmission performance of installed first generation EON systems without compromising cost, footprint and power consumption.

Accordingly, we believe that the next five to six year time frame can be reasonably subdivided into two time ranges, indicatively from now up to 2017/18 and then up to 2021, in which the availability and maturity of specific concrete technological solutions will enable a ready and effective introduction of the EON transport systems in European operator’s networks.

IDEALIST proposal for the two temporal ranges are respectively identified as **short-term solutions** and **mid-term advanced solutions**.

Within these time frames the most relevant innovation is expected to be the rise and evolution of the (sliceable) bandwidth variable transponder (S-BVT) characterized by three main novelties with respect to current fixed ones: (I) the efficient use of the optical spectrum through the new ITU-T standard allowing for 12.5 GHz resolution; (II) the generation of different modulation formats; and (III) the possibility of switching between different codes (e.g., FEC). On the top of that, we can consider, in a mid-term perspective, different transmission schemes such as: Nyquist WDM (NWDM), Time-Frequency-Packing (TFP), and Orthogonal Frequency Division Multiplexing (OFDM) to optimize spectral efficiency. Sliceability adds another degree of freedom to S-BVT allowing for sub-carriers generated by the same S-BVT to be independently modulated and routed in the network. All these ingredients greatly increase the amount of elasticity within next generation EON as discussed in Section 4.3.

To support this flexibility at the line interfaces, a similar flexibility should be desirable also in the digital optical transport network (OTN) layer. Actual OTN standardization activities consider this flexibility mainly at the ODU layer, accepting a coarse 100G granularity at the OTU layer. A finer granularity is advisable especially in the interconnection between metro and backbone areas (Section 5.1), and is currently under discussion to provide more flexibility at the OTU level for beyond 100G (OTUflex), but at present it seems unlikely that “first generation” EONs will benefit from this opportunity. In the mid-term, this option will fully leverage the flexible transmission parameters of the physical layer in order to optimize simultaneously the data rate, the reach and spectrum occupancy.



The control of S-BVT transmission functionalities such as the number of active optical flows, the bit rate, and the distance adaptation, is another important issue extensively discussed between WP2 and WP3, as well as monitoring such as the one enabled by the DSP itself. In a mid and longer term perspective, code adaptation can be also exploited to hitlessly react to physical layer degradations (Section 4.4).

Some network operators are firmly convinced that EON will greatly benefit from a standardized “black link” environment for the cost reduction that an open component “ecosystem” should bring. IDEALIST has extensively discussed the feasibility of these interoperability scenarios, defining a list of parameters to be standardized; it has also experimentally demonstrated the feasibility of interoperability at the DSP level (Section 4.5). We believe that the greatest benefits from a “black link” approach will be in networks with a real optical multivendor environment, although agreement among different vendors is expected to be hard to achieve. For this reason, the interoperability scenario might be realized only in a medium/long term perspective.

Turning now the focus to the optical switching node, in the short and medium term time frame the ROADM architecture is not expected to deviate from the traditional broadcast-and-select or switch-and-select, with Colorless / Directionless / Contentionless (CDC) modular Add&Drop functionalities. Footprint, power and cost reduction will push towards more integrated solutions (several BV-WSSs and amplifiers on the same card), mainly in the Add&Drop functionalities, and targeting the metro network segment. Moreover in the mid-term, a possible matching between CDC Add&Drop functionality of ROADM nodes and S-BVTs’ optical capacity is to be envisioned, looking for a trade-off between costs and performance (Section 4.2). Concerning the BV-WSS component itself, it is unlikely that devices with much higher performance in terms of steepest filtering capability will be soon available without compromising footprint and cost.

An aspect not to be overlooked and intimately related to the overall performance of a transmission system is how to design the links of a network and how to set the optical per-channel amplifier output power. This task may in principle be extremely demanding and time consuming in a flexible optical environment such as an EON. Surprisingly enough within the so-called Gaussian noise model framework, a set of technology unaware rules, providing models for a rapid and accurate transmission link design can be found. This modelling approach is valid for uncompensated optical networks, although each technological option will likely be more specific and tailored to the particular scenario under test. Within IDEALIST a tool has been developed with the purpose of supporting network operators in quickly evaluating network solutions from different vendors, for example during a tender (Section 4.6). This, or similar tools, possibly including filtering impairments and suitable system margin, may be applied also to support network planning or as part of optical network control plane. Ideally this system design tool should be completely technology independent and valid for all the proposed transmission techniques considered within IDEALIST (NWDM, TFP and OFDM). However, while this method seems to work very reliably for NWDM systems, further work is still necessary to accurately predict the performance of TFP and OFDM systems.

Short-term solutions

Different suppliers have already introduced in the market, components and subsystems as building blocks for EON transmission equipment, and system vendors have in their portfolio flexgrid ready ROADMs and Bandwidth Variable Transponders (BVTs) (Section 2.1). However EON is still in an early stage as some of the relevant technologies are in development.



Standardization activities carried out mainly in ITU-T, IEEE and OIF, are proceeding rapidly towards 400GbE (the expected main client of EONs), “beyond 100G OTN” and “black link” interworking standardizations (Section 2.2). Even if all of them are not yet finalized, the situation will consolidate fairly quickly, culminating with the expected approval by 2017 of the standard for 400GbE by the IEEE802.3 task force.

On the other hand, network operators are attracted by the opportunity of a quick introduction of EONs for the benefit offered by the flexible use of the optical spectrum and the potential OpEx saving due to the reduction in the number of items and stocks with the introduction of (S)-BVTs and related SDN functionalities.

Accordingly, we believe that near future backbone networks and the most demanding metro-area cases will be based on EONs, with flexgrid ROADM and BVTs. These networks are supposed to be almost transparent with few regenerators and employing mainly coherent technologies over uncompensated fibers (Sections 3 and 4).

The ROADM architecture will not fundamentally deviate from the traditional broadcast and select or switch and select ones, with CDC modular Add&Drop functionalities. BV-WSS with LCoS technology is already enabling flexgrid, offering full backwards compatibility with both the standard 100GHz and 50GHz ITU grids, also allowing a smooth upgrade of installed systems.

The EON data plane will see the introduction of line interfaces with software configurable total capacity ranging from 100Gbit/s to 400Gbit/s in 100Gbit/s steps, with possibly sliceable solutions (see Table 2 of Section 4.3.1). In most commercial solutions symbol rates are expected to be almost fixed, and flexibility will rely on the modulation format, FEC and the number of sub-carriers composing the super-channel.

The Nyquist WDM transmission technique will for sure dominate the market. Actually in IDEALIST, NWDM has been extensively analyzed, moving from simulation-based investigations to complete real-time BVTs used in some field trial experiments. Overall, NWDM represents a realistic solution that can be already purchased and we envision that it will play a fundamental role in the deployment of the first EONs.

A client agnostic transmission technology is advisable to handle Ethernet traffic together with the legacy and Other Licensed Operator (OLO) client traffic: digital wrapping and packet/OTN switching fabrics are probably the best technological choice.

The interoperability between different network segments will almost certainly be at OTN electrical level, as we conjecture that the standardization will not be complete for a black link interoperability model. In addition, within a single network operator domain, agreements between different suppliers will, sometime, enable the implementation of the “alien lambda” solution using flexible colored optical line interfaces (i.e. BVTs) equipped directly on router’s boards.

Concerning the control plane and monitoring, in both short/medium term time frames they are likely to be based on the standard IETF solution supported by IDEALIST. Relevant data plane parameters (e.g., capabilities supported by a transponder, such as modulation format) have to be exchanged to enable controllers for aware computations (e.g., impairment-aware Path Computation Element). Monitoring can make use of the DSP already in coherent receivers (e.g., Q-factor monitoring).

Mid-term solutions

After the consolidation of “first generation” EON products (2017/18), non-disruptive changes are expected as technology progresses smoothly (higher rates, enhanced



flexibility) as well as increased traffic. Sustainable capacity upgrade will be made possible by technological enhancement in footprint and power consumption – more capacity will be available on the same shelf- enabling the massive introduction of cost and power effective 1Tbit/s and sliceable BVT solutions (Section 4.7).

New and more efficient ASICs with enhanced DSP functionalities together with new digital OTN functionalities will give the opportunity of improving both flexibility (for example 25G instead of 100G steps in transmission capacity enabling OTUflex; hybrid modulation formats, etc.), and performance (non-linear impairment mitigation, next generation FEC, etc.), together with routes to (S)-BVTs with 1Tbit/s or more net capacity.

Concerning flexibility, IDEALIST is proposing code adaptation (Section 4.4 and 6.4) as a medium/long term solution for increasing the (S)-BVT overall flexibility. The main idea behind this is to properly encode the data so that certain targets (capacity, reach, etc.) are guaranteed. Additionally, code adaptation enables a fast and hitless adjustment to cope with dynamically evolving penalties without changing the modulation format.

Moreover, IDEALIST extensively analyzed, both theoretically and experimentally, several promising technological options enabling ≥ 1 Tbit/s net transmission capacity in next generation transponders. Among them two main paths can be foreseen (Section 4.4):

(I) Evolution towards higher order QAM formats and novel four dimensional constellations.

In order to increase the spectral efficiency and at the same time the overall capacity, in IDEALIST different solutions with several higher order modulation formats (i.e., 8/16/32/64/128QAM) at variable symbol rates were investigated. Moreover, advanced schemes such as 4D and hybrid modulation formats have been considered. All these schemes present quite different properties, with characteristics that will be utilized by the control plane to provide in every occasion the optimal solution in terms of reach, spectral efficiency and capacity.

(II) Multiple Carriers based on NWDM, TFP and OFDM.

NWDM is currently commercially available. It represents an evolution of well-established dense WDM systems by exploiting the aforementioned features of the flexible grid and transmitter tunability. With NWDM, significant increase in spectral efficiency has already been demonstrated. In this context, we investigated transmission over different fiber types, with different amplification schemes utilizing several modulation formats, which employed different code rates.

Another scheme considered for long-haul transmission is Time-Frequency-Packing (TFP). Using this technique we investigated the performance of super-channels up to 1Tbit/s line rate under several conditions and in particular in long optical paths traversing several hops of the network. Also for TFP, the BVT performance can be optimized by employing different coding.

The main idea of TFP is to employ low-order modulation formats such as QPSK, where the sub-carriers are closely packed together and to employ a more complex (compared to NWDM) receiver for compensating the introduced interference. In the current realization, TFP has the advantage with respect to NWDM of achieving the same Spectral efficiency of a DP-16QAM with NWDM, but by transmitting a DP-QPSK signal and without needing a DAC and components with large electrical bandwidth at the transmitter.

As part of the project, the partners working on these two topics (NWDM and TFP) agreed to carry out a joint experiment to compare the two transmission techniques when being transmitted over the same test-bed.



The last transmission scheme is OFDM. This method has been, within IDEALIST, mainly investigated for metropolitan area network (MAN) scenarios (Section 4.3 and 5.3). For example cost-effective flexgrid technologies based on OFDM have been assessed for a MAN scenario with centralized broadband remote access servers (BRASes), each serving several multi-tenant units (MTUs). The combination of the proposed transmission architectures for up/downstream communication constitutes a promising solution for serving the multiple endpoints using BVTs adopting OFDM at the BRASes. Experimental and simulation results show successful 10Gbit/s net BRAS-MTUs connections when serving different paths and coping with typical regional network distances. As with the other BVTs, it is also possible within OFDM to exploit the information for monitoring and improving system performance in a real time environment. For example, it is possible to adapt the modulation schemes, constituting the OFDM channel, by knowing the information on the current traverse filters in order to overcome the narrow filtering effect.

Finally addressing the issue of interoperability in a mid/long-term perspective, IDEALIST identified the main transmission parameters that are needed for example by the control plane. Based on this knowledge, an experiment was carried out on a Pan-European network demonstrating, for the first time, a multi-vendor and multi-domain EON with S-BVT and control interoperability. Two independent experiments also showed the clear need for the standardization of soft-decision FEC in order to guarantee interoperability up to regional distances (Section 4.5).

Long-term vision

Many other promising, though more evolutionary studies, undertaken within IDEALIST, will probably find a concrete application later in time, introducing more disruptive paradigms concerning, for example, node architectures. Collectively they are referred to as the IDEALIST *long term vision*.

The idea that informs the whole long-term IDEALIST vision is the distinction, though affected by a certain degree of arbitrariness, that there are problems manageable with solutions that evolve seamlessly from the ones adopted in the short/mid-term, and others which require a fairly disruptive change of paradigm.

Actually in a long-term perspective, the ROADM conventional node architectures are bound to show their limitation regarding the ability to adequately scale with the increase of traffic and the number of DWDM lines connecting each node. IDEALIST proposed an interesting candidate to overcome these limitations in the flexible Architecture on Demand (AoD) paradigm (Section 6.2). Extremely high capacity EONs will expect benefits by the introduction of AoD nodes due to the dynamic adaptation of the architecture according to the switching and processing requirements of the network traffic.

Moreover, in a high capacity EON, especially in national backbones or pan-European networks, regeneration of super-channel flows, if their intrinsic flexibility has to be completely exploited, will put additional stress on the optical node architecture and electronic structure of regeneration modules. IDEALIST identified in the modular SERANO architecture a possible long term solution to this challenging problem (Section 6.3).

This type of regeneration module efficiently support AoD nodes in both regeneration and other advanced optical engineering functions such as optical spectrum defragmentation for which a specific efficient implementation is discussed (Section 6.4). The defragmentation technique is named “push-pull”, and allows an optical signal to be shifted hitlessly in frequency thanks to the suitable use of an automatic frequency control typically implemented in coherent receivers.



Finally a particular figure of merit has been studied within IDEALIST: Flexibility. This figure of merit is of significant value since it directly corresponds to the definition of elasticity within EONs. The introduction of such a parameter, capable of weighting the various aspects of flexibility in a unitary manner, is expected to be an algorithmic tool of considerable interest in the medium and especially the long-term. In fact, it could be part of an automated system that assists the system designer and the network operator in the appropriate selection of technologies that best match the requirements of their networks. This perspective is promising although its full implementation is still to come.



Table of Contents

1	Introduction	11
1.1	Purpose and scope	11
1.2	References	12
1.3	Acronyms	20
1.4	Document history	24
1.5	Document overview	26
2	Data plane technology state of the art	29
2.1	Commercially available technologies	29
2.2	Standardization activities	31
3	IDEALIST Vision for Data Plane Technologies	34
4	Data plane solution for short and mid term	36
4.1	Node capacity, reach and flexibility	36
4.2	Optical ROADM architecture	37
4.3	Flexible transponders: (S)-BVT	39
4.3.1	(S)-BVT: 2017/18 perspective	39
4.3.2	Advanced solutions: 2021 and beyond perspectives	41
4.3.2.1	S-BVT based on Nyquist WDM	42
4.3.2.2	S-BVT based on Time Frequency Packing (TFP)	43
4.3.2.3	S-BVT based on Orthogonal Frequency Division Multiplexing (OFDM)	44
4.4	Control and Monitoring	44
4.4.1	Control	44
4.4.1.1	Main transmission parameters for control	44
4.4.1.2	Control of a S-BVT	46
4.4.1.3	Optical switching control	46
4.4.2	Monitoring	49
4.5	Elastic Black Link and Multivendor Interoperability	50
4.6	Tools for Optical Network Design	51
4.7	Sustainable technological path for (S)-BVT realization	54
5	Solutions for Metro Area Network and Interconnection with Backbone	58
5.1	Elastic interface for Metro/Core Border Node	58
5.2	Elastic Cross-connects (EXCs) and BV-WSSs	59
5.3	Solution for traffic aggregation in the metro/regional network domain	60
6	Long term perspective methodologies, and solutions	62
6.1	A Figure of Merit for flexibility assessment	62
6.2	Architecture on Demand	65



6.3	Regeneration and defragmentation options	68
6.3.1	SERANO solution	68
6.3.2	Developed algorithms for SERANO design	69
6.3.2.1	RMSA algorithms exploiting SERANO capabilities	69
6.3.2.2	Path Split algorithms	70
6.3.2.3	BVT Placement algorithms	71
6.3.2.4	RMSA algorithm performance evaluation	71
6.3.2.5	Physical layer performance of SERANO nodes	73
6.3.3	Defragmentation	76
6.4	Long term solutions for the Internal Control and Monitoring	77
7	Conclusions	78
8	Appendix	79
8.1	Sub-carrier generation module power consumption evaluation in BVT design	79
8.2	Data plane alternatives based on sliceable transceivers for optical aggregation networks	80
8.3	Results on flexibility measurements	82
8.4	Discrete Event Simulator for EON demonstrating the impact of SERANO	85



1 Introduction

1.1 Purpose and scope

This is the fourth deliverable from Work Package 2 of the IDEALIST project and the last of the project dealing with the data plane technological solutions associated to the introduction of Elastic Optical Networks (EONs) in next generation networks. The motivation and an overview of this deliverable have been provided in the Executive summary.

The core of the document is organized into four macro units.

Sections 2 and 3 provide first a brief survey of the state of the art of the EON related market. Then a comprehensive description of the IDEALIST vision for data plane evolution is given for both the short and medium term relevant solutions and the innovative ideas for a more far-off future.

Section 4 is dedicated to the description of the identified short and medium term IDEALIST solutions suitable for next generation regional, national and pan European optical backbone networks. Starting from the data plane technology state of the art (section 2), and considering its conceivable evolution within a short and mid-term time frame (corresponding approximately to next 3 to 6 years) several options are identified and described.

Section 5 describes solutions dedicated to the metro area network and its interconnection with the backbone. Although it is expected that the same solutions developed for other network segments can be applied efficiently also in metro area, the lower granularity of the traffic and the greater need for grooming allow for other interesting and innovative technological alternatives.

Section 6 gives the IDEALIST vision with a longer term perspective in mind, including the most innovative ideas developed to efficiently cope with very big and dynamic future traffic loads.

Section 7 concludes the deliverable while Section 8 reports in an Appendix new results not presented in previous deliverables.

1.2 References

- [Acacia PR-2015] <http://acacia-inc.com/acacia-communications-announces-the-industrys-first-coherent-flex-rate-400g-5x7-transceiver-module/>
- [ALU 400G PSE] <https://www.alcatel-lucent.com/innovation/400g-pse>
- [ALU PR-2015] <http://www.lightwaveonline.com/articles/innovation-awards/alcatel-lucent-1830-pss-rate-adaptive-100g-200g-solution.html>
- [Amaya-ECOC11] N. Amaya, G. Zervas, B. Rofoee, M. Irfan, Y. Qin, and D. Simeonidou, "Field trial of a 1.5 Tb/s adaptive and gridless OXC supporting elastic 1000-fold bandwidth granularity", European Conference. And Exposition on Optical Communications (ECOC), 2011, We.9.K.2.
- [Amaya-ECOC12] N. Amaya, M. Irfan, G. Zervas, R. Nejabati, D. Simeonidou, J. Sakaguchi, W. Klaus, B. J. Puttnam, T. Miyazawa, Y. Awaji, N. Wada, and I. Henning, "First fully-elastic multi-granular network with space/frequency/time switching using multi-core fibres and programmable optical nodes", European Conference. And Exposition on Optical Communications (ECOC), 2012, PDP, Th.3D3.
- [Amaya-ICTON11] N. Amaya, G. Zervas, and D. Simeonidou, "Architecture on demand for transparent optical networks", International Conference on Transparent Optical Networks (ICTON), 2011, pp. 1–4.
- [Amaya-JOCN13] N. Amaya, G. Zervas and D. Simeonidou, "Introducing Node Architecture Flexibility for Elastic Optical Networks", Journal of Optical Communications and Networking, Vol. 5, No. 6, pp. 593-608, June 2013.
- [Apache] Apache Commons Mathematics Library, Website : <http://commons.apache.org/proper/commons-math/>
- [Arakawa-ComMag13] Y. Arakawa, et al., "Silicon photonics for next generation system integration platform", Communications Magazine, IEEE, Vol. 51, no. 3, p. 72, 2013.
- [Assefa-IEDM12] S. Assefa, et al., "A 90nm CMOS integrated Nano-Photonics technology for 25Gbps WDM optical communications applications", IEEE International Electron Devices Meeting (IEDM), 2012, PDP session 33.8.
- [Autenrieth-ICTON11] A. Autenrieth, A. K. Tilwankar, C. M. Machuca, and J.-P. Elbers, "Power consumption analysis of opaque and transparent optical core networks", International Conference on Transparent Optical Networks (ICTON), 2011, pp. 1–5.
- [Bahl-TRANSINFO74] L. Bahl, J. Cocke, F. Jelinek, and J. Raviv, "Optimal decoding of linear codes for minimizing symbol error rate", IEEE Transactions on Information Theory, vol. IT-20, no. 2, pp. 284–287, Mar. 1974.
- [Buckwalter-CICC11] J. F. Buckwalter, Joohwa Kim, Xuezhe Zeng, Gouliang Li, Raj K., Krishnamoorthy, A., "A fully-integrated optical duobinary transceiver in a 130nm SOI CMOS technology", IEEE Custom Integrate Circuits Conference (CICC), 2011, p. 476.
- [Carena-OptE14] A. Carena, G. Bosco, V. Curri, Y. Jiang, P. Poggiolini, F. Forghieri, "EGN model of non-linear fiber propagation", OSA, Optics Express, Vol. 22, No. 13, pp. 16335-16362, 2014.
- Casellas-JSAC13 R. Casellas, R. Muñoz, J. M. Fabrega, M. Svaluto Moreolo, R. Martínez, L. Liu, T. Tsuritani, I. Morita, "Design and Experimental Validation of a GMPLS/PCE Control Plane for Elastic CO-OFDM Optical Networks", IEEE Journal on Selected Areas in Communications, Vol. 31, No. 1, January 2013.



- [Cisco] <http://www.cisco.com/c/en/us/products/collateral/optical-networking/network-convergence-system-2000-series/datasheet-c78-733699.html>
- [Clariphy] <http://www.clariphy.com/>
- [Coriant] http://www.coriant.com/products/documents/DS_hiT_7300_Flexirate_Interface_Modules_74C0119.pdf
- [Coriant-PR_TSCI-2015] http://www.coriant.com/company/press_release.asp?id=1232
- [Cugini-JOCN15] F. Cugini, F. Fresi, F. Paolucci, G. Meloni, N. Sambo, A. Giorgetti, T. Foggi, L. Potí, P. Castoldi, "Active stateful PCE with hitless LDPC code adaptation [Invited]", IEEE Journal of Optical Communications and Networking, vol.7, no.2, pp. A268-A276, February 1 2015.
- [Dallaglio-ECOC15] M. Dallaglio, N. Sambo, A. Pagano, E. Riccardi, A. Giorgetti, P. Castoldi, "On the Add & Drop architecture for S-BVTs in EONs", European Conference on Optical Communication (ECOC) 2015, OPN01.4.
- [Dar-JLT15] R. Dar, M. Feder, A. Mecozzi, M. Shtaif, "Pulse collision picture of inter-channel nonlinear interference in fiber-optic communications", IEEE Journal of Lightwave Technology, Vol. PP, No. 99, April 2015.
- [D'Errico-OFC16] A. D'Errico, "Next generation transponders for Terabit Optical Networks [Invited]", Invited paper at Optical Fiber Communication Conference and Exposition (OFC), Anaheim, Los Angeles, California, 2016.
- [DiCon] <http://www.diconfiberoptics.com/products/scd0253/scd0253a.pdf>
- [Dupas-OFC15] A. Dupas, E. Dutisseuil, P. Layec, P. Jenneve, S. Frigerio, Y. Yan, E. Hugues-Salas, G. Zervas, D. Simeonidou, S. Bigo, "Real-Time Demonstration of Software-Defined Elastic Interface for Flexgrid Networks", Optical Fiber Communication Conference and Exposition (OFC), 2015, M3A.2.
- [Dzanko-ECOC13] M. Dzanko, M. Furdek, N. Gonzalez, G. Zervas, B. Mikac, and D. Simeonidou, "Self-healing optical networks with architecture on demand nodes", European Conference and Exhibition on Optical Communication (ECOC), 2013, pp.1–3.
- [Dzanko-ICTON12] M. Dzanko, B. Mikac, N. Gonzalez, G. Zervas, D. Simeonidou, "Availability analysis of optical cross-connect implemented by architecture on demand" International Conference on Transparent Optical Networks (ICTON), 2012, Tu.C2.5.
- [Ericsson] http://www.ericsson.com/res/thecompany/docs/publications/ericsson_review/2014/er-ip-optical-convergence.pdf
- [Fabrega-ICTON13] J. M. Fabrega, P. Sevillano, M. Svaluto Moreolo, J. J. Martínez, A. Villafranca, J. M. Subías, "All-Optical In-Band OSNR Measurement in Intensity-Modulated Direct-Detection Optical OFDM Systems", International Conference on Transparent Optical Networks (ICTON), 2013.
- [Fabrega-ICTON15] J.M. Fabrega, L. Martín, M. Svaluto Moreolo, "Data plane alternatives based on sliceable transceivers for optical aggregation networks", International Conference on Transparent Optical Networks (ICTON), 2015, We.A1.4.
- [Fabrega-OFC15] J. M. Fabrega, M. Svaluto Moreolo, F. J. Vilchez, K. Christodoulopoulos, E. Varvarigos, J. Fernandez-Palacios, "Experimental validation of MTU-BRAS connectivity with DMT transmission and coherent detection in flexgrid metro networks using sliceable transceivers", Optical Fiber Communication Conference and Exposition (OFC), 2015.



- [Fabrega-OptCom15] J. M. Fabrega, P. Sevillano, M. Svaluto Moreolo, A. Villafranca, F. J. Vilchez, J. M. Subías, "OFDM subcarrier monitoring using high resolution optical spectrum analysis", IEEE Optics Communications, Vol. 342, pp. 144-151, May 2015.
- [Finisar-1] <https://www.finisar.com/roadms-wavelength-management/10wsaaxxfl>
- [Finisar-2] <https://www.finisar.com/optical-transceivers/ftlc3321x3nl>
- [Finisar-3] <https://www.finisar.com/optical-transceivers/ftlc3321x3nl>
- [Fujitsu PR-2015] <http://www.fujitsu.com/jp/group/foc/en/resources/news/press-releases/2015/20150319-3.html>
- [Garrich-ECOC12] M. Garrich, N. Amaya, G. Zervas, P. Giaccone, and D. Simeonidou, "Power consumption analysis of architecture on demand", European Conference and Exposition on Optical Communication (ECOC), 2012, P5.06.
- [Garrich-OFC14] M. Garrich, J.R.F.Oliveira, M. Siqueira, N. Amaya, G.S. Zervas, D. Simeonidou, "Flexibility of Programmable Add/Drop Architecture for ROADMs", Optical Fiber Communication Conference and Exposition (OFC), 2014, W1C.2.
- [Garrich-ONDM12] M. Garrich, N. Amaya, G. Zervas, P. Giaccone, and D. Simeonidou, "Architecture on demand: Synthesis and scalability", International Conference on Optical Network Design and Modeling (ONDM), 2012, pp. 1–6.
- [Gestrel-ComMag12] O. Gerstel, M. Jinno, A. Lord, S.J.B. Yoo, "Elastic optical networking: a new dawn for the optical layer?", IEEE Communications Magazine, vol. 50, no. 2, pp. s12 – s20, February 2012.
- [Gonzalez-ECOC15] O. Gonzalez de Dios, R. Casellas, F. Paolucci, A. Napoli, Ll. Gifre, S. Annoni, S. Belotti, U. Feiste, D. Rafique, M. Bohn, S. Bigo, A. Dupas, E. Duttisseuil F. Fresi, B. Guo, E.Hugues-Salas, P. Layec, V. López, G. Meloni, S. Misto, R. Morro, T. Rahman, G. Khanna, R. Martínez, R. Vilalta, F. Cugini, L. Potì, A. D'Errico, R. Muñoz, Y. Shu, S. Yan, Y. Yan, G. Zervas, R. Nejabati, D. Simeonidou, L. Velasco and J. Fernández-Palacios, "First Demonstration of Multi-vendor and Multi-domain EON with S-BVT and Control Interoperability over Pan-European Testbed", European Conference and Exposition on Optical Communication (ECOC), 2015, PDP 4.1.
- [Gringeri-ComMag10] S. Gringeri, B. Basch, V. Shukla, R. Egorov, T.J. Xia, "Flexible architectures for optical transport nodes and networks", IEEE Communication. Magazine vol.48, no 7, pp.40-50, July 2010.
- [Guckenberger-ECOC10] D. Guckenberger, S. Abdalla, C. Bradbury, J. Clymore, P. De Dobbelaere, D. Foltz, S. Gloeckner, M. Harrison, S. Jackson, D. Kucharski, Y. Liang, C. Lo, M. Mack, G. Masini, A. Mekis, A. Narasimha, M. Peterson, T. Pinguet, J. Redman, S. Sahni, N. Welch, K. Yokoyama, S. Yu, "Advantages of CMOS Photonics for Future Transceiver Applications", European Conference and Exposition on Optical Communication (ECOC), 2010, Tu.4.C.2.
- [Hugues-Salas-ComMag15] E. Hugues-Salas, G. Zervas, D. Simeonidou, E. Kosmatos, T. Orphanoudakis, A. Stavdas, M. Bohn, A. Napoli, T. Rahman, F. Cugini, N. Sambo, S. Frigerio, A. D'Errico, A. Pagano, E. Riccardi, V. López, J. P. Fernández-Palacios Giménez, "Next Generation Optical Nodes: The Vision of the European Research Project IDEALIST", IEEE Communications Magazine, Vol. 53, No. 2, pp. 172 – 181, February 2015.
- [IDEALIST-D1.3] IDEALIST Deliverable D1.3: "Preliminary results and improvement of reference scenarios".
- [IDEALIST-D1.5] IDEALIST Deliverable D1.5: "Evaluation of flexgrid technologies".
- [IDEALIST-D1.6] IDEALIST Deliverable D1.6: "Lessons and conclusions from elastic optical



networks”.

- [IDEALIST-D2.1] IDEALIST Deliverable D2.1: “Assessment of all potential flexgrid/flexrate data plane technologies including transmission & switch”.
- [IDEALIST-D2.2] IDEALIST Deliverable D2.2: “Modelling and experimental work on the chosen flexgrid/flexrate technology options”.
- [IDEALIST-D2.3] IDEALIST Deliverable D2.3: “Data plane designs for implementation and further experimental evaluation”.
- [IDEALIST-D3.2] IDEALIST Deliverable D3.2: “Design and Evaluation of the Adaptive Network Manager and Functional Protocol Extensions”.
- [IDEALIST-D3.3] IDEALIST Deliverable D3.3: “Final report on the adaptive network manager and GMPLS control plane”.
- [IDEALIST-D6.4] IDEALIST Deliverable D6.4: “Idealist Exploitation Plan”.
- [Inan-ECOC10] B. Inan, S. Randel, S.L. Jansen, A. Lobato, S. Adhikari, N. Hanik, “Pilot-Tone-based Nonlinearity Compensation for Optical OFDM Systems”, European Conference and Exposition on Optical Communication (ECOC), 2010, Tu.4.A.6.
- [Infinera-1] https://www.infinera.com/wp-content/uploads/2015/06/Infinera_Product_Brochure.pdf
- [Infinera-2] <https://www.infinera.com/infinera-introduces-two-new-photonic-integrated-circuits-to-support-new-layer-c-and-layer-t-network-model/>
- [ITU-T G.694.1] ITU-T Recommendation, “Spectral grids for WDM applications: DWDM frequency grid”, ITU-T, February 2012.
- [ITU-T-G.698.2] ITU-T Recommendation, “Amplified multichannel dense wavelength division multiplexing applications with single channel optical interfaces”, November 2009.
- [ITU-T-G.709] ITU-T Recommendation, “Interfaces for the optical transport network”, February 2012.
- [JDSU-1] <https://www.lumentum.com/en/products/trueflex-1x9-wavelength-selective-switch>
- [JDSU-2] <https://www.lumentum.com/en/products/trueflex-twin-high-port-count-wavelength-selective-switch-twin-wss>
- [JDSU-3] <https://www.lumentum.com/en/products/trueflex-fs-optical-channel-monitor-ocm>
- [JDSU-4] <https://www.lumentum.com/en/products/trueflex-twin-multi-cast-switch-mcs>
- [Jianjun-ECOC15] J. Yu, J. Zhang, Z. Jia, X. Li, H. Chang Chien, Y. Cai, F. Li, Y. Wang, X. Xiao, “Transmission of 8x128.8Gbaud Single-Carrier PDM-QPSK Signal over 2800km SMF-28 with EDFA-only”, European Conference and Exposition on Optical Communication (ECOC) 2015, P.1.1.
- [Jinno-ComMag09] M. Jinno, H. Takara, B. Kozicki, Y. Tsukishima, Y. Sone, and S. Matsuoka, “Spectrum-efficient and scalable elastic optical path network: Architecture, benefits, and enabling technologies”, IEEE Communication Magazine, vol. 47, no. 11, pp. 66–73, 2009.
- [Jinno-ComMag12] M. Jinno, H. Takara, Y. Sone, K. Yonenaga, A. Hirano, “Multiflow optical transponder for efficient multilayer optical networking”, Communications Magazine, IEEE, vol. 50, no. 5, p. 56 – 65, 2012.
- [Kosmatos-ECOC14] E. Kosmatos, T. Orphanoudakis, C. Matrakidis, A. Stavdas, A. Lord, “Switchless Elastic Rate Node (SERANO) Architecture for Flexgrid and Elastic Rate Networks”, European Conference and Exposition on Optical Communication (ECOC) 2014, Mo.4.2.2



- [Kozicki-OptE10] B. Kozicki, H. Takara, Y. Tsukishima, T. Yoshimatsu, K. Yonenaga, and M. Jinno, "Experimental demonstration of spectrum-sliced elastic optical path network (SLICE)", OSA, Optics Express, vol. 18, no. 21, 2010.
- [Kuschnerov-JLT09] M. Kuschnerov, F.N. Hauske, K. Piyawanno, B. Spinnler, M.S. Alfiad, A. Napoli, B. Lankl, "DSP for Coherent Single-Carrier Receivers", Lightwave Technology, Journal of , vol.27, no.16, pp.3614-3622, Aug.15, 2009.
- [Kuschnerov-PJ10] M. Kuschnerov, M. Chouayakh, K. Piyawanno, B. Spinnler, E. De Man, P. Kainzmaier, M.S. Alfiad, A. Napoli, B. Lankl, "Data-Aided Versus Blind Single-Carrier Coherent Receivers", IEEE Photonics Journal, vol.2, no.3, pp.387,403, June 2010.
- [Layec-ECOC-14] P. Layec, A. Ghazisaeidi, G. Charlet, J. Antona, S. Bigo. "A novel compensation method at the receiver for cross-polarization modulation effects", European Conference on Optical Communication (ECOC), 2014, Th2.3.5.
- [Lopez-JOCN14] V. López, B. de la Cruz, O. Gonzalez de Dios, O. Jerstel, N. Amaya, G. Zervas, D. Simeonidou. J.P. Fernandez Palacios, "Finding the target cost for sliceable bandwidth variable transponders", Journal of Optical Communications and Networking, Vol. 6, No. 5, p. 476 – 485, 2014.
- [Mardoyan-OFC15] H. Mardoyan, R. Rios-Müller, M.A. Mestre, P. Jennevé, L. Schmalen, A. Ghazisaeidi, P. Tran, S. Bigo, J. Renaudier. "Transmission of Single-Carrier Nyquist-Shaped 1-Tb/s Line-Rate Signal over 3,000 km", Optical Fiber Communication Conference and Exposition (OFC), 2015., pp. W3G.2.
- [Morea-JOCN15] A. Morea, J. Renaudier, T. Zami, A. Ghazisaeidi, O. Bertran-Pardo. "Throughput Comparison Between 50-GHz and 37.5-GHz Grid Transparent Networks [Invited]", IEEE Journal of Optical Communications and Networking Vol. 7, No. 2, pp A293-A300, 2015.
- [Muhammad-JOCN14] A. Muhammad, G. Zervas, N. Amaya, D. Simeonidou, R. Forchheimer, "Introducing Flexible and Synthetic Optical Networking: Planning and Operation Based on Network Function Programmable ROADMs", IEEE Journal of Optical Communications and Networking, Vol. 6, No. 7, pp. 635 – 648, July 2014.
- [Murakami-ICTON09] M. Murakami, K. Oda, "Power consumption analysis of optical cross-connect equipment for future large capacity optical networks", IEEE Transparent Optical Networks (ICTON), 2009, pp. 1–4.
- [Napoli-JLT14] A. Napoli, Z. Maalej, V. AJM Sleiffer, M. Kuschnerov, D. Rafique, E. Timmers, B. Spinnler, T. Rahman, L. Didier Coelho, N. Hanik. "Reduced complexity digital back-propagation methods for optical communication systems", IEE Journal of Lightwave Technology Vol. 32, No. 7, 1351-1362, 2014.
- [Nadal-JLT14] L. Nadal, M. Svaluto Moreolo, J. M. Fabrega, A. Dohhan, H. Griesser, M. Eiselt, J. Elbers, "DMT Modulation with Adaptive Loading for High Bit Rate Transmission Over Directly Detected Optical Channels", IEEE Journal of Lightwave Technology, Vol. 32, No. 21, pp. 3541 – 3551, November 2014.
- [Nespola-OFC15] A. Nespola, M. Huchard, G. Bosco, A. Carena, Y. Jiang, P. Poggiolini, F. Forghieri. "Experimental validation of the EGN-model in uncompensated optical links", Optical Fiber Communication Conference and Exposition (OFC), 2015, Th4D-2.
- [Oclaro] <http://www.oclaro.com/product/coherent-cfp2-aco/>
- [OIF-2015] <http://www.oiforum.com/wp-content/uploads/OIF-Tech-Options-400G-01.0.pdf>
- [Paolucci-JOCN14] F. Paolucci, F. Cugini, F. Fresi, G. Meloni, A. Giorgetti, N. Sambo, L. Potí, A. Castro, L. Velasco, P. Castoldi, "Superfilter technique in SDN-controlled elastic optical networks [Invited]", IEEE Journal of Optical Communications and



- Networking, Vol.7, No.2, pp.A285 – A292, February 2015.
- [Peters-OFC15] A. Peters, E. Hugues-Salas, G. Zervas, D. Simeonidou, "Measuring Flexibility and Design Trade-offs of NxM SSS-based ROADMs and BVTs" Optical Fiber Communication Conference and Exposition (OFC), 2015, W3J.5.
- [Poggiolini-PTL11] P. Poggiolini, G. Bosco, A. Carena, V. Curri, V. Miot, F. Forghieri "Performance Dependence on Channel Baud-Rate of PM-QPSK Systems Over Uncompensated Links", IEEE Photonics Technology Letters, Vol.23, No.1, pp.15 – 17, January 2011.
- [Poggiolini-PTL11-2] P. Poggiolini, A. Carena, V. Curri, G. Bosco, F. Forghieri, "Analytical Modeling of Non-Linear Propagation in Uncompensated Optical Transmission Links", IEEE Photonics Technology Letters, Vol.23, No.11, pp. 742 – 744, March 2011.
- [Poggiolini-JLT12] P. Poggiolini, "The GN Model on Non-linear Propagation in Uncompensated Coherent Optical Systems", IEEE Journal of Lightwave Technology, Vol.30, No.24 pp. 3857 – 3879, September 2012.
- [Poggiolini-JLT14] P. Poggiolini G. Bosco, A. Carena, V. Curri, Y. Jiang, F. Forghieri, "The GN-Model of Fiber Non-Linear Propagation and its Applications", IEEE Journal of Lightwave Technology, Vol. 32, No.4, pp. 694 – 721 2014.
- [Poole-OFC11] S. Poole, S. Frisken, M. Roelens, C. Cameron, "Bandwidth-flexible ROADMs as network elements", Optical Fiber Communication Conference and Exposition (OFC), 2011, pp.1-3.
- [Rahman-ECOC14] T. Rahman, D. Rafique, A. Napoli, E. de Man, M. Kuschnerov, B. Spinnler, M. Bohn, C. M. Okonkwo, H. de Waardt. "FEC overhead optimization for long-haul transmission of PM-16QAM based 400Gb/s super-channel", European Conference on Optical Communication (ECOC), 2014, P.5.17.
- [Rahman-ECOC15] T. Rahman, D. Rafique, B. Spinnler, A. Napoli, H. de Waardt, "1, 32 x 1Tb/s C-band Transmission over 1000km employing Three Subcarriers PM-64QAM for Regional Applications", European Conference on Optical Communication (ECOC) 2015, Tu.1.4.5.
- [Rahman-JLT15] T. Rahman, D. Rafique, A. Napoli, E. de Man, B. Spinnler, M. Bohn, C.M. Okonkwo, A.M.J. Koonen, H. de Waardt. "Ultralong Haul 1.28-Tb/s PM-16QAM WDM Transmission Employing Hybrid Amplification", IEEE Journal of Lightwave Technology Vol.33, No. 9, pp. 1794 – 1804, 2015.
- [Rahman-OEC C15] T. Rahman, D. Rafique, B. Spinnler, E. Pincemin, C. Le Bouëtté, J. Jauffrit, S. Calabro et al., "Record Field Demonstration of C-band Multi-Terabit 16QAM, 32QAM and 64QAM over 762km of SSMF", OptoElectronics and Communications Conference (OECC) 2015.
- Rahman-PhSw15] T. Rahman, A. Napoli, G. Meloni, F. Fresi, L. Poti, N. Sambo, D. Rafique, M. Nölle, C. Schubert, M. Bohn, "Experimental Comparison of 1.28 Tb/s Nyquist WDM vs. Time-Frequency Packing", Photonics in Switching, September 2015.
- [Raybon-IPC12] G. Raybon, S. Randel, A. Adamiecki, P.J. Winzer, L. Salamanca, R. Urbanke, S. Chandrasekhar, A. Konczykowska, F. Jorge, J. Dupuy, L.L. Buhl, S. Draving, M. Grove, K. Rush, "1-Tb/s dual-carrier 80-Gbaud PDM-16QAM WDM transmission at 5.2 b/s/Hz over 3200 km", IEEE Photonics Conference (IPC), 2012, pp. 23 – 27.
- [Raybon-ECOC13] G. Raybon, A. Adamiecki, P.J. Winzer, M. Montoliu, S. Randel, A. Umbach, M. Margraf et al., "All-ETDM 107-Gbaud PDM-16QAM (856-Gb/s) transmitter and coherent receiver", European Conference on Optical Communication (ECOC) 2013.



- [Raybon-JLT14] G. Raybon, A. Adamiecki, P.J. Winzer, S. Randel, L. Salamanca, A. Konczykowska, F. Jorge, J. Dupuy, L.L. Buhl, S. Chandrashekar, X. Chongin, S. Dravin, M. Grove, K. Rush, R. Urbanke "High symbol rate coherent optical transmission systems: 80 and 107 Gbaud", IEEE Journal of Lightwave Technology, Vol. 32, No. 4, pp.824 – 831, 2014.
- [Renaudier-ECOC13] J. Renaudier, R. Rios-Muller, L. Schmalen, M. Salsi, P. Tran, G. Charlet, S. Bigo, "1-Tb/s transceiver spanning over just three 50-GHz frequency slots for long-haul systems", European Conference on Optical Communication (ECOC) 2013, pp 1 – 3.
- [Renaudier-ECOC13-2] J. Renaudier, A. Ghazisaeidi, P. Tran, O. Bertran-Pardo, G. Charlet, S. Bigo, "Long haul transmission of 1Tbps superchannel, 175GHz spaced over SSMF using Nyquist pulse shaping and flexgrid WDM architecture", European Conference on Optical Communication (ECOC) 2013, Th.2.D.5.
- [Riccardi-EUCNC15] E. Riccardi, A. Pagano, N. Sambo, P. Castoldi, A. D'Errico, M.S. Moreolo, J.M. Fabrega, D. Rafique, A. Napoli, M. Bohm, E.H. Salas, G. Zervas, D. Simeonidou T. Rahaman, M. Gunkel, "Sliceable bandwidth variable transponder: the IDEALIST vision", European Conference On Network And Comunication (EUCNC), 2015, pp, 330 – 334.
- [Sambo-ComMag15] N. Sambo, P. Castoldi, A. D'Errico, E. Riccardi, A. Pagano, M.S. Moreolo, J.M. Fabrega, D. Rafique, A. Napoli, S. Frigerio, E.H. Salas, G. Zervas, M. Nolle, J.K. Fischer, A. Lord, J.P.F. Gimenez, "Next generation sliceable bandwidth variable transponders", IEEE Communications Magazine, Vol.53, No.2, pp.163 – 171, February 2015.
- [Sambo-JLT14] N. Sambo, G. Meloni, F. Paolucci, F. Cugini, M. Secondini, F. Fresi, L. Poti, P. Castoldi, "Programmable Transponder, Code and Differentiated Filter Configuration in Elastic Optical Networks",IEEE Journal of Lightwave Technology, Vol.32, No.11, pp. 2079 – 2086, June 2014.
- [Sambo-JOCN13] N. Sambo, G. Meloni, G. Berrettini, F. Paolucci, A. Malacarne, A. Bogoni, F. Cugini, L. Poti, P. Castoldi, "Demonstration of data and control plane for optical multicast at 100 and 200 Gb/s with and without frequency conversion", IEEE Journal of Optical Communications and Networking, Vol.5, No.7, pp. 667 – 676, July 2013.
- [Sambo-JOCN14] N. Sambo, A. D'Errico, C. Porzi, V. Vercesi, M. Imran, F. Cugini, A. Bogoni, L. Poti, P. Castoldi, "Sliceable transponder architecture including multiwavelength source", IEEE Journal of Optical Communications and Networking, Vol.6, No.7, pp. 590 – 600, July 2014.
- [Sambo-OFC15] N. Sambo, G. Meloni, F. Cugini, A D'Errico, L. Poti, P. Iovanna, P. Castoldi,, "Routing, code, and spectrum assignment (RCSA) in elastic optical networks", Optical Fiber Communications Conference and Exhibition (OFC), 2015, W1.i.1.
- [Secondini-JLT15] M. Secondini, T. Foggi, F. Fresi, G. Meloni, F. Cavaliere, G. Colavolpe, E. Forestieri, L. Poti, R. Sabella, G. Prati, "Optical Time-Frequency Packing: Principles, Design, Implementation, and Experimental Demonstration", IEEE Journal of Lightwave Technology, Vol. PP, No.99, pp.1,1., 2015.
- [Svaluto-ECOC13] M. Svaluto Moreolo, J. M. Fabrega, F. J. Vilchez, L. Nadal, V. López, G. Junyent, "Experimental Validation of an Elastic Low-Complex OFDM-Based BVT for Flexi-Grid Metro Networks", European Conference and Exhibition on Optical Communication (ECOC), 2013, We.1.E.
- [Svaluto-ECOC14] M. Svaluto Moreolo, J. M. Fabrega, F. J. Vilchez, K. Christodoulopoulos, E. Varvarigos, V. López, J. P. Fernández-Palacios, "Assessment of Flexgrid Technologies in the MAN for Centralized BRAS Architecture Using S-BVT",



- European Conference and Exhibition on Optical Communication (ECOC), 2014, P.6.9.
- [Svaluto-ONDM14] M. Svaluto Moreolo, J. M. Fabrega, L. Nadal, F. J. Vilchez, V. López, J. Pedro Fernández-Palacios, “Cost-Effective Data Plane Solutions Based on OFDM Technology for Flexi-Grid Metro Networks Using Sliceable Bandwidth Variable Transponders”, International Conference on Optical Networking Design and Modeling (ONDM), 2014, pp. 281 -286.
- [TEEM] Teem Photonics, “Metro EDWA Series” datasheet, October 2002.
- [Wang-Comms&T12] Y.Wang and X. Cao, “Multi-granular optical switching: A classified overview for the past and future,” IEEE Communication. Surveys and Tutorials, Vol. 14, No. 3, pp. 698 – 713, 2012.
- [Way-OFC12] W.I Way., “Optimum architecture for M x N multicast switch-based colorless, directionless, contentionless, and flexible-grid ROADM”, Optical Fiber Communication Conference and Exposition (OFC), 2012, NW3F.5.
- [Yuan-OFC15] Hui Yuan, Miquel Garrich Alabarce, Emilio Hugues-Salas, Georgios Zervas, Dimitra Simeonidou, “Function Placement and Configuration for Power Balanced Network Function Programmable Optical Nodes”, Optical Fiber Communication Conference and Exposition (OFC), 2015. W3J.2.



1.3 Acronyms

ABNO	Application-Based Network Operations
ACO	Analog Coherent Optics
ADC	Analog to Digital Converter
AFC	Automatic Frequency Control
AoD	Architecture on Demand
ASE	Amplified Spontaneous Emission
ASIC	Application Specific Integrated Circuit
AWGN	Additive White Gaussian Noise
BCJR	Bahl-Cocke-Jelinek-Raviv detector
BER	Bit Error Rate
BPSK	Binary Phase Shift keying
BRAS	Broadband Remote Access Server
BV	Bandwidth Variable
BVT	BV Transponder
BV-WSS (or SSS)	Bandwidth Variable Wavelength Selective Switches (or Spectrum Selective Switches)
CapEx	Capital Expenditure
CAZAC	Constant Amplitude and Zero AutoCorrelation
CD	Chromatic Dispersion
CDC	Colorless Directionless Contentionless Add Drop
CFP	C Form-factor Pluggable
CMOS	Complementary Metal-Oxide Semiconductor
CO	Coherent
DAC	Digital to Analog Converter
DD	Direct Detection
DES	Discrete Event Simulator
DFB	Distributed Fiber Bragg grating
DFC	Differentiated Filter Configuration
DGD	Differential Group Delay
DMT	Discrete MultiTone
DP (or PM)	Dual Polarization (or Polarization Modulation)
DPE	Digital Pre Emphasis
DSP	Digital Signal Processing



DVFS	Dynamic Frequency and Voltage Scaling
DWDM	Dense WDM
DXC	Digital Cross Connect
EDFA	Erbium Doped Fiber Amplifier
EDWA	Erbium Doped Wavelength Amplifier
ENOB	Effective Number Of Bits
EON	Elastic Optical Network
EVMHit_Ratio	Error Vector Magnitude Hit Ratio
EXC	Elastic Cross Connect
FEC	Forward Error Correction
Flex-OXC	Flexible OXC
FPGA	Field Programmable Gate Array
FSU	Frequency Slot Unit
FWM	Four Waves Mixing
GbE	Gigabit Ethernet
GN	Gaussian Noise
GNRF	Gaussian Noise Reference Formula
GUI	Graphical User Interface
HD	Hard Decision
ICI	Inter-Carrier Interference
IDEALIST	Industry-Driven Elastic And Adaptive Lambda Infrastructure For Service And Transport Networks
IM	Intensity Modulation
IEEE	Institute of Electric and Electronic Engineers
IETF	Internet Engineering Task Force
InP	Indium Phosphide
I/O	Input/Output
IP	Internet Protocol
IQ	In Phase-Quadrature
ISI	Inter Symbol Interference
ITU-T	International Telecommunication Union-Telecommunication Standardization Sector
HD	Hard Decision
LASER	Light Amplification by Stimulated Emission of Radiation
LcoS	Liquid Cristal on Silicon



LDPC	Low-Density Parity-Check
MAN	Metro Area Networks
MCS	MultiCast Switch
MOD	MODulators
MPLS	MultiProtocol Label Switching
MSE	Mean Squared Error
MTU	Multi Tenant Unit
MW	Multi Wavelength
MZM	Mach-Zehnder Modulator
ND	Nodal Degree
NF	Noise Figure
NWDM	Nyquist Wavelength Division Multiplexing
OAM	Operations, Administration and Management
Och	Optical Channel
ODU	Optical Digital Unit
ODUn	ODU of order N
ODUCn	ODU 100G of order N
ODUFlex	Flexible ODU
O/E/O	Optical- Electrical- Optical regeneration
OFDM	Orthogonal Frequency Division Multiplexing
OH	OverHead
OIF	Optical Internetworking Forum
OLA	Optical Line Amplifier
OLO	Other Licensed Operators
OMS	Optical Multiplexing Section
OOK	Optical On-Off Keying (equivalent to Intensity Modulation)
OpEx	Operating Expense
OPU	Optical Payload Unit
OSA	Optical Spectrum Interface
OSNR	Optical Signal to Noise Ratio
OTN	Optical Transport Network
OTU	Optical Transport Unit
OTUCn	OTU 100G of order N
OXC	Optical Cross Connect



PAPR	Peak to Average Power Ratio
PCE	Path Computation Element
PIC	Photonic Integrated Circuit
PPLN	Periodically Poled Lithium Niobate
PSE	Photonic Service Engine
QoT	Quality of Transmission
QPSK	Quadrature Phase Shift Keying
QAM	Quadrature Amplitude Modulation
ROADM	Reconfigurable Optical Add Drop Multiplexer
RMFSA	Routing Modulation format Frequency and Spectrum Assignment
RMSA	Routing Modulation format and Spectrum Assignment
RX	Receiver
S-BVT	Sliceable-BVT
SD	Soft Decision
SD-FEC	Soft Decision FEC
SDM	Spatial Division Multiplexing
SDN	Software Defined Network
SE	Spectral Efficiency
SERANO	Switchless Elastic Rate Node
SLA	Service Level Agreement
SMF	Single Mode optical Fiber
SNR	Signal to Noise Ratio
SOI	Silicon On Insulator
SSB	Single Side Band
SSS (or BV- WSS)	Spectrum Selective Switch
TFP	Time Frequency Packing
TX	Transmitter
WDM	Wavelength Division Multiplexing
WP	Work Package
WSS	Wavelength Selective Switch

1.4 Document history

Version	Date	Authors	Comments
Draft v.1	19.05.2015	Emilio Hugues-Salas	ToC, some guidelines
Draft v.2	14.07.2015	Emilio Riccardi, Anna Chiadò Piat	New Toc after discussion of IDEALIST technological roadmap and network evolutionary deployment
Draft v.3	30.07.2015	Josep M. Fabrega, Michela Svaluto, Laura Martín González	OFDM in chapter 4 and first draft of chapter 5
Draft v.4	30.07.2015	Nicola Sambo, Filippo Cugini, Antonio D'Errico, Matthias Gunkel	TFP in SBVT Sec., Control and Monitoring, List of parameters for inter-operability, Defragmentation, Advanced control and monitoring
Draft v.5	05.09.2015	Emilio Riccardi, Anna Chiadò Piat	Data plane technology state of the art
Draft v.6	10.09.2015	Emilio Riccardi, Anna Chiadò Piat	Section 3
Draft v.7	01.10.2015	Emilio Hugues-Salas, Alexandros Stavdas	Updated sections 4.2, 5.2, 6.1, 6.2, and 6.3
Draft v.8	05.10.2015	Emilio Riccardi, Anna Chiadò Piat	Document overview, List of Acronyms
Draft v.9	06.10.2015	Emilio Riccardi, Anna Chiadò Piat	Section 1.5
Draft v.10	08.10.2015	Patricia Layec, Chris Matrakidis	Sections 4.3.2, 5.1 and 6.3.1
Draft v.11	08.10.2015	Markus Noelle, Antonio D'Errico	Sections 4.6 and 4.7
Draft v.12	20.10.2015	Josep M. Fabrega, Nicola Sambo	Sections 4.6 and 6.4
Draft v.13	23.10.2015	Emilio Hugues-Salas, Emilio Riccardi, Anna Chiadò Piat, Antonio Napoli, Josep M. Fabrega, Nicola Sambo	Updated all the section of the document including the introductory section and the Appendix
Draft v.14	25.10.2015	Emilio Riccardi	First general review of the document
Draft v.15	26.10.2015	Anna Chiadò Piat, Emilio Riccardi	Consistent formatting of References



Draft v.16	27.10.2015	Nicola Sambo	Review
v.17	28.10.2015	Emilio Hugues-Salas, Antonio Napoli, Nicola Sambo, Emilio Riccardi	First complete version of the document
v.18	28.10.2015	Nicola Sambo	Review
v.19	08.11.2015	Andrew Lord	Review with some comments
v.20	10.11.2015	Emilio Riccardi, Emilio Hugues-Salas	Reviewed and updated version



1.5 Document overview

The document starts with two introductory sections: the Executive Summary, which offers a concise summary of the content of the document, and the Introduction chapter itself (Section 1), which includes the scope of the document, the list of acronyms, the quoted references and the document editorial history.

The core of the document is then organized into six chapters plus an appendix. The structure is as follows:

- **Chapter 2** provides a brief overview of the state of the art of the elastic optical network (EON) related market.

Indeed, starting from components and subsystems to complete transmission systems, different suppliers are introducing or have already introduced in the market products such as flexgrid ROADM components and subsystems and flexrate line interface modules or subsystems that can be used to build EONs.

The chapter includes also a brief report of standardization activities, focusing mainly on the ITU-T, which is devoted to “beyond 100G OTN” and “black link” issues. Both are hot topics for the introduction of the EON paradigm in operator’s networks.

Finally, a recent OIF 400G White Paper document is briefly discussed in relation to the proposed IDEALIST short and medium term data plane solution.

- **Chapter 3** is dedicated to the IDEALIST vision regarding the evolution of the EON and the gradual introduction into the market of IDEALIST data plane solutions.

A first block of the IDEALIST solutions is expected to be well consolidated and widespread in the market indicatively within 2017/18, comprising line interfaces with variable rates ranging from 100Gbit/s to 400Gbit/s, in some cases with modular or sliceable solutions. For super-channel generation and transmission, the Nyquist WDM technique will be certainly the dominant employed solution.

An improved second generation of the data plane solution will be probably available by 2021. Sustainable capacity upgrade will be made possible by technological enhancement in footprint and power consumption, enabling the development of cost and power effective 1Tbit/s, followed by sliceable BVT. The implementation of new and more efficient ASICs is expected, for both flexibility (e.g. 25G instead of 100G steps in transmission capacity, hybrid modulation format, etc.), and performance (e.g. non-linear impairment mitigation, next generation FEC, etc.); also, products implementing new advanced transmission techniques such as TFP and OFDM may be possibly introduced by some vendor for specific network use cases or demanding applications.

The ROADM architecture will probably still be based on traditional broadcast and select or switch and select schemes, but LCoS technology BV-WSSs will enable flexgrid. Some improvements and optimization in term of cost and footprint are expected mainly for the Add&Drop functionalities.

An effective technological breakthrough will be needed only when the traditional node architecture will be no longer able to support traffic growth, an event not believed to happen in the short or medium term time frame. To overcome the limitations of traditional node architectures, an interesting long term candidate is represented by the flexible Architecture on Demand (AoD) together with other innovative ideas developed within IDEALIST for efficiently cope with very big and dynamic traffic loads.

- **Chapter 4** discusses more deeply the short and medium term desired and expected solutions for (S)-BVTs and novel node architectures.

Section 4.1 comments on and updates the IDEALIST initial hypothesis regarding node capacity, reach and flexibility, reported in Table 2.6 of deliverable D2.1.

Section 4.2 is about ROADM architecture, expected to remain compliant with traditional broadcast and select or switch and select fixed grid solution while effectively introducing flexgrid.

In section 4.3 the main features of flexible transponders are reported: in the short term (2017/18) variable rate between 100Gbit/s and 400Gbit/s super-channels, with 1 to 4 Nyquist shaped sub-carriers and optional sliceability are expected; in the mid-term (2021) Nyquist transmission performance will be enhanced thanks to the expected new generation of ASIC, enabling more powerful digital signal processing techniques such as, for example, the adoption of performing advanced non-linear mitigation algorithms. Also other transmission techniques such as TFP and OFDM transmission techniques are believed to be available.

Section 4.4 deals with control and monitoring. First, relevant transmission parameters, the programmability of S-BVT parameters, and the switching control are discussed. Then, a sub-paragraph about monitoring reports a list of network elements, and of the correspondent physical quantities to be monitored in order to be able to detect and localize failures.

In section 4.5 the most relevant parameters that must be standardized in order to achieve multivendor interoperability are addressed.

Section 4.6 describes activities and results concerning the derivation and implementation of tools allowing assessing the system performance of a flexgrid data plane in an efficient and fast way. These tools are mainly based on the Gaussian Noise (GN) model.

Lastly, section 4.7 gives a detailed explanation of the technological evolution that, in the next few years, will enable the development of 1Tbit/s S-BVTs, sustainable in terms of footprint, power consumption and costs.

- **Chapter 5** discusses present and future IDEALIST metro area network solutions for elastic interfaces and nodes for medium to long term.

Section 5.1 describes the OTN current scenario and the requirements for the future flexgrid vision. Details of the “beyond-100G-OTUflex” definition work is described as well as part of the contributions to ITU from the IDEALIST project. Moreover, the first worldwide prototype of the Beyond-100G-OTUflex concept is described as one of the main outputs of the project.

From the node point of view, in section 5.2 a brief description of today’s node functionalities is declared together with the requirements and limitations for flexgrid nodes in metro and metro/core border node applications. A long-term solution is proposed with the use of flexible and scalable nodes which are easy adaptable to different metro traffic changes.

Moreover, in section 5.3, a solution for traffic aggregation in the metro/regional network domain is presented. In this section, the use of S-BVTs is proposed to optically aggregate in a flexgrid network the data flows coming from the MTUs towards those



sites where BRASes are located. In addition, the description of different architectures of S-BVTs for a MAN scenario with centralized BRASes is provided.

- **Chapter 6** provides methodologies and solutions for future long-term EONs. Section 6.1 introduces a figure of merit for flexibility to design future EONs. This figure of merit is also related to other figures of merit with the purpose of providing a generic view to the network designer of the possible EON network configurations. Section 6.2 provides the long-term solution for elastic optical nodes. Namely, the architecture on demand (AoD) node is presented and its main benefits are discussed. Section 6.3 includes regeneration and defragmentation options. On the one hand, these options are provided for the SERANO node solution, where several algorithms are provided to describe the capabilities and functionalities of this node. On the other hand, a defragmentation technique, named “push-pull”, has been proposed and demonstrated. With this technique, the signal can be shifted in the frequency domain hitlessly. Finally, long-term solutions for internal control and monitoring are provided in this chapter. These solutions have been exploited within IDEALIST for recovery purposes. Advanced DSP with monitoring functionalities are employed to address the occurrence of events with a new hitless dynamic adaptation technique.
- **Chapter 7** concludes the deliverable.
- **Appendix** is added to allow a place to house relevant recent results not already included in others WP2 deliverables, or to deepen technical details omitted in the main text for easy reading.



2 Data plane technology state of the art

In order to better clarify the context in which the IDEALIST final proposal for the EON data plane solution is defined, we report in this chapter the most significant already commercially available technologies, and the most relevant achievements obtained by standardization bodies related to optical transmission.

2.1 Commercially available technologies

In this subsection, a brief overview of the EON related market is given; examples are cited although they certainly do not cover everything that the market is offering. Furthermore, in collecting the information for this chapter, only public domain material - updated approximately up to September 2015 - has been used.

Starting the listing from components and subsystems, many suppliers are introducing, or have already introduced in the market, flexgrid ROADMs components and subsystems, flexrate line interface modules or subsystems that can be employed inside EON equipment.

More specifically, regarding flexgrid ROADMs, for example, Finisar and JDSU (Lumentum) provide 1x9 and 1x20 flexgrid WSSs [Finisar-1] [JDSU-1]. In all cases LCoS technology is employed providing dynamic control of the channel center frequency with 6.25 GHz resolution and channel width with 12.5 GHz resolution. Frequency slot edges are aligned to the 12.5 GHz ITU grid, offering full backwards compatibility with both the standard 100 GHz and 50 GHz ITU grids.

Some vendors are also introducing Nx20 WSSs (N=2) or double 1x20WSSs in the same case with the purpose of gaining a footprint reduction [JDSU-2].

Other relevant components for flexgrid ROADMs are channel power monitoring [JDSU-3] to finely equalize super-channels and multicast switches for contentionless add and drop. Current products are equipped with up to 16 drop ports [JDSU-4] [DiCon].

In addition, regarding flexrate interface modules, some new products are emerging. For instance Oclaro [Oclaro], Fujitsu [Fujitsu PR-2015] and Finisar [Finisar-2] have recently declared almost available a 100Gbit/s DP-QPSK / 200Gbit/s DP-16QAM ACO (*Analog Coherent Optics*) pluggable CFP2 module, with tunable lasers across the C-band. In all cases CFP2 packaging is notable for enabling high density line card applications, with reduced power consumption and installation costs. ACO are enabling components for coherent interfaces, mainly targeted to the metro regional market.

Digital ASICs for DSP functionality up to 400Gbit/s are starting to appear in the market. For example, Clariphy is introducing a DSP ASIC for 200Gbit/s optical transmission [Clariphy].

Moreover, Acacia, has announced the availability of the AC400: a coherent 5"x7" transceiver module, supporting two optical channels and three modulation formats: DP-QPSK, DP-8QAM and DP-16QAM, enabling a total rate ranging from 100Gbit/s to 400Gbit/s [Acacia PR-2015]. Reduction in size and power consumption are pursued also in this case, where DSP and SD-FEC processing for the two channels have been developed on a dual core dedicated ASIC.



Another 5"x7" flexrate coherent optical transponder (FTLC3311x3yL) has been declared available by Finisar [Finisar-3], supporting 200Gbit/s DP-16QAM, 100Gbit/s DP-QPSK, and 40Gbit/s DP-BPSK, for a reach of 500km, 2500km and 5000km, respectively.

Moving from component to full transmission systems, flexrate line interfaces are also being provided by several system vendors.

For example, Alcatel-Lucent is introducing in the market new line interfaces with a net capacity reaching 400Gbit/s based on a new in-house ASIC (400G Photonic Service Engine -PSE) chip capable of driving data rates up to 400Gbit/s. The 400G PSE is designed specifically for the ALU 1830 Photonic Service Switch [ALU 400G PSE]. The 1830 PSS 260CX2 card is a single-package concrete example of a rate-adaptive software configurable solution that provides 100Gbit/s with DP-QPSK, but can be upgraded to 200Gbit/s DP-16QAM. A single card can be deployed in either long-haul (100G mode) or metro/regional (200G mode) applications [ALU PR, 2015].

Coriant is introducing in the market flexrate interface modules for their hiT 7300 Multi-Haul Transport Platform [Coriant]. Equipped with two flexible physical interfaces, the line side module supports tunability between (1,2)x100Gbit/s DP-QPSK, 2x150Gbit/s DP-8QAM, and 2x200Gbit/s DP-16QAM for up to 400Gbit/s of line capacity, guaranteeing a dense granularity from 100Gb/s up to 400Gb/s. The flexi-rate modules are designed for super-channel applications with Nyquist pulse shaping and using proprietary algorithms to pre/post-compensate for several system impairments.

Cisco has developed a 200Gbit/s Multirate DWDM Line Card [Cisco] for the NCS 2000 System. The line interface supports various kinds of HD-FEC and SD-FEC and it can be software configured either as 50Gbit/s DP-BPSK, 100Gbit/s DP-QPSK or 200Gbit/s DP-16QAM, enabling a tradeoff between capacity and reach. Also, Cisco's Line Card supports up to 128 Nyquist shaped and 33-GHz spaced channels.

Ericsson is designing EONs to solve the issue of having separate IP and optical transport networks, causing unnecessary resource overhead. Relying on the latest advances for SDN approach both in the telecom and datacom industry, EON offers a solution to attain high levels of automation that modern networks demand for both IP and optical systems. The proposed solution is in support of operators moving toward a converged approach, with joint operation of IP and optical transport [Ericsson].

Finally, among all the vendors that are starting to provide solutions in the field of EONs, Infinera is the one which more deeply is embodying the essence of EON for their vision of convergent DWDM and OTN, where flexibility is realized as something unified from the client to the optical layer through the digital OTN and packet-agnostic cross-connect [Infinera-1]. The key elements of the Infinera transmission transport system are an in-house built PIC [Infinera-2] with a net total capacity of 500Gbit/s integrating all the analog processing for transmitting and receiving five modulated optical carriers, and an integrated DXC with a capacity from 2Tbit/s to 5Tbit/s per bay depending on the shelf size.

In particular, Infinera's XTC-4 with a switching capacity of 2Tbit/s and four universal slots for 500Gbit/s line or client interfaces, is, at present, and despite the limitation of the product, quite similar to an S-BVT-based device as identified within IDEALIST [Sambo-ComMag15] [Riccardi-EUCNC15]. However, limitations are present mainly in the optical flexibility and tuneability (all 5 channels are delivered as a whole and somewhat restricted in optical sub-bands) and power consumption; as a consequence of these limitations, also the optical add-drop capacity is constrained and efficient sliceability not effectively exploited.



2.2 Standardization activities

The most relevant ITU-T topic related to IDEALIST objectives is the evolution of OTN networks towards signals with bit rate beyond 100Gbit/s. The main driver regarding this topic is the corresponding evolution in standardization of Ethernet interfaces. Traffic analysis suggests that in a short time frame, new bitrates, other than the already standardized 1, 10, 40 and 100GbE, will be needed in Ethernet metro, regional and backbone networks, such as 25 and 400GbE. In fact, the IEEE is proceeding rapidly in the standardization of the 400GbE interface (400GbE task force has just been launched by IEEE802.3 in March 2014 for a standard approval expected by 2017), and has also started the activity for the definition of the 25GbE interface. Thus, also OTN must evolve in order to be able to transport these signals, guaranteeing more flexibility and the ability to scale to an increasingly higher transmission speed.

The present version of the OTN hierarchy does not support bit rates higher than 100Gbit/s (neither at the client side nor at the network side). Thus the standardization of 400GbE interfaces is bound to generate significant changes to the OTN hierarchy. On the network side, it will be necessary to increase the transmission capacity of the single channel, optimizing the usage of the optical spectrum; on the client multiplexing side, attention must be given to the choice of the time slot granularity of the electrical ODU matrix, in order to avoid bandwidth waste when transporting clients with bitrates much smaller than the network channel.

It is important to mention here that there is no activity so far with regards to the standardization of B100G (Beyond 100Gbit/s) optical interfaces, but the transport of such interfaces will be obviously undertaken by the adoption of the ITU-T G.694.1 flexgrid recommendation [ITU-T G.694.1], that enables a slot to be assigned to each channel, characterized by a central frequency and flexible bandwidth, supporting “super-channel” solutions.

On the electrical side, as already reported in the deliverable D2.2 [IDEALIST-D2.2], the definition of B100G line interfaces is based on OTUC_n entities ($n \geq 2$, where OTUC₂ means 200Gbit/s, OTUC₃ 300Gbit/s and so on). The most interesting news in last year's meetings has been the discussion on the time slot granularity of the ODUC_n/OPUC_n matrix, which has been chosen to be 5Gbit/s (although the mapping of ODU₀, ODU₁ and ODUFlex “below 100G” can be done in 5Gbit/s tributary time slots with a lower limit of 2 slots, so that the minimum size of a tributary in a ODUC_n matrix is still 10Gbit/s).

The choice of 5Gbit/s, instead of 10Gbit/s, was to enable a more efficient mapping of the future 25GbE client, and is not free of cost, as it requires a greater flexibility of the matrix. Nevertheless, it is considered a good choice, because, considering the traffic growth in metro-regional network, the introduction of 25GbE interfaces should be quite successful, as they seem to be a good compromise between 10GbE (which is not so efficient anymore) and 40GbE (which seems to be over-dimensioned for the metro segment and under-dimensioned for the core segment of the network). A first version of the relevant set of standards is under discussion and it is expected to be finalized by the first half of 2016.

In ITU-T there were also proposals for a “beyond-100G-OTUflex”, in order to accommodate optical interfaces with a capacity not multiple of 100G such as 150G, and with the aim of reducing the gap from the potential optical flexibility and the more rigid digital OTN. But a general agreement on this seems not to be gained yet (more details are reported in section 5.1).



Another topic of interest is the standardization of 100Gbit/s interfaces for DWDM networks, i.e. the revision of Rec. G.698.2 “Amplified multichannel dense wavelength division multiplexing applications with single channel optical interfaces” [ITU-T-G.698.2], which is relevant to small metro networks with amplifiers. The aim of the G.698.2 revision is the standardization of 100Gbit/s optical interfaces, covering distances between 200km and 450km, with a number of cascaded optical amplifiers (between 2 and 6) and no intermediate regeneration point.

The most important contributions from the suppliers relate to the definition of the standardization criteria, focusing in particular on the features of the transmitter. One fundamental criterion related to the quality of the transmitters is the parameter EVMHit_Ratio (Error Vector Magnitude Hit Ratio); thus a dedicated working session was used for the definition of a common test methodology to guarantee comparable results in the measurement of EVMHit_Ratio parameter on different supplier equipment.

Operators, on the other hand, though not directly involved in such detailed aspects of the standard definition, show a great interest in a rapid development of a black link application, which is one of the objectives of the new version of G.698.2, as it would lead to IP over DWDM multivendor applications with relevant CapEx savings. In fact some 100Gbit/s CFP or CFP2 interfaces are already available from different suppliers and show a very good compatibility. In addition, OIF is working in this direction.

Meanwhile OIF (Optical Internetworking Forum) has recently (July, 2015) uploaded on its website a very interesting white paper: “Technology Options for 400G Implementation”, which is a joint effort of different OIF working groups, namely Joint Carrier and Physical and Link Layer Working Groups [OIF-2015]. This document is particularly interesting for IDEALIST as it is discussing several options for 400Gbit/s implementations referring to a short-medium term time frame. In particular it includes a table (Table 1 of the document) reporting a list of solutions for 400Gbit/s first generation interfaces very similar to what we are proposing in this deliverable; interestingly enough the second segment of the document lists a number of different advanced options for more efficient implementations but not included in the quoted table; these may be implementations for successive generations.

The conclusions of the document [OIF-2015] are particularly enlightening and well in line with what have been independently concluded by IDEALIST (although IDEALIST has a larger perspective, not limited to 400G interfaces). We report it here, because this is a straightforward way to introduce, in the next section, the IDEALIST short and medium term vision:

“ Conclusion:

- Although some industrial systems begin to appear especially with 2x200G PDM-16QAM modulation format, 400G WDM technology is still in development.
- It has to be taken care to the risk to reproduce at 400G the “modulation format soup” which has “killed” 40G data-rate.
- Today, there is a need for 400G solutions to fully satisfy the requirements for LH or Metro applications in terms of:
 - o Transmission reach versus spectral efficiency.
 - o Flexgrid (ROADM cascade with 37.5 GHz / 75 GHz granularity).
- Hybrid Raman/EDFA amplification with improved noise figure could be the solution to the transmission reach/spectral efficiency trade-off.
- A new generation of ROADM able to manage really the 37.5 GHz



spectral granularity has to emerge to make the “flexibility” concept true.

- On the other hand, 400G client interface standardization is also far to be achieved and it is unclear today what technique will be chosen. ”

[OIF-2015, pag.16]



3 IDEALIST Vision for Data Plane Technologies

Given the experience acquired over the three years IDEALIST project, and the external context reported in chapter 2, the next five to six year time frame can be reasonably subdivided into two time ranges, indicatively from now up to 2017/18 and up to 2021, in which the availability and maturity of specific concrete technological solutions will enable a ready and effective introduction of the EON transport systems in European operator's networks.

With regards to these time ranges, the IDEALIST data plane technologies are identified as *short-term solutions* and *mid-term advanced solutions*. On the other hand, many other promising but more evolutionary studies will probably find a concrete application later in time, introducing more disruptive paradigms concerning, for example, node architectures. Collectively they are referred to as the IDEALIST *long term vision*.

In discussing the IDEALIST solutions and vision, the context scenario is that of a single administrative domain controlled by a single network operator, including both national networks (metro-regional and backbones) and international backbones. These networks are supposed to be almost transparent with very few regenerators and employing exclusively coherent technologies over uncompensated fibers [IDEALIST D2.1].

The main clients of these new optical networks will, almost certainly be based on IP or Ethernet technologies; however a client-agnostic transmission technology is advisable to also handle the possible smaller presence of legacy and Other Licensed Operator (OLO) client traffic: digital wrapping and packet/OTN switching fabrics are probably the best technological choice. Furthermore the near future availability of 400 GbE interfaces on routers is pushing towards the introduction of 400G-and-beyond transponders/line interfaces and more flexible solutions in the network.

In any case, the interoperability between different network segments will almost certainly be at OTN electrical level in the short term (2017/18) scenario, as the standardization won't be complete for a black link interoperability model. Even flexible colored optical line interfaces (i.e. BVTs) equipped directly in routers for transport in DWDM EON systems, despite being an interesting potentially low-cost alternative to the interposition of transponders, require an improvement in interoperability standards. Nevertheless, agreements between different suppliers will enable the implementation of the "alien lambda" solution, but always within a single operator domain. Pure black link solutions will be probably available in the medium term scenario (2021), or even in the "long term vision".

In the short term horizon, the EON full capabilities are not expected to be completely employed, for both lack of technological and standardization maturity. Moreover, traffic grow rate and dynamicity seem to be lower with respect to the expectations of few years ago. However, the flexible use of the optical spectrum and the potential OpEx saving due to the reduction in the number of items and stock with the introduction of (S)-BVTs and related SDN functionalities, are opportunities that will be certainly exploited in the medium term and will continue in the long term.

Accordingly, next few years will see the rise of optical networks based on EON, with flexgrid ROADM and BVTs mainly in the backbones or in most demanding metro-area scenarios. The ROADM architecture will not fundamentally deviate from the traditional broadcast and select or switch and select, with CDC modular Add&Drop functionalities.



BV-WSS with LCoS technology will enable flexgrid, offering full backwards compatibility with both the standard 100GHz and 50GHz ITU grids. CDC Add&Drop functionality will be probably designed to match S-BVTs capabilities in term of number of carriers, looking for a trade-off between cost and performance.

Within this short term horizon, the EON data plane will see the introduction of line interfaces with software configurable rates ranging from 100Gbit/s to 400Gbit/s, in some cases with sliceable solutions. The flexibility will rely on the modulation format (ranging from DP-BPSK to DP-16QAM) with 100G granularity, FEC options and the number of sub-carriers composing the super-channels. Among innovative transmission techniques for super-channel generation, Nyquist WDM will be the first to be employed. After the consolidation of this “first generation” of EON products, non-disruptive changes are expected as technology progresses smoothly (higher rates, enhanced flexibility) as well as the traffic growth.

In 2021 and longer term horizon, sustainable capacity upgrade will be made possible by technological enhancement in footprint and power consumption: more capacity will be available on the same shelf. For example CMOS for electronic application is expected to downsize from today 40 nm gate size to 28 and then to 14 nm in the medium term while photonics devices could evolve from today’s hybrid photonics to CMOS silicon photonics starting from 130 nm gate size and going to 90 nm and 60 nm. For the aforementioned reasons, cost and power effective 1Tbit/s and sliceable BVTs will be introduced in the medium term (2021) even if some specific implementation may be introduced to the market in a shorter time frame.

In term of functionalities and optical performance, the “second generation” (S)-BVT (2021) will implement new and more efficient ASICs with enhanced DSP functionalities for both flexibility (for example 25G instead of 100G steps in transmission capacity; hybrid modulation formats, etc.), and performance (non-linear impairment mitigation, next generation FEC, etc.). The introduction of new interfaces based on TFP is also expected for specific demanding long distance and spectrally efficiency needs, though the market will still be almost certainly dominated by Nyquist WDM super-channels.

Within the today-to-2021 time range, OFDM technology will be mature and line interfaces based on this transmission technique will possibly find employment in specific metro and metro-core scenarios.

For what concerns the control plane and monitoring, in the today-to-2018 time frame, the control plane/monitoring are likely to be based on the standard IETF solution supported by IDEALIST [IDEALIST-D3.3]. In the 2021 and longer term scenarios it will be probably based on ABNO.

Considering the optical network element’s design, an effective technological breakthrough will take place only when the traditional node architecture will be no longer able to support the traffic increase: BV-WSS have a limited number of optical ports (actually no more than 20) and thus cannot support more than a maximum number of DWDM transmission links at the same time. In addition, hard-wired node technologies will impede the reconfigurability and programmability required to adapt dynamically to unpredictable future network traffic demands. If this limit is exceeded, innovative node architectures have to replace the conventional ROADM architecture. IDEALIST in the long term vision has found an interesting candidate in the flexible Architecture on Demand (AoD) paradigm. Within this node framework, advanced techniques (possibly all optical) for traffic engineering, defragmentation and super-channel regeneration will find a place as specific functional modules to be added when and where they are necessary.



4 Data plane solution for short and mid term

4.1 Node capacity, reach and flexibility

In order to define a reasonable figure for the capacity and size of an EON node for the IDEALIST short term solution (2017/18), the node specifications already elaborated in the early stage of the project, and collected in Table 2.6 of deliverable D2.1 [IDEALIST D2.1], can be used as a starting point.

Here, these figures are reported, with some amendment, in Table 1 for the clarity of presentation. Data were obtained from an optimistic extrapolation of the actual (2013) traffic of three optical backbone networks of European operators giving an average extrapolated capacity and size for the biggest nodes in each network.

The original D2.1 table reports also figures extrapolated to 2025, which seem, now, slightly overestimated, while 2018 figures can now be considered reasonably as the target maximum capacity of a node ready for the market, dimensioned with sufficient margin to allow the handling of possible unexpected traffic increases. This does not mean that all this capacity is required in the network from the first installation, but that the availability of commercial transmission systems of such a capacity should guarantee a reasonable long life for the deployed network.

Table 1: 2018 expected node requirements, amended from Table 2.6 of deliverable D2.1.

	2018
Max optical switching capacity	60 Tbit/s
Max electrical switching capacity	18 Tbit/s
Type and number of client interface (typical node)	10G-100G-400G, IEEE 803.1/3, number: 150
Number of fibers attached to the node	About 4. 6 where ND is 6
Minimum super-channel rate	10 Gbit/s
Maximum super-channel rate	400Gbit/s-1 Tbit/s
Typical super-channel rate	100 Gbit/s-400Gbit/s
Minimum transparency reach	700 km
Typical switching time	10 s (restoration), 50 ms (protection)

Some remarks are necessary concerning mainly the type of client and line interfaces: during the lifetime of the system it is expected that 400GbE will become a relevant client (starting approximately in 2018), before the introduction of 1Tbit/s. Consequently the typical super-channel rate, 100Gbit/s in 2018, may in a short time become 400Gbit/s, and later 1Tbit/s. Thus the IDEALIST short term solution should consider 100Gbit/s, 200Gbit/s and 400Gbit/s as total capacities of super-channels. As already stated in D2.1, 10Gbit/s clients will be groomed into 100Gbit/s or larger channels, leaving room for 10Gbit/s line interfaces only in the metro area.

Considering the node architecture, it is confirmed that a conventional broadcast and select or switch and select architecture, with up to 20 total optical ports, should be adequate to handle the maximum number of fibers attached to the node reported in Table 1 (the

topological nodal degree, ND, maybe lower). Even a three-fold traffic increase, thus approximately requiring 3 times the number of fibers attached to the node, should be within the maximum number of lines supported by ROADMs based on actual 20 ports BV-WSSs.

In Table 1 a reference transparent reach of 700km is reported and refers to a typical working path in a national European backbone network (protection paths may sometimes double this figure). Obviously, for Pan-European networks and metro-core areas the same figures should be respectively up-scaled and down-scaled. This broad range of distances (sometimes coexisting in the same network: the reported figure is only an average but the variance may be quite huge) can't be handled in a spectral efficient way with a single modulation format. Thus in the system vendor portfolio, interfaces with several modulation format capabilities should be present, even better if software configurable. This is one of the main drivers for the introduction of configurable BVTs and possibly S-BVTs.

4.2 Optical ROADM architecture

As already mentioned in chapter 3, in the short and medium term time frame, the ROADM architecture is not expected to deviate from the traditional broadcast-and-select or switch-and-select ROADMs, with CDC modular Add&Drop functionalities.

Anyway, if (S)-BVTs with the capability of several carriers each (4 or more) will be widespread employed in a network, a possible matching between CDC Add&Drop functionality of ROADM nodes and (S)-BVTs optical capacity is to be envisioned, looking for a trade-off between costs and performance. Two main architectures can be identified.

The first and simplest Add&Drop ROADM architecture is shown in Figure 1. At the transmitter side, the sub-carriers generated by a single S-BVT are coupled and then are split towards each line output port of the node in a broadcast fashion. The Line Side (ports that connect the traffic coming from other nodes to the ROADM) is based on BV-WSSs. Depending on the BV-WSSs configuration, sub-carriers generated by the same S-BVT may be independently directed toward different output ports, thus following different paths. Otherwise, these sub-carriers can create a super-channel and be directed to the same port/destination. At the receiver side, multiple sub-carriers can be detected by the same S-BVT, which is connected to an input port through the coupler. Then, sub-carriers are split to be detected by a specific receiver into the S-BVT.

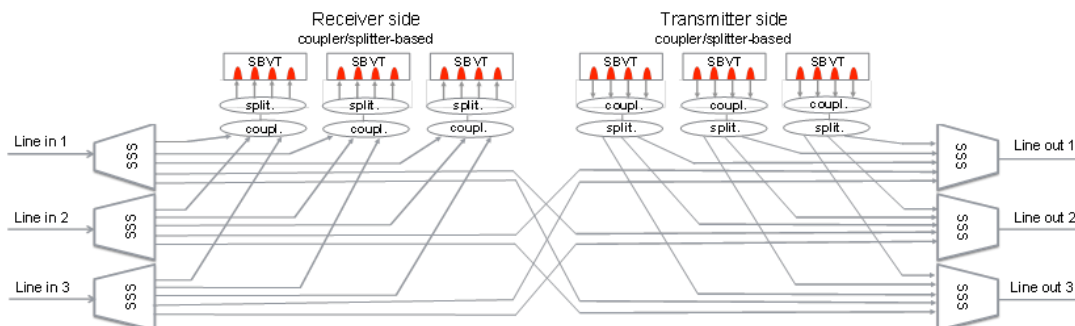

Figure 1: ROADM with Add&Drop modules based on coupler and splitter.

Considering 1x20 and 20x1 BV-WSSs and a nodal degree of 5, each BV-WSS can host up to 16 S-BVTs (at the transmitter and at the receiver sides) that are shared per direction,

this independently of the number S of S-BVT carriers. The Add&Drop module based on coupler and splitter is usually inexpensive, however, this module introduces a constraint into the Routing and Spectrum Allocation (RSA): sub-carriers generated (or detected) by the same S-BVT cannot use the same portion of the spectrum because coupler/splitter pairs are connected by a single fiber where sub-carriers share the spectrum. Thus, coupler/splitter-based Add&Drop is not spectrum contentionless.

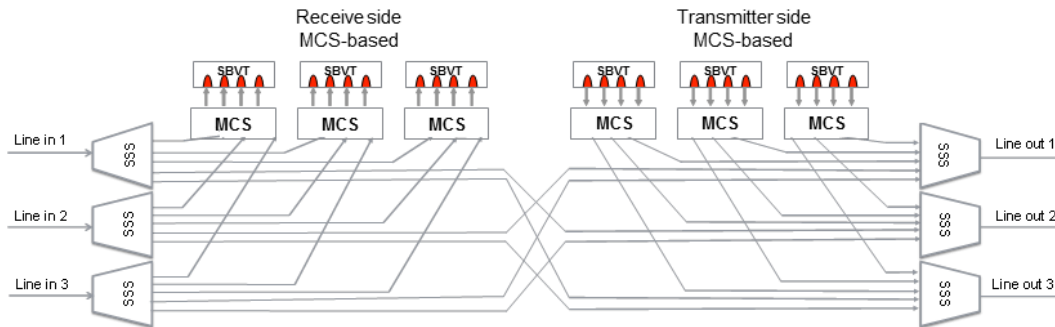

Figure 2: ROADM with Add&Drop modules based on multicast switches.

The second architecture is based on the MultiCast Switches (MCS) and shown in Figure 2. The MCS architecture is composed of switches and couplers. Such architecture is contentionless since sub-carriers generated (or detected) by the same S-BVT may use the same portion of spectrum provided that they are directed to (or come from) different line ports. On the other hand, this is surely a more expensive solution with respect to the first one.

In [Dallaglio-ECOC15] the performance achievable with the two different architectures has been investigated by means of simulation activities, evaluating the impact of the contentionless property on blocking probability in case of low granularity (100Gbit/s) and high granularity (1Tbit/s) traffic. Based on the simulation results, MCS architecture achieves better performance than splitter/coupler in case of low granularity traffic. Splitter/coupler achieves similar performance to MCS with 1Tbit/s traffic, suggesting that, in case of requiring a fast network migration towards high bit rates, splitter/coupler-based Add&Drop modules may be an effective and cheap solution.

Coming back to the architecture of a ROADM, in a longer term perspective, both conventional approaches are bound to show their limitation regarding the ability to adequately scale with the increase of traffic and the number of DWDM lines contending on each node. At this time, a different approach such as the Architecture-on-Demand (AoD) node [Hugues-Salas-ComMag15] will be able to overcome these limitations, as described in chapter 6.

To conclude this section it should be remembered the claim for the need of a new generation of ROADM able to manage really the 37.5GHz spectral granularity, or in other terms, with BV-WSSs able to synthesize optical filters with steeper spectral edges. This requirement is essential to reduce filtering penalties on long optical paths, but seems unlikely to be fulfilled in the near future without compromising on device footprint and cost.



4.3 Flexible transponders: (S)-BVT

This section presents a possible list of short term (S)-BVT modules, together with a brief description of some innovative functionalities and transmission techniques that will be part of a “second generation” of S-BVT cards looking at a medium term time frame. All the proposed solutions follow the general (S)-BVT architecture described in great details in previous deliverables [IDEALIST D2.1] [IDEALIST-D2.2] and in [Riccardi-EUCNC15] [Sambo-ComMag15].

More specifically, short term solutions are designed to enable a “first generation” deployment of EON networks, delivering super-channel with a capacity of up to 400Gbit/s, with flexibility in modulation and rate, and with the optional possibility of sliceability. Currently, Nyquist WDM (NWDW) has been introduced on the market by several vendors and others will follow soon.

As part of the “second generation” of BVTs, thanks to improvements in digital and optical integration, in component quality and in ASIC capabilities, enhanced functionalities will be added without compromising cost and power consumption.

This innovation will positively affect all transmission techniques investigated within IDEALIST, though we believe that NWDW is the one that will mostly benefit from those advances. Concerning, the Orthogonal Frequency Division Multiplexing (OFDM) and Time-Frequency Packing (TFP), their applications, as part of the second generation of BVT, will depend on particular scenarios and conditions. For example, OFDM might find to be useful in the context of metro applications, while TFP for larger networks. It is worth mentioning that in both cases this could be overruled by NWDW.

The need for higher capacity super-channels, together with the foreseen 1TbE standardization, will be the driver for the introduction of 1Tbit/s or even greater capacity S-BVTs with modular architecture, in which full functionalities of EON both in the digital and optical domain will be implemented.

Another topic of particular relevance within the data plane in IDEALIST is the interoperability between/among vendors. IDEALIST investigated this topic, also together with WP1 and WP3 achieving important results that have been published as invited papers in the leading conferences and magazines. Overall, we showed that the interoperability can be guaranteed, under certain conditions, and that distances below 300km can be assured between different vendors with the current FEC standard. Clearly, further standardization in FEC will positively affect the functionality of elastic optical networks.

4.3.1 (S)-BVT: 2017/18 perspective

In Table 2 a list of (S)-BVT modules is reported. They represent a selection of modules that are supposed to be the most relevant from the today-to-2018 time-frame perspective, both for the technological maturity and the expected deployment of new optical flexible networks [IDEALIST- D6.4].

The four selected modules are:

- A fixed (meaning not bandwidth variable) 100Gbit/s single carrier DP-QPSK module for metro-regional and long haul applications (F_100G_1L).
- A software bandwidth configurable 100-200Gbit/s single carrier DP-QPSK/16QAM module for metro-regional and long haul applications (BV_200G_1L).



- A software bandwidth configurable module with net capacity from 100Gbit/s to 400Gbit/s in steps of 100Gbit/s; up to four sub-carriers DP-BPSK/QPSK for metro-regional, long haul and ultra-long haul applications. Sliceability is optional in this module ((S)BV_400G_4L).
- A software bandwidth configurable module with net capacity from 100Gbit/s to 400Gbit/s in steps of 100Gbit/s; up to two sub-carriers DP-BPSK/QPSK/16QAM for metro-regional, long haul and ultra-long haul applications. Sliceability is optional in this module ((S)BV_400G_2L).

Table 2: List of relevant 2018 (S)-BVT modules and possible operational modes achieved varying the modulation format and the number of subcarriers.

Module name	Net Capacity (Gbit/s)	Modulation Format	Sub-carries	Net GBaud	Gross GBaud (30%)	Clear Spectral width (GHz)	Target OSNR (dB)	Reach (Km)	Application
F_100G_1L	100	DP-QPSK	1	25	32.5	34.5	11.5	2400	R-LH
BV_200G_1L	100	DP-QPSK	1	25	32.5	34.5	11.5	2400	R-LH
	200	DP-16QAM	1	25	32.5	34.5	20.0	360	
(S)BV_400G_4L	100	DP-BPSK	2	25	32.5	69	8.5	4800	R-LH-ULH
	200	DP-BPSK	4	25	32.5	138	8.5	4800	
	100	DP-QPSK	1	25	32.5	34.5	11.5	2400	
	200	DP-QPSK	2	25	32.5	69	11.5	2400	
	300	DP-QPSK	3	25	32.5	103.5	11.5	2400	
	400	DP-QPSK	4	25	32.5	138	11.5	2400	
(S)BV_400G_2L	100	DP-BPSK	2	25	32.5	69	8.5	4800	R-LH-ULH
	100	DP-QPSK	1	25	32.5	34.5	11.5	2400	
	200	DP-16QAM	1	25	32.5	34.5	20.0	360	
	200	DP-QPSK	2	25	32.5	69	11.5	2400	
	300	DP-8QAM	2	25	32.5	69	17.2	850	
	400	DP-16QAM	2	25	32.5	69	20.0	360	

First of all it should be noted that some of the modules of Table 2 are already commercially available in 2015, including F_100G_1L and BV_200G.

In Table 2, for all modules and operational modes, the gross baud rate is calculated using a ~30% overhead for enhanced SD-FEC housing. The clear spectral occupancy is estimated from a Nyquist spectral shaping with a roll-off of 10% and a laser wavelength stability of ± 1 GHz. The actual number of ITU-T G.694.1 slots needed for transmission has to guarantee a spectral width larger than these figures with an additional margin depending on the number of crossed filters in the path along the network.

Many studies have shown that the penalty due to cumulative filtering on a single carrier 32.5Gbaud Nyquist shaped channel, with filter bandwidth of 37.5GHz, can become unacceptable after very few filters (less the 10) [Morea-JOCN15]. Thus, considering that in a single hop path the number of filters affecting the channel is 4 in case of a broadcast and select, and 6 in case of a switch and select ROADM architecture (including conventional



Add&Drop), and that in a multi-hop path this number is increased by 1 or 2 for each ROADM crossed, it is clear that, to deliver this channel within a 37.5GHz slot, a trade-off between penalties from reach and filtering effects, has to be carefully considered. This seems to suggest that the smallest usable spectrum slot is 50GHz, but this conclusion has not to be regarded as definitive, since, in some cases, the problem can be mitigated or even overcome using lower overhead for FEC (HD-FEC) or lower symbol rates together with higher modulation formats. Moreover in a mid-term perspective, advanced techniques to counteract filtering penalties will become available (see section 4.4.1.3 and [IDEALIST-D2.3] for a detailed discussion of the problem and of the possible solutions).

On the other hand, flexgrid technology enables the improvement of spectrum efficiency when multicarrier super-channels are taken into account, as only the two outer-most sub-carriers are affected by cumulative filtering, which affects them only on one side, resulting in a lower penalty with respect to the single-carrier channel.

So, for example, a two sub-carrier super-channel with baud-rate of 32.5Gbaud, and with a clear spectral width of 69GHz is likely to be delivered in most cases within a 75GHz slot, and analogously, a four sub-carrier super-channel with a clear spectral width of 138GHz is likely to be delivered within a 150GHz slot.

Returning to Table 2, Target OSNR and reference distance are rough estimations; the exact values depend on specific technological implementation and employed FEC. Also a margin is included to account for component ageing, system and cable margin, amplification strategy and fiber type and non-linear impairment evaluation.

More specifically the reported target distance is obtained in the hypothesis of G.652 conventional fibers, 90km spans with 25dB attenuation (including margin); EDFAs with NF of 6dB with no Raman amplification; a modulation format specific implementation penalty, and using a worst case GN-model evaluation of the non-linear interaction. Reach is calculated for the optimal per channel output power. Obviously greater reaches are obtained, without compromising margins, if shorter reference links are considered.

These choices and the consequent estimated reaches and OSNR values appear far from published experiments and laboratory records, but they nevertheless represent an indication of what realistic commercial products and terrestrial fiber plants can achieve. Finally, specific modules and transmission system implementations and the adoption of non-linear mitigation techniques jointly to hybrid amplification could certainly lead to better performance. This is valid also for the case of newly deployed links (with new optical cables) that will bring a significant benefit to the overall performance.

The aspects related to power consumption, modularity, size and supported client signals, depend on the specific vendor implementation, and consequently are not reported here.

4.3.2 Advanced solutions: 2021 and beyond perspectives

In the following the most relevant medium term expected innovations are briefly described referring, for all the details of the techniques, to other IDEALIST WP2 deliverables [IDEALIST-D2.1] [IDEALIST-D2.2] [IDEALIST-D2.3] and the references therein.

The 2017/18 perspective, discussed above, summarizes three main transponder variants that will offer the most important aspects to reduce cost per bit. In particular dealing with power consumption, modularity, size and supported client interfaces for optical flexible networks. Going forward to 2021, the main output shifts towards the 1Tbit/s interface. Following in this direction, it is expected that 1.6Tbit/s interfaces are likely to evolve to support several 400Gbit/s client interfaces. Several paths can be foreseen to enable



≥ 1 Tbit/s net capacity and among them: (I) By evolution towards higher order QAM formats (e.g. 64QAM, 128QAM) and novel four dimensional constellations where power efficiency (in terms of spectral efficiency vs. sensitivity penalty) can enable longer reach; (II) Multiple Carrier based on NWDM, TFP and OFDM.

Focusing on (I), next generation coherent transponders are expected to offer 1Tbit/s super-channels by employing a small number of sub-carriers, to keep the costs as low as possible. This pushes the emphasis on higher order modulation formats at higher symbol rates. As current 100Gbit/s transponders rely on symbol rates around 30 – 32Gbaud, higher symbol rates (≥ 40 Gbaud) will be required to trade-off the number of subcarriers per super-channel. Employing higher symbol rates [Raybon-JLT14] reduces the number of deployed optical components, although the feasibility of electronic multiplexing rates and the likely performance of CMOS DAC/ADCs and the required compensation of modulators, drivers and photo-receivers become quite critical due to the bandwidth limitation of these components. Recently, high symbol rates of the order of 80Gbaud [Raybon-IPC12], 107Gbaud and 128Gbaud [Raybon-ECOC13] have been demonstrated over transmission distances approaching 2000km employing modulation formats DP-QPSK and DP-16QAM. For higher baud rate systems such as these, the design of soft-decision FEC codes is critical.

In IDEALIST, the focus is primarily in increasing the modulation order to DP-64QAM. Recent studies conducted by T.Rahman et al. [Rahman-ECOC15] have shown that 1000km is within reach for DP-64QAM super-channels. Issues such as noise become less critical to the performance of these signals, however, optical fiber non-linear effects requires a careful link engineering exploiting hybrid amplification schemes. Several scenarios have been studied in a recent field trial over 762km of field installed G.652 fibers showing 4 super-channels at data-rates ≥ 1 Tbit/s requiring similar baud-rates (34Gbaud) as 100Gbit/s transponders (4×300 Gbit/s = 1.2Tbit/s at 34Gbaud).

For 2021, the evolution and standard application of DP-128QAM is foreseen. Although the increase in bit-rate can be linear with respect to symbol rate, the increase in bit-rate is only logarithmic with respect to the constellation size particularly as the effective DAC resolution is limited. Nevertheless, DP-128QAM will enable per super-channel rates > 2 Tbit/s.

4.3.2.1 S-BVT based on Nyquist WDM

The bandwidth variable transponder is literally a means to adapt the delivered bit rate thanks to a variation of the symbol rate. Tuning the symbol rate results in a two-fold benefit: (I) the occupied spectrum is directly proportional to the symbol rate, hence by allocating “just-enough” spectrum to satisfy the traffic demand results in spectrum savings; (II) in addition, tuning the symbol rate may offer an energy reduction when the BVT is implemented with a variable frequency clock. The energy consumption indeed scales with the frequency clock either linearly or even exponentially if dynamic frequency and voltage scaling (DVFS) is applied. With regards to the transmission, at optimized power, the optical reach is found to be weakly dependent to the symbol rate [Poggiolini-PTL11-2]. Therefore it is not possible to trade distance with data rate with a variable symbol rate transponder. The degree of freedom of tuning modulation formats will be needed as well.

Today, as underlined in section 2, multi-rate transponders are already commercially available with a wide range of modulation formats leading to only one transponder type for a few rates such as 100Gbit/s, 200Gbit/s and 400Gbit/s. To fully leverage flexgrid ROADMs, it is thus expected that the longer term solutions will include various symbol rates in addition to an even wider range of modulation formats. Typical data rates would be



100Gbit/s, 200Gbit/s, 300Gbit/s, 400Gbit/s up to 1Tbit/s. Several 400Gbit/s [Rahman-ECOC14] and 1Tbit/s record experiments were conducted during the project lifetime [Renaudier-ECOC13] [Mardoyan-OFC15] [Rahman-JLT15] [Rahman-ECOC15] testing different techniques of transmission. Spectrally-efficient super-channels for 1Tbit/s transmission will most likely be the next step for a 1Tbit/s product whereas single-carrier 1Tbit/s represents a yet longer term approach that is highly dependent on the quality and bandwidth of optical and even more electrical components.

In addition, nonlinear mitigation techniques are now of high interest by the research community and it would most likely be one of the key features to exhibit in a long term solution if telecom operators are willing to go in this direction as well. A nonlinear compensation technique for cross-channel effects was received good feedback by the research community [Layec-ECOC14] since this technique provides 0.7dB gain for DP-QPSK signals.

On the other hand it was showed in [Napoli-JLT14] that the widely studied digital back-propagation could be actually implemented, with a similar complexity to the one of the current frequency domain equalizer, for applications such as dispersion managed optical systems. Complexity being the major limitation of existing nonlinear mitigation techniques, newer methods are being investigated. In this context, the concept of digital subcarrier multiplexing has recently gained significant interest. Employing several low symbol rate Nyquist filtered channels instead of a single high symbol-rate channel, has been shown to possess non-linear tolerance and enable extension in reach both in single channel and WDM scenarios [Nespola-OFC15]. Hence, this technique could be a promising candidate for future BVT.

4.3.2.2 S-BVT based on Time Frequency Packing (TFP)

A different S-BVT transmission technique has been also proposed based on DP-QPSK modulation format conforming to the general IDEALIST S-BVT architecture presented in [Riccardi-EUCNC15] [Sambo-ComMag15].

TFP is able to achieve reach adaptation by tuning the code [Sambo-OFC15]. Because of the use of DP-QPSK format only, DAC may be avoided. TFP consists of sending pulses that strongly overlap in time or frequency or both, to maximize spectral efficiency, while introducing inter-symbol (ISI) and/or inter-carrier interference (ICI) [Secondini-JLT15] [Sambo-JLT14] [Sambo-JOCN14]. Coding and detection are properly designed to account for this operation.

A Low-Density Parity-Check (LDPC) code can be used to approach the maximum information rate achievable with the given modulation (typically DP-QPSK), accounting for the presence of noise, ISI, ICI, etc. Code rate, thus spectrum efficiency, may vary with the OSNR of the sub-carrier (the lower the OSNR, the larger the redundancy).

The receiver of each sub-carrier exploits coherent detection with DSP. In particular, a two dimensional adaptive feed-forward equalizer recovers the signal, compensating for linear propagation impairments (e.g., dispersion) and implementing electronic filtering. Given the introduced ISI, TFP requires a receiver based on sequence detection, such as the well-known Bahl-Cocke-Jelinek-Raviv (BCJR) detector [Bahl-TRANSINFO74], which exchanges information with an LDPC decoder.

TFP provides high spectral efficiency (e.g., 6.4bit/s/Hz with the low-order DP-QPSK [Sambo-OFC15]) and flexibility because the required all-optical reach can be achieved



through the selection of proper code rate even without requiring the support of multiple modulation formats.

Such transponder also enables code adaptation to react to data plane hardware degradations (e.g., optical amplifier) as will be explained in Sec. 6.4.

4.3.2.3 S-BVT based on Orthogonal Frequency Division Multiplexing (OFDM)

This S-BVT is proposed with two different implementations, either using cost-effective direct detection or coherent detection to address different application scenarios.

Optical OFDM consists in the transmission of multiple orthogonal sub-carriers, each running at low symbol rate. These sub-carriers are generated at the DSP of the transmitter and converted into the analog electrical domain by an ADC. Afterwards, the resulting electrical signals are optically modulated by an optoelectronic front-end, which can be an external modulator excited by the appropriate lightwave source. At the receiver, either a direct-detection or a coherent receiver front-end can be used for converting optical signals into the electrical domain, prior to digitization and further DSP demodulation/equalization at the receiver.

Since the OFDM sub-carriers are generated in the digital/electrical domain, a fine granularity and narrow sub-carrier spacing can be achieved, usually of the order of hundreds or even tens of MHz. Also, a set of transmission system parameters required for channel estimation/equalization are inherently acquired thanks to the insertion of training sequences, cyclic prefix and pilot tones. This information is exploited at the DSP of the receiver to mitigate and equalize channel impairments, usually employing a single-tap zero-forcing equalizer.

Thus, OFDM provides advanced spectrum manipulation capabilities, including arbitrary sub-carrier suppression and bit/power loading, as reported in [IDEALIST-D2.3]. Thanks to these features, OFDM transceivers can be ad hoc configured for achieving a certain reach and/or coping with a targeted data rate, making OFDM suitable for the so-called elastic optical networks [Casellas-JSAC13].

4.4 Control and Monitoring

4.4.1 Control

This section discusses the control of S-BVTs at source and destination nodes and of BV-WSS synthesized optical filters performing switching at intermediate nodes. Work has been done in conjunction with WP3, where proper protocol extensions and controller architectures have been proposed and implemented to remotely set transponders and ROADM nodes. Relevant physical layer parameters have been identified for the control of the IDEALIST data plane.

4.4.1.1 Main transmission parameters for control

Information on transmission parameters has to be managed by the control plane, i.e. stored in databases and exchanged through properly designed protocols (e.g., with extended OpenFlow messages, see WP3).



First of all, a centralized controller (e.g., ABNO architecture) has to know about the capabilities of the data plane: e.g., the bit rate supported by a transponder. Then, transmission parameters have to be computed based on the requested service. As an example, based on the requested information rate between a source-destination pair, a proper FEC and modulation format to guarantee error-free transmission along a path connecting the source with the destination have to be selected. To this purpose, the control plane will perform a discovery phase to learn the capabilities and the characteristics of the data plane. Then, based on the request, the control plan will properly configure / set / program the hardware to satisfy requested services.

In Table 3 the main physical layer parameters are summarized. Proper protocol extensions including such parameters have been proposed within WP3 [IDEALIST-D3.2].

Table 3: Transmission parameters to control.

Bit rate	A range of bit rates may be supported by a transponder, e.g. 100-400Gbit/s.
Modulation format per sub-carrier	Multiple types of modulation formats may be supported, such as DP-BPSK, DP-QPSK, DP-8QAM, DP-16QAM. Specific aspects like single/dual polarization to be considered and specified for a correct detection of the transmitted signal.
Baud rate	The transponder needs to be equipped with electronic processing capabilities supporting a specific baud rate. Typical values for a 100Gbit/s transmission include 27.952 Gbaud or 31.241 Gbaud, accounting for either 7% or 20% overhead for forward error correction (FEC), respectively.
Sampling rate and analog bandwidth	Minimum hardware requirements in terms of sampling rate, ADC resolution and analog bandwidth have to be guaranteed. An example of minimum sample rate for a 100Gbit/s DP-QPSK communication is 28GS/s with 6 bit ADC resolution and 15GHz analog bandwidth.
FEC/Coding type	Hard decision (HD)-FEC has been standardized [ITU-T-G.709]. It is expected that future standardization panels will consider soft decision (SD)-FEC as well. Moreover, Low Density Parity Check (LDPC) coding may be also considered, being used by TFP.
Power	The range of output power values at the transmitter (launch power) and receiver (maximum values of the overall and per-channel received optical power, and input power sensitivity) have to be known.
Frequency slot	The portion of the spectrum where a media channel is switched. It is defined by a central frequency and a slot width. Central frequency: $193.1 \text{ THz} + n \times 0.00625 \text{ THz}$, with n an integer. Slot width: $m \times 12.5 \text{ GHz}$, with m an integer.
Number of sub-carriers	The number of supported sub-carriers has to be specified (e.g., eight subcarriers in the case of a 1Tbit/s communication). Optional capabilities may be considered, such as the possibility to activate just a subset of those available subcarriers.
Sub-carrier spacing	The spectral distance between sub-carriers composing a super-channel. This may not follow the ITU-T flexgrid standard.
Number of digital sub-carriers	The number of digital/electrical sub-carriers per optical sub-carrier in case of employing multicarrier modulation techniques (e.g. OFDM).
Optical sliceability	The support of sliceability into a transponder.



Finally, the ITU has provided a list of optical parameters to be considered, mainly focusing on linear impairments. In particular, the G.698.2 [ITU-T-G.698.2] provides optical parameter values for physical layer interfaces of WDM systems mainly intended for metro applications encompassing optical amplifiers and filter functionalities. This recommendation currently focuses on bit rates at 2.5 and 10Gbit/s.

4.4.1.2 Control of a S-BVT

This section discusses the programmability of a generic S-BVT following the architecture specified in [Riccardi-EUCNC15] [Sambo-ComMag15], with particular reference to the modules / devices that have to be controlled in order to set specific transmission characteristics. Indeed, an S-BVT finds application whenever transmission characteristics can be set based on the actual traffic demands: by expanding or contracting the bandwidth of an optical path (e.g. varying the number of sub-carriers), by adapting the optical reach, and by directing the generated super-channels toward specific destinations. To achieve these functionalities, several sub-carriers can be connected or disconnected and the modulation format or code-rate can be modified based on the required optical reach. The following S-BVT transmission characteristics are considered with reference to the general S-BVT architecture agreed among IDEALIST partners [Riccardi-EUCNC15] [Sambo-ComMag15] [IDEALIST-D2.2]:

- Association of an OTN stream with a specific sub-carrier.
- Line rate (e.g., number of sub-carriers).
- Optical reach adaptation.
- Modulation format.
- Code rate.
- Optical carrier frequency.
- Specific functionalities at the DSP (e.g., equalization).

OTN streams have to be associated with a media channel which is directed to a specific destination. The media channel is loaded with several sub-carriers. The association of OTN streams with a set of optical sub-carriers is obtained by an electronic switch implementing the Flow Distributor (see [IDEALIST-D2.2]), enabling a remote control of its cross-connections.

Line rate can be set by activating, or not, a set of sub-carriers. Optical reach adaptation can be obtained by relying on a proper modulation format. For example, by controlling the DAC into the transponder, it is possible to set the modulation format: e.g., multi-level data from the DAC is used to achieve a DP-16QAM while single-level data is used for a DP-QPSK. Optical reach adaptation can be achieved also with code adaptation as in [Sambo-JLT14]. The code rate can be electronically programmed via software by the encoder. Optical carrier frequency can be set by configuring the array of lasers or a multi-Wavelengths (MW) source generating the sub-carriers. Specific functionalities at the DSP can be configured via software (e.g., pulse shape, filtering).

4.4.1.3 Optical switching control

In general, the control of ingress, transit and egress nodes requires the configuration of the optical output ports and the related filters' passband. This is achieved by setting the proper

effective frequency slot [ITU-T-G.694.1] along the path. The frequency slot is defined as the frequency range allocated for a connection, within the flexible grid and unavailable to other slots [ITU-T-G.694.1]. A frequency slot is identified by its nominal central frequency and its slot width. The nominal central frequency f of a frequency slot is identified by the parameter n , such that $f = 193.1 \text{ THz} + n \times 0.00625 \text{ THz}$, where n is a positive or negative integer including 0. The slot width (equal or higher than the required bandwidth) indicates the amount of reserved optical spectrum and it is defined to be $m \times 12.5 \text{ GHz}$, where m is an integer greater than or equal to 1.

The frequency slot of a lightpath has to be computed according to transmission parameters (e.g., number of sub-carriers) and the expected quality of transmission (QoT), which should also account for filtering effects in the nodes [Poole-OFC11] (e.g., through an OSNR penalty [Kozicki-OptE10]). Indeed, filters present a non-ideal rectangular behavior, with non-negligible transition bands that may introduce distortions on the transmitted signal. So far, the frequency slot is configured by assigning a unique couple $(n; m)$ along the entire connection, i.e. the same bandwidth is configured in all the traversed filters. Figure 3 illustrates an example of a transmission through a cascade of three nodes. First, it is assumed that $m=4$ is assigned to the connection (Figure 3(a)). It is also assumed that after the first and second node, acceptable QoT is experienced. However, after the third node, excessive detrimental filtering effects are experienced, preventing the actual setup along the three nodes with $m=4$. Thus, larger bandwidth should be computed and configured in order to operate filtering in a flatter region (i.e., avoiding the filter transition bands), thus limiting filtering effects. Figure 3(b) shows the frequency slot configured, in all the three nodes, with $m=5$. In this case, adequate QoT is achieved, at the expenses of more reserved spectrum in all traversed nodes.

Within IDEALIST, differentiated filter configuration (DFC) has been proposed [Sambo-JLT14]. According to DFC, the passband of the filters traversed by the same connection can be configured to different values. DFC is effective in the presence of detrimental filtering effects. Figure 3(c) shows the proposed DFC solution. In DFC, m can be configured with different values along the path, i.e. different effective bandwidth is configured in the filters traversed by the same connection. In particular, the first and second node are configured with $m=4$, while $m=5$ is applied to last node. This way, no additional detrimental filtering effects are introduced by the third node, and in particular by its filter, which is traversed by the lightpath in its flat region. As a result, spectrum reservation can be minimized on a per node basis according to the expected QoT, thus improving the overall spectrum utilization. Such a technique can be applied both to single carrier and super-channel. Filtering effects can be considered through analytical models (e.g., [Kozicki-OptE10]) or measurements.

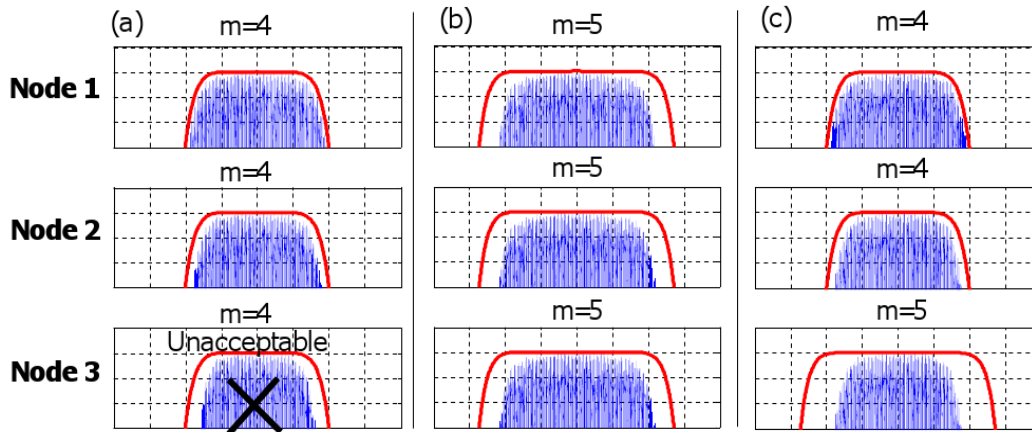

Figure 3: Traditional cascaded filtering with $m=4$ (50GHz, unacceptable filtering effects) (a); or $m=5$ (62.5GHz, acceptable filtering effects) (b); and Differentiated Filter Configuration (spectrum saving and acceptable filtering effects) (c).

A particular case of DFC is the *super-filtering* technique [Paolucci-JOCN14] (proposed within the IDEALIST project), shown in Figure 4, consisting in the aggregation of several independent super-channels within the same filter passband, along common links. In Figure 4(a), a configuration of $S=37.5\text{GHz}$ is applied to the left and right carriers. Instead, the central carrier traverses a filter cascade with only $S=25\text{GHz}$. It is assumed that post-FEC error free performance is experienced by the central carrier when up to $N=3$ filters are traversed, while the propagation through $N=5$ filters with $S=25\text{GHz}$ (as shown in Figure 4(a)) results in unacceptable performance because of excessive filtering distortions. In Figure 4(b), the central carrier traverses a cascade of filters with $S=37.5\text{GHz}$ (as for the other carriers). Propagation through $N=5$ filters results acceptable: the central carrier experiences post-FEC error-free performance. However, with respect to the previous case, the carrier requires larger resources, with a 50% increment of the spectrum reservation. On the contrary, the super-filtering solution (in Figure 4(c)) avoids transition bands for the critical central connection, thus satisfying the QoT and minimizing the occupied bandwidth.

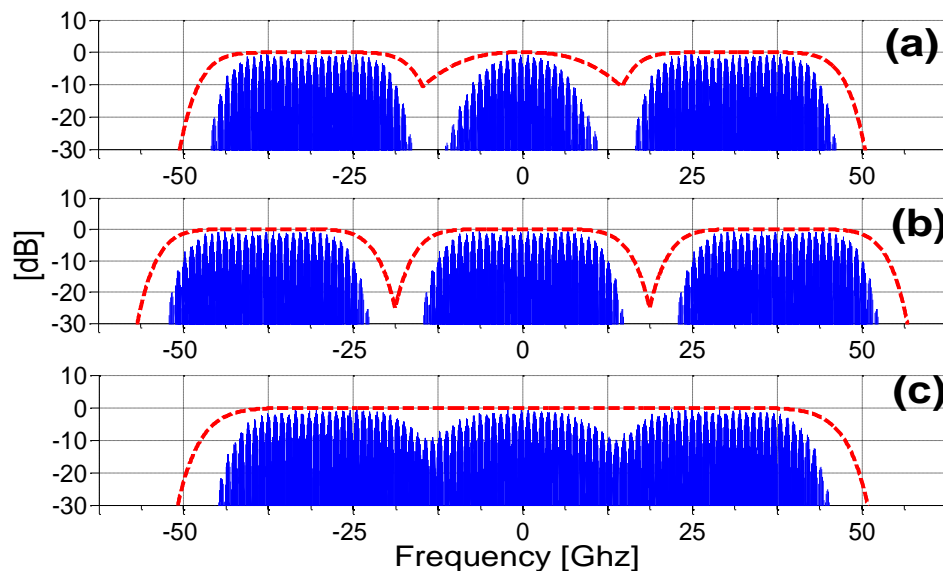

Figure 4: DP-QPSK signals and actual LCoS filter shapes.

4.4.2 Monitoring

Monitoring is essential for the detection and the localization of a failure, and the detection of the affected signals. Consequently, proper actions can be taken so that service level agreement (hereafter SLA) is respected.

The network elements to be monitored are:

- OLA.
- Link.
- Core and edge nodes.
- Photonic node.
- Overall spectrum.
- Optical Channel:
 - Optical Super-Channel (Super-OCh).
 - Optical Channel (OCh).
 - Wavelength.
- Frame:
 - Super-Channel frame.
 - OTN frame.
 - Optical service channel.

In particular, the physical quantities to be monitored and linked to the corresponding network services are:

- Optical power (whole spectrum, Super-OCh, OCh, wavelength). The optical power (dBm) of the whole spectrum or of a network service such as an OCh or a wavelength identifies the status of devices and it can quickly detect a failure. It can reveal a failure in a link or in a node.
- Frequency (wavelength). The measure of frequency (GHz) can reveal some problems in laser stability.
- Frequency deviation (OCh, wavelength). The measure of frequency deviation (GHz) can reveal some problems in laser stability.
- OSNR (spectrum, Super-OCh, OCh, wavelength): it can reveal a failure in a link or in a node (e.g., amplifier malfunction).
- Chromatic dispersion (CD) (wavelength).
- Differential Group Delay (DGD) (Super-OCh, OCh, wavelength).
- Latency/Round trip delay (spectrum, super OCh, OCh, wavelength).
- Pre-FEC BER (Super-OCh, electrical frame).
- Mean square error (sub-carrier). The mean squared error (MSE) of an estimator is defined as the average of the square of the difference between the estimated symbol value and the received symbol value. If coherent detection is used, MSE can be directly monitored through DSP.

Once a problem is detected by the monitoring of one of such physical quantities, the switch of affected services on protection path or dynamic restoration can be performed.

In Sec. 6.4 a more advanced technique based on code adaptation is introduced.

4.5 Elastic Black Link and Multivendor Interoperability

In a Black Link scenario a relevant role to achieve interoperability is undertaken by the parameters already collected in Table 4.1 “Common reference list of parameters for interoperability” of deliverable D2.3 [IDEALIST-D2.3].

More than for the case of a single-vendor network, for a real optical Multivendor interoperability, standardization of the aforementioned parameters is crucial and fundamental, although agreement among different vendors is expected to be hard to achieve.

Here an extract of the most critical parameters is reported:

- **Modulation format:** constellation mapping has to be specifically defined and agreed between vendor A and B for a correct detection.
- **FEC:** only hard decision (HD)-FEC has been standardized [ITU-T-G.709] to date. It is expected that future standardization panels will consider soft decision (SD)-FEC as well. This may improve performance (Figure 5).
- **DSP:** DSP may require standardization in the case of data-aided algorithm [Kuschnerov-PJ10] because of the training sequence to be agreed between transmitter and receiver. On the other hand, if blind DSP algorithms [Kuschnerov-JLT09] are considered, there would be less need for standardization.

Experiments (Figure 5) have shown that if SD-FEC will be standardized, interoperability may be strongly improved achieving performance similar than of single-vendor network [IDEALIST-D2.3].

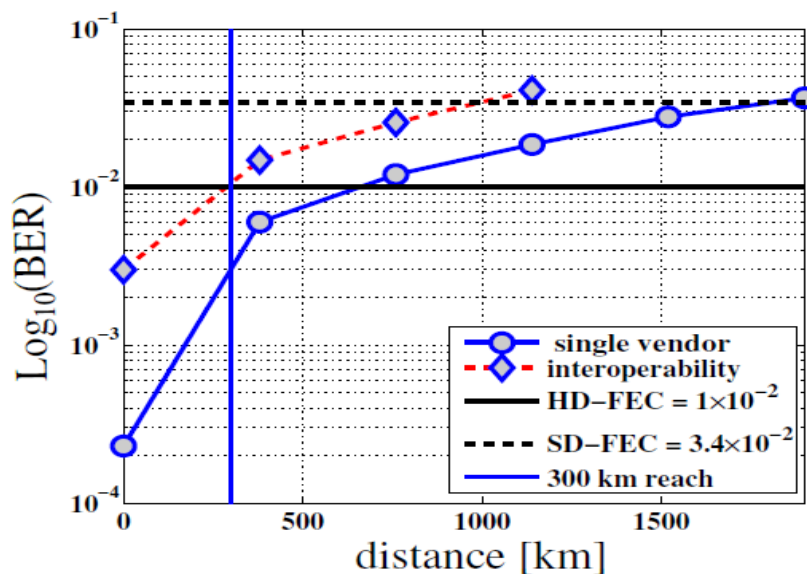

Figure 5: BER vs. distance for single vendor and inter-operability assuming HD or SD-FEC.

4.6 Tools for Optical Network Design

In this chapter are summarized the activities and results carried out during the IDEALIST project concerning the derivation and implementation of tools allowing assessing the system performance of a flexgrid data plane in an efficient way. These tools therefore allow also for derivation of system design rules, which include also the optimizations of the channel power allocation by tuning the optical amplifiers.

In this analysis S-BVTs are considered, which are able to adopt different modulation formats and/or code rates, on the one hand, and dispersion uncompensated transmission links, on the other. Using these assumptions, the system performance can be approximated using the Gaussian noise (GN) model proposed in literature [Poggiolini-PTL11]. This model assumes that the nonlinear distortions can be modeled as Gaussian noise, which is solely described by one parameter, namely its power. Since the amplified spontaneous emission (ASE) noise from the optical amplifiers is uncorrelated to the nonlinear distortion, both noise variances can be summed up in order to estimate an effective (linear and nonlinear contribution) OSNR after the transmission link.

If many simplifications to the system are assumed, like ideal rectangular Nyquist spectra; channel spacing equal to the symbol rate; and equal power of all channels, a very simple, analytical approximation of this method can be used to assess the system performance.

In a first step, these approximations were used and the method was verified with full, time consuming numerical simulations. The results are already reported in Deliverable D2.1 [IDEALIST-D2.1]. These results were used to preselect the most promising system technologies from a data plane perspective targeting different link scenarios. Further simplified “worst case” optical design rules for links in an EON were derived [IDEALIST-D2.1].

However, when considering more realistic flexgrid / flexrate scenarios, such as systems using different channel spacing, symbol rates, channel powers or pulse shapes, this simple analytical approximation is not valid anymore. In these cases, a more sophisticated model (less approximations and simplifications) can be used, but requires numerical integration of the Gaussian noise reference formula (GNRF) [poggiolini-JLT12]. This numerical integration was undertaken and its predictions verified against full numerical simulations. These results are shown in Figure 6 and were already reported in Deliverable D2.3.

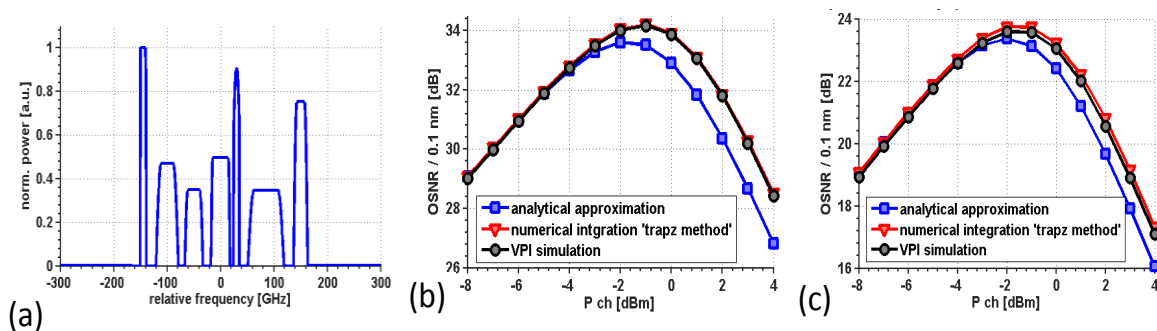

Figure 6: Spectra of investigated WDM signals and resulting simulation results. (a) shows the WDM spectrum for an arbitrarily chosen spectral shape. (b) and (c) show the effective OSNR (including linear ASE noise and nonlinear interference noise) as a function of the fibre input power per channel. Each graph shows a comparison between the different investigated numerical methods. (b) shows the results for a single span, while (c) shows the results for a 10 span transmission. Figure from Deliverable D2.3.

It can clearly be seen from Figure 6 that this enhanced method shows very good agreement with the numerical simulations and is therefore very well suited to predict the system performance and to derive system design rules from it.

However, in order to enhance the usability of this tool, a graphical user interface (GUI) was implemented as a frontend for the Gaussian noise model. This GUI provides a simple interface for arbitrary WDM spectra and link configurations as input parameters. A screenshot of the GUI is shown in Figure 7.

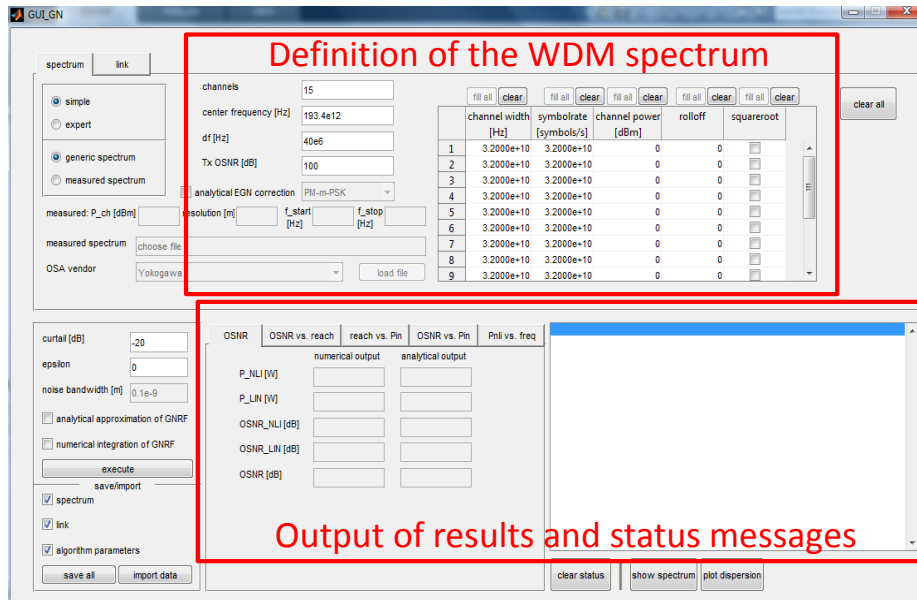

Figure 7: Screenshot of the implemented GUI which acts as an input frontend for the Gaussian noise model.

It can be seen that the channel' parameters, such as the channel width, the symbol rate, the channel power and its shape can be specified independently for each channel in a simple manner. The same is true for the different spans of the transmission link (not shown in Figure 7). Span parameters such as attenuation, dispersion, nonlinear coefficient and length can be specified independently for each span. Also different amplification schemes including pure EDFA amplification, ideal distributed amplification as well as a combination of EDFA and backward Raman pumped spans can be considered. With the help of this developed tool, we are able to predict the system performance of a wide range of different systems and link configurations in a very simple, fast and convenient manner. Further, the goal of deriving system design rules in order to enhance the capacity of an elastic optical network is successfully reached.

As another method for specifying the input WDM spectrum, there is also the possibility to load a measured spectrum from an optical spectrum analyzer (OSA) into the GUI. We used this feature to verify the prediction of system performance not only by numerical simulations, but also in case of experimental data. We recorded and stored the WDM spectrum after the transmitter and used this measured values as an input to the Gaussian noise model. After taking the measured back-to-back implementation penalty of the system into account we were able to predict very well the quality of an optical DP-16QAM signal after transmission [Rahman-OECC15]. The results are shown in Figure 8.

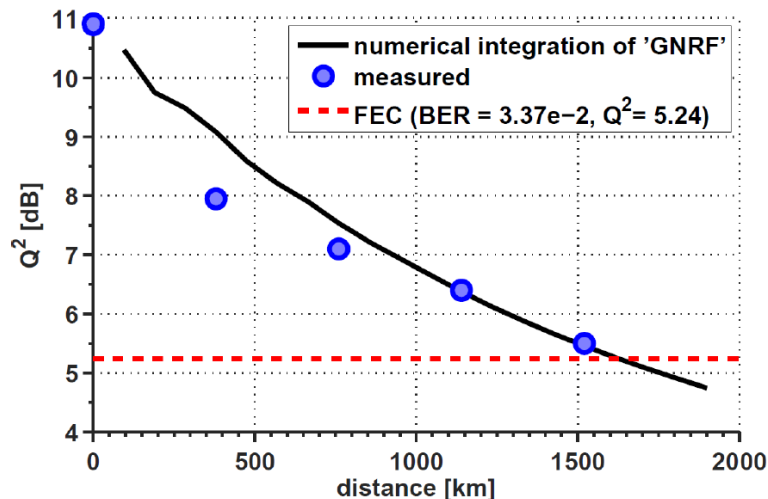

Figure 8: Squared Q-factor as a function of the transmission distance. The blue dots show the experimentally obtained results, while the black curve shows the predicted results by the Gaussian noise model. Graph from [Rahman-PhSw15].

It can be seen that the prediction of the transmission performance is worse for short transmission distance, since the approximations made by the GN model are not valid as long as the accumulated chromatic dispersion is low. However, as the transmission distance increases and therewith the accumulated chromatic dispersion, the prediction and the measurements show a very good agreement.

New approaches were proposed to also include the modulation format of the different channels into the model [Carena-OptE14] [Dar-JLT15]. These approaches would add value to the implemented tool, however require more complex computations and would therefore lead to an increased, and maybe unacceptable, computation time. Another valuable extension would be to include additional distortions due to the filter effects caused by ROADMs (already discussed in Deliverable D 2.3) into the model. This is still an interesting task for further investigations.

Ideally this performance analysis and system design tool should be independent and valid for all the proposed transmission techniques considered within IDEALIST (NWDM, TFP and OFDM). However, while this method seems to work very reliable for NWDM systems, we encountered issues in using it to predict the performance of TFP and OFDM systems.

Regarding OFDM, a coherent optical OFDM has been simulated and its performance compared with the simplified formula of the GN model that can be found in [Poggiolini-JLT14]. As a first step, the simplified GN model has been numerically implemented and compared with the results reported in [Poggiolini-JLT14] in order to validate it. For the OFDM simulations, a 5 WDM channels system has been simulated employing the same transmission parameters suggested in [Poggiolini-JLT14]. Precisely, PM-OFDM signals, running at 32GBaud, with 64 QPSK-modulated subcarriers have been simulated for different channel spacing values and employing a single mode fibre. BER was measured by statistical error counting over 217 bits. Results are summarized in Table 4, where we can see the maximum number of SMF spans (120km each) that ensure a BER below 1.7×10^{-3} . Results show a mismatch of around 15% between the simulations and the reach predicted by the model. In fact, the proposed GN model is based on the assumption that the dominant interaction of nonlinear effects is FWM. Nevertheless, OFDM signals experience a significantly higher peak-to-average-power ratio (PAPR) than single carrier

signals (e.g. NWDm). Such PAPR boosts self/cross-phase modulation effects after propagation, significantly limiting the performance [Inan-ECOC10]. Thus, the GN model should also include these effects in order to be suitable for OFDM signals.

Table 4: Summary of the simulation results when comparing OFDM with the GN model prediction.

Channel Spacing	Max. num. spans OFDM	Max. num. spans GN model
33.6 GHz	27	34
35 GHz	28	34
40 GHz	33	35
45 GHz	31	35
50 GHz	29	36

4.7 Sustainable technological path for (S)-BVT realization

This section presents an investigation on the costs and the power consumption of S-BVTs, considering components and integration through CMOS technology.

It has been shown that S-BVT may reduce its cost by providing the functionalities of multiple transponders into a platform including several integrated elements [Jinno-ComMag12] [Lopez-JOCN14] [Sambo-ComMag15]. This analysis identifies that the cost and the power consumption of the transponder is mainly related to the cost of digital signal processing (DSP). Furthermore a comparison is provided with single 100Gbit/s cards, highlighting the cost reduction provided by a 1Tbit/s S-BVT. Finally, analysis is carried out on the relevance of sub-carrier generation in S-BVTs.

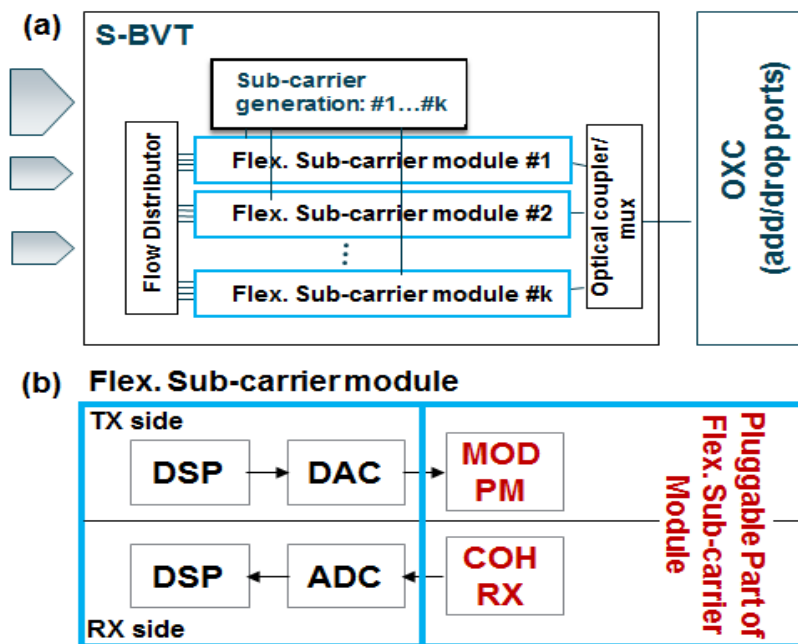

Figure 9: S-BVT architecture (a); Sub-carrier module (b).



The S-BVT architecture, [Sambo-ComMag15], presented in Figure 9 is considered for cost analysis.

At the transmitter side, clients from electronic layer (e.g., Optical Transport Network, OTN) enter the S-BVT to modulate optical sub-carriers. The sub-carrier generation module is in charge of generating up to N sub-carriers (i.e., the maximum number of optical flows the S-BVT can support). Such module may be composed by an array of N lasers or a multi-wavelength carrier generator (See Appendix 8.1). The Flex sub-carrier module is responsible for sub-carrier modulation (or, at the receiver side, for sub-carrier demodulation) and it is expanded in Figure 9(b). At the transmitter side, clients are processed through DSP for encoding, pulse shaping (e.g., narrow filtering), and pre-distortion (e.g., against optical filtering effects). Then, digital data are converted to analog (DAC) and enters modulators (MOD), which are fed also by optical unmodulated sub-carriers generated by the Sub-carrier generation module. Polarization multiplexing (PM) is exploited to double the bit rate. Then, optical sub-carriers are multiplexed and injected in the network through an optical add/drop port of an optical cross connect (OXC) or ROADM.

At the receiver side, the Flex sub-carrier module employs coherent detection (CO-RX), analog-to-digital conversion (ADC), and DSP for linear dispersion compensation, clock recovery, resynchronization, and others.

Based on the reference S-BVT model described in Figure 9, a relevant technology challenge lies in the component integration that provides cost reduction as well as physical dimension decrease.

In terms of referenced cost, a figure of merit can be the cost of current 100Gbit/s transponders (supporting only a single optical flow); contributions to the card cost are given by electronic processing for an amount of approximately 70% (mostly due to packaging design and validation) and by electro-optical circuitry (for optical transmission and electrical connection adaptation with the electronic processing circuitry) for an amount of approximately 30%.

Regarding energy consumption, a commercial 100Gbit/s transponder consumes about 80W-100W, mainly to be ascribed (about 70%) to signal processing. The remaining power consumption (about 30%) is mainly ascribed to the electro-optical circuitry.

An assumption is taken that in 5-10 years of technological evolution, the costs and power percentage contributions for future and not yet commercially available S-BVTs based on Nyquist Wavelength Division Multiplexing (NWDM) at 1Tbit/s will remain approximately the same of a 100Gbit/s card.

Electronic processing includes DSP, DAC, ADC, while Electro-optics includes electrical drivers, filters, modulators, coherent receiver, and lasers. If we evaluate the future evolution basing on current discrete assembling approach, the power consumption in a super-channel scales linearly with the number of sub-carriers, e.g. leading up to 800W – 1000W for a 1Tbit/s super-channel based on 10 sub-carriers.

In the aim to reduce power consumption and cost, the electronic technology realizing signal processing ASICs, should scale down to 28nm from today 40nm. This is in line with the last advances of CMOS technology and can lead to 20% - 30% of power per bit saving. In terms of cost, the downscale from 40nm to 28nm with an approximately same level of yield of production and volumes, may lead to a cost saving per transmitted bit of at least 40% - 50% for the electronic processing, by doubling the number of functional components integrated on the same die.



Photonic integration can further help, e.g. sharing thermal control and power dissipation functions among a subset of sub-carriers, but with the current hybrid approach the contribution to the total power saving will be lower than 10% with negligible reduction of cost of production.

More promising is the CMOS photonics which will evolve in the next 5 - 10 years, scaling from current 130nm down to 90nm SOI CMOS process (e.g. with a single lithographic process hundreds of photonic components can be integrated with millions of transistors due to higher resolution CMOS process in realizing modulators and photo-receivers, consequently power reduction will be experienced) [Guckenberger-ECOC10] [Assefa-IEDEM12] [Buckwalter-CICC11]. Substantially the CMOS technology applied to photonics allows for a well-adapted matching between the electronic part (e.g. DAC, ADC, DSP, FEC, drivers) and the optical section (e.g. modulators, photodiode, laser source) leading to optimization of performances and energy efficiency scaling down power consumption per bit by 20% - 30% and further 40% - 50% of cost saving per bit can be obtained.

To further increase overall energy efficiency the electro-photonic functions can be more efficiently driven by the processing circuitry if wafer to wafer bonding basing on 3D integration process [Arakawa-ComMag13] is applied by significantly reducing power leakage. Further 30% of overall power saving is possible [Arakawa-ConMag13].

Furthermore, designing the Terabit card to host up to ten transmission lines, each at 100Gbit/s, the power supply and control unit is shared and not replicated for each capacity. This aspect, also leveraging on the introduced 3D integration optimization, can lead to an additional 40% of power saving to the 30% due to CMOS technology scaling and this without significant cost increments.

Taking all factors into account, the total power saving on the whole device is around 70%. For the analysis a pay as you grow approach is assumed considering an S-BVT supporting a maximum of 1Tbit/s and composed of a maximum of ten 100Gbit/s Flex sub-carrier modules. Hence, after each 100Gbit/s increment of traffic, a pluggable module (see Figure 9(b)) is added on the S-BVT as far as the maximum capacity of 1Tbit/s of information is reached. Each increment step leads to an incremental step of cost and power consumption of the installed S-BVT.

Once the maximum capacity is reached, another S-BVT should be installed to host the incremental step of traffic flow. The maximum capacity of 1Tbit/s has been defined by taking into account the maximum sustainable power consumption that a single line card can accept to be fully operative in rack hosting several cards of the same dimensions. A reasonable value can range between 200W and 300W. Based on the power consumption analysis results, the outlined line card consumes 240W - 280W (i.e. 70% saving with respect 10x100Gbit/s transponder power consumption), well within the justified reasonable range. Thus, once the S-BVT is installed in a rack performs a basic power consumption equal to 72% of the predefined maximum power consumption and overall cost which is ascribed to the integration on board of DSP's and Sub-carrier generators (i.e. 2% are ascribed to multi-wavelength source as explained in the Appendix 8.1). This basic power consumption is then updated at incremental step of 2.8% (around 7W - 8W) of the S-BVT maximum power and overall cost after each electro-optical module is plugged to add more capacity of transmission. In case of 10 plugged modules, the maximum increment is around 28% of the maximum S-BVT power consumption and cost.

The so fashioned evolution can be summarized in Figure 10 and Figure 11 for the cost and the power consumption, respectively. The transmission system is evaluated up to 10Tbit/s of information corresponding to a maximum number of 10 S-BVTs at 1Tbit/s. The cost

analysis is expressed as normalized with respect to the cost and power consumption of current 100Gbit/s transponders. The results show cost reduction per bit transmitted equal to 40% and the power saving equal to 70% with respect to 100Gbit/s technology at each 100Gbit/s capacity upgrade in the optical transmission system.

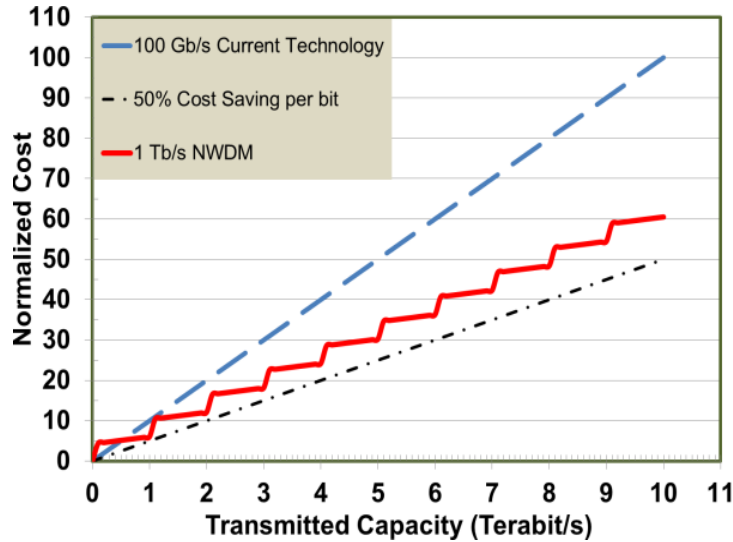

Figure 10: Cost analysis versus capacity upgrades.

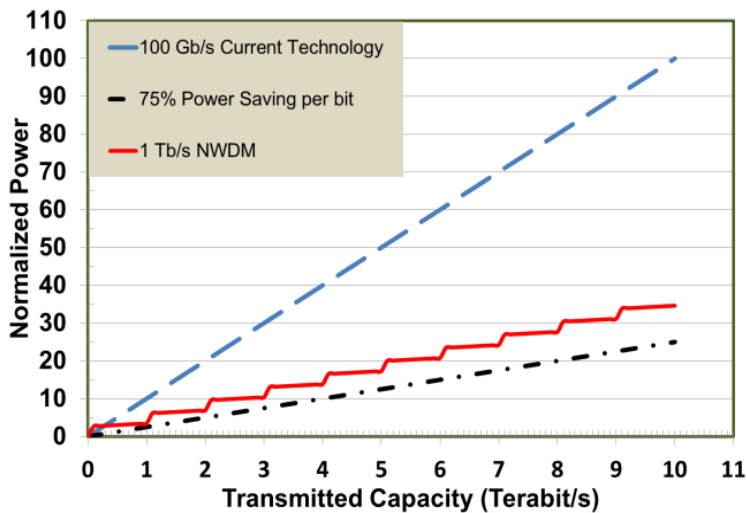

Figure 11: Power Consumption vs capacity upgrades.



5 Solutions for Metro Area Network and Interconnection with Backbone

There are multiple sub-areas within the EON framework, hence a large amount of solutions have been proposed to address the different requirements of each sub-area. In particular, the core networks typically require high bit rate connections over thousands of kilometers while metro connections exhibit shorter reach (a few hundreds of kilometers) and lower bit rates. In this context, elastic interfaces and nodes are beneficial to the deployment of these types of EONs. In particular, elastic optical nodes that lie on the border of the metro and core network domains are relying on flexible aggregation supported by the elastic interfaces (Section 5.1) and on elastic cross-connects (Section 5.2) to be more cost-efficient and capacity-optimized. Moreover, the inherent fine granularity of OFDM signals is an alternative way of handling flexibility of incoming client flows and, when combined with a low-cost direct-detection receiver this is found to be a very promising solution for metro area networks with BRAS (Section 5.3).

5.1 Elastic interface for Metro/Core Border Node

The interconnection of metro and core network domains often requires multilayer capabilities to better fill the optical layer pipes: this is obtained with grooming and aggregation of circuit and/or packet flows (layer 1 or layer 2) onto optical wavelength (layer 0).

Today, flexible aggregation supports only flexibility at the digital layer, i.e. at the optical data unit switching (ODU), through a mechanism called ODUflex. However, in the resulting line rate with optical channel transport unit (OTU), the transported line rates are fixed, e.g. OTU2 carries 10Gbit/s signals and OTU4 carries 100Gbit/s. However, the elastic optical network provide a more efficient and flexible use of the optical spectrum thanks to the employment of flexible transponder cards supporting a wide range of bit rates, e.g. from 50Gbit/s with DP-BPSK up to 200Gbit/s with DP-16QAM or even 400Gbit/s with DP-64QAM.

To bridge the gap between the transported line rate and the ODU layer, OTN standards are now currently under discussion to provide more flexibility at the OTU level for beyond 100G. This will fully leverage the flexible transmission parameters of the physical layer in order to optimize simultaneously the data rate, the reach and spectrum occupancy.

Regarding OTN standards, the beyond 100G OTN new frame called OTUC_n (with a variable parameter “*n*”) is evolving so as to carry the expected 400GbE clients. Only a few values of “*n*” will most likely be standardized beginning with “*n*” = 4. However, more flexibility in data rates is being discussed and this might change. A most likely target is 2018 for such an evolution.

In more details, as we are heavily involved into definition of the so-called “beyond-100G-OTUflex”, in ITU-T, for instance, during recent discussions, it has been noticed that the line interfaces are not necessarily a multiple of 100G, such as 150G. For that reason, it was decided to describe this kind of interface as an OTUC_n-*M*, where *n* is similar to OTUC_n and represents the number of (100G equivalent) units of overhead columns, and *M* is the number of 5G tributary slots supported. The exact frame format is not specified and non-multiple of 100G rates are single vendor interfaces only. As an illustrative example the



150G signal would be an OTUC2-30 since it only carries 30 tributary slots instead of the 40 that would be carried by a full OTUC2.

One main achievement of the IDEALIST project is the first worldwide prototype of the Beyond-100G concept [Dupas-OFC15]. To accommodate the best in class FPGA-based evaluation board, we scaled down the bit rate but still demonstrate a proof-of-concept of interleaving a varying “ n ” OTU frames to deliver a variable bit rate from 10Gbit/s up to 100Gbit/s by steps of 10Gbit/s. The DP-QPSK signals with a variable symbol rate is thus bandwidth variable whose advantages are “just-enough” spectrum occupancy as well as energy consumption if symbol rate variation is implemented with a variable frequency clock. Live experiments show an OTU rate and line rate adjustments with a sub-millisecond reconfiguration time [Dupas-OFC15].

For longer term aggregation solutions, OTN and Ethernet standard bodies are both expected to target the 1Tbit/s bit rate beyond 2020. FlexEthernet is now actively discussed and becomes a new hot topic for future innovation. It will most likely help EONs to become more dynamic, with more automation. The main drivers of flexEthernet are use cases where core transport becomes more expensive than clients. FlexEthernet is a way to match the transport flexibility that appears with EONs since it is more efficient than existing LAG mechanism.

The metro/core border node also relies on flexible transponder technology that has been previously described in Section 4.3.2 for what concerns medium/long term targets.

5.2 Elastic Cross-connects (EXCs) and BV-WSSs

Today, elastic node architectures can be obtained by performing a simple upgrade of components. To support elastic spectrum allocation, static ROADM node architectures have been proposed by replacing the fixed-grid WSS with a bandwidth-variable WSS (BV-WSS). These suggested EON node architectures suffer from scalability limited to a few degrees, complex spectrum fragmentation, and the need for additional components, such as large port-count switches, to provide extra functionalities (time multiplexing, regeneration, etc).

To enhance metro EONs, future elastic cross-connects (EXCs) -beyond 2020- will be employed for increased flexibility in the network and interconnectivity with the backbone. The basic EXC architecture must include elements that allow easy all-optical cross-connection from any input port to any output port so the EXC can behave as a node element and the node degree will be determined by the available ports in the node for line connections together with the ports used for connectivity of additional functional modules. In addition, the nodes must be able to accommodate traffic coming from the different domains.

Considering these emerging requirements, and addressing the issues presented above for metro nodes and nodes for interconnection of metro and backbone, within IDEALIST, the AoD node is proposed and adopted, as presented in section 6.2. More importantly, within the IDEALIST context, the AoD-based EXC node supports flexgrid or gridless network domains since different BV-WSS modules can be added to the AoD structure whenever and wherever required. Based on the AoD node and in combination with BVTs with interfacing capabilities (e.g. with the elastic interface OTU2 channels can be interleaved into an OTU4 channel with different bit rate capacities), the implementation of a border node is simplified allowing the interoperation in between different network domains such as

metro and core domains. These multilayer capabilities have been reported in [Gonzalez-ECOC15] with integrated data and control plane networks including the AoD-based EXCs, BV-WSSs and the elastic interface aforementioned.

5.3 Solution for traffic aggregation in the metro/regional network domain

The advent of elastic optical networks and the advance of transmission techniques in terms of flexibility and capacity has led to undertake new challenges and goals, enabling the introduction of sliceable super-channels as well as the reduction of channel width for low bit rate connections. This granularity is especially useful for an aggregation network. Precisely, the adoption of flexgrid technologies improves spectrum utilization and network efficiency, while reducing CapEx investment. Thus, an evolutionary approach for the metro/regional network segment has been envisioned and novel scenario proposals have been investigated in IDEALIST. As a result, these scenarios have been studied in detail and the results reported in [IDEALIST-D1.5] [IDEALIST-D2.1] [IDEALIST-D2.3], covering several aspects that include the data plane perspective.

As described in [IDEALIST-D1.5] [IDEALIST-D2.3], main network operators are expanding their photonic mesh to the regional networks. So, it has been proposed to extend the aggregation network reach, typically confined to a metropolitan area. This implies the creation of a conveniently dimensioned pool of virtual BRASes co-located with IP core transit routers in the same data center in order to further reduce the cost. In this scenario, it is expected to have a vast number of low bit rate connections from multi-tenant units (MTUs) to these virtual BRASes, featuring a highly centric traffic pattern. Typically, these connections are envisioned to deliver data rates up to 10Gbit/s while occupying the lowest optical bandwidth possible (e.g. a 12.5GHz slot).

As the requirements are different from other applications, using technologies for core networks (e.g. 100G coherent transceivers) is overkill. So, it is proposed to optically aggregate in a flexgrid network the data flows coming from the MTUs towards few sites, where BRASes are located. Each of these sites would contain sliceable bandwidth variable transponders in order to concentrate all the traffic [Svaluto-ONDM14]. For example, in [IDEALIST-D1.5] it is proposed to use 2 BRASes (one operative and another redundant) for each region of the Spanish national network model provided by TID. In that scenario it is envisioned that each BRAS site gives service to up to 200 MTUs, with a worst case path of few hundreds of kilometres featuring 6 hops; which gives an idea of the data plane requirements.

In order to cope with those requirements, several transceiver architectures have been investigated and compared. A first study was reported in [IDEALIST-D2.1] and [Svaluto-ECOC13] [Svaluto-ONDM14]. There, a cost-effective BVT design was numerically and experimentally assessed. Limiting factors, such as PAPR, available bandwidth, dispersion impairments and linearity of the subsystem components were taken into account in the BVT design guidelines. Also, bit loading schemes and guard band minimizing were proposed for distance adaptive transmission, considering up to 10Gb/s connections and 12.5GHz channels. In order to further enhance the cost effectiveness, an asymmetric transmission architecture was investigated and reported [IDEALIST-D2.3] [Svaluto-ECOC14] [Fabrega-OFC15], also coping with the proposed requirements. The solutions approached were envisioned to give service to several MTUs using cost-effective S-BVT(s) at the BRAS side, which should be both cost-effective and robust against transmission



impairments, in order to support multiple low bit rate connections over regional optical paths. Along a different line, simple BVTs, transmitting amplitude modulation modulated DMT signals and featuring direct detection, were envisioned at the MTU side. Experimental studies of those approaches were carried out within the ADRENALINE testbed of CTTC. Precisely, 10Gbit/s connections between BRAS and MTU(s) were assessed in different configurations. Experiment details and results can be found in [Svaluto-ECOC14] and [Fabrega-OFC15] for the BRAS-MTU connection (downstream) and MTU-BRAS connection (upstream), respectively.

Additionally, OFDM signals with direct detection are compared to simple 10G transceivers featuring IM/DD OOK, since they constitute the most cost-effective transceiver architecture, despite the fact that they need dispersion compensation and further regeneration in order to cope with the typical distances of a regional network. Since these facts are well known and characterized, we focus our comparison on another issue: the filter narrowing effect. Results are reported in Appendix 8.2, showing that OFDM BVT is a feasible candidate, as it provides increased flexibility, thanks to its ability to adapt the bit loading profile to the channel response, including the filter narrowing effect.

In summary, cost-effective flexgrid technologies have been assessed for a MAN scenario with centralized BRASes. Experimental results show successful 10Gbit/s net connections from BRASes to the MTUs and vice versa, when serving different paths and covering distances up to 185km. Further simulation results show that the proposed systems can also cope with typical regional network distances. Thus, the combination of the proposed architectures for up/downstream communication constitutes a promising solution for serving the multiple endpoints using S-BVT(s) at the BRASes according to the topology requirements.

6 Long term perspective methodologies, and solutions

This chapter reports the studies undertaken in IDEALIST relevant to the design and operation of EONs. As a result of these studies, methodologies and solutions are provided which consider the long term vision of an EON.

A particular figure of merit is studied in here: Flexibility. This figure of merit is of significant value since it directly corresponds to the definition of elasticity within EONs. Furthermore, this flexibility figure of merit is related to other parameters of the EONs such as spectral efficiency, connectivity, etc. In addition, the architecture on demand concept is described in this chapter as a solution to accommodate the dynamic and unpredictable future network traffic. Moreover, regeneration and defragmentation options are studied and analysed under the SERANO platform. Different algorithms are shown exploring the SERANO capabilities. A physical layer performance of SERANO is also presented in this chapter. With regards to defragmentation, a push-pull technique is proposed within IDEALIST. Finally, for this long term EON solution, advanced monitoring and control capabilities have been also explored under the IDEALIST framework.

6.1 A Figure of Merit for flexibility assessment

In EONs, high levels of flexibility of network resources are desired to cope with more dynamic and unpredictable growth of traffic contributed from sources stretching from Data Centers to the Internet of Things.

A new method of equipping networks with the necessary technologies has been introduced through a figure of merit flexibility [Amaya-JOCN13]. This figure of merit quantifies the flexibility of different node components considering maximum entropy. Based on this flexibility, ROADMs can be accurately designed without exceeding the use of resources and still enabling network operators to manage the unpredictable traffic addressing wavelength channels between optical nodes.

Overall system flexibility measurement relates to different functional technologies. One of these technologies is the WSS, which has emerged as a key building block of the fixed-grid ROADM design and can be upgraded to BV-WSS to support elastic spectrum allocation. In addition to the WSSs/BV-WSSs, the multicast switch (MCS) has also been recently proposed as a technology for implementation of CDC attributes in ROADM architectures, as mentioned in section 4.2 [Way-OFC12]. Several studies have proposed and demonstrated flexible Add&Drop network structures to improve flexibility and functionality of optical node operations as well as to deliver CDC functions [Way-OFC12] [Gringeri-ComMag10] [Garrich-OFC14]. In particular the flexibility of different Add&Drop structures considering the drop direction only were measured and evaluated in [Garrich-OFC14].

Similarly, BVTs with adaptability to different parameters, such as bit rates, spectral occupancy, transmission reach and connectivity; are important building blocks that further enhance the flexibility of the ROADM (Figure 12). Figures of merit for independent $N \times M$ WSSs, $N \times M$ SSSs (or BV-WSSs) and BVTs have been reported in [Peters-OFC15] where different design of optical devices with different levels of flexibility and its connectivity, capacity, spectral efficiency and granularity are shown.

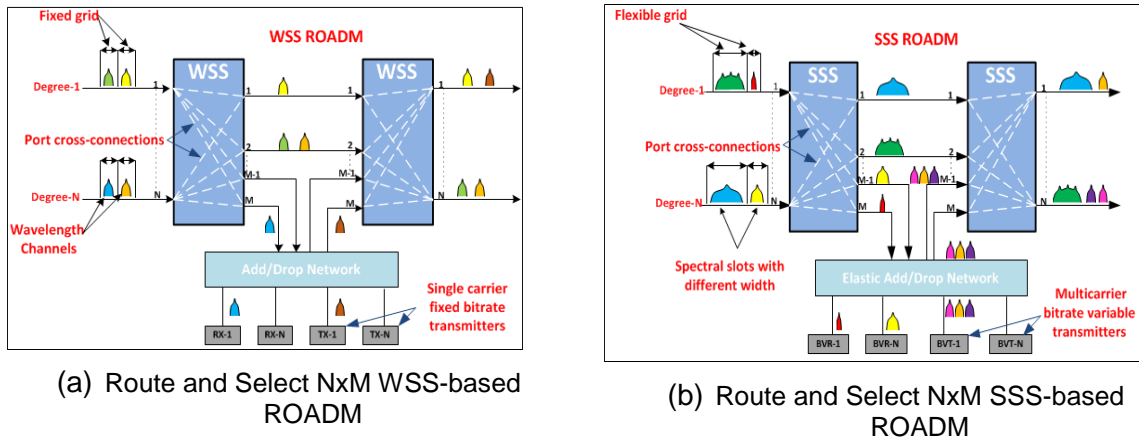

Figure 12: ROADM architectures for flexibility measurement. Route and Select NxM (a) WSS-based ROADM and (b) SSS-based ROADM.

Results of the flexibility measurement, at the component (device) level, and the comparison with other figures of merit are included in Appendix 8.3. To further enhance the flexibility measurement, different component flexibilities (i.e. BV-WSSs, BVTs) are grouped and consolidated at the subsystem level to form complete Add&Drop systems. Furthermore, the comparison and trade-offs among different subsystem figures of merit also need to be studied, providing an advanced visualization structure for designing future ROADMs and EONs.

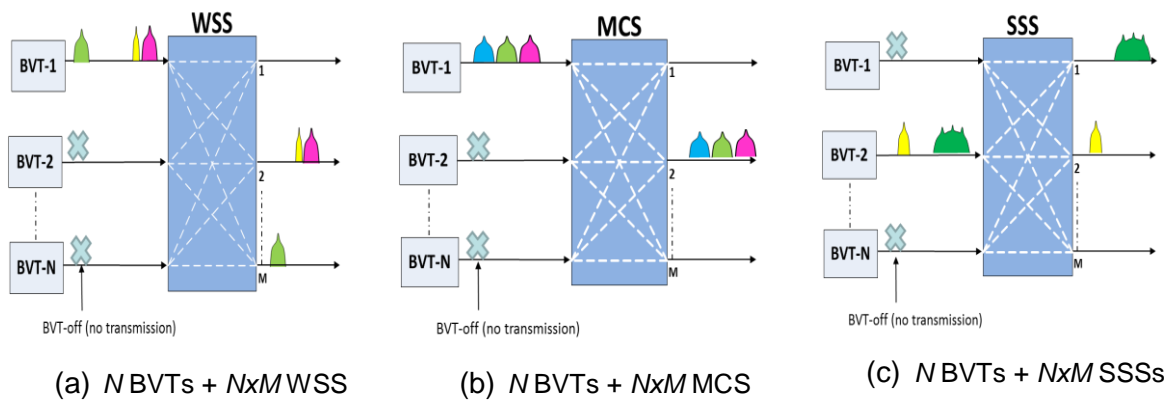

Figure 13: Different add/drop network subsystem with BVT designs.

As an example, Figure 13(a) demonstrates a subsystem made up of N BVTs and $N \times M$ WSS. Each BVT is a flexible multicarrier transmitter in fixed grid networks with variable transmitter attributes. Different numbers of optical channels with variable bandwidth can be fed into the N input ports of the WSS which can be independently switched or blocked across M output ports. The subsystem in Figure 13(b) consist of N BVTs and $N \times M$ MCS. The BVTs design employs the same working principle as the BVTs described in Figure 13(a), however the MCS implemented using optical switches and optical splitters only provides space switching functions thus all optical channels from a BVT can only be switched to one of the output ports at a time. Figure 13(c) illustrates a third subsystem design for EONs where the BVTs are also multicarrier transmitters with variable attributes but have finer spectral tuning capabilities. Thus, multiple traffic flows with variable



bandwidth/spectral occupancy are generated and inserted into the SSS which can independently configure the slots across M number of output ports.

Here, a subsystem is the combination of two or more optical components that have different levels of flexibility, thus the resultant flexibility of the subsystem varies and depends on the configuration of components as each component provides a different type and level of flexibility. Detailed description of how the subsystem flexibility models were obtained is described in Appendix 8.3.

Table 5: Different subsystem configurations.

Subsystem Config	No of carriers per BVT	Wavelength channels/ Spectral slots	Modulation formats	Symbol Rates (Gbaud)	Maximum Bitrate (Gb/s)	Maximum Spectral efficiency	Minimum Granularity (Gb/s)
8 BVT + 8 x12 WSS	8	80	BPSK,QPSK, 16QAM, 32QAM, 64QAM	30	1440	3.6	30
8 BVT + 8 x 24 MCS	10	80	BPSK,QPSK, 16QAM, 32QAM, 64QAM	14,18,22 26,30	1800	3.6	14
4 BVT + 4 x 16 SSS	10	160(slots)	QPSK, 64QAM	14,18,22 26,30	1800	4.8	28

In Table 5 the parameters of the subsystem are varied and the flexibility of each subsystem is measured and compared with different performance metrics which is displayed in Figure 14. We observe key design trade-offs between flexibility and other performance metrics. The fiber connectivity of the subsystem is equal to the number of output ports which can be connected to different fibers and the optical carrier connectivity is equal to the number of optical carriers that can be sliced to different destinations. It is observed that the Subsystem 4 BVT + 4x16 SSS provides the lowest flexibility and, it has an equivalent capacity to the 8 BVT + 8x24 MCS but a higher spectral efficiency due to improved spectrum utilizations at a spectral slot slice of 12.5GHz. The 8 BVT + 8x24 MCS has the highest flexibility and fiber connectivity, however it has the lowest optical carrier connectivity due to the fact that the MCS only provides space switching functions and cannot independently slice optical channels to different output ports. Additionally the 8 BVT + 8x24 WSS has the second highest flexibility and has a higher optical carrier connectivity than 8 BVT + 8x24 MCS but a lower fiber connectivity.

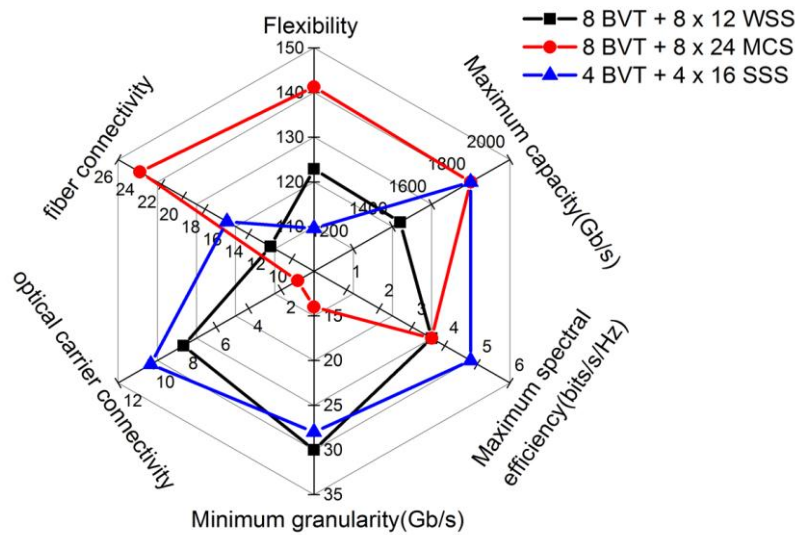

Figure 14: Comparison of different subsystems with different configurations.

6.2 Architecture on Demand

Considering long-term solutions, within IDEALIST it is envisioned that current OXC or ROADM structures will be limited and will not be able to cope with the dynamic and unpredictable network traffic. Therefore, the architecture on demand (AoD) node concept is suggested as a possible solution considering the requirements and restrictions of current OXC architectures.

Traditional OXC architectures that switch traffic at the wavelength level necessitate a large number of ports as the amount of traffic increases. In order to reduce the number of required ports, and consequently the cost and control complexity, multigranular OXC (MG-OXC) has been proposed in [Wang-COMMS&T12], which performs fiber, waveband, or wavelength switching. Similarly, colorless, directionless and contentionless reconfigurable optical Add&Drop multiplexer (CDC-ROADM) architectures have been proposed in [Gringeri-ComMag10]. In CDC-ROADMs, ports are not associated with any specific wavelength or node degree and multiple ports can simultaneously add and drop different channels at the same wavelength. In addition, the CDC capabilities enable us to eliminate the manual intervention by a technician, compared to the first generations of ROADMs. Furthermore, to enable the elastic allocation of spectral resources, bandwidth variable reconfigurable optical Add&Drop multiplexers (BV-ROADMs) have been presented in [Jinno-ComMag09].

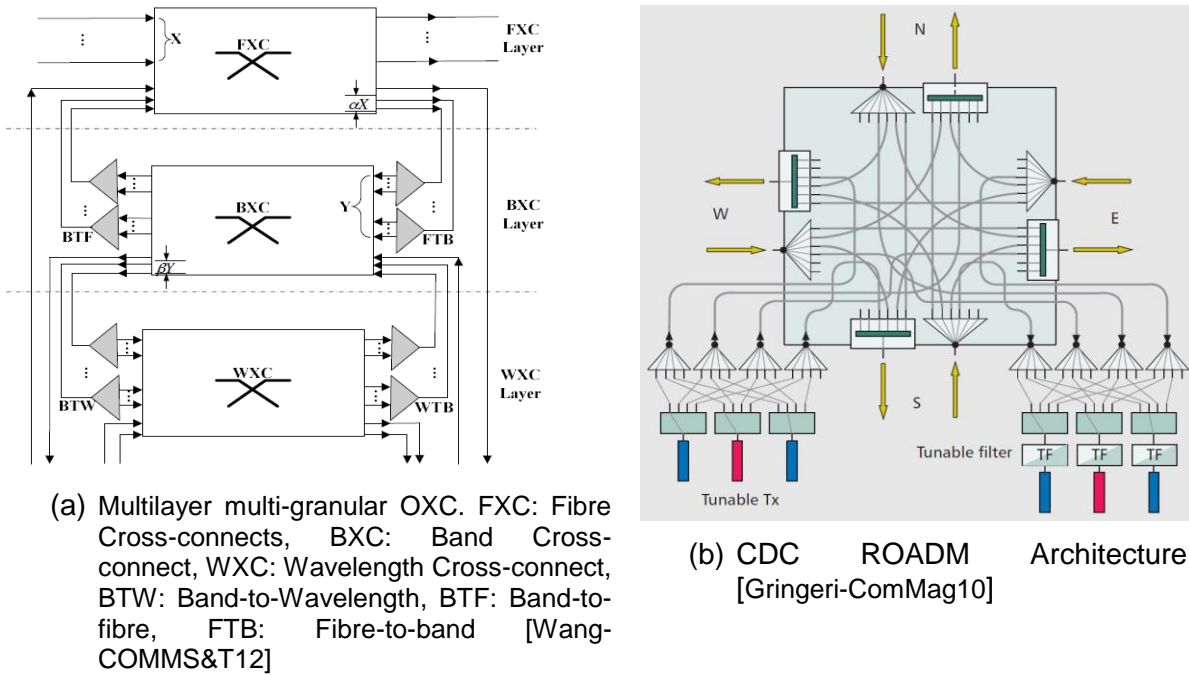

Figure 15: Traditional OXC and ROADM Architectures.

However, these approaches have three major drawbacks. First, they often comprise hard-wired arrangements of switching modules, which restrict the upgradeability, limit the support for new functionalities, and curb the capability of adapting the architecture to the network requirements. Second, the reported architectures are designed with the scope of providing service per granularity (i.e., degree, port, waveband or wavelength). The direct implication of such a design is to deploy devices per granularity. As a result, these architectures are constrained by the number of required devices and by their port count. Third, the non-adaptable nature of these ROADMs inflicts high power consumption. Some components of these systems, for instance, common equipment in the case of ROADMs [Autenrieth-ICTON11] and devices in OXC architectures [Murakami-ICTON09], contribute to power consumption regardless of the traffic variations or network requirements.

The architecture on demand (AoD) node [Amaya-ICTON11] overcomes these limitations by dynamically adapting its architecture according to the switching and processing requirements of the network traffic (Figure 16). AoD provides much higher flexibility than the above-mentioned architectures as the OXC modules are not hard-wired like in a static architecture, but can be interconnected together in an arbitrary manner and critically are decoupled from input/output links. Thus, each node (and the network as a whole) behaves like an optical field-programmable gate array (FPGA) with optical components rather than gates.

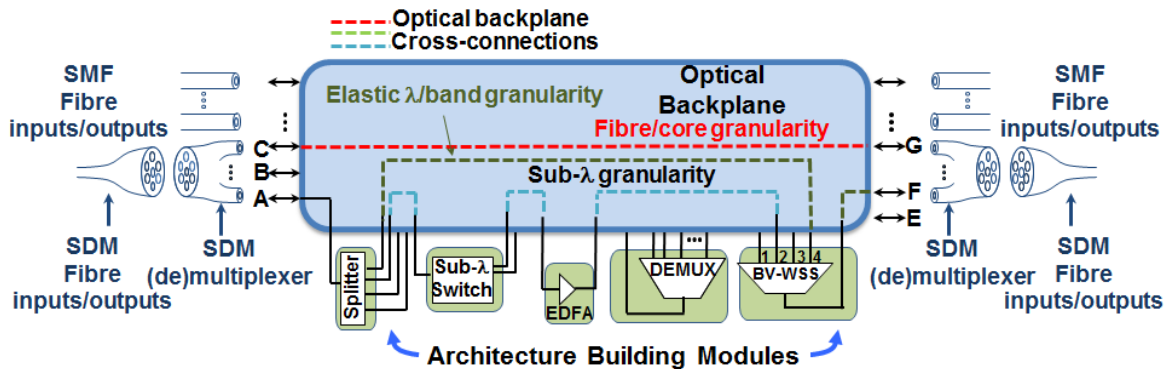

Figure 16: Architecture-on-Demand Node.

Several demonstrations have validated the AoD concept and its ability to compose and provide on-demand functionality, such as spectrum defragmentation [Amaya-ECOC11] and multidimensional switching in space/frequency/time by use of multicore fibers (MCFs) [Amaya-ECOC12] [Amaya-JOCN13]. Moreover, AoD has been shown to provide considerable gain in terms of scalability [Garrich-ONDM12], power consumption [Garrich-ECOC12], and resiliency [Dzanko-ICTON12] [Dzanko-ECOC13] compared to conventional hard-wired static architectures.

The versatile feature of AoD enables the OXC to switch optical signals in a given input without utilizing any demultiplexing and multiplexing device (i.e., fibre switching) if all these signals traverse through to the same output with no signals from other inputs. In such a case, only a cross-connection in the optical backplane is used for connectivity between the input and output. By exploiting this feature, not only can the number of hardware modules be reduced by half [Garrich-ONDM12], but also notable power savings [Garrich-ECOC12] can be attained for AoD compared to conventional architectures. Hence, AoD is a promising solution for future high-capacity flexible and evolvable networks. Research in [Garrich-ONDM12] [Garrich-ECOC12] investigated the switching requirements for input traffic at the node level without analyzing the savings in hardware modules, power consumption, and scalability issue at the network level. Also, research in [Muhammad- JOCN14] investigates the composition and synthesis of cost-efficient architectures for networks equipped with AoD OXCs by exploring the flexibility inherent in AoD. The cost of the network can be reduced by properly routing and assigning spectrum to traffic demands in such a way as to maximize fiber switching. Such a planning and synthesis strategy will compose and dimension the network by allocating components functions on a per-node basis. As a result, it lowers the number of switching modules and minimizes the number of cross-connections in the optical backplane for provisioning a given set of traffic demands. In addition, by reducing the number of switching components the power consumption of the network will also be lowered. The summary of the AoD features are included in reference [Hugues-Salas-ComMag15].

From the node integration point of view, one important application of the AoD node is the synthesis, placement and configuration of SSSs (BV-WSSs) and EDFAs for different power balancing scenarios [Yuan-OFC15]. The intrinsic use of different modules in the node architecture (e.g. BV-WSS, couplers and optical cross-connections), cause different power losses when the signals traverse different optical components in response to different traffic demands. Thus, it is crucial to perform power balance synthesis of the node architecture by efficient placement and use of EDFAs (gain/output power control) as well as signal-level attenuations using BV-WSSs.

6.3 Regeneration and defragmentation options

In this section the problem of super-channel regeneration and that of super-channel optimization (in term of bandwidth, central frequency, number of sub-carriers, transmission coding, modulation format and so on) on a per-regeneration section basis, is discussed.

Often, especially in national backbones or pan-European networks, regeneration is unavoidable on several optical paths; regeneration of super-channels, if their intrinsic flexibility has to be completely exploited to optimize bandwidth usage in each regeneration section, poses particular challenging problems both to the optical and electronic architecture of regeneration modules, and to the RMSA (Routing, Modulation, Spectrum Assignment) algorithms to design and control them.

The SERANO architecture is here proposed as a possible long term solution of this difficult problem. Its architecture has been extensively discussed in previous IDEALIST deliverables (for example in [IDEALIST-D2.1] [IDEALIST-D2.3]), but the comparison between the different RMSA algorithms options is sufficiently new to devote substantial space to it in this deliverable (sections 6.3.1 and 6.3.2).

Finally section 6.3.3 is dedicated to the discussion of the defragmentation technique named “push-pull” which is an all-optical hitless approach enabling the shifting in the frequency domain and without loss of data, of the central frequency of a super-channel. This technique allows an effective way to reallocate spectrum resources to free adjacent spectral slots for transmission of new media channels.

6.3.1 SERANO solution

As another long-term solution resulting from the IDEALIST project, the SERANO node/module is proposed for super-channels’ optimization on a per-regeneration section basis. This type of node/module extends the architectural framework described in the previous section to efficiently support AoD nodes and EON operations. Thus, the discussion of the performance is described in this section.

In [IDEALIST-D1.3] section 5.1 and [Kosmatos-ECOC14] the performance of a SERANO block associating the internal blocking probability to the number of SERANO active elements (S-BV Rx-Tx pairs connected back-to-back) is introduced and analyzed. It is verified that a statistical use of these active elements allows to substantially reduce the number of them at the expense of finite blocking at the order of 1×10^{-3} .

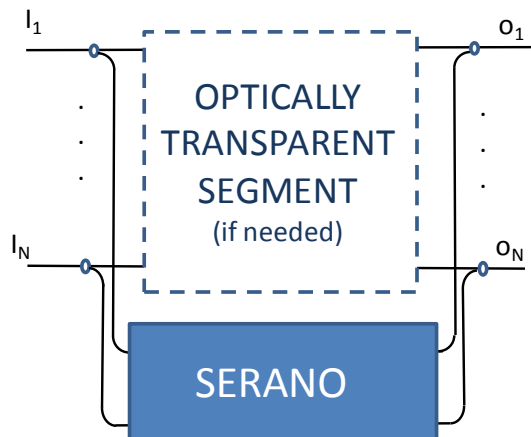

Figure 17: BV-OXC with SERANO bypassing architecture (high level).

In this analysis it is assumed that the SERANO block operates in isolation, i.e. it is the main element of EON node. This is true if the local traffic is in Add&Drop to the node by means of power couplers per I/O fiber as shown in Figure 17. However, when BV-WSSs, or SSSs, are used as the main optical technology to optically transparent forward transit traffic as well as to locally Add&Drop traffic, the picture substantially changes as shown in Figure 18. Importantly, not only the layout is different but also the number of SERANO active elements substantially varies.

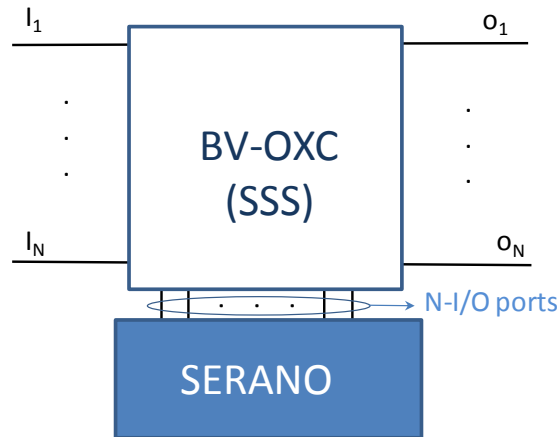

Figure 18: SERANO enhanced BV-OXC architecture (high level).

As one can observe, in Figure 17 the entire channel comb is locally dropped, at the SERANO input, whilst in Figure 18 only the desired group of channels is locally dropped. However, the important difference is at SERANO's output since in the latter case, the outgoing fibers from this block will be forwarded to a BV-WSS (SSS) (Figure 18). This operation allows forwarding any incoming channel (that will be, possibly, converted in terms of its central carrier frequency through the SERANO block) to any of the outgoing SERANO fibers. This new spectral slot will be further routed to the correct outgoing node fiber by means of the BV-WSS. As a result of this operation we have $c=N$ in Eq.3 of [Kosmatos-ECOC14] which means that when the traffic is forwarded to a SERANO block by means of a BV-WSS (Figure 18), the number of SERANO active elements is minimized and it equals the number of transceivers of any conventional electronic switch (OTN, MPLS, IP router) of the same capacity whilst the internal blocking probability is zero.

6.3.2 Developed algorithms for SERANO design

6.3.2.1 RMSA algorithms exploiting SERANO capabilities

In the RMSA (Routing, Modulation, Spectrum Assignment) context, the emerge of SERANO can become beneficial for EON networks in terms of improving spectral efficiency and blocking probability, cost reduction etc., because SERANO -in contrast to other solutions- can exploit the full potential of the RMSA algorithms/mechanisms. In this direction, the developed EON simulator (Appendix 8.4) was extended to support SERANO functionality: (I) 3R regeneration; (II) selectable modulation format and (III) tunability of central carrier frequency. In addition, a number of SERANO related RMSA algorithms were implemented and evaluated into the developed EON Simulator. The proposed RMSA algorithms focus on the optimization of path split problem and BVT placement problem, while for the remaining steps of the RMSA scheme, widely accepted solutions can be adopted. The selection of optimization of these two steps is driven by two motivations: a)

SERANO capabilities can be fully exploited by the path split approach, because in this case the spectrum efficiency can be drastically increased because of the relaxation of the continuity constraint and the optimum selection of modulation format; b) the adoption of such a modular approach has the strength that can be potentially incorporated in any RMSA algorithm proposed in literature.

6.3.2.2 Path Split algorithms

A Path Split algorithm is defined as an algorithmic procedure which split a path P from a node S (source) to a node D (destination) into two or more consecutive paths by using a set of criteria. A Path Split algorithm provides as outcome a set of path split solutions for the selected initial path. Four path splits algorithms are presented in brief below.

The HighMFFirst algorithm applies splits into the initial path in such a fashion in order the highest feasible modulation formats to be assigned in all the generated consecutive paths. The main objective of the algorithm is the maximization of spectral efficiency by the use of the highest available modulation formats (if attainable) for the largest part of the request paths and for the highest proportion of the incoming requests. The functionality of the HighMFFirst algorithm is depicted graphically in Figure 19(a). In this example, the HighMFFirst algorithm splits the initial path 1-2-3-4-6-7-8 into three different paths 1-2-3, 3-4-6 and 6-7-8 respectively with smaller path distance each (assuming 250Km each). For each path a higher modulation format is assigned and therefore the spectral efficiency is doubled (we need half of the initial frequency slot units –FSUs- per edge) at the expense of two SERANO modules (yellow blocks).

The UtilBasedSplit algorithm applies splits in the initial path based on the utilization of the links across the initial path. The main objective of the algorithm is the relaxation of the frequency continuity constrain near (before or after) edges with high utilization aiming to minimize the number of FSUs assigned in highly utilized links. The functionality of the UtilBasedSplit algorithm is depicted graphically in Figure 19(b). In this example, we assume that edge 6-7 is highly utilized and can accommodate only 10 sequential FSUs. The UtilBasedSplit algorithm splits the initial path into two different paths 1-2-4-6 and 6-7-8 with smaller path distance each (assuming 500Km and 250Km respectively). For each path a higher modulation format is assigned and therefore the spectral efficiency is improved resulting to a not blocking situation.

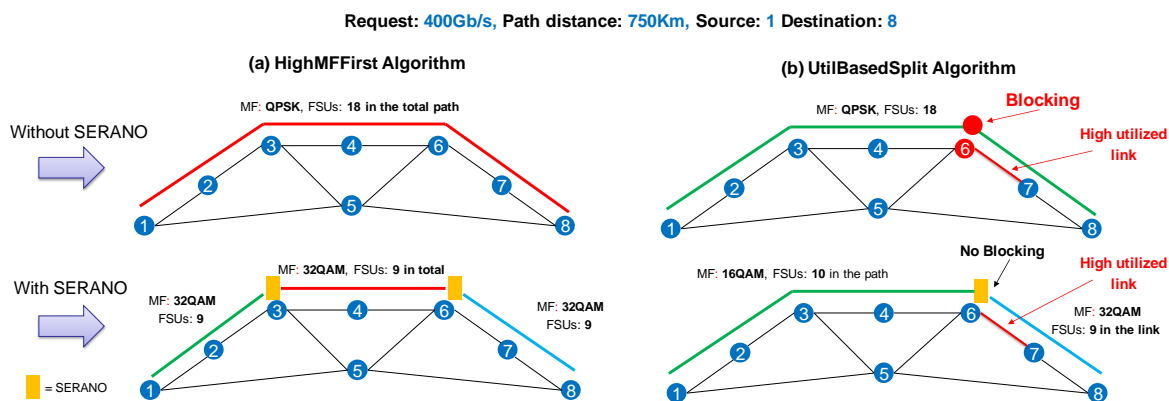

Figure 19: Example of HighMFFirst and UtilBasedSplit algorithms.

In addition, two path split algorithms (CombUtilFirst and CombMFFirst) are designed which combine the functionality of the algorithms presented below to achieve maximum gains

from the exploitation of SERANO advantages. The CombUtilFirst algorithm combines the solutions of the two previous algorithms, while during the final classification of the solutions, priority is given to splits offering high utilization, while the CombMFFirst gives priority to splits allowing for the high modulation format selection.

6.3.2.3 BVT Placement algorithms

A BVT Placement algorithm is defined as an algorithmic procedure which allocates BVTs - which are the basic building blocks of SERANO architecture- into the network. The BVT placement algorithm is executed during the offline phase of the network, therefore it is a dimensioning algorithm. The outcome of the algorithm determines the number of BVTs that should be placed in each $\{Node, Input, Output\}$ triplet of the optical network. The outcome of the BVT placement algorithm is of major importance because it estimates the total number of BVTs that should be allocated in the network, which directly affects the extra cost (CapEx/OpEx) of the SERANO nodes.

Two BVT Placement algorithms are proposed. The first one (EqualDistrib) allocates all available BVTs equally on all nodes and I/O pairs. Therefore the same number of BVTs are allocated per (Node,Input,Output) triplet of the network. The second one (PropShortestPath) allocates BVTs proportionally to the number of appearance of $\{Node, Input, Output\}$ triplet in the estimated shortest paths. For example, if a triplet $\{N_1, I_1, O_1\}$ participates in A shortest paths (assuming all shortest paths from every source node to any destination node in the network), while a triplet $\{N_2, I_2, O_2\}$ participates in B shortest paths, then the algorithm will allocate x BVTs on triplet $\{N_1, I_1, O_1\}$ and y BVTs on triplet $\{N_2, I_2, O_2\}$, where $y = x * B / A$.

6.3.2.4 RMSA algorithm performance evaluation

A set of simulation scenarios were created, implemented and executed using the developed EON Simulation tool (Appendix 8.4), in order to estimate the gains by the adoption of RMSA algorithms exploiting SERANO capabilities. Regarding the simulation configuration, four modulation formats were available: DP-QPSK, DP-16QAM, DP-32QAM and DP-64QAM with a maximum reach of 2000Km, 496Km, 271Km and 151Km respectively, while three request demand rates were available: 100Gbit/s, 200Gbit/s and 400Gbit/s. Regarding the physical configuration, a baud rate of 26Gbaud was selected, with a grid step of 6.25GHz, assuming 320 FSUs per fiber and selecting a guard band of 2 FSUs. Regarding the network topology, the BT network comprised of 103 nodes and 164 edges was used, assuming one fiber per edge.

As far as traffic generation is concerned, new requests (flows) arrive in the network following a Poisson distribution, while the request's service time is exponentially distributed. For each request, the source and destination node are uniformly selected among the available nodes, while the request demands are uniformly distributed in the set (100G, 200G, 400G). All requests are bidirectional with equal demands on both directions.

Regarding the BVT counting scheme, we assumed that in a SERANO block and for an I/O fibre pair, each BVT can handle one 100G flow per direction. In all scenarios, the Yens algorithm ($k=5$) was used for the estimation of k shortest paths, while the First Fit algorithm was adopted for the spectrum assignment. For the modulation format selection we used a Best Fit algorithm which selects the highest possible modulation format. Apart from the scenarios that include support for SERANO functionalities, two "references" scenarios were defined. Scenario BVT0, simulates the reference case in which there are no SERANO nodes in the network. Scenario BVT-INF simulates the ideal case in which an

infinite number of BVTs are available and therefore the spectrum continuity constraint can be ignored.

In order for the proposed RMSA algorithms (Path Split algorithms and BVT Placement algorithms) to be evaluated in terms of performance, three sets of simulation scenarios were created and executed. In the first set, the performance of the most efficient path split algorithm (CombUtilFirst - CUTF) was evaluated, assuming equal distribution of BVTs on each node and I/O pair (EqualDistrib). In the second set, the performance of CombUtilFirst algorithm was evaluated by using the more efficient BVT placement algorithm (PropShortestPath), while in the third scenario all the proposed path split algorithms were evaluated and compared, assuming the PropShortestPath BVT placement algorithm.

The results of the performance evaluation are depicted in Figure 20.

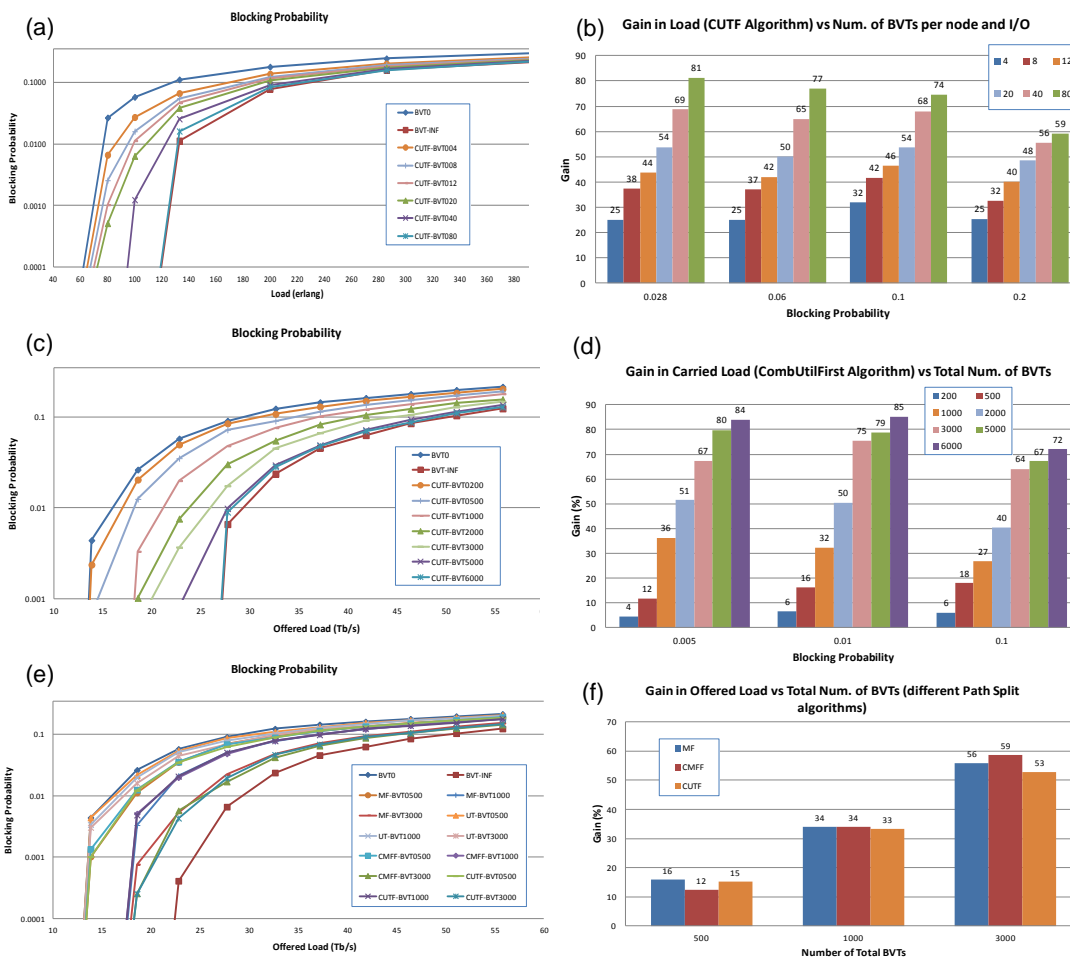

Figure 20: Blocking probability (a),(c),(e) and gain in load (b),(d),(f) for three simulation scenario sets.

For the first set, the results in terms of blocking probability are illustrated in Figure 20(a), in which scenarios are denoted with CUTF-BVTXXX, where XXX is the *number of BVTs per (node,I,O) triplet*. It is obvious that blocking probability values decrease in proportion to the increase of BVTs, while for high number of BVTs we reach close to the ideal situation (BVT-INF). In addition, Figure 20(b) presents the gain in load for different selections of blocking probability values and for different values of BVT number. The gain in load is

calculated by dividing the offered load in a selected scenario with the offered load in the reference BVT0 scenario which causes the same blocking probability with the selected scenario. Figure 20(b) shows that the gain in network load is increasing with the number of BVTs per EON node, spanning from 25% to 81%.

In the second set, Figure 20(c) illustrates the blocking probability results for different values of measured offered load in terms of total capacity in the network (Tb/s). According to the figure, the blocking probability values decrease drastically even for a small number of BVTs. In addition, Figure 20(d) illustrates the gains in terms of carried load for various number of BVTs and for three selected values of blocking probabilities. It is become obvious that in all cases the gain in carried load is increasing with the total number of SERANO BVTs in the network, spanning from 4% to 85%.

In the third set, Figure 20(e) illustrates the results of blocking probability, while Figure 20(f) presents the gains in terms of offered load for different path splits algorithms in comparison to the reference scenario with no SERANO support (BVT0). Regarding blocking probability, similar results are shown for the different algorithms given a total number of BVTs, while blocking probability is highly affected by the number of available BVTs. In addition, in terms of gains, all path splits algorithms present similar gain for a specific number of total available BVTs.

6.3.2.5 Physical layer performance of SERANO nodes

The SERANO node implementation poses some interesting problems in that it has an input stage that need to support a large split ratio while carrying a large number of channels/spectral-slots.

In order to evaluate the physical layer performance, and in particular the potential of this technology to be implemented in the context of an optical node with a large number of fibers and/or spectral slits, we assume that the input stage is implemented using a cascade of splitters with inline amplifiers as shown in Figure 21. Since the input stage needs to be compact, we evaluate the performance assuming the use of Erbium Doped Waveguide Amplifiers (EDWA) [TEEM] potentially integrated in the same package with a splitter (dashed line in the figure). In particular we model two different EDWA versions, one with single pumping and one with double pumping and consequently higher gain/output power.

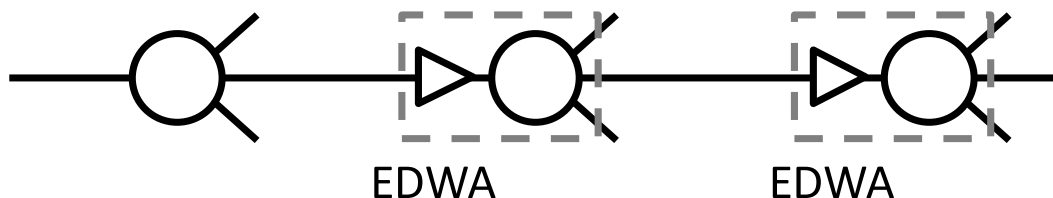

Figure 21: SERANO node input stage.

Using the published specifications of EDWAs [TEEM] we estimate the P_s and G_{ss} of the devices using the formula:

$$G = G_{ss} e^{-(G-1) \frac{P_{in}}{P_s}} \quad (1)$$

and we obtain the values given in Table 6.

Table 6: Calculated EDWA parameters.

	Single pump EDWA	Double pump EDWA
P_s	1.63 mW	5.36 mW
G_{ss}	11.9	9594.2
NF	7 dB	7 dB

In order for the input stage to support the scenarios studied above, a split of up to 1:512 is needed; for other splitting ratios the same methodology is followed. Given the EDWA gain limitations, it is reasonable to assume an optical coupler in the EDWA splitter up to 1:8. To attain the requested overall splitting, a scheme with cascading stages of EDWAs is assumed. In particular, the configurations we study here comprise a 1:8 splitter and then 2 1:8 splitters or three 1:4 splitter stages with EDWAs between them.

Given the limited output power of the EDWA devices, it is important to ensure that an adequate output power is provided. Of concern is that this output power should be above the BV Rx sensitivity for the following SERANO stage. Since this depends on the adopted modulation format and baud-rate, the number of EDWA cascading stages has to be scaled for the maximum capacity case: the higher the number of EDWA stages (and/or the lower the splitting a single EDWA is offering) the higher the output power per channel would be. For the analysis here we assume that the power is split among 80 signals, which is pretty much a worst case assumption under both a 5GHz fixed grid and an elastic grid.

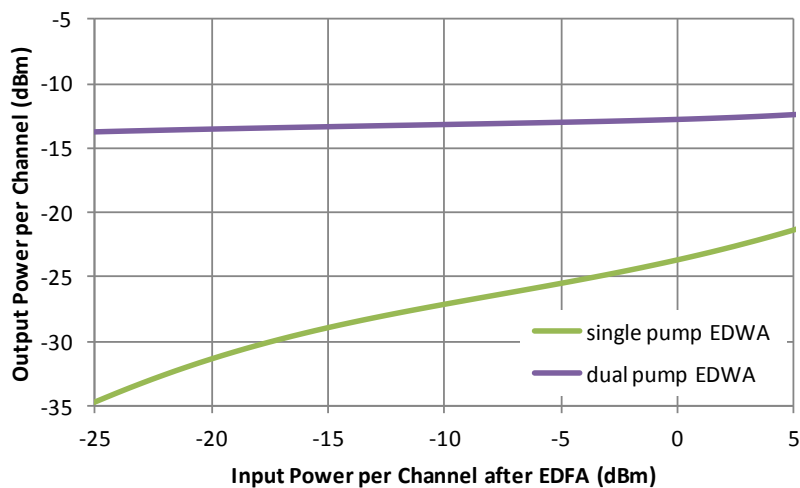

Figure 22: Output power per channel as a function of the input power per channel using 2 EDWA stages (1:8 splitters).

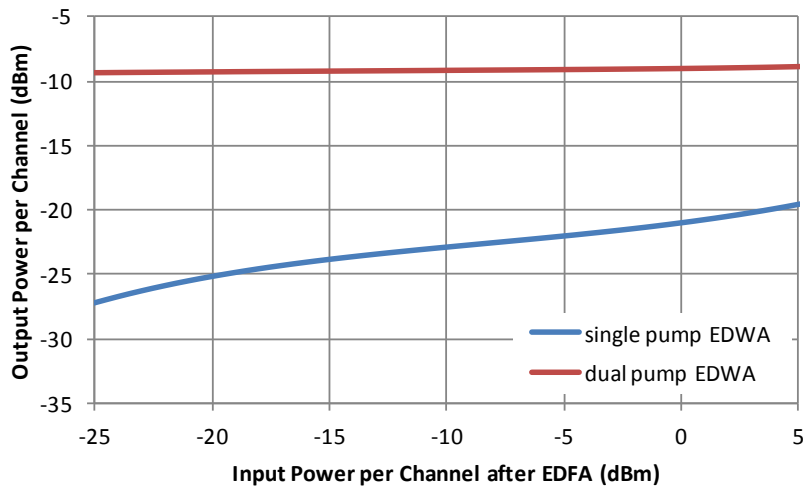

Figure 23: Output power per channel as a function of the input power per channel using 2 EDWA stages (1:4 splitters).

In Figure 22 and Figure 23, we calculate the output power of the EDWA as a function of the input power per channel. We see that in a two amplifier configuration with single pumping in the EDWAs it would be hard to achieve output power above the receiver sensitivity of the S-BVT, while with double pump EDWAs there shouldn't be a problem. As expected, the scenario with 3 EDWA stages (and 1:4 splitting) is able to maintain higher output power per channel but again the output power per channel when using single pump EDWAs is probably below the S-BVT receiver sensitivity.

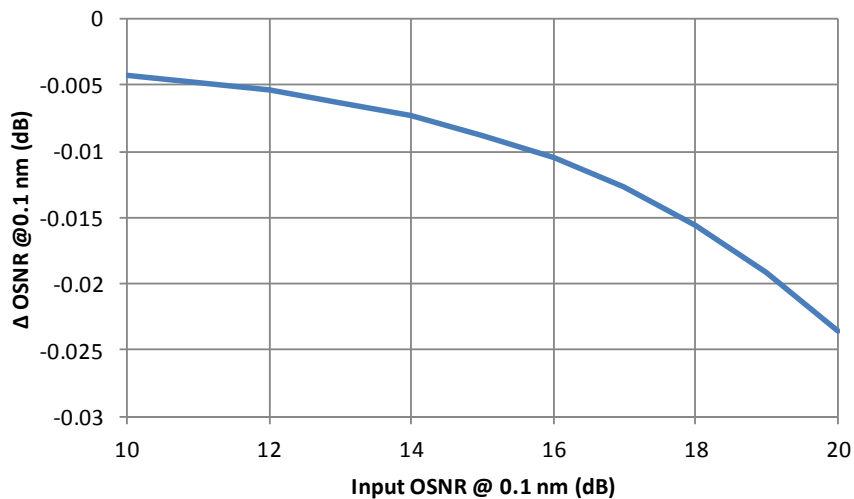

Figure 24: Δ OSNR as a function of input OSNR.

Finally, Figure 24 shows the worst case deterioration of OSNR through the SERANO input stage as a function of input OSNR among all scenarios investigated. This is obtained when two EDWA stages are used (with 1:8 splitting) and with the single pump EDWA. As expected, the OSNR deterioration is negligible for all values of input OSNR.

6.3.3 Defragmentation

The defragmentation technique named “push-pull” has been proposed and demonstrated within IDEALIST. In particular, the signal can be shifted in the frequency domain without loss of data, thus hitless. This can be achieved thanks to an automatic frequency control (AFC) at the receiver. AFC is typically implemented in coherent receivers to track and compensate possible laser drifts. In this case it is exploited to follow larger shifts to defragment the spectrum. Push-pull can be done in EONs thanks to bandwidth-variable BV-WSSs, as shown in Figure 25.

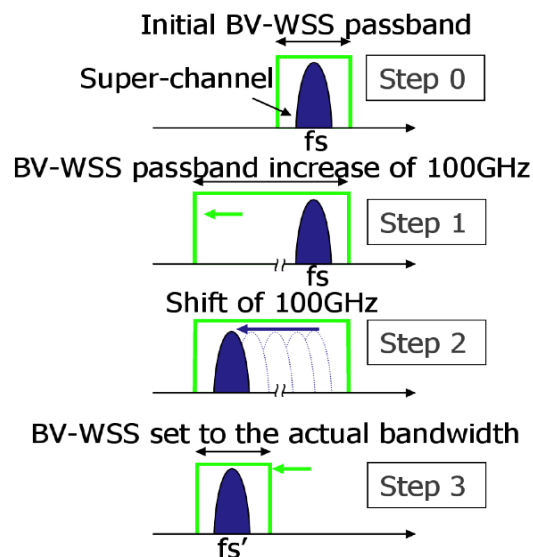

Figure 25: Filters enabling push-pull.

At STEP 0 defragmentation is triggered; at STEP 1 all the filters traversed by the connection are enlarged to enable the frequency shift without cutting the signal; at STEP 2 frequency shift is performed according to push-pull; at STEP 3 the filter is re-closed to the actual bandwidth.

In [Sambo-JOCN13] push-pull for super-channel is demonstrated. In the case of super-channel, the frequency shift may not be trivial. The reason lies in how a super-channel can be created. Indeed, sub-carriers can be generated through an array of lasers. If the push-pull is performed by tuning each laser central frequency, lasers should synchronously move to avoid sub-carrier overlapping. This operation is not trivial. Moreover, the resolution and the stability of the lasers can likely cause overlapping among adjacent subcarriers during the frequency shift. Such problems have been overcome in [Sambo-JOCN13] thanks to the adoption of a periodically poled lithium niobate (PPLN) waveguide. A solid shift of all the sub-carriers without incurring detrimental sub-carrier overlapping has been demonstrated. No synchronous shift of all the lasers generating the subcarriers is required. The only shift of a laser pump inside the PPLN implies the solid shift of the whole super-channel. For more details the reader can refer to [Sambo-JOCN13].



6.4 Long term solutions for the Internal Control and Monitoring

Advanced control/monitoring capabilities (e.g., enabled by S-BVT based on TFP, see section 4.4) have been exploited within IDEALIST for recovery purposes [Cugini-JOCN15]. In this work, advanced DSP with monitoring functionality is used. Whenever specific events occur, these monitoring functionalities trigger a new hitless dynamic adaptation technique operating on the applied LDPC code. The technique has been successfully demonstrated to increase transmission robustness upon failures caused by impairment degradation (e.g. amplifier malfunction). Finally no traffic disruption is experienced.

The use of code adaptation enabled the service to be recovered in just a few ms. With respect to modulation format adaptation, code adaptation is particularly efficient because it guarantees hitless recovery, while modulation format adaptation is not hitless and requires a transponder supporting multiple formats (i.e., a DAC is typically mandatory). Moreover, code adaptation does not necessarily require BV-WSSs to reconfigure which is time consuming, indeed current commercial BV-WSSs (e.g., Finisar Waveshapers) represent the bottleneck for a fast recovery requiring seconds for reconfiguration due to proprietary software for programming the passband of the filters. Because of this, the entire protection switching time requires just few ms, given that the protection paths (thus, traversed BV-WSSs) are already set up before service takes place.

Code adaptation leverages the monitoring of the variance of the constellation point spots which is related to the OSNR. In particular, the larger the OSNR is the lower the variance. Thanks to DSP, the variance can be monitored on an active lightpath, thus information on the quality of transmission (OSNR) can be retrieved. In the case of signal degradation during lightpath operation, a possible increase of the variance (e.g., due to amplifier malfunction) falling in a “critical region” (see [IDEALIST-D2.3]) can be detected before the level of BER overtakes the threshold of acceptability. Then, the control plane can automatically set a more robust code without incurring in data loss because of signal degradation.

The effectiveness of code adaptation has been demonstrated on a Tbit/s super-channel.

Another technique for overcoming transmission degradations in DSP-based optical OFDM, is the adaptive modulation of OFDM digital sub-carriers according to an SNR profile. This technique uses a sub-carrier SNR estimation performed at the receiver. With this information, the transmitter computes the optimum bit/power loading of the digital sub-carriers using a suitable algorithm (e.g. Levin-Campello). An example is described in Appendix 8.2, focused on overcoming the optical filter narrowing effect. Interestingly, the sub-carrier SNR at the receiver has a direct relationship to the OSNR per sub-carrier [Fabrega-OptCom15]. So, this last parameter could also be used as an input for computing the optimum bit/power loading of each digital sub-carrier.

In fact, high-resolution optical spectrum analysis can be used for monitoring the OFDM sub-carrier OSNR in a non-intrusive way, i.e. with no data reception/decoding. As optical OFDM has advanced spectrum manipulation capabilities, different optical spectrum portions of the transmitted signal can be set to zero for in-band noise estimation, leading to in-band sub-carrier OSNR monitoring using the same technique [Fabrega-ICTON13]. These methods have been reported and experimentally validated in [Fabrega-ICTON13] [Fabrega-OptCom15], opening the door to live monitoring of these quality parameters at the nodes of the optical networks with no need for demodulating data.



7 Conclusions

This final deliverable from Work Package 2 of the IDEALIST project summarizes the IDEALIST vision regarding data plane technological solutions enabling the introduction of Elastic Optical Networks (EONs) and supporting their gradual evolution.

The document shows that the current state of the market for components and systems enabling EON and the state of maturity of the relevant standards is sufficient to lead to the consolidation and the widespread use of a first EON generation within the next few years.

To avoid the risk of multiple EON transponder designs (a similar situation to the “modulation format soup” which has “killed” 40G data-rate), IDEALIST is proposing a concrete solution including a limited set of options ready to be implemented in a short time frame. An essential part of this solution is the introduction of BVTs with an up to 400Gbit/s net capacity.

In 2021 and beyond, building on top of these first generation systems, a sustainable capacity upgrade will be made possible by technological enhancement in footprint and power consumption: more capacity will be available on the same shelf.

In terms of functionalities and optical performance, the “second generation” (S)-BVT will implement new and more efficient ASICs for enhanced, but less power hungry, DSPs enabling new S-BVTs with 1Tbit/s or more net capacity.

An effective technological breakthrough is expected to take place only when the traditional node architecture will be no longer able to support the traffic increase: BV-WSS based ROADM have a limited number of optical ports and thus cannot support more than a maximum number of transmission links at the same time.

If this limit is exceeded, innovative node architectures have to replace the conventional ROADM architecture. IDEALIST in the long term vision is proposing the flexible Architecture on Demand (AoD) paradigm as an interesting candidate. Advanced techniques (possibly all optical) for traffic engineering, defragmentation and super-channel regeneration will find a place as specific functional modules to be added when and where they are needed.

8 Appendix

8.1 Sub-carrier generation module power consumption evaluation in BVT design

The S-BVT design can be further optimized by using low cost and low power consumption pluggable line card modules, realized with silicon photonics technology. To lower the cost and power of the photonic pluggable modules of the S-BVT, designed in Figure 9, the light source can be removed from the package and a single multi-wavelength light source can be integrated on board and shared among all modules. The light source can be connected with the pluggable modules throughout via waveguides with passive aligned optical connectors placed in the printed circuit board.

The cost and power saving of this solution strongly depends on the design [D'Errico-OFC16]. Two design alternatives are possible: an array of N different DFB lasers, for instance monolithically integrated lasers on a single die (e.g. in III-V materials); a multi-wavelength locked laser source [Sambo-JOCN14].

If N discrete lasers tunable in the C-band (ITU-T G.698.2) are used, there can be no limitation to the S-BVT sliceable operation, to the expense of having N different thermal stabilizers, one per active laser. In this case the power consumption can range from 2W to 4W per laser, in the case of a DFB laser stabilized with proper wavelength locker circuitry, depending on the required lasing wavelength stability and optical launched power. In the case of $N=10$, overall power consumption can be 40W (corresponding to around 15% of the maximum power consumption estimated in Section 4.7).

An alternative to integrating lasers on a single die would be to take advantage of a common thermal stabilizer. Depending on the process yield and volumes, the power consumption can be around 50% lower than the discrete DFB lasers.

The latter solution based on multi-wavelength source has some advantages. Costs and power consumption can be reduced given that for N generated sub-carriers, $N-1$ lasers are saved. Furthermore, subcarrier wavelengths are relatively fixed and the generated mutual-crosstalk among sub-carriers can be counteracted with reduced complexity of the signal processing. Another advantage can be the simpler way for light source setting parameters. For instance, the central lasing wavelength and the wavelength spacing determine the monitoring operation of the transponder allocation of super-channels in the available optical spectrum. Referencing to the solution proposed in [Sambo-JOCN14], 5W can be evaluated (corresponding to around 2% of the maximum power consumption estimated in Section 4.7). As a drawback, the multi-wavelength solution may present limitations allocating sub-carriers in the spectrum [Sambo-JOCN14]. Actually in terms of network cost the multi-wavelength source advantages can be very limited as the limited flexibility in the allocation of resources can have a non-negligible impact.

In Figure 26 graphs are reported outlining the different power consumption obtainable with the three designed options for the sub-carrier generation module: discrete lasers on board of the line card, i.e. DFB lasers; monolithically integrated lasers in III-V material, i.e. Indium-phosphide; multi-wavelength, MW, source realized with a single laser as in [Sambo-JOCN2014]. The MW solution is the best performing but with the expense of reduced network flexibility, while the monolithic integrated array of lasers is ensuring the highest network flexibility, with fast time to market with still good performing power consumption. The discrete solution presents the highest power consumption but can have the advantage

to switch ON lasers only when needed to improve transmission capacity once an optical module is plugged in the S-BVT.

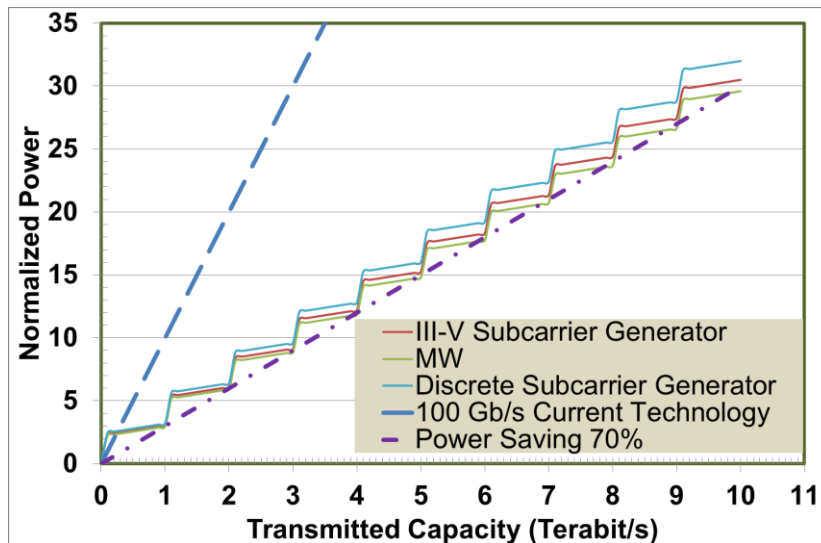

Figure 26: Power Consumption curves for three design options of the subcarrier generation module: discrete lasers on board of the line card, i.e. DFB lasers; monolithically integrated lasers in III-V material, i.e. Indium-phosphide; multi-wavelength, MW, source realized starting from a single laser as in [Sambo-JOCN2014].

8.2 Data plane alternatives based on sliceable transceivers for optical aggregation networks

The work reported in this section is carried out to complement the concepts described in Section 5, leveraging the work reported in [Fabrega-ICTON15]. So, the main goal is to compare the performance of standard IM/DD OOK and SSB DD-OFDM in the specific case of flexgrid optical aggregation networks. Thus, these two candidates are considered taking into account the trade-off between cost and flexibility.

As this use case envisions a high density of low bitrate connections, the optical filters used should feature also small bandwidth (e.g. 12.5GHz when establishing connections at 10 Gbit/s). When cascading these narrow bandwidth filters, the bandwidth of the resulting optical path is substantially decreased and distorted due to the smooth transition band of the filters employed.

Please note that the IM/DD OOK system operates at a fixed 10Gbit/s data rate, with no digital signal processing (DSP) and legacy hardware. Along a different line, the OFDM transceiver is a low cost future-proven solution including DSP, approaching the bandwidth variable transceiver (BVT) concept. One of the relevant OFDM abilities is that its individual sub-carriers can be arbitrarily set with different bit/power loads, enabling optical spectrum manipulation with sub-wavelength granularity. This is an interesting aspect, as it enables the possibility of adaptively modulating each OFDM sub-carrier according to the measured SNR profile per sub-carrier, either at the receiver side or employing advanced monitoring techniques as reported in Section 6.4. Furthermore, several forward error correction (FEC) code options can be used ad hoc in the SSB OFDM BVT, according to the target

performance and the available resources. Additionally, no dispersion compensation is needed by the OFDM transceiver proposed, at the expense of including an SSB filter at the transmitter side; whereas OOK is heavily affected by the chromatic dispersion, needing compensation modules at the nodes.

The performance of the proposed system is assessed by means of numerical simulation using Matlab and Numeric Python software. Both approaches have been evaluated by means of Monte Carlo error counting, which provides the best estimation of the system bit error ratio (BER). In both cases, a target BER limit is set to 10^{-3} , assuming a hard decision FEC (HD-FEC) coding scheme. Further details of the simulation parameters can be found in [Fabrega-ICTON15].

For the OFDM system, the performance is additionally evaluated in case of performing bit loading using the Levin-Campello margin adaptive algorithm as in [Nadal-JLT14].

The performance of the proposed systems is assessed in terms of back-to-back OSNR requirement within 0.1nm. Since typical reconfigurable node architectures consider two filtering stages when performing a pass-through/drop/add operation, we carry out the study considering the concatenation of up to 12 filters (considering 6 hops). The filters are considered to have nominal bandwidth of 50GHz, 25GHz and 12.5GHz. Results are shown in Figure 27.

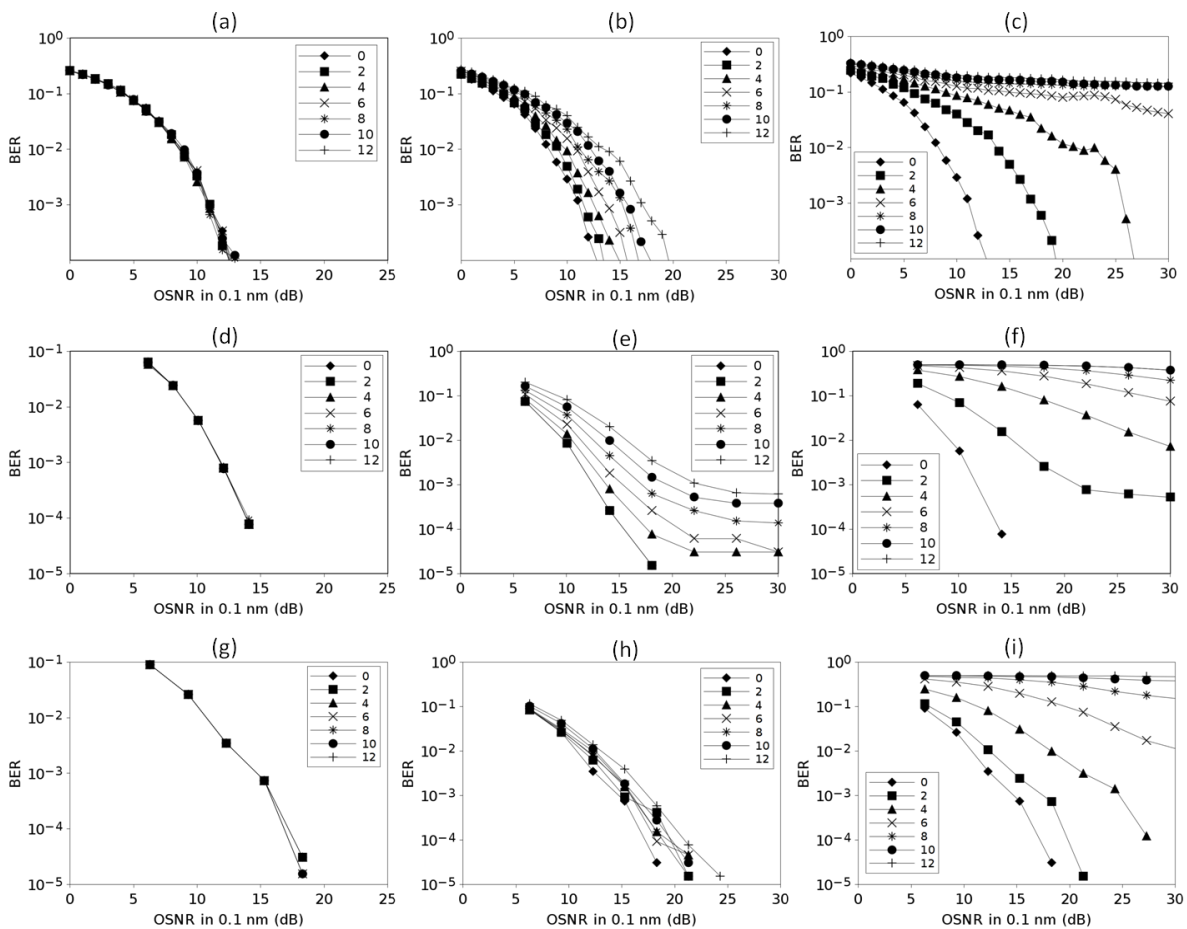

Figure 27: Simulation results for a standard IM/DD system (a, b, c), the OFDM SSB transceiver without bit loading (d, e, f) and with bit loading (g, h, i) after concatenation of different filters featuring bandwidths of 50 GHz (a, d, g), 25 GHz (b, e, h) and 12.5 GHz (c, f, i).

The 50GHz case is depicted in Figure 27(a), (d) and (g) for OOK and OFDM. Neither the OOK nor the OFDM signals are affected by the filter narrowing effect. The required OSNR for the HD-FEC target BER is 10.7dB for OOK and 12.0dB for OFDM at all the filter stages examined. In case of using bit loading, the performance of OFDM is slightly decreased, requiring 15.0dB OSNR.

When considering 25GHz filters, the required OSNR ranges from 10.7dB up to 17.2dB for the OOK case, whereas the OFDM system needs OSNR values within 12.0dB and 22.7dB to achieve the HD-FEC target BER. In case bit loading is used in OFDM, the OSNR requirement is relaxed to the range between 15.0dB and 17.6dB.

Finally, the case of filters with 12.5GHz is analyzed. As expected this is the worst examined case. Indeed, OOK can only meet the HD-FEC target BER after 2 and 4 filtering stages, with 17.2dB and 25.7dB OSNR, respectively. For the OFDM system, similar degradation is observed and it meets the proposed HD-FEC target BER after 2 filtering stages with 21.5dB OSNR. In case bit loading is used, OFDM can be suitable for 2 and 4 filtering stages requiring 17.6dB and 24.9dB OSNR, respectively.

In summary, we have examined two alternative solutions for sliceable transceivers in the context of flexgrid optical aggregation networks. Potential candidates include legacy 10G OOK and SSB OFDM technologies, trading cost against flexibility. Optical filter narrowing effect has been investigated for the proposed technologies assuming narrow bandwidth connections. Results show that OFDM BVT is a feasible candidate, providing increased flexibility, thanks to its ability to set different performance target when taking into account the filter narrowing effect.

8.3 Results on flexibility measurements

Figure 28(a) shows a comparison of the measured flexibility between different port dimensions of the WSS and SSS (BV-WSS) across a certain number of wavelength channels. The flexibility of the SSS for all cases was calculated with a spectral granularity of 12.5GHz. It is also clear that the increase of the number of wavelengths affect more the SSS than the WSS and critically more impactful on high dimension switches.

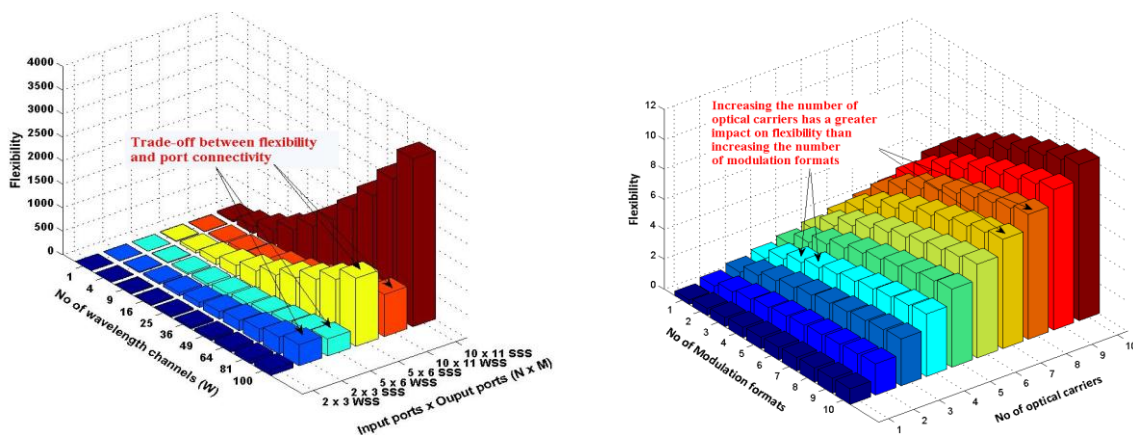

(a) Comparison WSS and BV-WSS

(b) Comparison of modulation formats and optical carriers

Figure 28: Comparison of measured flexibility for WSSs/SSSs (BV-WSSs) and BVTs.

However, it should be noted that there is a trade-off between flexibility and port connectivity as indicated in Figure 28(a); the 5x6 SSS has greater flexibility than the 10x11 WSS but lower port connectivity. The same trade-off exists between the 2x3 SSS and the 5x6 WSS. Therefore, such results directly feed to a more informed design of a ROADM based on different levels of flexibility and connectivity required. Figure 28(b) illustrates a comparison between the modulation format number and the number of optical carriers while other parameters are kept constant. It is noted in Figure 28 that an increase in the number of optical carriers has a greater impact than an increase in the number of modulation formats. Table 7 list different transmitter configurations.

Table 7: Different transmitter configurations.

Tx-er Config.	No of Optical Carriers	Laser Type	Program. Mod. formats	Program. symbol rate (Gbd)	Max. Capac (Gb/s)	Max. SE (bits/s/Hz)	Min. Granular (Gb/s)
Config. 1	1	1 tunable-laser (80 C-Band Channels)	BPSK, QPSK, 8PSK, 16QAM, 32QAM and 64QAM	10, 14, 18, 22, 26 and 30	180	3.6	10
Config. 2	5 optical carriers	5 Non-tunable lasers	fixed modulation format QPSK per carrier	fixed symbol rate of 30 per carrier	300	1.2	60
Config. 3	2 optical carriers	2 Non-tunable lasers	fixed modulation format 128 QAM per carrier	fixed symbol rate of 120 per carrier	1680	5.6	840
Config. 4	10 optical carriers	10 Non-tunable laser	Each carrier supports BPSK, QPSK, 8PSK and 16QAM	Each carrier supports 10, 14, 18, 22, 26 and 30	1200	2.4	10

The connectivity of the optical transmitter is represented by the number of optical carriers that can be transported to different destinations. Figure 29 shows a comparison of the four transmitter configurations listed in Table 7.

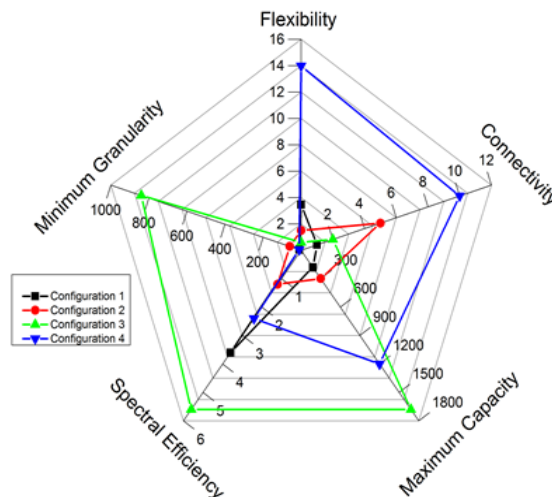

Figure 29: Comparison of different configurations of transmitters.

It can be noted that trade-offs exist between flexibility, connectivity and capacity. Configuration 3 is the least flexible but has the highest maximum capacity. Configuration 4 has the highest flexibility and connectivity but has a lower maximum capacity than configuration 3. Configuration 1 has a higher flexibility than configuration 2 and 3 but lower connectivity and maximum capacity. Configuration 2 has a higher maximum capacity than configuration 1 but a lower spectral efficiency.

The flexibility formulas for the different devices are included in Table 8.

Table 8: Flexibility formulas for key optical devices of ROADMs.

Optical device	Flexibility
$N \times M$ WSS	$F(S) = W \log \left(\sum_{a=0}^x \frac{M!}{(M-a)!} \binom{N}{N-a} \right)$ if $N \leq M, x = N$ and if $N > M, x = M$
$N \times M$ SSS	$F(S) = kW \log \left(\sum_{a=0}^x \frac{M!}{(M-a)!} \binom{N}{N-a} \right)$ if $N \leq M, x = N$ and if $N > M, x = M$
Optical transmitter	$F(S) = \log \left(\sum_{a=0}^N \left(\sum_{s=1}^s ((BE)^s) W \right)^a \binom{N}{N-a} \right)$
Optical transmitter with flexible grid on different centre frequencies	$F(S) = \log \left(\sum_{a=0}^N \left(\sum_{s=1}^s ((BE)^s) kW \right)^a \binom{N}{N-a} \right)$

Subsystem Flexibility

The flexibility of a subsystem can be quantitatively measured considering maximum entropy of system, additionally if two optical components with flexibilities F_a and F_b form a subsystem, the resultant flexibility F_{ab} satisfies the following relation:

$$F_{ab} \leq F_a + F_b$$

The resultant flexibility F_{ab} is only equal to the sum of the individual flexibility of the components if F_a and F_b subsystems are disjoint i.e. the working principle of each component does not depend on the other. Table 9 lists the proposed flexibility models of key subsystems designs.

Table 9: Models for measuring flexibility of subsystems.

Optical Subsystem	Flexibility models for subsystems
N BVTs + $N \times M$ WSS	$F(S) = \log \left(\sum_{c=1}^N \left(\sum_{a=1}^d \left(\left(\sum_{s=1}^s (BE)^s \right)^c \right)^a \frac{W!}{(W-a)!} \binom{d}{d-a} \left(\sum_{i=0}^x \frac{M!}{(M-i)!} \binom{c}{c-i} \right)^a \binom{N}{N-c} \right) + 1 \right)$
N BVTs + $N \times M$ MCS	$F(S) = \log \left(\sum_{c=1}^N \left(\sum_{a=1}^d \left(\left(\sum_{s=1}^s (BE)^s \right)^c \right)^a \frac{W!}{(W-a)!} \binom{d}{d-a} \left(\sum_{i=0}^x \frac{M!}{(M-i)!} \binom{c}{c-i} \right)^a \binom{N}{N-c} \right) + 1 \right)$
N BVTs + $N \times M$ SSS	$F(S) = \log \left(\sum_{c=1}^N \left(\sum_{a=1}^d \left(\left(\sum_{s=1}^s (BE)^s \right)^c \right)^a \frac{kW!}{(kW-a)!} \binom{d}{d-a} \left(\sum_{i=0}^x \frac{M!}{(M-i)!} \binom{c}{c-i} \right)^a \binom{N}{N-c} \right) + 1 \right)$

For all subsystems W or $kW \geq d$ and if $c \leq N$ $x = c$, else $x = M$

For the N BVT + $N \times M$ WSS, we assume that the BVT (actually an S-BVT) can attain different degrees of flexibility by varying transmission parameters; modulation format, symbol rate, number of tuneable wavelength channels, electrical subcarriers and optical carriers. We assume N is the number of BVTs, c is the number of BVTs transmitting at a time, and therefore c is the number of active input ports on the WSS. $(N-c)$ is the number

of BVTs that are off, therefore $(N-c)$ is equal to the number of inactive input ports of the WSS. For each BVT, we assume that d is equal to the number of optical carriers, a is equal to number of optical carriers that are transmitted at a time, $d-a$ is equal to the number of optical carriers that are off. s is equal to the number of electrical sub-carriers, B is equal to the number of programmable modulation formats, E is equal to the number of programmable symbol rates, W is equal to number of tunable wavelength channels. For the $N \times M$ WSS, i is equal to the number of same wavelength channels than can be successfully passed at a time, $c-i$ is equal to the number of same wavelength channels that are blocked and x is the maximum number of a single wavelength that can be passed. The N BVT + MCS is and N BVT + $N \times M$ SSS are derived in following a similar procedure.

Figure 30 illustrates the measured flexibility of different subsystems designs with the same configurations. The flexibility of each subsystem configuration is measured by varying the number of optical carriers while other parameters are kept constant. We notice that increasing the number of optical carriers impacts the flexibility of the 4 BVT + 4x16 WSS more than the 4 BVT + 4x16 MCS and this is attributed to the fact that the 4 BVT + 4x16 WSS provides space and spectrum switching functions i.e. slicing of optical channels across different output ports while the 4 BVT + 4x16 MCS only provides space switching functions. Increasing the optical carriers has the greatest impact on the 4 BVT + 4x16 SSS due to finer spectral granularity.

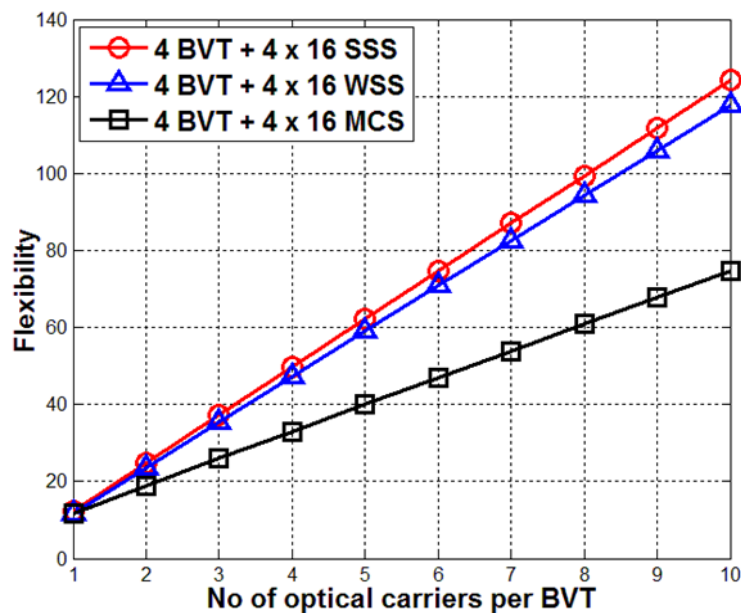

Figure 30: Comparison of different subsystem with same configuration ($B=5$, $E=5$ and $W=30$).

8.4 Discrete Event Simulator for EON demonstrating the impact of SERANO

The emergence of EONs makes the typical optical networks more flexible by improving spectral efficiency and allowing dynamic adaptation to traffic volume changes. In order to effectively forecast the gains from the adoption of EON architecture, while in parallel minimize CapEx/OpEx expenditures, new simulation environments should be developed which will provide the means and the appropriate tools for the detailed evaluation and



performance analysis of the emerging EON architectures, mechanisms, protocols and algorithms.

Currently, the performance of newly proposed EON algorithms/mechanisms/ protocols are evaluated on general purposed simulation tools (e.g. Matlab, OPNET, NS2). Because of their generality, these frameworks are not sufficient for EON evaluation studies and therefore either the derived performance results have a low level of accuracy or in the best case in order the result accuracy to be improved, significant effort is needed from the researchers in order the EON functionalities to be modeled satisfactorily in the simulation environment. Another significant limitation of currently available simulation environments is their low level of simulation execution automation. In practice an initial simulation scenario is executed a high number of times with similar parameter values, resulting to a high number of simulations scenarios which currently should be executed manually or with a low level of automation.

Because of the limitations of the current available simulation tools described above, a development of a new simulation environment customized to the characteristics of the EON networks is vital. In this direction, we design, specify and implement a new simulation environment which provides the appropriate tools for the detailed performance evaluation of EON algorithms/mechanisms/protocols, while the modeling, parameterization and performance evaluation parts of the simulation environment are fine tuned to the EON characteristic.

The developed EON simulation tool is based on a Discreet Event Simulator (DES) kernel which is responsible for the handling, prioritization and execution of the simulation events, generated and scheduled during the simulation execution runtime. The developed EON simulation tool is implemented in Java. The DES kernel is implemented from the scratch, while the mathematic part (e.g. mathematic distributions, pseudo random generation sources) is implemented based on the Apache Commons Mathematics Library [Apache]. The EON idiosyncrasies were taken into consideration in all phases (requirement analysis, specification, definition, design and implementation) of EON Simulator development, therefore the produced simulation solution is highly customized to the characteristics of EON architecture.

In detail, the main characteristics supported by the EON simulation tool are: a) a Frequency Spectral Unit (FSU) Grid [Gestrel-ComMag12]; b) Optical Routing, Modulation format, Frequency and Spectrum Assignment (RMFSA) algorithms; c) Spectrum continuity constrains; d) Spectrum contiguity constrains; e) Path continuity constrains; f) SERANO functionality. The developed EON simulation environment adopt a hierarchical model for the creation, modification and execution of simulation scenarios, which disintegrate information into different levels, while the EON simulation environment can be parameterized by the users through the definition and modification of one basic file, called the Configuration file. In addition, the developed EON simulation tool provides a flexible way for statistic collection, by defining in the Statistic Collection file, the statistic parameters for which the simulation engine will collect values as well as the collection mode. During the design and implementation phase of the EON Simulation tool, special attention has been given to the extensibility of the produced simulation environment, therefore users/developers can both implement easily new algorithms/mechanisms as well as evaluate quickly their performance.