



## Deliverable D6.2

# Initial report on horizontal topics, first results and 5G system concept

<b>Project Number:</b>	ICT-317669
<b>Project Name:</b>	Mobile and wireless communications Enablers for the Twenty-twenty Information Society

<b>Document Number:</b>	ICT-317669-METIS/D6.2
<b>Document Title:</b>	Initial report on horizontal topics, first results and 5G system concept
<b>Editors:</b>	Geneviève Mange (Alcatel-Lucent Bell Labs), Mikael Fallgren (Ericsson AB)
<b>Authors:</b>	Petar Popovski (Aalborg University), Volker Braun, Geneviève Mange (Alcatel-Lucent Bell Labs), Peter Fertl, David Gozálvez-Serrano (BMW Group), Nico Bayer, Heinz Droste, Andreas Roos, Gerd Zimmermann (Deutsche Telekom AG), Mikael Fallgren, Andreas Höglund, Hugo Tullberg (Ericsson AB), Sébastien Jeux (France Telecom - Orange), Ömer Bulakci, Josef Eichinger (Huawei ERC), Zexian Li (Nokia), Patrick Marsch, Krystian Pawlak (Nokia Solutions and Networks), Mauro Boldi (Telecom Italia), Jose F. Monserrat (Universitat Politècnica de València)
<b>Dissemination Level:</b>	PU
<b>Contractual Date of Delivery:</b>	01/04/2014
<b>Status:</b>	Final
<b>Version:</b>	
<b>File Name:</b>	METIS_D6.2 final.docx

**Abstract:**

The overall purpose of METIS is developing a 5G system concept to fulfil the requirements of the beyond-2020 connected information society and to extend today's wireless communication systems for new usage scenarios. A first view on the overall METIS 5G system concept is presented. To facilitate the development of the system concept, METIS uses Horizontal Topics (HTs), each addressing a key new challenge and identifying new functionalities. This deliverable describes the METIS HTs: Direct Device-to-Device Communication, Massive Machine Communication, Moving Networks, Ultra-Dense Networks, and Ultra-Reliable Communication. For each HT, a specific concept is presented which is built on integration of relevant Technology Components (TeCs) researched by METIS. The specific HT concepts and the supporting system architecture are to be integrated into the overall system concept. Demonstrations to be implemented on the METIS test-beds are described. The next steps for the research work and development of the system concept in the remaining time of METIS are given.

**Keywords:**

System Concept, Horizontal Topics, Direct Device-to-Device Communication, Massive Machine Communication, Moving Networks, Ultra-Dense Networks, Ultra-Reliable Communication, Architecture, Technology Components



## Executive summary

The overall purpose of METIS is to develop a system concept that meets the requirements of the beyond-2020 connected information society and extend today's wireless communication systems to support new usage scenarios. This is an immense task, residing at a level that is different from the level at which detailed technical innovations are created. Therefore, the task of overall METIS system concept has been segmented into system concepts related to five Horizontal Topics (HTs): (1) **D2D** - Direct Device-to-Device Communication, (2) **MMC** - Massive Machine Communication, (3) **MN** - Moving Networks, (4) **UDN** - Ultra-Dense Networks, and (5) **URC** - Ultra-Reliable Communication.

This document provides a first view on the system concepts associated with each HT and indicates the steps and directions towards integrating them into an overall METIS system concept in the remaining time frame of the project. Each HT creates a context for applying and optimizing the Technology Components (TeC) in the Work Packages (WPs). For example, Massive MIMO is a generic technology that can give rise to innovations applicable in UDN and supporting the performance requirements specified by URC. The five HTs are not independent and their interaction is the basis for creating the architecture that is capable to achieve the main objectives for METIS [MET13-D11]:

- 1000 times higher mobile data volume per area,
- 10 to 100 times higher typical user data rate,
- 10 to 100 times higher number of connected devices,
- 10 times longer battery life for low power devices,
- 5 times reduced E2E latency.

These objectives have to be met at a similar cost and energy consumption as today's networks. The research challenge is amplified by considering that the wireless scenarios in 2020 will feature communication modes and services that are not merely "more and faster of what we have today". As an example, the vehicles of the future that are interconnected with very high reliability and low latency, improving the efficiency and safety on the road. The METIS system will respond to the requirements for improved: 1) **efficiency** in terms of energy, cost and resource utilisation than today's system 2) **versatility** to support a significant diversity of requirements, e.g. connections in Gbps from few devices vs. connections in kbps from many machine-type devices, inclusion of moving networks vs. statically deployed sensors, etc. 3) **scalability** in terms of number of connected devices, densely deployed access points, spectrum, energy and cost.

The concepts presented in this document are clearly demonstrating the capability of the HTs to channelize the technical innovations towards creating the overall METIS system. The highlights for the system concepts of the individual HTs are given as follows:

- The HT D2D concept addresses the utility of the local exchange of information among the devices and creates a framework for solving the associated technological challenges. Putting D2D connectivity as a basic architectural element in the 5G system, rather than having it as an add on to an already existing architecture, leads to multiple benefits: increased coverage (availability and reliability), offload backhaul (cost efficiency), provide a fall-back solution (reliability), improve spectrum usage (spectrum efficiency), typical user data rate and capacity per area (capacity density), and enable highly reliable, low-latency Vehicle-to-Infrastructure (V2X) connections. Efficient D2D operation critically depends on interference management, resource allocation, efficient relaying for coverage extension, etc.
- The HT MMC concept contains the technologies for radio access that will be capable to support an unprecedented number of devices. They are segmented into three types of radio access: (1) direct access, which devices transmit directly to the access node; (2) access through accumulation/aggregation point; and (3) machine-type



communication between devices. The TeCs used to support these types of access fall in several categories: overlay of multiple transmissions (by means of quasi-orthogonal random access, sparse coding, successive interference cancellation, and reuse of resource by short-range links), smart pre-allocation of resources (persistent scheduling), techniques to lower the sync requirements and context/service-aware configuration of the radio access.

- The HT MN concept introduces innovative directions for the future relationship between vehicles and wireless communications. Three clusters are defined: (1) MN for mobility-robust high-data rate communication links (MN-M), to enable broadband as well as real-time services in mobile terminals and moving relays; (2) MN for nomadic network nodes (MN-N), to enable a flexible and demand-driven network deployment; (3) MN for V2X communications (MN-V), to enable reliable and low-latency services such as road safety and traffic efficiency. While the MN-M cluster represents an evolutionary improvement of the existent technology addressing highly mobile scenarios, the MN-N and MN-V clusters introduce a paradigm shift in the usage of mobile communications.
- The HT UDN has defined a core specific concept optimized for the potential stand-alone operation of a layer of ultra-densely deployed small cells. Beside considerations on a new spectrum flexible air interface, it foresees a potentially tight collaboration of nodes w.r.t. resource allocation coordination, a fast (de-)activation of cells and inbuilt self-backhauling support. An extended UDN concept offers additional performance improvement by: 1) Context awareness for mobility, resource and network management, 2) inter-RAT/ inter-operator collaboration, 3) tight interaction of a UDN layer with a macro layer holding superior role in control and management functions over common area, and 4) macro-layer based wireless backhaul for flexible and low-cost UDN deployments.
- The HT URC system concept targets operation modes that are not present in today's systems. URC-L (Long-term URC) targets the following operation mode: when not possible to operate at the peak rate, provide reliable moderate rates to all users instead of failing some of them. URC-L will be instrumental for the cloud-based services of the future. URC-S (Short-term URC) aims to guarantee latency despite the competition from multiple users and varying channels and will be critical for e.g. V2X connectivity. URC-E (URC for Emergency) aims to provide minimal guaranteed connectivity upon infrastructure damage. A generic URC toolbox consists of: spectrum allocation and management, robust PHY mechanisms, signalling structure and interface management, Multi-RAT and reliable service composition.

Based on the current view on the system concept, METIS has selected two technology components for implementation test-beds. The technology components are "Direct network controlled device to device communication with interference cancellation" to be implemented on the Radio Resource Management test-bed, and "FBMC/OQAM new waveform" for the Digital Base-Band test-bed.

The HT-specific concepts will be integrated towards the overall METIS system, which will contain new air interfaces as well as the evolved versions of today's systems. In order to deal with such a level of complexity and support the required reliability/scalability, the METIS system will feature Software-Defined Networking (SDN), Network Function Virtualization (NFV), and Self-Organizing Network (SON) technologies.

The next steps of the work on the METIS system concept in the project include: further integration of the specific HT concepts with the METIS architecture, further positioning of METIS technical goals by the evaluation criteria defined for 5G systems and establishment of a technology roadmap for the deployment of the METIS 5G system.



## Contents

1	Introduction .....	1
1.1	Structure of the document .....	2
1.2	Acknowledgment .....	2
2	Horizontal topics in METIS .....	3
2.1	Direct Device-to-Device (D2D) .....	3
2.1.1	Description .....	3
2.1.2	SWOT analysis .....	4
2.1.3	Test cases addressed by D2D .....	5
2.2	Massive Machine Communication (MMC) .....	5
2.2.1	Description .....	5
2.2.2	SWOT analysis .....	6
2.2.3	Test cases addressed by MMC .....	7
2.3	Moving Networks (MN) .....	7
2.3.1	Description .....	7
2.3.2	SWOT analysis .....	9
2.3.3	Test cases addressed by MN .....	10
2.4	Ultra-Dense Networks (UDN) .....	10
2.4.1	Description .....	10
2.4.2	SWOT analysis .....	12
2.4.3	Test cases addressed by UDN .....	13
2.5	Ultra-Reliable Communication (URC) .....	13
2.5.1	Description of the HT .....	13
2.5.2	SWOT Analysis .....	16
2.5.3	Test cases addressed by URC .....	16
2.6	HTs and the METIS test cases .....	16
3	METIS 5G system concept .....	18
3.1	First view of the METIS 5G system concept .....	18
3.1.1	METIS network architecture .....	19
3.2	HT concepts .....	20
3.2.1	D2D .....	20
3.2.2	MMC .....	25
3.2.3	MN .....	30
3.2.4	UDN .....	37
3.2.5	URC .....	43
3.3	Meeting the METIS goals .....	48
3.3.1	1000 times higher mobile data volume per area .....	49
3.3.2	10 to 100 times higher typical user data rate .....	50
3.3.3	10 to 100 times higher number of connected devices .....	51
3.3.4	10 times longer battery life for low power MMC devices .....	52
3.3.5	5 times reduced End-to-End (E2E) latency .....	52
3.4	Continued METIS 5G system concept development .....	53
4	Conclusions and future work .....	56
5	References .....	58
6	Annex: Test-beds .....	63
6.1	Test-bed purpose .....	63
6.2	Test-bed overview .....	63
6.2.1	Radio Resource Management test-bed .....	63
6.2.2	Digital Baseband test-bed .....	63
6.2.3	Implementation decisions .....	63
7	Annex: METIS test cases .....	65
8	Annex: METIS Horizontal Topics .....	66
8.1	HT Moving Networks: Definition of HT MN Clusters .....	66
8.2	Description of HT Ultra Reliable Communication .....	66



8.2.1	Reliability Aspects .....	66
8.2.2	The Problem of Reliable Service Composition .....	67
9	Annex: HT concepts .....	69
9.1	HT Moving Networks .....	69
9.1.1	Definition of Mobility Aspects .....	69
9.1.2	Additional Information on the Concept of MN for Mobility-Robust High-Data Rate Communication Links (MN-M) .....	72
9.1.3	Additional Information on the Concept of MN for Nomadic Network Nodes (MN-N) .....	79
9.1.4	Additional Information on the Concept of MN for V2X Communications (MN-V) .....	87
9.2	HT Ultra Dense Networks .....	94
9.2.1	UDN Concept – core part .....	94
9.2.2	Extended UDN Concept – Context Awareness .....	101
9.2.3	Extended UDN Concept – RAT selection, spectrum sharing aspects and network interfaces .....	102
9.2.4	Extended UDN Concept – Wireless Backhauling for UDN from macro site ....	104
9.2.5	Extended UDN Concept – Macro cell in superior role to UDN .....	105



## List of Figures

Figure 2-1: Exemplary usage of direct D2D communication scenarios. ....	4
Figure 2-2: SWOT analysis of HT D2D. ....	4
Figure 2-3: Schematic illustration of HT MMC. ....	6
Figure 2-4: SWOT analysis of HT MMC. ....	7
Figure 2-5: The three clusters of HT Moving Networks (MN). ....	9
Figure 2-6: SWOT analysis of HT MN. ....	10
Figure 2-7: Example of UDN deployments based on METIS test cases. ....	11
Figure 2-8: SWOT analysis of HT UDN. ....	13
Figure 2-9: Workflow for HT URC. ....	15
Figure 2-10: SWOT analysis of HT URC. ....	16
Figure 3-1: Generic METIS 5G network architecture (high-level view). ....	19
Figure 3-2: METIS HT D2D concept. ....	21
Figure 3-3: HT MMC illustrated in the case of a) direct access, b) accumulation point access, and c) M2M access. ....	26
Figure 3-4: MMC concept illustration. The size of concept components relate to the relevance for MMC and the opacity to the maturity level. Relations to other HTs are indicated by arrows. ....	30
Figure 3-5: MN system concept based on mobility aspects. ....	31
Figure 3-6: MN concept proposal – MN for mobility-robust high-data rate communication links. ....	33
Figure 3-7: MN concept proposal – MN for nomadic network nodes. ....	35
Figure 3-8: MN concept proposal – MN for V2X communications. ....	37
Figure 3-9: Concept proposal for UDN. ....	38
Figure 3-10: The keystone TeCs for proposed UDN concept TeCs mapped on protocol layers 1 and 2 with an indication of ongoing (solid arrow) and potential (dashed arrow) collaboration. ....	39
Figure 3-11: Toolbox of generic mechanisms for URC and their interactions. ....	44
Figure 3-12: Illustrative graph for URC-L where the average rate is depicted as a function of the number of users. ....	45
Figure 3-13: Illustrative graph for URC-S where the latency is depicted as a function of the number of users. ....	47
Figure 3-14: Mapping of the METIS Goals to the METIS concept via HTs. ....	54
Figure 3-15: Examples of interactions and synergies among the HTs. ....	55
Figure 9-1: Detailed concept for MN-M covering Mobility Aspect 1. ....	76
Figure 9-2: Detailed concept for MN-M covering Mobility Aspect 2. ....	77
Figure 9-3: Detailed concept for MN-M covering Mobility Aspect 3. ....	78
Figure 9-4: Detailed concept for MN-N covering Mobility Aspect 2. ....	84
Figure 9-5: Detailed concept for MN-N covering Mobility Aspect 3. ....	87
Figure 9-6: Detailed concept for MN-V covering Mobility Aspect 1. ....	91



Figure 9-7: Detailed concept for MN-V covering Mobility Aspect 2. .... 92

Figure 9-8: Detailed concept for MN-V covering Mobility Aspect 4. .... 94

Figure 9-9: WP2/UDN relevant TeCs mapped on protocol layer 1 and 2 with an indication of ongoing (solid arrow) and potential (dashed arrow) collaboration. .... 97





## List of Tables

Table 2-1: HTs and METIS test cases. ....	17
Table 3-1: HTs and METIS goals. ....	49
Table 9-1: Analysis of mobility aspects in MN-M. ....	75
Table 9-2: Analysis of mobility aspects in MN-N. ....	83
Table 9-3: Analysis of mobility aspects in MN-V. ....	90



## List of Abbreviations, Acronyms, and Definitions

<b>3G</b>	Third-generation
<b>3GPP</b>	3 <sup>rd</sup> Generation Partnership Project
<b>4G</b>	Fourth-generation
<b>AI</b>	Air Interface
<b>AP</b>	Access Point
<b>APSM</b>	Adaptive Projected Sub-gradient Method
<b>BF</b>	Beam Forming
<b>BS</b>	Base Station
<b>C-RAN</b>	Cloud-RAN
<b>CA</b>	Candidate Antenna
<b>CAPEX</b>	Capital Expenditure
<b>CDN</b>	Content Delivery Network
<b>CN</b>	Core Network
<b>CoMP</b>	Coordinated MultiPoint
<b>CSI</b>	Channel State Information
<b>CSIR</b>	CSI at the receiver
<b>D</b>	Deliverable
<b>DL</b>	Downlink
<b>D2D</b>	Device-to-Device
<b>DFT</b>	Discrete Fourier Transform
<b>DSP</b>	Digital Signal Processing
<b>eICIC</b>	enhanced ICIC
<b>eNB</b>	evolved Node B
<b>E2E</b>	End-to-End
<b>FBMC</b>	Filter Bank MultiCarrier
<b>FDD</b>	Frequency Division Duplex
<b>FMC</b>	Fixed-Mobile Convergence
<b>GMSK</b>	Gaussian Minimum Shift Keying
<b>HARQ</b>	Hybrid Automatic Repeat Request
<b>HO</b>	Hand-Over
<b>HT</b>	Horizontal Topic
<b>ICIC</b>	Inter-Cell Interference Coordination
<b>IEEE</b>	Institute of Electrical and Electronics Engineers
<b>IP</b>	Internet Protocol
<b>IRC</b>	Interference Rejection Combining
<b>ISD</b>	Inter Site Distance
<b>ISM</b>	Industrial, Scientific and Medical radio bands
<b>KPI</b>	Key Performance Indicator
<b>L</b>	Layer
<b>LAN</b>	Local Area Network
<b>LOS</b>	Line Of Sight
<b>LSA</b>	Licensed Shared Access
<b>LTE</b>	Long Term Evolution
<b>LTE-A</b>	Long Term Evolution-Advanced
<b>M2M</b>	Machine to Machine
<b>MA</b>	Mobility Aspect
<b>MAC</b>	Medium-access Control
<b>METIS</b>	Mobile and wireless communications Enablers for the Twenty-twenty Information Society
<b>MIMO</b>	Multiple-Input Multiple-Output
<b>MISO</b>	Multiple-Input Single-Output

<b>MMC</b>	Massive Machine Communication
<b>MMSE</b>	Minimum Mean Square Error
<b>mmW</b>	millimetre Waves
<b>MN</b>	Moving Networks
<b>MNO</b>	Mobile Network Operator
<b>MTBF</b>	Mean Time Between Failures
<b>MTC</b>	Machine Type Communication
<b>MTTR</b>	Mean Time To Repair
<b>NFV</b>	Network Function Virtualization
<b>NGMN</b>	Next Generation Mobile Networks
<b>NW</b>	Network
<b>OFDM</b>	Orthogonal Frequency-Division Multiplexing
<b>OPEX</b>	Operational Expenditure
<b>OQAM</b>	Orthogonal QAM
<b>ORP</b>	Outage Rate Probability
<b>PA</b>	Predictor Antenna
<b>PCC</b>	Phantom Cell Concept
<b>PHY</b>	Physical layer
<b>QAM</b>	Quadrature Amplitude Modulation
<b>QoE</b>	Quality of user Experience
<b>QoS</b>	Quality of Service
<b>RA</b>	Receive Antenna
<b>RAN</b>	Radio Access Network
<b>RAT</b>	Radio Access Technology
<b>RF</b>	Radio Frequency
<b>RG</b>	Resource Group
<b>RLA</b>	ReLiability Aspect
<b>RRM</b>	Radio Resource Management
<b>SDN</b>	Software-Defined Network
<b>SINR</b>	Signal to Interference plus Noise Ratio
<b>SoC</b>	System on Chip
<b>SON</b>	Self-Organizing Network
<b>SOS</b>	Switch Off Scheme
<b>SRTA</b>	Separate Receive and Training Antennas
<b>SWOT</b>	Strengths, Weaknesses, Opportunities and Threats
<b>T</b>	Task
<b>TC</b>	Test Case
<b>TeC</b>	Technology Component
<b>TeCC</b>	TeC Cluster
<b>TDD</b>	Time Division Duplex
<b>TTI</b>	Transmission Time Interval
<b>Tx</b>	Transmitter
<b>U-NII</b>	Unlicensed National Information Infrastructure
<b>UDN</b>	Ultra-Dense Networks
<b>UE</b>	User Equipment
<b>UFMC</b>	Universal Filtered MultiCarrier
<b>UL</b>	Uplink
<b>URC</b>	Ultra-Reliable Communication
<b>URC-E</b>	URC for emergency
<b>URC-L</b>	URC over a long term
<b>URC-S</b>	URC in a short term



<b>USRP</b>	Universal Software Radio Peripheral
<b>V2D</b>	Vehicle-to-Device
<b>V2I</b>	Vehicle-to-Infrastructure
<b>V2V</b>	Vehicle-to-Vehicle
<b>V2X</b>	Vehicle-to-D, I or V

<b>VUE</b>	Visual Understanding Environment
<b>WLAN</b>	Wireless Local Area Network
<b>WP</b>	Work Package
<b>WRC</b>	World Radiocommunication Conference



## 1 Introduction

The overall purpose of METIS is to develop a system concept that meets the requirements of the beyond-2020 connected information society and extend today's wireless communication systems to support new usage scenarios. Such a system has to:

- Be significantly more **efficient** in terms of energy, cost and resource utilisation than today's system, in order to allow for a constant growth in capacity at acceptable overall cost and energy dissipation,
- Be more **versatile** to support a significant diversity of requirements (e.g. Availability, Mobility, Quality-of-Service) and use cases, and
- Provide better **scalability** in the way that the system is cost, energy and resource efficient while responding to a wider range of requirements regardless of whether a large or low amount of traffic is to be supported.

The technical goals derived from these main objectives for METIS are [MET13- D11]:

- 1000 times higher mobile data volume per area,
- 10 to 100 times higher typical user data rate,
- 10 to 100 times higher number of connected devices,
- 10 times longer battery life for low power devices,
- 5 times reduced End-to-End (E2E) latency.

The key challenge is to meet these goals at a similar cost and energy consumption as today's networks.

These METIS goals apply for different usage scenarios [MET13-D11] but do not have to be realized simultaneously. The overall METIS system is therefore designed as highly flexible and configurable in order to adapt to the different Test Cases (TCs) defined in the project [MET13-D11] by emphasizing different technical challenges.

To meet its objectives the METIS project follows a two-fold research approach towards the overall system concept: vertical Work Packages (WP) perform research on Technology Components (TeCs) and Horizontal Topics (HT) integrate the TeCs to build the METIS system [METIS14]. The main research directions in the WPs address:

- Air-interface design, waveforms and multiple access,
- Multi-node coordination, multi-antenna, and multi-hop communication,
- Heterogeneous multi-layer and multi-RAT deployments,
- Frequency band analysis, flexible spectrum access, coexistence,

and the five essential HTs selected in the project are:

- Direct Device-to-Device Communication (D2D),
- Massive Machine Communication (MMC),
- Moving Networks (MN),
- Ultra-Dense Networks (UDN),
- Ultra-Reliable Communication (URC).

This document shows how the selected HTs in METIS contribute to the main technical goals and their role in the project to build the overall METIS system concept. It is described how the TeCs researched by the WPs are integrated by each HT for its specific requirements towards a specific HT concept.



The overall METIS system concept is then built by the further integration of the HT concepts taking also their commonalities into account. A first view on the overall system concept is given in this document by addressing the methods and technologies developed to address the METIS objectives at this intermediate stage of the project.

The document shows the progress on the HT's work and indicates the next steps for the research work on the system concept in the remaining time frame of the project.

## **1.1 Structure of the document**

In Section 2 a detailed definition and the analysis of the HTs in METIS is presented together with a Strengths, Weaknesses, Opportunities and Threats (SWOT) analysis for each HT. This emphasizes how the selection of the HTs has been achieved in the project. A common section recalls how the HTs address the five main METIS technical goals.

Section 3 presents a first view on the overall METIS system concept. The integration of TeCs from the WPs by the HTs is shown leading to a specific concept for each HT. Commonalities utilized in the further integration of the specific HT concepts are described. These correspond to the research results achieved in the project at this intermediate stage. Conclusions and next steps for the further work in the project are given at the end of the document.

This document contains an Annex. Section 6 describes technology components selected for implementation in test-beds based on the current view of the system concept. Section 7 lists the METIS test-cases. Section 8 contains further details on the HT definitions. Finally, additional specific HT concept details are given in Section 9.

## **1.2 Acknowledgment**

The authors would like to acknowledge the support of Elisabeth De Carvalho (Aalborg University), Konstantinos Koufos (Aalto University), André Santos (Alcatel-Lucent Bell Labs), Tommi Jämsä (Anite), Mladen Botsov, Zhe Ren (BMW Group), Eric Ström, Tommy Svensson (Chalmers University of Technology), Richard Abrahamsson, Gabor Fodor (Ericsson AB), Nadia Brahmī, Tim Irnich (Ericsson GmbH), Hao Lin (France Telecom - Orange), Renato L. G. Cavalcante (Fraunhofer HHI), Malte Schellmann, Chan Zhou (Huawei ERC), Konstantinos Chatzikokolakis, Alex Kaloxylos, Panagiotis Spapis (National and Kapodistrian University of Athens), Tero Ihalainen, Mikko Uusitalo (Nokia), Eeva Lähetkangas, Michal Maternia (Nokia Solutions and Networks), Roberto Fantini (Telecom Italia), Sandra Roger (Universitat Politècnica de València), Carsten Bockelmann (University of Bremen), Andreas Klein, Hans Schotten (University of Kaiserslautern), and Nandana Rajatheva (University of Oulu).



## 2 Horizontal topics in METIS

The role of the HTs in METIS is to integrate the TeCs researched by the WPs into the overall METIS concept. The HTs address the METIS technical goals stated in [MET13-D11] in the different perspectives of the Test Cases (TCs) defined in the project, see Annex Section 7. In this section each of the five METIS HTs is described in detail giving the motivation behind its definition; for each HT a SWOT analysis is further provided. The main relevant TCs are given for each HT as well. The last section summarizes how the METIS technical goals are addressed by the HTs. The detailed integration of the researched TeCs into HT specific concepts is shown in Section 3.

### 2.1 Direct Device-to-Device (D2D)

#### 2.1.1 Description

Direct Device-to-Device (D2D) communication refers to network-controlled direct communication between devices without Core Network (CN) involvement in the data path of local D2D communication. In most case radio access network (RAN) is not involved either except in the relayed D2D case, Section 3.2.1. METIS aims to integrate direct D2D communication as part of the overall mobile and wireless communication system. The objectives of the HT D2D are to increase coverage (availability and reliability), offload backhaul (cost efficiency), provide a fall-back solution (reliability), improve spectrum usage (spectrum efficiency), typical user data rate and capacity per area (capacity density), and provide enabler for new services and experiences for example V2X communication as described in [MET13-D11], where E2E latency is crucial. With network-controlled direct D2D communication (i.e. at least one of the involved devices is connected to the cellular network), D2D can contribute to METIS technical goals in various ways via for example traffic offloading and local information exchange:

- 1000 times higher mobile data volume per area,
- 10 to 100 times higher typical user data rate,
- 5 times reduced E2E latency.

Network controlled direct D2D communication offers the opportunity for local management of short-distance communication links, which allows separating local traffic from the global network (i.e. local traffic offloading). This will not only significantly unburden the load on the backhaul and CN caused by data transfer and signalling, but also reduce the effort necessary for traffic management at the central network nodes for example S-GW and P-GW (if using 3GPP LTE terminology). Based on direct D2D communication, local data sharing zones can be easily set up, allowing content sharing by a large number of users without putting heavy load on the global network. Direct D2D communication therefore extends the idea of distributed network management by incorporating the end devices themselves into the network management concept.

Further, direct D2D links facilitate communication at low latency due to the local communication link as well as very reliable communication because of the potential diversity gain if e.g. the same data packet is delivered via both regular cellular link and via D2D, which are seen as necessary features to support safety critical or real-time services. From this aspect, one can say that D2D is enabling functionalities of URC.

Moreover, due to the short distance transmission, the device power consumption can be reduced significantly especially if D2D is operated on the same carrier as cellular network.

In another flavour of direct D2D communication, mobile devices may act as relay stations in a multi-hop transmission environment from distant mobiles to base stations. Exemplary use cases considered within METIS are illustrated in Figure 2-1.

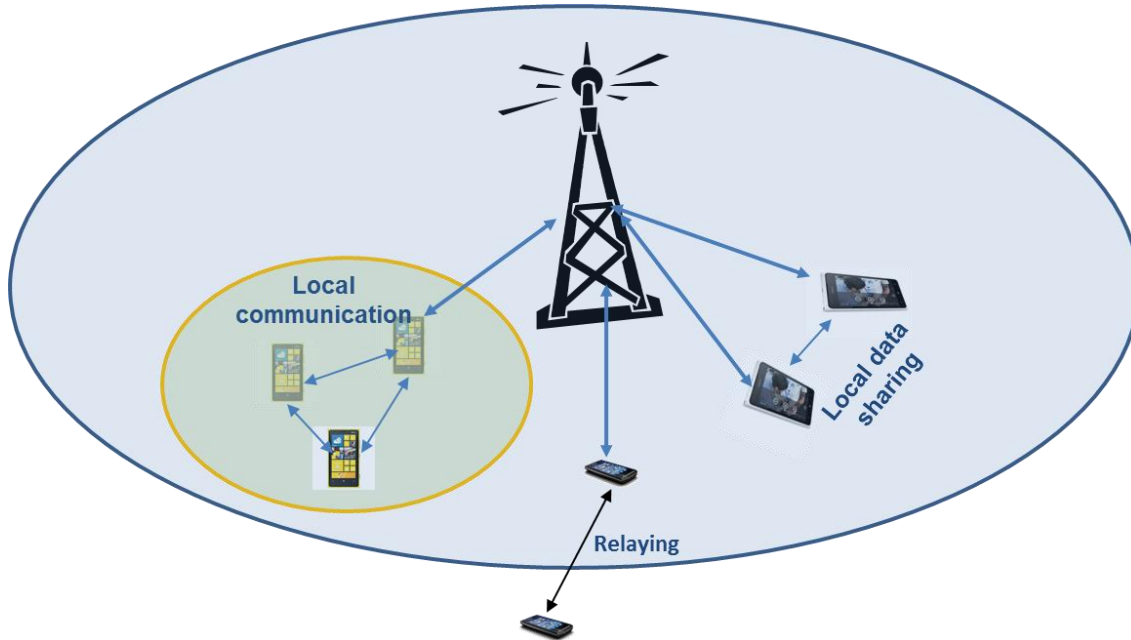

Figure 2-1: Exemplary usage of direct D2D communication scenarios.

### 2.1.2 SWOT analysis

The SWOT analysis of HT D2D is given in Figure 2-2.

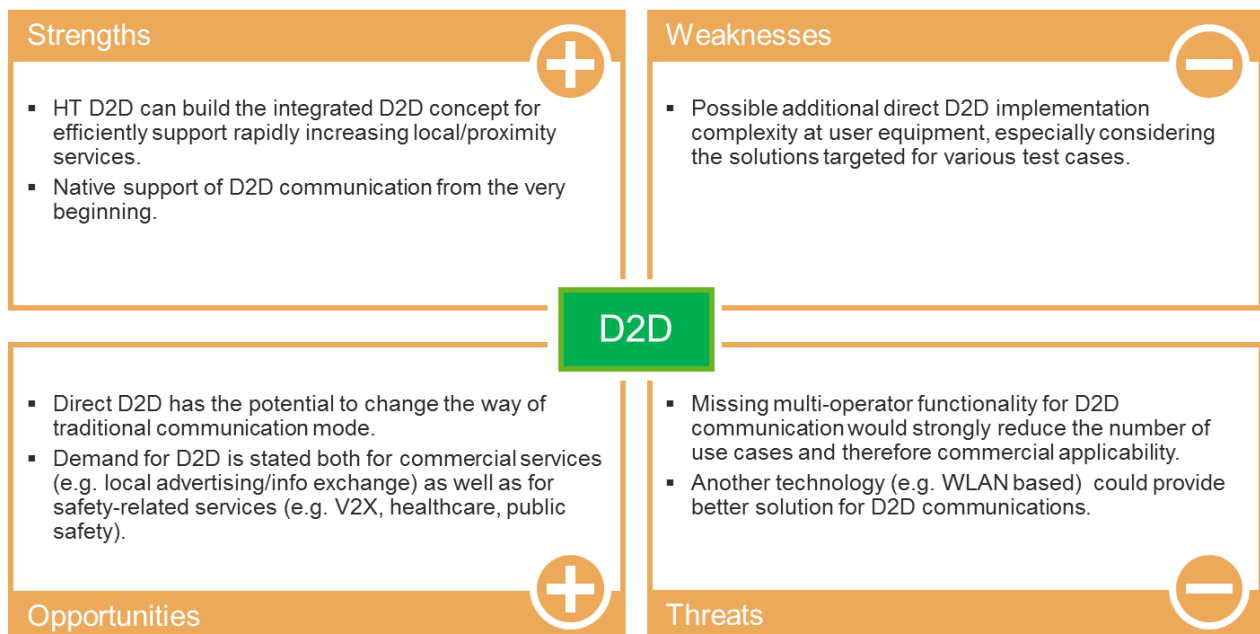

Figure 2-2: SWOT analysis of HT D2D.



### 2.1.3 Test cases addressed by D2D

D2D is relevant to all the TCs where there is potential to establish direct D2D links for different purposes. For example supporting device centric services in TC2 (Dense urban information society), exchange information locally among devices in TC3 (Shopping mall), TC4 (Stadium), TC6 (Traffic jam) and TC9 (Open air festival), improving traffic safety in TC12 (Traffic efficiency and safety), coverage extension in TC10 (Emergency communications) and so on. Within METIS, it has been identified that the TCs 2, 3, 4, 6, 9, 10, and 12 are highly related to D2D HT. And D2D based solutions can handle the related technical challenges and meet the requirements derived from TCs [MET13-D11]. Additional TC information is given in Annex, Section 7.

## 2.2 Massive Machine Communication (MMC)

### 2.2.1 Description

Massive Machine Communication (MMC) is intended to expand the wireless connectivity from humans to machine devices and this will be one of the most important changes for future wireless communications system. The aims of the HT are to provide scalable connectivity solutions for tens of billions of network-enabled devices. Machine-related communication will be associated with a wide range of characteristics and requirements (e.g. data rate, latency, cost, power consumption, availability and reliability) that will often deviate substantially from those of human-centric communication in current use, see Figure 2-3.

In this context, the challenge for future wireless networks is to accommodate the traffic from all of these applications. In addition, machine type communications should co-exist with normal human-centric communication. In this respect the challenge for 2020 wireless communications systems, and hence for METIS, is to build a radio interface which efficiently accommodates traffic from applications of totally different nature in terms of data rates, latency and reliability requirements.

Therefore the work in METIS towards MMC focuses on the definition of a radio interface which can accommodate these different communication types. Hence, radio interface design is a significant part of the work. Main focus in this design should be

- Low energy,
- Low cost,
- Availability, i.e. coverage,
- Low signalling overhead,
- Extremely high number of connected devices.

Qualitatively these requirements are similar to those of the ongoing Machine Type Communication (MTC) activities in 3GPP Release 12 [3GPP13-36888]. The difference is that METIS requirements quantitatively are set higher and such that overall system changes, such as a new air interface, new architecture etc. must be considered to reach them.



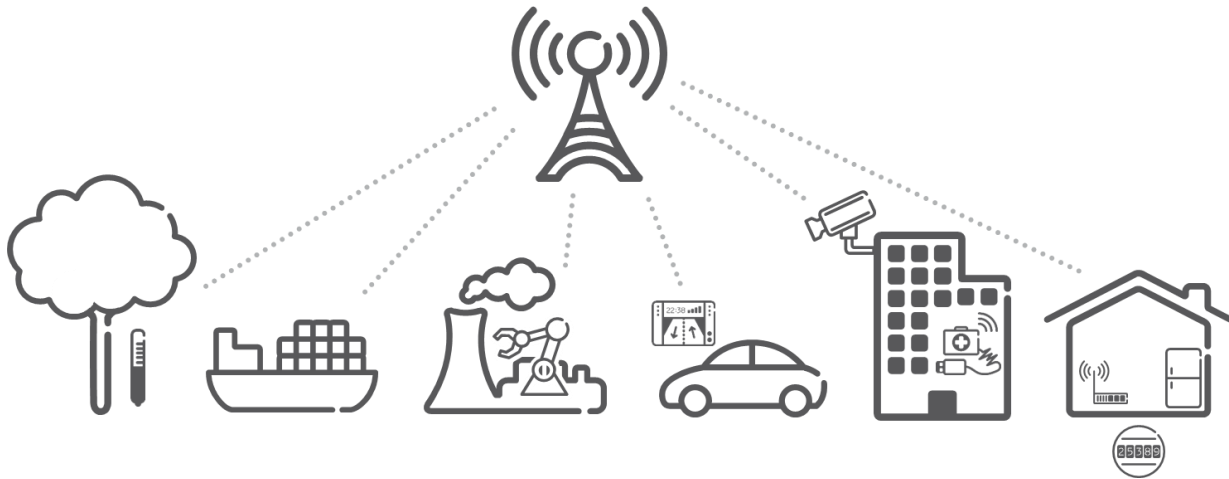

**Figure 2-3: Schematic illustration of HT MMC.**

The motivation for developing a radio interface and a radio access network being able to accommodate traffic from machine type communications is the huge impact that this type of communication is going to have in our everyday life: very high number of sensors connected with servers, mobile phones, tablets, etc. and augmenting our awareness of the environment and of our surroundings. In order to enable the future information society, METIS has to address these challenges for the radio interface and the radio interface network respectively. In this direction, METIS has set its goals in terms of radio system and radio link performance and the ones which are going to be addressed within this horizontal topic are:

- 100 times higher number of connected devices,
- 10 times longer battery life for low power devices,

at similar cost and energy consumption as today.

The main challenge for METIS HT MMC is that devices should be of low cost, they should have low energy consumption to avoid the need for frequent battery charging, and coverage should be provided everywhere without massive investments in network infrastructure by operators or other actors.

Another decisive factor for the take-off of MMC is the easiness of these devices to access the radio access network and since direct device-to-device connections between machines (M2M, see Section 3.2.2.1 for differences to regular D2D) and multi-hop connections play an important role, it is of paramount importance that the radio access technology to be used from these devices is similar to the one used by most of the network nodes and other terminals, sensors, devices, access points in the network. Further, with regards to system integration, there are two main tracks in the air interface design, depending on the environment and deployment:

- Common radio interface for both human-centric mobile broadband services and MMC,
- Separate radio interfaces for MMC and human-centric mobile broadband services.

## 2.2.2 SWOT analysis

The SWOT analysis of HT MMC is given in Figure 2-4.

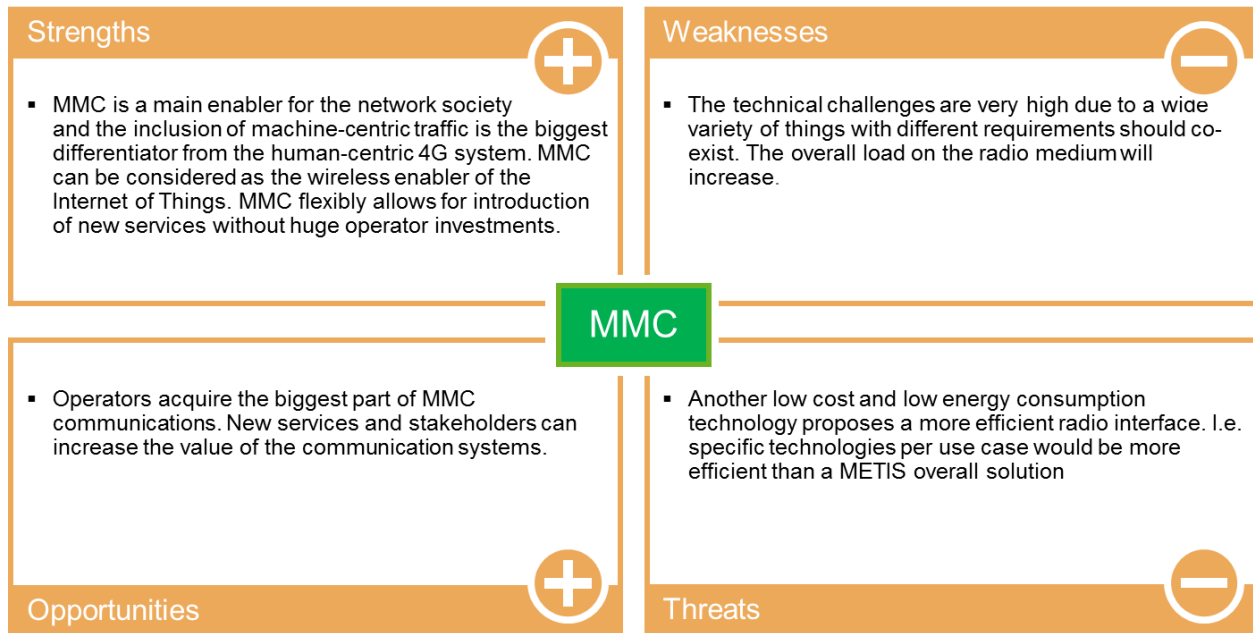

Figure 2-4: SWOT analysis of HT MMC.

### 2.2.3 Test cases addressed by MMC

The most relevant test case for MMC is TC11 (Massive distribution of sensors and actuators). In fact TC11 emphasizes large quantities of sensors and actuators with small payloads, which is the core of HT MMC. Further TC2 (Dense urban information society), TC3 (Shopping mall), and TC9 (Open air festival) are relevant for HT MMC since they in different scenarios include both the aspects of large number of connected devices and communication with a machine type flavour. Finally, TC5 (Teleprotection in smart grid network) and TC12 (Traffic efficiency and safety), which are the mainly covered by HT URC and HT MN respectively, are also partially relevant for HT MMC. In Annex, Section 7, some additional TC related information is given.

## 2.3 Moving Networks (MN)

### 2.3.1 Description

The usage of broadband services via mobile devices (such as smart-phones and tablets) is becoming increasingly popular. People no longer use their devices only at home, but consume services such as internet, email, music and video streaming also on-the-go, e.g. on their way to work, while using public transport or driving their cars. This will become even more important in 2020, when the connected society will make use of even more bandwidth-demanding services like augmented reality and virtual office applications. The challenge to realize these services not only lies in the provision of high-data rate communication links for mobile terminals, but also in the fact that these services require low-latency transmissions, especially when considering terminals that move with high speeds. Moreover, vehicles tend to provide more and more communications capabilities and integrated communications infrastructure in the future. This means that future vehicles and transportation systems may play an integral role in future wireless networks. In fact, they may become part of the cellular network infrastructure that helps to improve the capacity, coverage and deployment by providing their on-board communications infrastructure to the cellular network. This allows for a flexible deployment of vehicular network infrastructure based on capacity, coverage, or traffic demand. Besides that such moving network



nodes improve the environmental sensing capabilities of transportation systems. The provision of reliable communication links between vehicles and mobile phones of other traffic participants will enable new V2X services based on cellular communications that may improve road safety and traffic efficiency; note that in the latter the term “V2X” refers to Vehicle-to-Vehicle (V2V), Vehicle-to-Infrastructure (V2I), and Vehicle-to-Device (V2D) communications. Vehicular terminals not only have to cope with mobility (even at high speeds) and the need to adapt to varying interference environments, but the involved communication links also have strict reliability requirements that demand the successful transmission of packets with guaranteed maximum E2E latencies. The heterogeneous network deployment which is required to fulfil the capacity-demands in 2020 will be comprised of many small cells but will also combine many different radio access technologies. This makes it even more challenging to fulfil the requirements of moving and nomadic network nodes, and calls for a network deployment that is even more flexible, dynamic and adaptive.

The HT MN focuses on enhancing existing solutions as well as developing novel technology components in order to improve the mobility management and connectivity of moving terminals and moving/nomadic networks. The overall METIS technical goals addressed by this HT are:

- 1000 times higher mobile data volume per area,
- 10 to 100 times higher typical user data rate,
- 5 times reduced E2E latency.

A moving network describes a group of mobile nodes or terminals (e.g. vehicles with advanced communication and networking capabilities) that form a “moving network” which enables the communication between those nodes. It is important to highlight that in this context a moving network is not only restricted to networks within a vehicle, but is also extended to networks between and outside vehicles. Moreover, the concept of nomadic network nodes allows for a flexible deployment of networks depending on traffic, service and coverage demands. A nomadic node describes a network node that provides relay-like communication capabilities, and for which there is uncertainty in its temporal and spatial availability, i.e. a nomadic nodes may shut-down its service, change its geographical position and then become available again. For example, the on-board communications infrastructure that will be deployed in future vehicles may serve for such purposes. According to the previous definition of moving network, the broad and diverse range of application and requirements addressed by the HT can be segmented into the following clusters as represented in Figure 2-5:

- **MN for mobility-robust high-data rate communication links (MN-M)** to enable broadband as well as real-time services in mobile terminals and moving relays.
- **MN for nomadic network nodes (MN-N)** to enable a flexible and demand-driven network deployment.
- **MN for V2X communications (MN-V)** to enable reliable and low-latency services such as road safety and traffic efficiency.

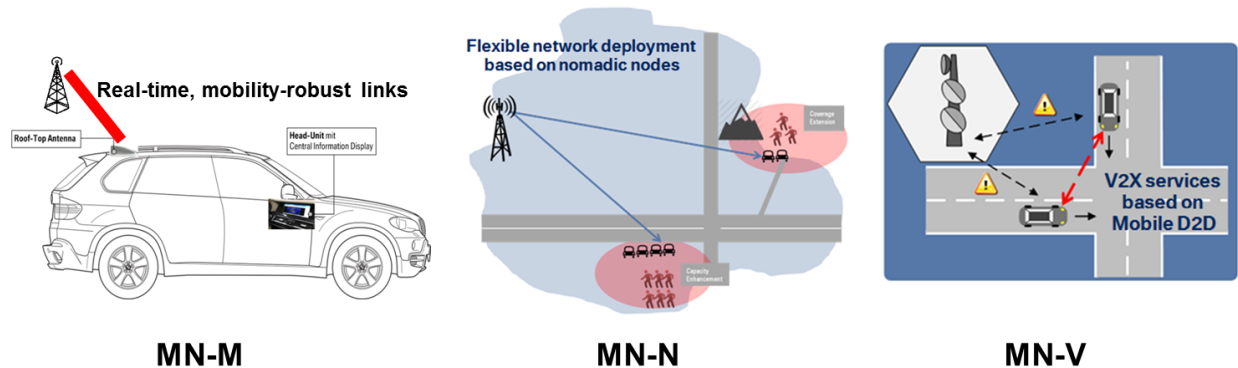

Figure 2-5: The three clusters of HT Moving Networks (MN).

In order to better identify the main challenges faced by the HT MN and evaluate accordingly the technical solutions developed in the METIS project, four mobility aspects have been defined within the context of the HT MN. The mobility aspects cover the main challenges related to the HT MN across all the relevant test cases that have been specified within the METIS project as defined in [MET13-D11]. The four mobility aspects are:

- **MA1 – Link level performance in mobile channels:** this mobility aspect copes with the impairments of the mobile propagation channel at the lower layers of the protocol stack, in particular the Doppler shift caused by the relative movement between communication pairs and the rapid variations of the received signal strength over time due to multipath (i.e. fast fading).
- **MA2 – Handover and cell reselection:** this mobility aspect addresses the problem of guaranteeing a seamless connectivity and improved quality of service, while users or cells are moving through the network.
- **MA3 – Management of nomadic and moving cells:** this mobility aspect copes with the difficulties related to the radio resource management of nomadic (and moving) cells.
- **MA4 – Enablers of mobile D2D:** this mobility aspect considers the problems associated with the use of D2D communications for highly moving terminals. In particular, the short channel coherence time of the channel that renders the collection and reporting of up-to-date Channel State Information (CSI) more complicated (or maybe infeasible with reasonable effort).

For more information on the definition and characteristics of the HT MN Clusters as well as on the mobility aspects, please see Annex, Section 8.1 and Section 9.1 respectively.

### 2.3.2 SWOT analysis

The SWOT analysis of HT MN is given in Figure 2-6.

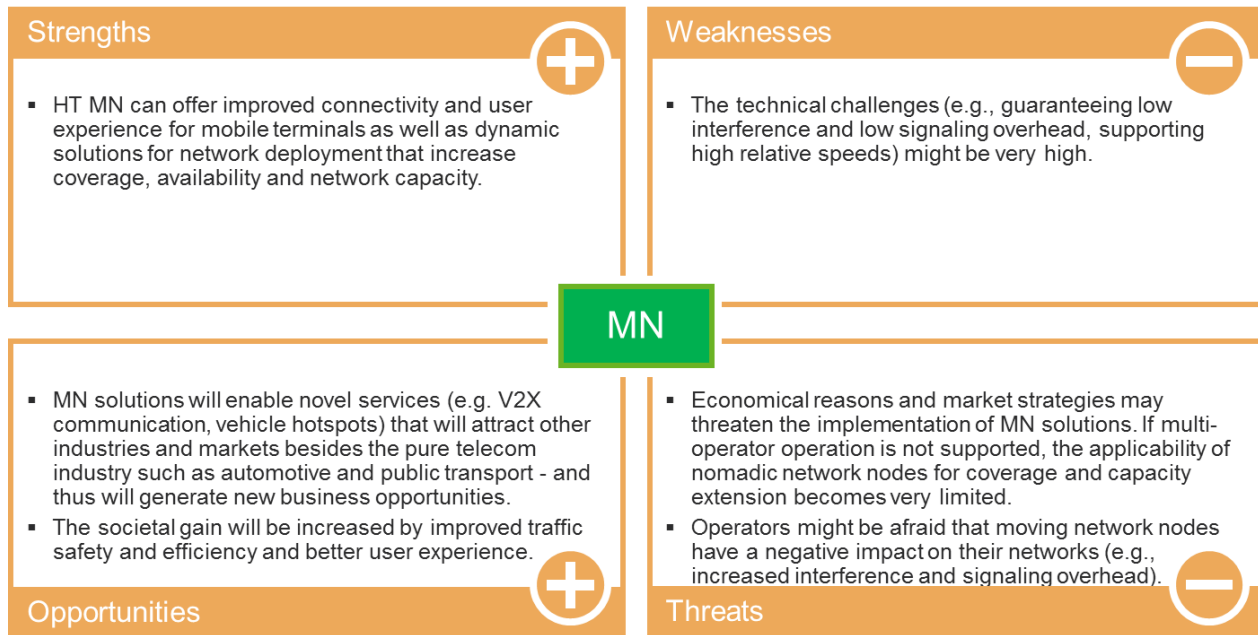

Figure 2-6: SWOT analysis of HT MN.

### 2.3.3 Test cases addressed by MN

The test cases as defined in [MET13-D11] that are addressed by the HT MN can be distributed across the different MN Clusters as follows:

- MN-M cluster:** TC6 (Traffic jam), and TC8 (Real-time remote computing).
- MN-N cluster:** TC6, TC7 (Blind spot), and TC10 (Emergency communications).
- MN-V cluster:** TC10, and TC12 (Traffic efficiency and safety).

More detailed information on the TCs is given in Annex, Section 7.

## 2.4 Ultra-Dense Networks (UDN)

### 2.4.1 Description

The main task for HT UDN is to create new technology enablers that allow for an efficient coexistence of a high number of nodes located in close proximity in hetero- or homogeneous networks. With today's technology, the capacity per area does not scale linearly with the number of nodes per area, as the interference between cells becomes more pronounced for denser deployments and hence the spectral efficiency per cell decreases. Furthermore, very dense deployments lead to severe challenges in terms of mobility signalling overhead and mobility robustness, as simply more handovers are required when devices are moving among cells. Ultimately, a key difficulty w.r.t. ultra-dense networks is that the cost and energy dissipation per area has to stay on the same order as in today's networks, which means that for instance the OPEX per node has to be virtually zero (i.e. nodes have to be fully self-configuring, self-optimizing and self-healing), and one has to be able to activate and deactivate nodes on a fairly fast time scale depending on traffic demand. The HT UDN purpose is to drive the WP's to work on these challenges in a coordinated manner and ultimately address the following METIS overall technical goals:

- 1000 times higher mobile data volume per area,
- 10 to 100 times higher typical user data rate.

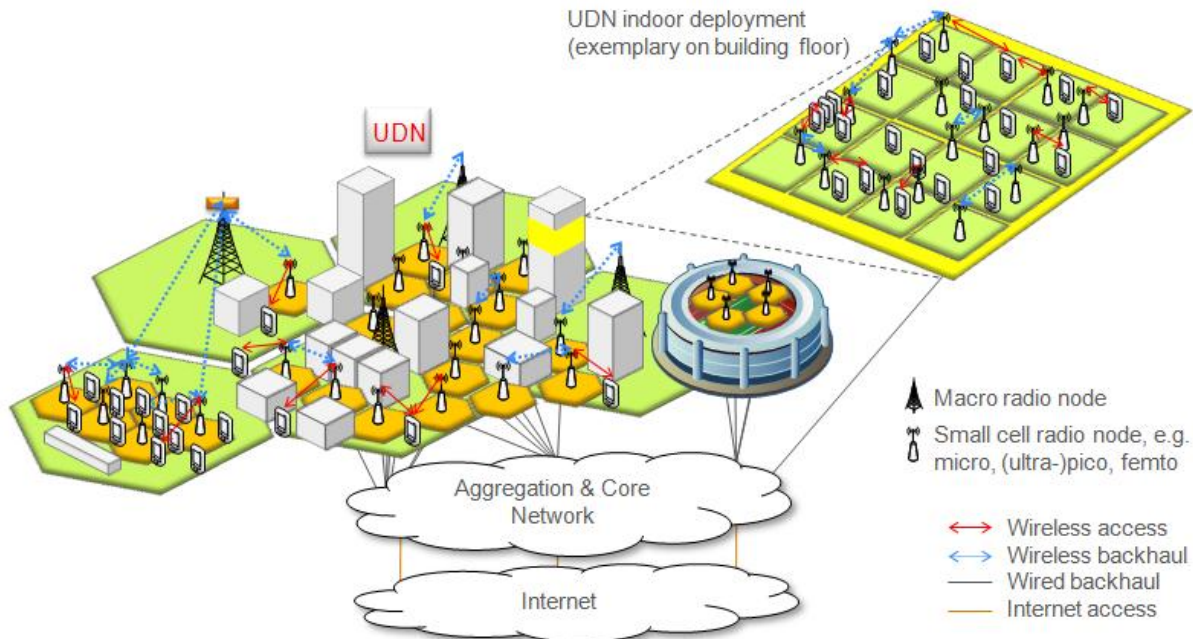

Figure 2-7: Example of UDN deployments based on METIS test cases.

Figure 2-7 illustrates UDN deployments based on the METIS TCs. From the analysis of TCs, technical requirements and challenges for UDN, the horizontal topic can be divided into three key aspects, presented in Section 2.4.1.1 to 2.4.1.3.

#### 2.4.1.1 Aspect #1: Radio access technology

The radio access technology aspect should provide basic answers regarding possibilities of a further evolution based on current LTE-A system or the need of a revolutionary new system non-backward compatible with LTE Release 12 or 802.11(ac/ad) for UDN. In particular, this requires studies on new modulations, optimisation of the physical frame structure for local area communication, utilisation of new spectrum opportunities on mmW, but also the use of link improvement techniques like e.g. massive MIMO on mmW:

- frame structure optimized for dynamic IP traffic,
- spectral efficiency increase, i.e. through,
  - new modulations,
  - enhanced link performance,
  - reduced control signalling overhead,
- low cost, low energy consumption,
- flexible selection and use of spectrum (for new air interface from 3.5 GHz up to 90 GHz),
- flexible UL / DL resource utilization.

#### 2.4.1.2 Aspect #2: Small cell integration and interaction

This aspect is related to functionalities and mechanisms for the interaction and coordination among small cells, e.g. aiming at:



- an optimal selection of candidates for collaboration groups through node clustering,
- advanced neighbourhood discovery for smart and dynamic cluster definition,
- better network performance through short and long term resource / interference management, RAT selection, inter-operator spectrum sharing algorithms,
- The avoidance of in-band/out-of-band coexistence problems through spectrum coordination,
- low number of hand-over (HO) failures in dense deployment (optimized mobility, solving problem of holes in the UDN coverage),
- faster response for rapid changes in network topology or network failures (adding new or removing nodes from the network),
- power safety optimization by planned Access Point's (AP's) periodical activation/deactivation depending on the load in the area,
- network maintenance cost reduction related with simplified network planning and automated tuning of network parameters.

#### **2.4.1.3 Aspect #3: Wireless backhauling**

Future dense deployments will require less planning, optimisation and management when most of these functionalities will be automated and solved by the network itself, which means less predictable needs for backhaul availability. All these arguments lead to the conclusion that wireless backhaul will be a key enabler for further network densification in indoor and outdoor deployments, where in particular

- wireless backhaul for UDN should be self-configurable, adaptive to changes in network topology and network load,
- high link capacity is critical requirement to aggregate traffic,
- low latency on physical layer is a critical enabler for the multi-hop connectivity between nodes.

#### **2.4.2 SWOT analysis**

The SWOT analysis of HT UDN is given in Figure 2-8.

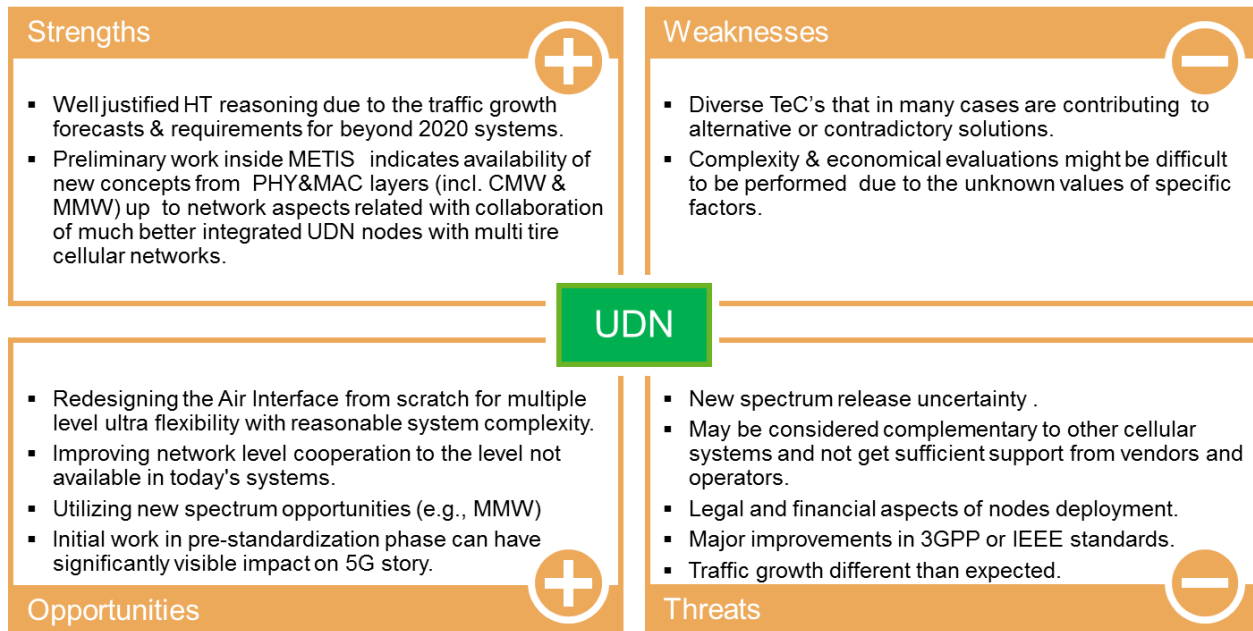

Figure 2-8: SWOT analysis of HT UDN.

### 2.4.3 Test cases addressed by UDN

All the TCs that are addressing challenges related with high data volumes and high data rates are relevant for HT UDN. These TCs are TC1 (Virtual reality), TC2 (Dense urban information society), TC3 (Shopping mall), TC4 (Stadium), TC6 (Traffic jam) and TC9 (Open air festival). In Annex, Section 7, additional information regarding each of the TCs is given. TC1 is the most challenging for indoor UDN deployments, where Gbps of user data rates are expected and the data volume per user equals 36 TB per month. Equally important is TC2 as a very general TC for e.g. public cloud services in urban dense environment. Because of comparable requirements w.r.t. user data rates and traffic volume TC3, TC4, TC6 and TC9 could be listed as specific deployments of more general TC2 (differences in user mobility or network infrastructure availability). Experienced user data rates reach up to 300 Mbps with data volumes equalling 0.5 TB per month combined with huge number of users, up to 200.000 per km<sup>2</sup>. One of the options for TC6 and TC9 to be solved is further network densification.

## 2.5 Ultra-Reliable Communication (URC)

### 2.5.1 Description of the HT

Despite the large proliferation within the last two decades, commercial wireless and mobile technologies have not attained the stage in which connectivity is guaranteed almost 100% of the time. The reason is that the commercial wireless technologies are designed to offer relatively good connectivity most of the time, but offer almost zero data rate in areas with poor coverage, under excessive interference or in a situation in which the network resources are overloaded. On the other hand, wireless technology continues to enter into new areas of use and an increasing number of services will start to depend critically on the availability of wireless link that offers certain communication quality, in terms of rate, latency, or another Quality of Service (QoS) parameter. Examples include:

- Cloud-computing services with defined minimal rate and/or maximal latency,
- Large-scale distributed cyber-physical systems for e. g. industrial control,





- Interconnected vehicles, communication between vehicles and the road infrastructure as well as the subjects proximate to the road, which is also in the focus of HT MN,
- Minimal communication requirements under emergency scenarios, such as minimal number of bytes that a wireless user/device is capable to send within a certain time.

In the description above the term *commercial* is emphasized in order to make a clear difference from wireless systems used by the military or law enforcement agencies, where ultra-reliability is achieved by a deliberate spectrum allocation, limited set of services, and completely different set of techno-economic constraints. The URC goals in the commercial systems cannot be achieved by simply changing a parameter in a system designed e.g. to offer a high speed local connection, but it should be part of the carefully crafted architecture as well as the positioning of the technology components within that architecture.

The HT URC will drive the METIS solutions towards enabling high degrees of reliability and availability. METIS aims at providing scalable and cost-efficient solutions for networks supporting services with very high requirements on availability and reliability, not present in today's systems.

METIS will meet the corresponding demand for the Internet of Things, in areas such as moving/vehicular networks, telematics, and automation that could benefit from wireless connectivity, but at present they are not using it due to insufficient reliability guarantees. On the other hand, METIS aims at providing wireless connectivity that, in addition to high peak rates, is capable to provide guarantees for sustained moderate rate that is available to the user greater than 99.999% of the time. Clearly, that is a new connectivity feature that should be coupled with a suitable service and business model.

The overall METIS technical goals addressed by this HT are:

- 10 to 100 times higher number of connected devices,
- 10 times longer battery life for low power devices,
- 5 times reduced E2E latency.

HT URC uses the following working **definition of reliability** as the probability that a certain amount of data to or from an end user device is successfully transmitted to another peer (e.g. Internet server, mobile device, and sensor) within a predefined time frame, i.e. before a certain deadline expires. Based on the latency requirements, the problems dealt with in URC can be segmented into two clusters:

- **URC over a long term (URC-L):** Problems that require minimal rate over a longer period (greater than 10 ms), such as minimal connectivity in emergency communications, minimal rate for a connection to a public cloud in a densely populated area, etc.
- **URC in a short term (URC-S):** Problems with very stringent latency requirements (at least 10 ms), such as vehicles communicating at a crossroad, teleprotection in smart grid, etc.

We introduce an additional URC cluster, termed **URC for emergency (URC-E)**, addressing the problem of minimal connectivity under emergency or damaged infrastructure. This problem logically belongs to URC-L, but it is treated separately due to the specificity of the scenario and the target test case.

As a part of the problem analysis, *five ReLiability Aspects (RLAs)* have been identified:

- RLA1. Decreased power of the useful signal.
- RLA2. Increased uncontrollable interference.
- RLA3. Resource depletion due to competing devices.
- RLA4. Protocol reliability mismatch.
- RLA5. Equipment failure

The higher the grade of a reliability aspect in a given scenarios, the more likely is that it can challenge the system towards achieving high reliability in that scenario. For example, RLA1 related to the propagation and received signal strength, will be critical in TC10 (emergency communications), while RF3 could be dominant in TC2 where lot of proximate users are trying to access the public cloud through the same part of the infrastructure. More detailed discussion on the reliability aspects is given in the Annex, Section 8.2.

As a part of the solution to different types of URC problems, the concept of *reliable service composition* has been introduced and is motivated as follows. URC assumes that a certain guarantee of some of the service parameters is of paramount importance. If the reliability requirement is stated rigidly, e.g. “*transfer of data packets that have at most B bytes with a delay less than L seconds in 99% of the attempts*”, then there is a clear criterion to decide whether the reliability requirement is met or not. However, the real question from the service viewpoint is: *Does the service need to fail whenever the reliability requirement is not met?* This is the entry point for reliable service composition: we would like to allow for a graceful degradation of the service, instead of making a binary decision “service available/not available”. The main idea behind reliable service composition is to set the framework for building protocols and transmission techniques that can adaptively switch to a lower grade of service (minimal connectivity) rather than failing the connection. More elaboration on the concept is given in Annex, Section 8.2.

The planned workflow of HT URC is depicted on Figure 2-9, which reflects the need for iteration in order to tune the TeCs to the reliability requirements, but also adjust the reliability requirements and KPIs as the understanding of the test case improves or a fundamental limit is encountered.

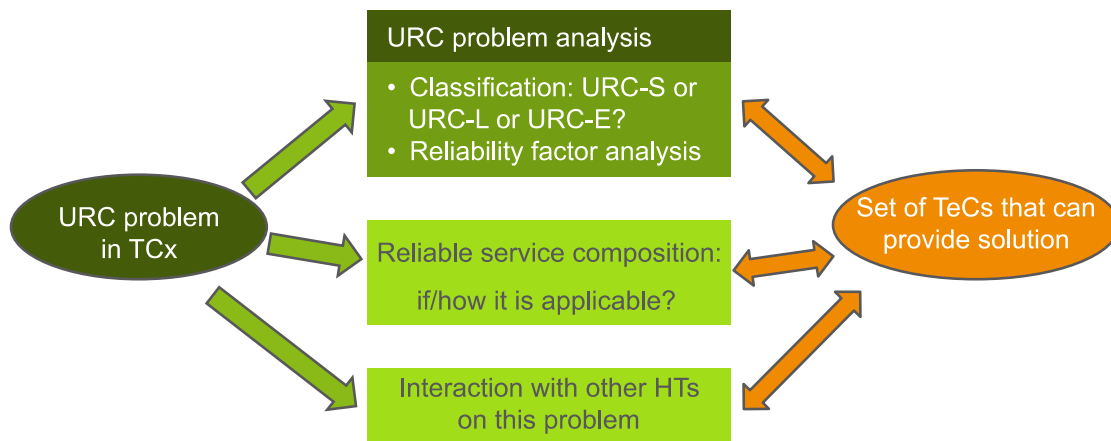

Figure 2-9: Workflow for HT URC.

### 2.5.2 SWOT Analysis

The SWOT analysis of HT URC is given in Figure 2-10. Considering that, the mainstream wireless standardization fora, such as 3GPP and IEEE, currently have a very limited activity (e.g. public safety in 3GPP LTE Release 12) that is explicitly addressing the issue of Ultra-Reliable Communication (URC), METIS is in a unique position to investigate the basic principles, requirements and limitations of for URC operation.

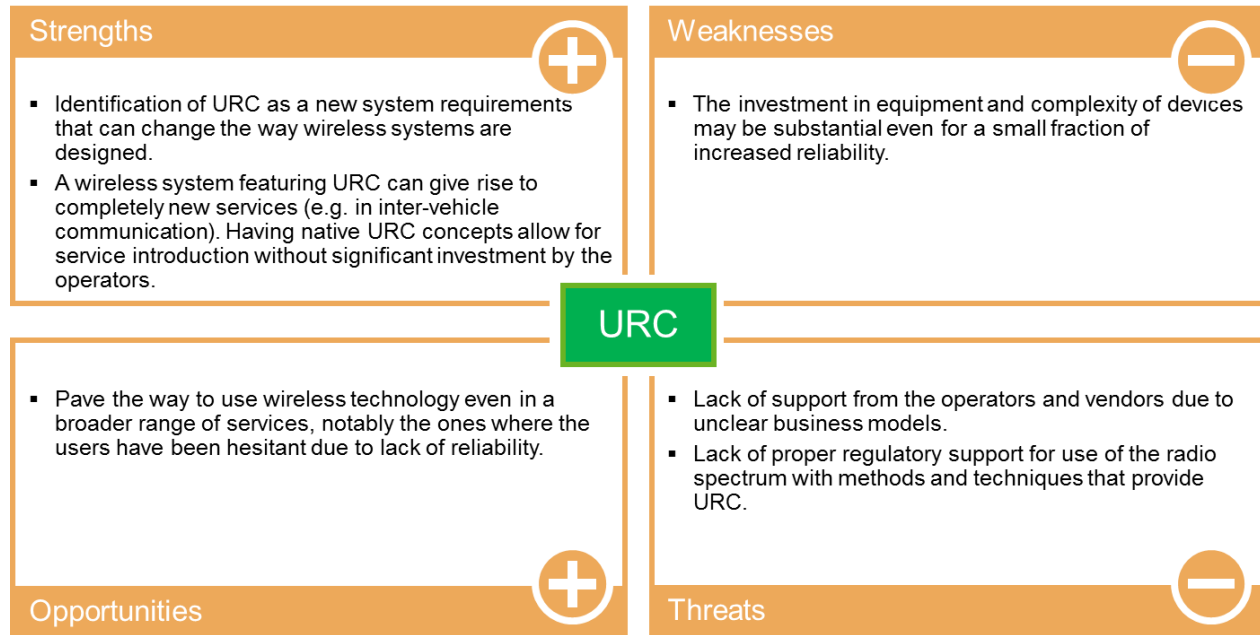

Figure 2-10: SWOT analysis of HT URC.

### 2.5.3 Test cases addressed by URC

The relevant TCs will be grouped according to the type of URC problem (URC-S, URC-L or URC-E) that emerges in the TC:

- URC-S: TC2 (Low-latency cloud access), TC5 (Teleprotection), TC8 (Real time remote computing), TC11 (Massive deployment of sensors and actuators), TC12 (Traffic efficiency and safety),
- URC-L: TC2, TC6 (Traffic jam), TC7 (Blind spot),
- URC-E: TC10 (Emergency communications),

More details on the TCs can be found in Annex, Section 7.

### 2.6 HTs and the METIS test cases

Table 2-1 summarizes the mapping of the HTs to the twelve METIS test cases [MET13-D11]. As can be noted, each test case is addressed by at least one HT. This mapping can be used to identify dependencies among HTs.



**Table 2-1: HTs and METIS test cases.**

	D2D	MMC	MN	UDN	URC
TC1: Virtual reality office				X	
TC2: Dense urban information society	X	X		X	X
TC3: Shopping mall	X	X		X	
TC4: Stadium	X			X	
TC5: Teleprotection in smart grid network		X			X
TC6: Traffic jam	X		X	X	X
TC7: Blind spots			X		X
TC8: Real-time remote computing for mobile terminals			X		X
TC9: Open air festival	X	X		X	
TC10: Emergency communications	X		X		X
TC11: Massive deployment of sensors and actuators		X			X
TC12: Traffic efficiency and safety	X	X	X		X



### 3 METIS 5G system concept

The METIS 5G system concept is achieved by first developing specific HT concepts, and then integrating them, plus complementary technology components, into an overall system concept that meets the METIS goals.

This section describes the first view of the overall METIS system concept and the five HTs concepts plus the supporting network architecture. It then shows how the METIS goals are addressed by the specific HT concepts. The section concludes by describing the next steps of the METIS system concept development.

#### 3.1 First view of the METIS 5G system concept

METIS envisions a user-centric 5G system concept that efficiently integrates:

- the support of MMC, MN and URC,
- the support of scalable data rates with range from very low to very high rates, and
- the support of scalable packet transmissions down to very low latencies,

using a system architecture that supports D2D communication, UDN deployments and evolved versions of existing systems to provide improved Quality of user Experience (QoE) and reliability to both consumers and devices/machines. To fulfil these requirements the system must be flexibly configurable to provide very different services, also dependent on time and location.

The use of higher frequency bands and new spectrum access schemes is one way to enable very high data rates. The coverage of systems operating in higher frequency bands may be limited, for example, to hot spots or dense areas. MMC and low latency on the other hand are required in wide area coverage. This leads to a system concept incorporating a number of air interfaces, each optimized for a specific set of use cases. The air interfaces including their protocol stacks will be configurable to a great extent in order to meet the diverging traffic demand of different applications. They will be integrated in smart and dynamic Software Defined Networks (SDN), [PWH13], which is a generalization of the Software-Defined Radio (SDR) concept [Mit92; E309-D24]. In contrast to existing cellular systems, sophisticated technologies such as ultra-dense access node deployments, massive MIMO, and multi-node coordination will be supported to achieve optimum performance. Frequency (FDD) and time (TDD) division duplex systems are expected to further coexist, while TDD-only operation is expected to become more widely used in higher frequency bands. Full duplex is under investigation, but its use will probably be restricted to low-power radio nodes, e.g. for indoor and outdoor small cell applications. Evolved versions of existing communication systems need to be integrated.

The METIS concept includes in particular nomadic and moving radio nodes (installed e.g. at cars and trains or even user devices) that can provide connectivity to users in their proximity and increase data rates by reducing the distance to the nearest access node. For moving networks assumption is made that more sophisticated MIMO solutions can be implemented in a vehicle node, making massive MIMO feasible.

Finally METIS foresees a new generation of dynamic Radio Access Networks (RAN), referred to as RAN 2.0. Following an analogy with the Web 2.0 concept, in RAN 2.0 the user devices can become active entities of the network, in addition to existing network nodes. This is a new paradigm of wireless networking in which user devices will temporarily take over the role of access nodes for other users e.g. to guarantee the ubiquity of high quality services. This multi-hop solution opens the door for an interconnection of devices that collaborates within a group of users they trust searching for mutual benefit, similar to a social network. RAN 2.0 implies a flat

architecture from service point of view resulting in low latency. It is also accompanied by an agile infrastructure support, since unplanned and smart coordinated setup of networks is expected under this service/user-centric model. Finally, RAN 2.0 also entails a different distribution of core functions that can be executed in any node depending on its hardware and software capabilities.

### 3.1.1 METIS network architecture

The new generation of RAN networks envisaged in METIS need to efficiently handle multiple layers and a variety of air interfaces in the access and the backhaul domains. They have to control and cope with the dynamics of traffic, user behaviour, and active nodes involved, and need to be able to differentiate a larger variety of QoS characteristics such as ultra-low latency traffic, ultra-reliable communications, broadcast traffic etc. This network control will be transparent for the user. SDN, Network Function Virtualization (NFV) [ETSI13], and Self-Organizing Network (SON) technologies [3GPP13-36300; 3GPP11-36902], will play an important role in the implementation and control of the METIS network nodes, in particular to improve scalability and reliability as shown later in this document with respect to achievement of METIS goals.

The generic METIS 5G network architecture as sketched in Figure 3-1 must accommodate a number of technical enablers and communication paradigms while taking into account existing and emerging evolutionary and revolutionary architectural trends. The network topology will comprise various flavours of Cloud-RAN (C-RAN) [NGMN13], traditional access nodes as well as new virtual access nodes where the fixed-cell concept disappears in favour of device-centric communications.

Moreover, 5G network architecture will also be scenario and use-case specific, e.g. it may be different in areas with low user density compared to deployments in ultra-dense areas, such as Mega-Cities. In this sense, METIS scenarios [MET13-D11] will be used to provide specific and realistic design approaches for architecture development.

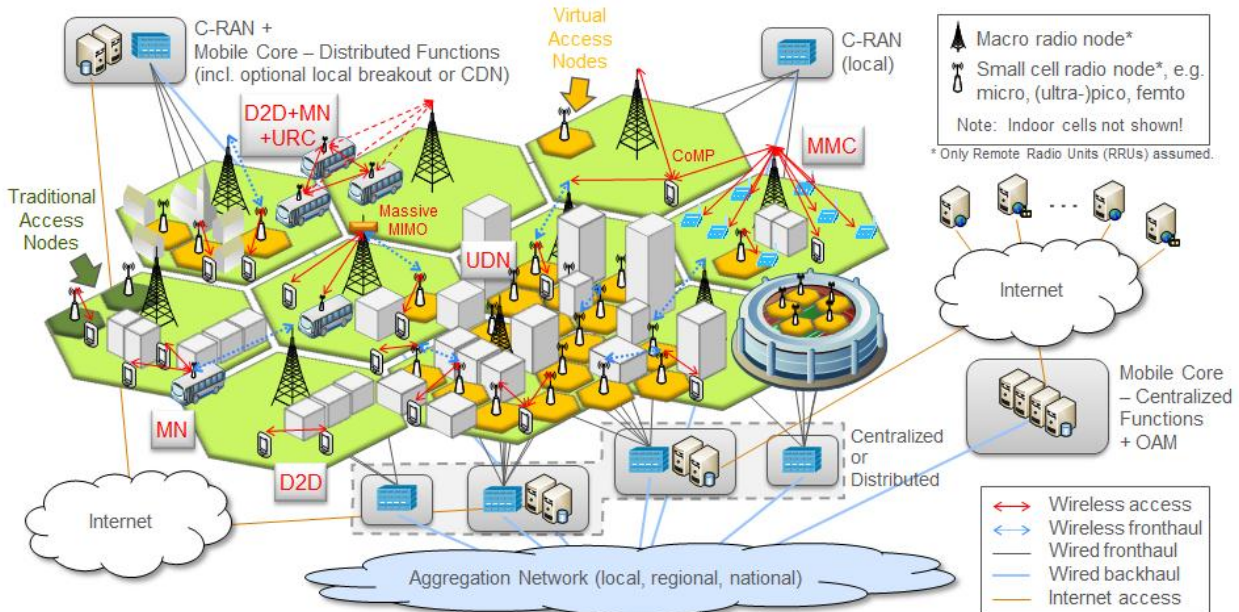

Figure 3-1: Generic METIS 5G network architecture (high-level view).



Implementation of radio network and service functions in C-RAN environments will simplify the mapping of SDN and NFV features (known from core function virtualization in data centres) to the RAN. It also increases flexibility with respect to integration of decentralized core functions in C-RAN processing units like local mobility management, local breakouts as well as Content Delivery Networks (CDNs) with caching capabilities [WCT+14]. Due to centralized processing and minimum delay among baseband processing units (BBUs) it allows simplified clustering of cells for joint RRM and interference coordination (including CoMP).

Dependent on network infrastructure availability of the Mobile Network Operator (MNO) and delay limitations set on back-/fronthaul links<sup>1</sup>, e.g. by CoMP schemes, C-RANs can be deployed in a distributed or more centralized way, which differentiate especially in the number of contained BBUs (realizable via virtual machines on general purpose processors, probably with support of HW accelerators for dedicated PHY computing tasks). Nevertheless, the BBU number of a local C-RAN can be also high in case of UDN, e.g. for a stadium environment.

Especially for operators with both fixed and mobile network infrastructure, cost reduction in future deployment stages is of great importance. For reuse of common network infrastructure on transport and access layer (Fixed-Mobile Convergence (FMC)) again SDN/NFV is seen as the key enabler [TAZ+13; COM13-D31] additionally allowing multi-operator network infrastructure and resource sharing in cost-optimized way. At the end, the definition and integration of joint core functionalities is seen as one of the next steps towards FMC networks [COM13-D31].

## 3.2 HT concepts

Each HT addresses a subset of the overall METIS technical goals which will be described in detail in Section 3.3. By integrating the relevant TeCs from WPs each HT builds a specific HT concept comprising new functionalities. This is shown in detail for each of the five HTs, referencing results of the work currently done in the WPs. The WPs researching the TeCs in METIS are WP2: Radio link concepts, WP3: Multi-node/multi-antenna transmission, WP4: Multi-layer/multi-RAT networks, and WP5: Spectrum [METIS14]. The detailed descriptions of the specific HT concepts allow then to identify the commonalities among them, which will be taken into account in their further integration towards the overall METIS system concept.

### 3.2.1 D2D

Direct D2D communication between wireless devices (mobile as well as stationary) is a corner stone of the METIS 5G concept which can improve the overall system performance and support new emerging services. METIS aims to integrate direct D2D modes as part of the overall mobile and wireless communication system from the beginning.

Considering the requirements from different TCs, D2D-related technical challenges raise at least following questions:

- How to enable an efficient discovery of devices in proximity?
- How to increase the throughput and coverage of D2D links without introducing extra power consumption and signalling overhead?
- How to select the most appropriate communication mode (i.e. direct D2D communication or infrastructure communication mode) in case of different users/services on different

---

<sup>1</sup> Backhaul is denoted as the link between aggregation (alternatively core) network and BBU of the radio node. The fronthaul is denoted as the link between BBU and Radio Remote Unit (RRU). This denotation is valid also for the C-RAN case [NGMN13].

bands with usage of different RATs? On which time-scale should mode selection ideally be performed?

- Which simple resource allocation schemes among D2D users and also between D2D and regular cellular users can be applied, especially considering the increased number of connections?
- Which solutions in both air interface and system level are possible to efficiently reduce the radio link latency which is one of the major benefits of D2D communication?
- How to optimally handle D2D communication when users are moving?
- How to handle the coexistence issue especially considering a large amount of connected devices, coexistence among D2D pair/groups and also coexistences between D2D communication and regular cellular communication?
- How to support lawful interception in order to meet regulatory requirements?
- Operating D2D in power efficient way, especially considering the cellular communication and D2D communication can use different carriers/bands.

Taking into account the technical challenges, the initial METIS D2D concept is illustrated in Figure 3-2. From the figure it can be observed that the direct D2D communication is controlled by the network and the D2D data is delivered among local devices. Within the link between local devices, it is also possible to include D2D related control information especially considering the D2D relay scenario.

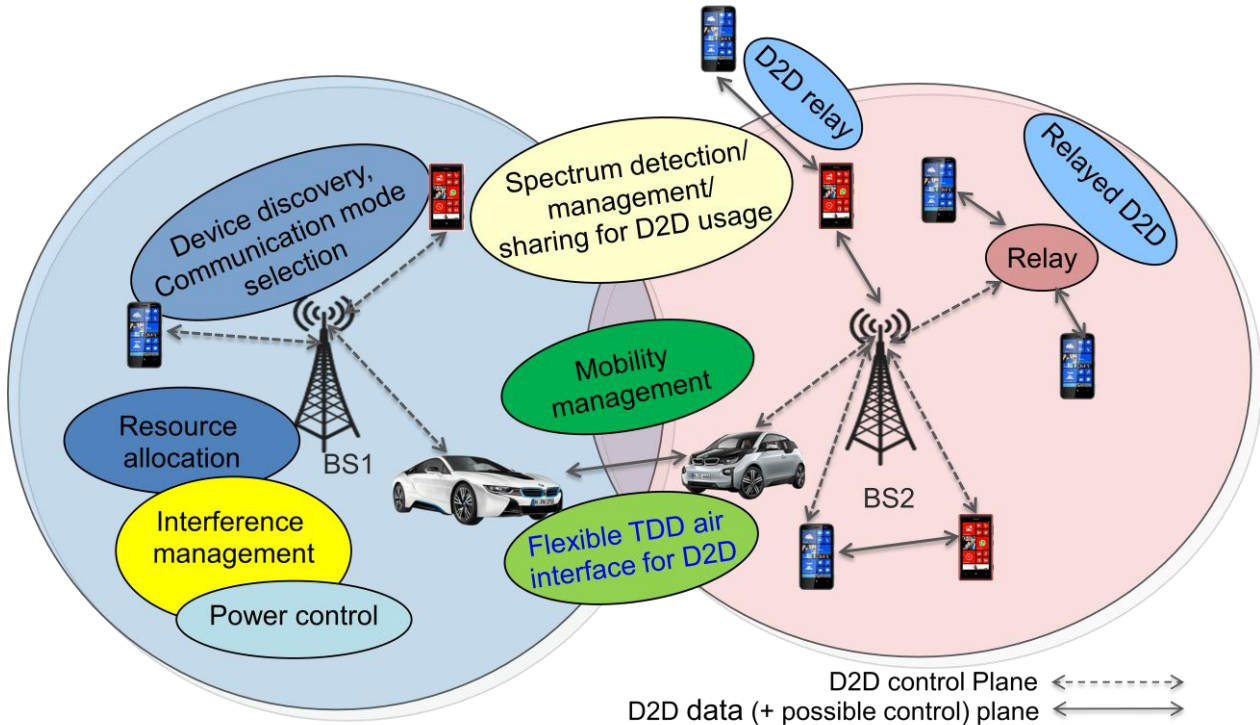

Figure 3-2: METIS HT D2D concept.

As indicated in Figure 3-2, the pillar building blocks of the initial D2D concept include:





- Flexible TDD air interface

In air interface management, a set of different configurations for different modes of operation are considered to allow the air interface to be individually configured according to actual system conditions and service requests as studied in WP2 (TeCC#4 Air interface management and advanced link adaptation). Appropriate metrics are developed which enable quick decisions on the selection of the most suitable configuration. Changing configurations should be achieved simply by adapting the parameter set. If the involved devices are with low mobility, a TDD based air interface (WP2 TeCC#1) composing of a scalable frame structure enables cost-efficient local communication. Due to the support of local communication, it can be easily applied to D2D use cases. Ongoing research topics cover dynamic partitioning of UL/DL periods in TDD mode to account for the potential highly asymmetric traffic. However, if the devices are with higher speed, air interface designed for moving networks and V2X communications (WP2: TeCC#6) should be used to support local V2X direct communication. Since the quality of transmission strongly depends on the proper knowledge of the radio channel, the research embraces novel channel estimation techniques for highly time-variant channels and channel prediction. In addition, with WP2 TeCC#2 (signalling for MMC) development of an optimized signalling structure meeting the main requirements of MMC: low cost, low power, small data packets to transmit. This is designed to extend the coverage of MMC via D2D communication. A more detailed description of these WP2 TeCs can be found in [MET14-D2.3]. Within METIS, the potential usage of FDD for D2D communication is also under investigation. However, one clear drawback for that is the potential high implementation complexity and related cost issues, in addition to the requirements on the available spectrum (e.g. paired spectrum required for FDD).

- D2D device discovery

Efficient network assisted D2D discovery, which is used to determine the proximity between devices and the potential to establish a direct D2D link, is a key element in order to enable D2D communication. A unified discovery framework (WP4 T4.1-TeC2) is under investigation by taking into account the benefits from both UE-based and NW-based schemes. A certain discovery resource pattern is defined by the adjustable size of a resource pool including a group of Discovery Resources (DR), where discovery resource is the resource unit to be used for transmitting one discovery message. The pattern is configurable depending on the scenarios in terms of different levels of network assistance. For example in fully NW-assisted cases, each resource pool contains one DR, while in fully UE-based discovery cases the resource pool is composed of all the DRs available for the discovery. Methods for adjusting the size of the resource pool and grouping UEs to achieve high resource reuse are investigated to increase the discovery efficiency. A more detailed description of these WP4 TeCs can be found in [MET13-D41].

- Communication mode selection

After devices find out that they are close to each other, the next step is to consider whether the D2D link should be established or not. Mode selection is a mechanism which decides whether a D2D candidate pair should communicate via regular cellular communication mode or direct D2D communication mode. Both distributed Channel State Information (CSI) based and location based mode selection schemes are proposed (WP4 T4.1-TeC3) with the assumption that D2D is running within cellular band.



- Distributed CSI-based mode selection: only depends on the information that is specific to the D2D pair. It is assumed that large scale fading between the D2D transmitter and receiver and between the D2D transmitter and the Base Station (BS) is available. The direct D2D communication mode is selected if the hypothetical capacity values corresponding to the useful links are higher than the hypothetical capacity values of the interfering links plus a  $\Delta$  value (a tuneable system parameter measured in bit/s/Hz).
- Location based mode selection, based on users' location information the BS estimates the distances between candidate D2D users and between each of the candidate users and the BS. The distances are then mapped to corresponding received signal powers by utilizing appropriate path loss model. Based on the distance and the estimated path loss, the BS decides whether the users can transmit using a direct link or the link via the BS [MET13-D41].
- Joint mode selection and scheduling is for direct D2D (WP4 T4.1-TeC4). A more detailed description of the WP4 TeCs can be found in [MET13-D41].

- Interference management

Interference can be present between D2D pairs and between the D2D link and the cellular link. How to efficiently reduce the interference to improve e.g. link throughput is a topic under investigation. Clearly the most straightforward way to reduce interference is to allocate orthogonal resources to different links. Within METIS, resource allocation covering both single cell and multi-cell approaches are considered (WP4 T4.1-TeC4). Combined resource allocation and mode selection are considered in the multi-cell resource allocation case. Further for location based resource allocation, the BS uses the distances between the users and between the users and the BS to estimate the path losses and the Signal-to-Interference Ratio (SIR) for users sharing the same resources, accordingly. The selection of the best candidate for resource sharing is performed based on the distance maximization. On top of centralized resource allocation as described above, distributed resource allocation is under investigation as well for example in WP3 T3.2 decentralized interference aware scheduling for D2D was studied [MET13-D31]. In addition, power control is considered, for example distributed iterative power control exploiting covariance measurements performed by D2D receivers ((fast) RSSI type of measurements) and fed back in a distributed fashion to the respective transmitters to adjust transmit powers. Moreover, advanced interference suppressing receivers such as MIMO IRC/MMSE receivers and so on can be utilized to reduce the interference as well. Most of the interference management topics are studied in WP4 [MET13-D41].

- Mobility management

Due to the introduction of direct D2D communication as a new transmission mode, an optimized mobility management procedure, e.g. by defining a new D2D handover criterion in addition to the traditional cellular handover criteria, WP4 T4.2-TeC8 (D2D handover schemes for mobility management) can bring benefits of improving the overall system performance in terms of signalling overhead and latency. In addition, the D2D UEs can be clustered in a minimum number of BSs in order to provide better user experience, especially considering latency [MET13-D41].

- D2D relay and relayed D2D



Different forms of D2D relays can be supported based on METIS solutions. For D2D relay (i.e. UE-to-NW relay), one example is the multiple-stream based relay where communication from a multi-antenna BS to a multi-antenna UE, assisted by other multi-antenna UEs acting as relay nodes, is considered. In addition, relayed D2D (i.e. UE-relay station (RS)-UE) is also under investigation where two or more communication device pairs are assisted by a relay station as illustrated in Figure 3-2. The research topics include distributed coding for the multiple access multiple relay channel, bi-directional relay with non-orthogonal multiple access, closed-loop and open-loop techniques in a network with D2D relaying. In addition, underlay D2D communication with physical layer network coding is under investigation as well. More details on relay related TeCs can be found in [MET13-D31].

- Spectrum detection/management/sharing

Identifying suitable spectrum for D2D operation can bring significant performance improvement to the whole system. Taking into account the requirements from D2D related TCs, suitable spectrum can be identified after the analysis of pros and cons, possible way of spectrum sharing, negotiation with other entities and other necessary steps. In overlay in-band D2D operation (where D2D and regular cellular communications are sharing the same resource) a fundamental issue is how to divide the spectrum between the cellular and D2D transmissions. Also, mode selection in overlay D2D (where dedicated resource for D2D usage is defined) can take advantage of the fact that only D2D users transmit in the D2D part of the spectrum. A potential D2D user measures the D2D spectrum and uses a threshold-based test (e.g. energy detection) to decide whether it transmits in D2D mode or in infrastructure mode. In this way, the mode selection becomes completely decentralized eliminating signalling overhead between the D2D users and BS. The impact of RF impairments is also incorporated into the study. Details on spectrum management and sharing TeCs can be found in [MET13-D51].

It should be noted that comparing with the current ongoing D2D work in 3GPP, [3GPP13-22803; 3GPP13-22278; 3GPP14-23703; 3GPP13-36843], the METIS D2D concept brings significant improvement due to the introduced novel TeCs. One of the major differences is that with the current agreement of 3GPP, allowing only broadcast type of operation and providing no support of L1/L2 feedback, link adaption etc. There is no such restriction in METIS and there are TeCs utilizing feedback information e.g. CSI for power control. Considering air interface, METIS is proposing to adopt a configurable air interface in order to best meet the requirements, and a scalable frame structure allows adapting framing times and symbol durations. Also D2D relay, UE-UE relay has been mentioned in [3GPP13-22803], but detailed technical solution has not been discussed and will not be discussed in Rel-12 time frame. In addition UE-RS-UE employing various multi-stream techniques has not been considered at all in 3GPP so far. In addition, at network level, different TeCs have been introduced in order to support advanced interference management e.g. location based resource allocation, iterative power control etc. and also mobility management to maximize the system performance based on both cellular and D2D operation. These features are clearly not considered in the 3GPP studies. Furthermore, how to detect and exploit the available spectrum in dedicated or shared way is a completely new topic as well.

It should be observed that the Figure 3-2 is the initial high level concept proposal and the concept development will continue within the remaining METIS project run time. At this point, one of the major issues which has not been discussed is the D2D operation between devices from different operators which is quite important especially considering the commercial use



cases, for example in TC12. Also, necessary architecture support needs to be addressed in the next phase of METIS work. Consider regulatory requirements, another important topic is lawful interception which has not been well studied so far and it is expected that it will impact the D2D system design as well.

It is worth to point out the possible links to other HTs for example UDN, MN, URC, and MMC. From the air interface point of view, one of the radio air interface configurations is a TDD-based flexible air interface (WP2: TeCC#1) which is designed for UDN as well. Also when considering high mobility devices including e.g. vehicle type of devices, there are quite many common TeCs shared between HTs D2D and MN. With regard to the connection to HT URC, D2D is one of the most efficient methods to increase the link reliability together with reduced latency due to the short communication distance. In addition, it can be used to increase the reliability level as diversity path (so far that topic has not been studied in METIS). For MMC, one way to extend the coverage is to use the normal cellular devices as relays, i.e. applying D2D links between normal cellular devices and MMC devices [MET14-D23].

### **3.2.2 MMC**

#### **3.2.2.1 Radio Access for MMC**

To achieve the METIS goals related to MMC, as outlined in Section 2.3, three different types of radio access can be envisioned. First, the *direct access* depicted in Figure 3-3 a), in which devices transmit directly to the access node. The benefit of this scheme is that it requires no planning when deploying devices, given that access nodes provide full macro coverage. Another advantage is the provided flexibility in terms of mobility management particularly for non-static devices. The drawback might be the coverage aspect; for low-complexity devices with low output power constraint extra attention is needed to reach the coverage KPI in uplink.

Second, in Figure 3-3b), the *accumulation/aggregation point type of access* is depicted. In this case, traffic from the devices in the proximity is accumulated in a local node before being sent to the macro access node. The accumulation point can either be a relay, a service dedicated gateway, a smart phone connecting personal electronic devices, or a dynamically selected device acting temporarily as the group/cluster head. For this scheme, a varying range of data processing could be applied. From forwarding the data as it is (as a relay), to accumulating data (in order to have few but larger transmissions to the access node), or even doing processing in the accumulation point (in which case only the relevant and processed data is forwarded to the macro access node). With the use of accumulation point access, deep indoor penetration can be more easily obtained.

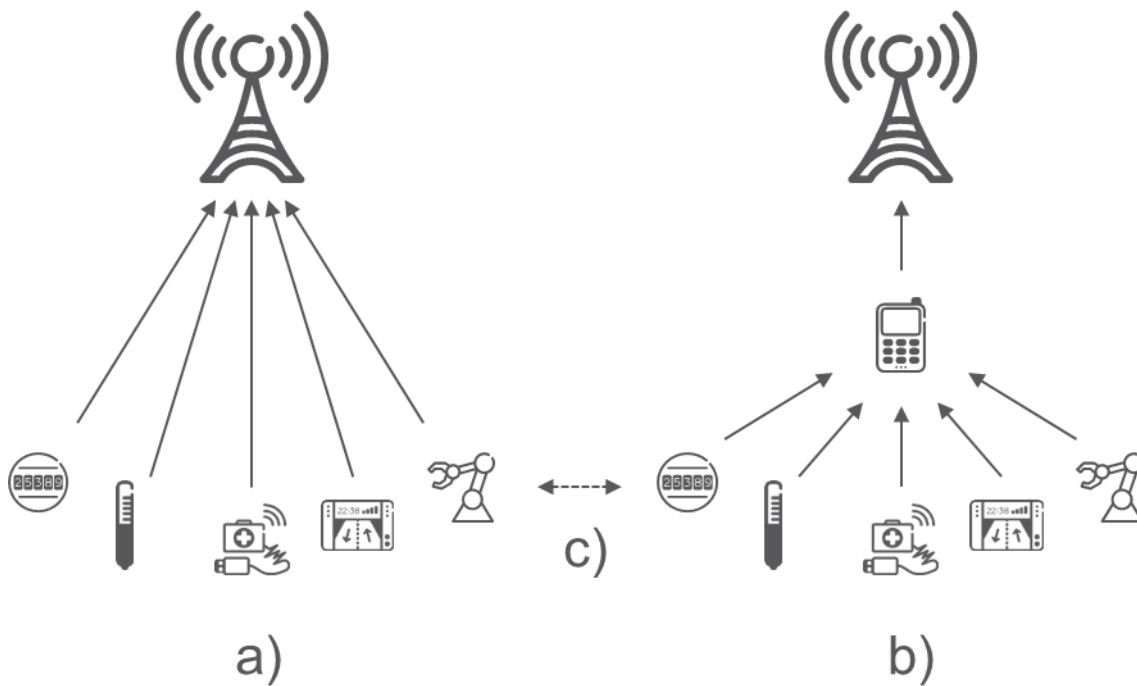

**Figure 3-3: HT MMC illustrated in the case of a) direct access, b) accumulation point access, and c) M2M access.**

Third, in Figure 3-3 c) the case of direct M2M communication between devices is depicted (M2M is the notation for MMC D2D communication). Although the focus is on very low bit rates and delay tolerant traffic rather than very high bit rates and tight delay budgets, this case naturally inherits most technical solutions from the D2D communication HT. One key difference of M2M communication relative to D2D communication is the requirement for very high protocol efficiency (i.e. very low signalling overhead) and the requirement for long device battery life. For the latter requirement, M2M transmissions would be very beneficial in the case where the device is in bad or unstable coverage area and/or is power limited, i.e. the device has reached the maximum transmit power level. In most other cases, the major factor on the device battery life is the required on-time and the base power consumption of the power amplifier. Because of these two reasons, the normal D2D setup process is not feasible for M2M communication, at least not for battery-operated devices. Therefore, more long term and static setup would be required for M2M communication compared to D2D communication. That is, for each M2M transmission of very few bytes it is not feasible to repeat the full D2D setup procedure including; 1) identifying whether the traffic is E2E, 2) device discovery and link quality analysis, 3) determining if the M2M link quality is good enough such that a direct M2M link would be favourable to routing the traffic via the access node, and 4) determining whether system resources should be reused locally or if dedicated resources should be used for the M2M link. Expressed differently, if M2M traffic is found not to be applicable in a certain case, the above procedures shall be designed in such a way that they only introduce an almost-negligible increase in signalling overhead and battery consumption.

Note that the use for M2M will be very service-type dependent, i.e. some services will never have the need for M2M transmissions whereas in other cases it may be the main form of communication. For example, in the case where the accumulation point is a group head, Figure



3-3 b), a sensor network assigns one sensor to act as a group head to be the contact point to the access node. This assignment can be, e.g. based on which device has the most favourable radio conditions in the group toward the access node or can simply be based on a rotating scheduling scheme in order to minimize overall power consumption. An essential building block for this work is of course M2M communication.

It is worth noting that the three above-mentioned access schemes are not exclusive and can be applied together in hybrid scenarios, e.g. dependent on the service and application requirements.

A technical challenge for MMC is further to support a very wide range of devices with different requirements. That is, although the requirements on bitrates and data volumes will in general be far below those of human-centric traffic there can still be large variations in e.g. reliability, inter-arrival times, mobility, latency etc. Naturally different access types in Figure 3-3 will be beneficial in different cases but it can potentially be challenging to have an air interface which is flexible to incorporate them all.

### **3.2.2.2 Research Activities for MMC**

The MMC concept is built up by a combination of the innovative and new research activities in METIS (Technology Components) and more basic system design choices.

The most promising Technology Components (TeCs) for MMC are related to:

- Coded quasi-orthogonal random access techniques. [WP2 TeCs 2.2, 11.1.3, 12.1.3]
  - Increased number of devices due to increased code space.
  - Multi-user detection with compressed sensing, and successive interference cancellation used as enablers.
- Coded access reservation using successive interference cancellation over access time slots providing higher degree of user multiplexing and load. [WP2 TeC 12.1.1]
- Hybrid access scheme: Steering of periodic traffic to semi-persistent scheduling. [WP2 TeC 2.1]
  - Reduced control signalling related to scheduling grants.
- Techniques for relaxing UL synchronization requirements. [WP2 TeC 8.1 and 8.2]
  - Reducing control signalling and improving battery life of devices.
- Relay-assisted underlay MMC links. Resource reuse by means of interference cancellation for short-range device-to-relay communication (see, Figure 3-3b) ). [WP2 TeC 2.3]
  - Enabling a larger number of devices that can access to the network.
- Software configurable air interface depending on context or service. [WP2 TeC 4.2]
  - Waveform, frame structure, MAC, (re)transmission scheme, coding and modulation.
- UDN, taking advantage of dense deployments for MMC. [WP2 TeCC#1]
  - Narrow band-width support for MMC within the UDN framework.
  - Enabling large numbers of connected devices in near environments.



- Context-based device grouping and signalling and configurable network optimizations
  - Tailoring in geographical or time region. [WP4 T4.3-TeC1-A1]
  - Compression of redundant data to reduce bits over the air. [WP4 T4.2-TeC12]

More detailed technical descriptions of these solutions can be found in references [MET14-D23; MET13-D41] and a visual overview is presented below in Figure 3-4.

### **3.2.2.3 MMC concept**

The basic concept choices suitable for MMC and to incorporate the above TeCs are listed below:

- Time synchronous, i.e. time slotted access.
  - Since this is the working assumption of many of the technology components above.
- Preferably one common air interface supported by MMC devices independent of the radio access selection shown in Figure 3-3.
  - Provides simple planning, flexibility and economy of scale.
- Both connectionless and always-connected approaches should be supported.
  - In the connectionless approach, there is no user context stored on the network side and all required control plane data (such as, device ID and security) is transmitted alongside the user plane data (i.e. integrated control and data plane).
  - In the always-connected approach, the user context is stored more permanently on the network side and upon transmission of user plane data, only a reference to either the device ID or device specific resources is included.
  - Which of these approaches is optimal will depend on the type of application, mobility and the traffic characteristics. Therefore both approaches will be supported in order to be able to provide the optimal solution for the wide range of MMC applications.
- Both contention based transmission of data and access reservation should be supported.
  - Which of these schemes is the optimal will depend on the type of application and on the traffic characteristics. That is, for very small payloads contention based transmission will be favourable, whereas for larger payloads traditional access reservation to avoid collisions of user plane data is optimal. Therefore both schemes will have to be supported.
- For low cost devices half-duplex operation should be the working assumption
  - Whether to further use TDD or FDD is of less importance. (This depends on the trading cost for a duplex filter to the inter-cell interference among and UL-DL separation for FDD among other things).
- Licensed IMT spectrum access is preferred for MMC
  - Due to technical merits such as; guaranteed service in the future, controlled resource usage and interference management, being a realistic option to obtain spectrum below 1-2 GHz to provide good wide-area coverage, and enabling simple scheduled and quasi-orthogonal access.



- Unlicensed ISM spectrum access may however come to be considered on economical merits due to global harmonization giving the benefit of economy of scale plus no licensing costs.
- More device centric processing for mobility
  - In order to minimize frequent measurement reports and signalling overhead.

During the course of the project a number of additional research areas or aspects have been identified to be important for MMC. These are listed below:

- Further coverage improvements for low complexity devices.
- How MMC can piggy-back and benefit from UDN deployment.
- M2M specific requirements as compared to D2D communication as discussed above.
- Massive MIMO on the access node side as an enhanced coverage enabler.
- Optimized sleep mode solutions for battery operated devices.
- MMC mobility procedures with a minimum of signalling and measurements.
- Group head operation aspects.
- Connection establishment, i.e. connectionless or always-connected.
- Cost reduction by e.g. band-width or transmit power reduction techniques.

These areas can pose new interesting research opportunities and will be studied further during the continuation of the METIS work.



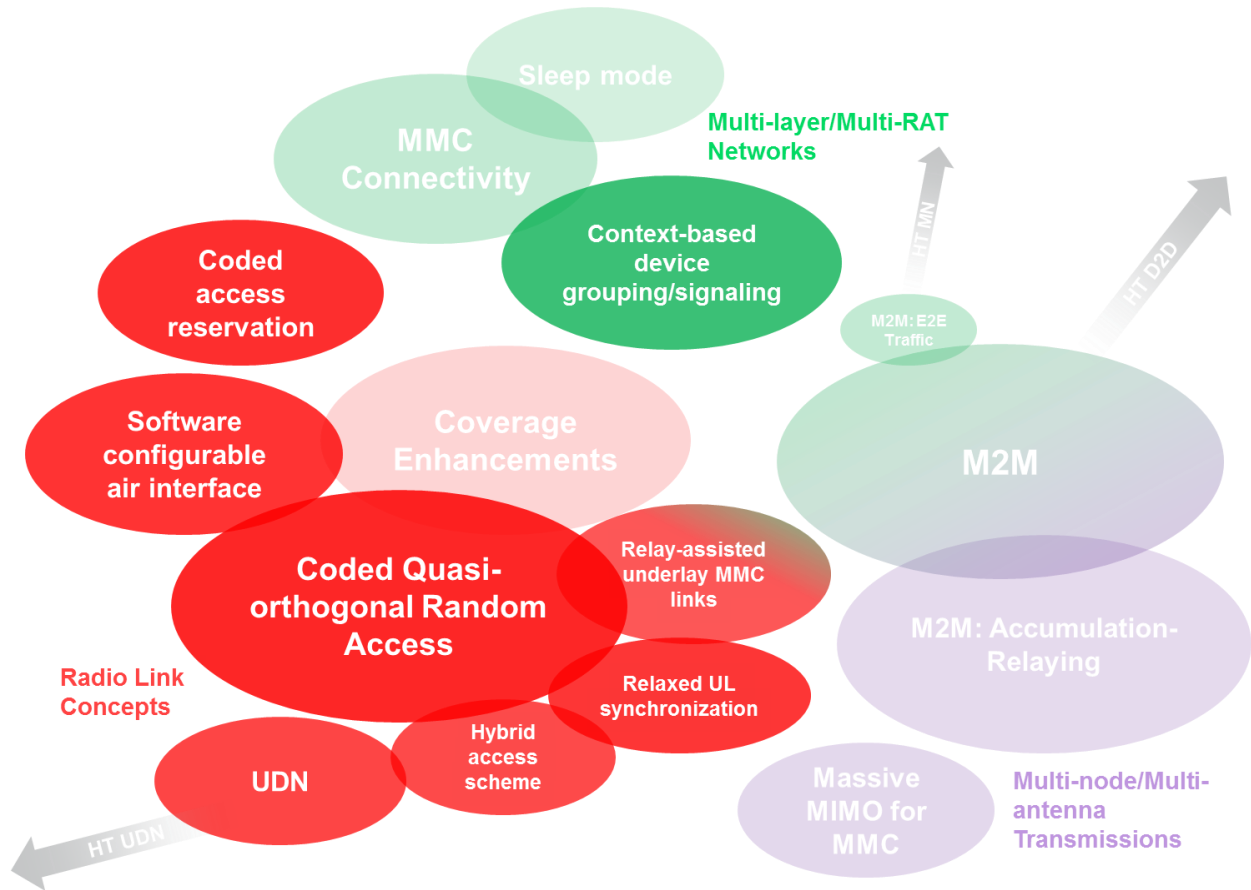

**Figure 3-4: MMC concept illustration. The size of concept components relate to the relevance for MMC and the opacity to the maturity level. Relations to other HTs are indicated by arrows.**

The MMC concept is schematically shown in Figure 3-4. For each concept component in the figure the size and opacity in the figure is illustrating the relevance and maturity for MMC. Arrows are further indicating the relationship to other HTs.

### 3.2.3 MN

The concept proposal for the HT MN extends across the three moving networks clusters, each of them addressing a different focus point or flavour of the system concept. While the MN-M cluster represents an evolutionary improvement of the existent technology addressing highly mobile scenarios, the MN-N and MN-V clusters introduce a paradigm shift in the usage of mobile communications. MN-N enlarges the role of future vehicles and transportation systems within mobile communication networks by becoming a part of the infrastructure. MN-V cluster, on the other hand, enables the provision of services of great societal impact such as road safety and traffic efficiency applications.

The system concept is based on a generic toolbox of fundamental high level components which address the main challenges posed by the mobility aspects.

- **MA1 – Link level performance in mobile channels**

- **New waveforms and channel equalization techniques** to improve the robustness against the Doppler shift.
- Advanced **channel coding, link adaptation and HARQ mechanisms** to exploit the presence of fast fading.
- **Multi-node and multi-antenna techniques** aimed at improving the user throughput and the system capacity while being robust to the imperfect channel knowledge that results from highly mobility.
- **MA2 – Handover and cell reselection**
  - **Handover prediction and optimization** in order to guarantee seamless connectivity and improved quality of service of mobile users and backhaul links of moving cells
  - **Cell reselection and handover management** (i.e. in-bound/out-bound mobility) in order to cope with the challenges posed by the densification of moving and nomadic cells in the case of highly mobile users.
- **MA3 – Management of nomadic and moving cells**
  - **Dynamic de-/activation of nomadic (moving) cells** to provide additional capabilities for energy saving and load balancing for the network.
  - **Interference management and advanced cooperative strategies** as enablers to provide diversity and capacity enhancement to the network based on the use of nomadic nodes.
- **MA4 – Enablers of mobile D2D**
  - **RRM and MAC techniques** to allow for satisfactory communication performance, provided limited or no CSI knowledge.
  - **Device and service discovery schemes** optimized for highly mobile devices by considering the time to discovery, the number of discoverable devices/services and the required signalling overhead.

Figure 3-5 depicts the relationship among the four mobility aspects to build the system concept of the HT MN. Note that spectrum management can be considered as a high level component that impacts all mobility aspects in the concept.

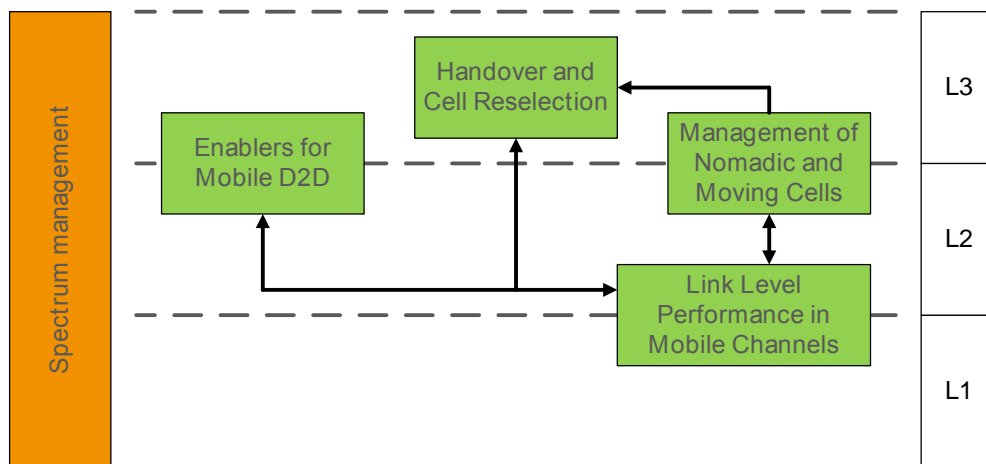

Figure 3-5: MN system concept based on mobility aspects.



In order to adapt the HT MN concept to each MN cluster a different set of mobility aspects and a combination of corresponding high-level components is suited (see Annex, Section 9.1 for more details). In the following the different flavours of the proposed concept are presented in detail:

### **3.2.3.1 MN for mobility-robust high-data rate communication links (MN-M)**

The main challenges of MN-M are covered MA1 – Link level performance in mobile channels, MA2 – Handover and cell reselection, and MA3 – Management of nomadic and moving cells, see Annex, Section 9.1.2 for more details. As a result, the concept revolves around link enhancements achieved at the physical layer, combined with efficient management mechanisms at the higher network layers.

The former can be achieved with the aid of novel waveforms, advanced modulation and coding schemes, and improved channel estimation and prediction techniques (investigated by partners in WP2), together with better exploitation of spatial diversity (investigated by partners in WP3). These techniques enable high mobility robustness and reduced coding/decoding latency, in-line with the key requirements and challenges posed by the MN-M cluster. In this sense, the framework for URC, developed in WP2, enables QoS control over the communication links and constitutes an interface to the radio resource management and medium access control schemes responsible for the efficient utilization of the radio resources in the network. Hereby, radio resource management schemes investigated in WP4 are adopted in the concept.

Handover management also plays a significant role in the provisioning of high-data rate and low latency communication links. Hence, handover optimization mechanisms, developed in WP4, are adopted in order to enable seamless and optimal connectivity. Interference management has been identified as another key aspect. Hereby, solutions for interference identification delivered by WP4 are incorporated into the system concept. Moreover, the utilization of context information could help increase the gains of the L2-L3 components considered in the concept. For example, trajectory prediction can be used as a basis for the selection of an appropriate access point and for QoS control such that the requirements posed by the MN-M cluster are satisfied.

Furthermore, the characteristics of the MN-M cluster lead to the necessity of certain spectrum management schemes in order to enable optimal spectrum utilization. To this end, a solution for the flexible spectrum utilization, developed in WP5, is incorporated in the concept. The aim of this component is to increase the probability of finding interference-free spectrum and, hence, provide better robustness for the communication links.

Figure 3-6 visualizes the high level structure of the concept for the MN-M cluster and shows the interactions between the different components. For a detailed description, please see Annex, Section 9.1.2.

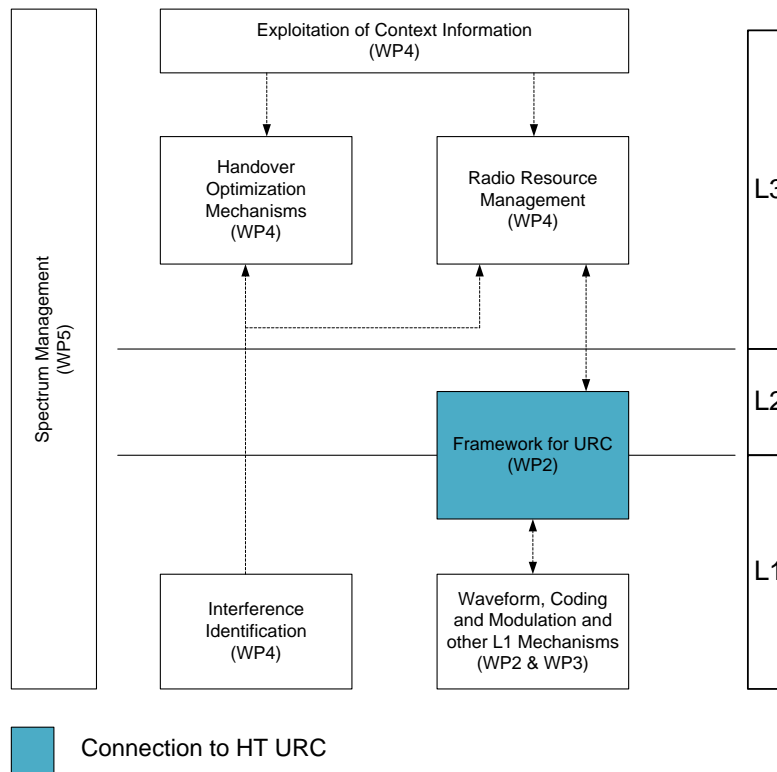

Figure 3-6: MN concept proposal – MN for mobility-robust high-data rate communication links.

### 3.2.3.2 MN for nomadic network nodes (MN-N)

The main challenges of MN-N are covered by MA2 – Handover and cell reselection, and MA3 – Management of nomadic and moving cells (see Annex, Section 9.1.3 for more details). In the context of MN-N, we extend the system concept of UDN and provide a tool that offers increased system capacity and coverage based on dynamic user and traffic demands. Although nomadic nodes are stationary in principle, the inherent uncertainty with regards to their availability (e.g. vehicular relay nodes) resembles a network that is “moving” or “movable” and, therefore, justifies its place within the HT MN.

Moreover, the MN-N cluster can serve as an enabler for HT URC with regards to Emergency communications (TC10). In particular, it can support URC-E (see Section 3.2.5) as the hardware available in nomadic nodes may be used to establish an ad-hoc wireless infrastructure when the conventional network infrastructure was damaged by a natural disaster. However, this would require a redefinition of their functionality and integration into the system, since the usual nomadic node operation assumes the availability of backhaul and infrastructure.

In the case of the MN-N cluster, the focus lies on solutions that can cope with the dynamic behaviour as well as the inherent uncertain availability of nomadic nodes. Therefore, the core part of TeCs focuses on management algorithms that identify coverage and capacity demands of UEs, which trigger the activation and de-activation of nomadic nodes. However, activation and de-activation of nomadic nodes have to be done carefully since a nomadic network is highly dynamic; not only are users moving and, therefore, the capacity and coverage demand is changing, but also the nomadic nodes themselves may not be always available. The availability of nomadic nodes – especially if they are mounted on vehicles – depends on battery constraints



and parking behaviour of the drivers, which depends on, e.g. day time and region. This requires very adaptive and very flexible management mechanisms taking also into account the network's overall energy consumption. Moreover, the activation of nomadic nodes has impact on inter-cell interference levels (when full frequency reuse along with inband operation being applied) which may negatively impact UEs that are nearby but not served by the activated nomadic nodes. Therefore, dynamic interference and radio resource management algorithms are key to coordinate the fixed heterogeneous network with the nomadic nodes. Besides that, the clustering of nomadic nodes allows for simplifying and facilitating node and interference management in such dynamic network. Due to the uncertain availability of nomadic cells, i.e. a nomadic node may become unavailable; a user could encounter handover decision even if the user is fully stationary. Hence, smart mobility management techniques for UEs are required that ensure seamless connectivity in the existence of such nomadic cells. The most important target here is to react fast upon arrival and departure of nomadic cells, while avoiding to be connected to a nomadic cell which would soon be unavailable. Since nomadic nodes may not always be connected to a wired backhaul, enhancement techniques for wireless backhaul links are essential to leverage the gains of nomadic networks. Such schemes significantly improve the capacity and reliability of the whole network, since backhaul link may be most of time the bottleneck in the end-to-end communications due to e.g. low alleviation. Interference alignment and cancellation schemes, CoMP techniques as well as dynamic resource allocation increase the robustness and throughput of wireless backhaul links of nomadic nodes. Similarly, advanced relaying schemes – such as two-way relaying – can be applied to nomadic nodes, which increase the user throughput and reliability of communication links in such a dynamic network. All these schemes depend on the availability of robust air-interfaces and waveforms which are developed in WP2. In principle, the same TeCs as used for UDN can also be used for this cluster; however, they need to be adapted in order to cope with a highly dynamic network including nomadic nodes.

In order to react fast enough to changes in the network, the key management components – such as (de-)activation, interference and clustering algorithms – as well as the backhaul link enhancement and clustering techniques rely on accurate interference information. Moreover, timely action of these schemes requires the prediction of interference. Sophisticated interference identification and prediction algorithms are needed that can extract information about the interference couplings also based on incomplete network knowledge. The prediction of the trajectory of the users as well as their traffic profile helps identify upcoming capacity and coverage demands. This is an important input to the nomadic node activation and deactivation schemes. New management interfaces are an important enabler to share the predicted data efficiently among the various network entities as well as among operators and service providers. This enables the practical implementation of centralized and decentralized data distribution schemes. Spectrum management requires the detection and selection of available spectrum for nomadic nodes. This is essential to enable smart spectrum coordination in order to decrease inter-cell interference. Moreover, a sufficient amount of spectrum needs to be available to allow for high-data rate backhaul links. Finally, the full potential of nomadic networks can only be leveraged by enabling multi-operator support.

Figure 3-7 illustrates a first version of the concept based on the high level solutions identified for the MN-N cluster.

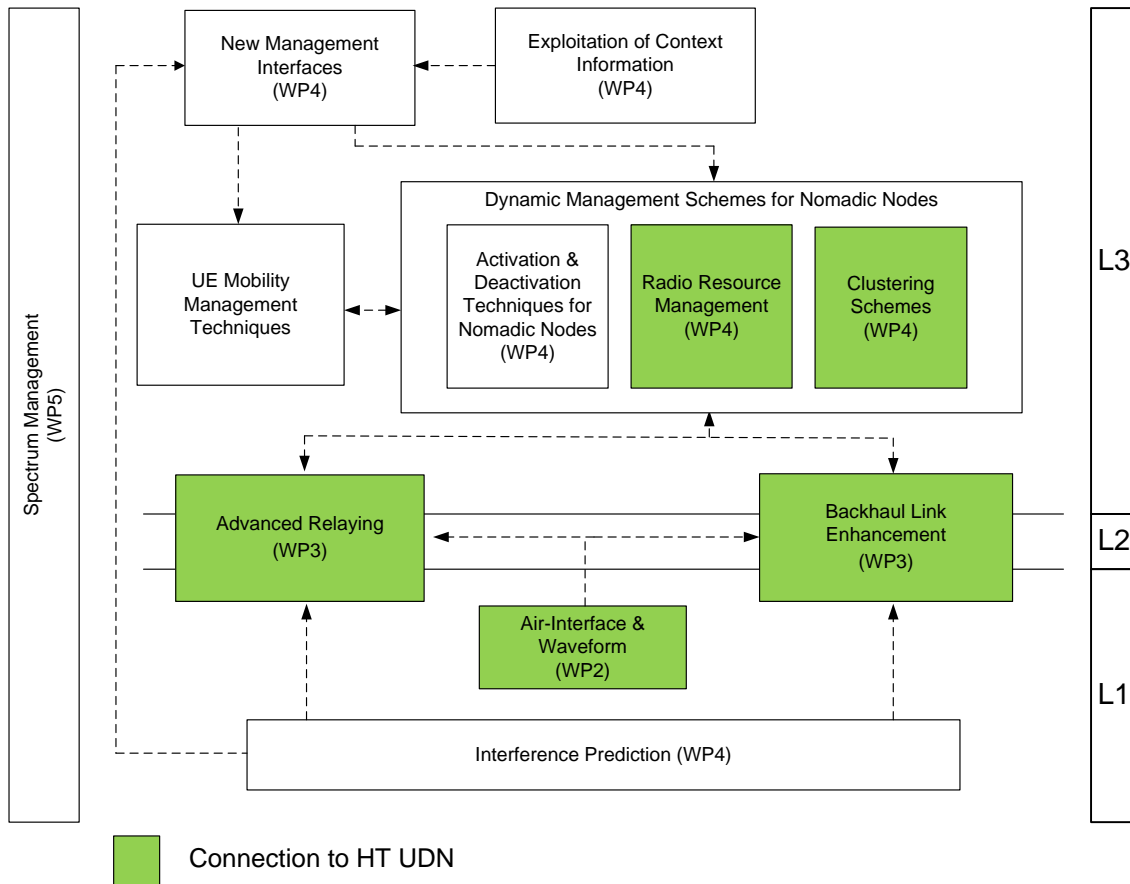

Figure 3-7: MN concept proposal – MN for nomadic network nodes.

### 3.2.3.3 MN for V2X communications (MN-V)

The main challenges of MN-V are covered by MA1 – link level performance in mobile channels, MA 2 – handover and cell reselection, and MA4 – enablers for mobile D2D (see Annex, Section 9.1.4 for more details). As a result, the concept is based on the use of D2D communication for the exchange of information between traffic participants (i.e. V2X communications) by means of unicast and broadcasting transmissions. In this sense, there is a close relationship with the HT D2D. Nevertheless, it is important to highlight that V2X communications pose additional challenges for D2D communication in terms of resource allocation. Network-controlled D2D communication schemes generally rely on the presence of perfect channel knowledge at the base stations, which might be only realistic in the case of static or slowly moving terminals. Moreover, the majority of D2D communication schemes consider D2D communication as opportunistic in order to improve the system capacity without providing QoS for the D2D links [PHK13]. Therefore, the concept is based on resource allocation and interference management schemes resistant to imperfect channel knowledge in the base stations (or even to the complete lack of channel knowledge) and focused in providing QoS for the D2D links according to the requirements of road safety and traffic efficiency applications.

In this sense the concept integrates the use of both network-controlled and pure ad-hoc D2D communication in a complementary manner. An important benefit of D2D communication in the context of road safety and traffic efficiency applications is the possibility to enable the exchange



of information between traffic participants even in locations with insufficient network deployment. While the coordination of transmissions performed by a central entity (i.e. a base station) allows for a better resource allocation and interference management compared to purely distributed coordination schemes, V2X communications should operate at some degree along the entire road network, and not only in the presence of network coverage. Nevertheless, it is expected that network-controlled D2D communication provides a significantly better performance than pure ad-hoc D2D communication as result of the superior resource allocation and interference management that can be achieved by means of a central entity.

Another important aspect is the introduction of the Framework for URC. This is based on the idea that a system designed to provide the required reliability at all times would result in an overdesigned system with a very inefficient air interface in terms of data rate and power consumption. Due to the sensitive nature of these applications, it is of paramount importance to warn the application about the unavailability of a reliable transmission link at a given location and duration as defined by the service-specific requirements, which calls for the incorporation of an availability indicator for reliability. Furthermore, the transmission link should be configured according to the service-specific requirements in order to maximize the availability of the ultra-reliable link. These two basic ideas constitute the foundation of the Framework for URC. In this regard, there is a clear connection to the HT URC.

In addition, the concept incorporates new advanced waveforms, channel coding, link adaptation and HARQ techniques, as well as advanced channel estimation and prediction techniques into the physical and MAC layers. The objective is to achieve a very high robustness against Doppler effects and better performance at link level by means of improved time diversity, while taking the stringent deadlines of road safety and traffic efficiency applications into account. At the same time, handover optimization mechanisms based on the exploitation of context information and interference identification are incorporated into the concept in order to improve the radio resource management, avoid handover failures and minimize the signalling overhead related to handover. Finally, a sufficient amount of spectrum needs to be allocated or available to V2X communications in order to satisfy the requirements of road safety and traffic safety applications.

Figure 3-8 illustrates a first version of the concept based on the high level solutions identified for MN-V cluster.

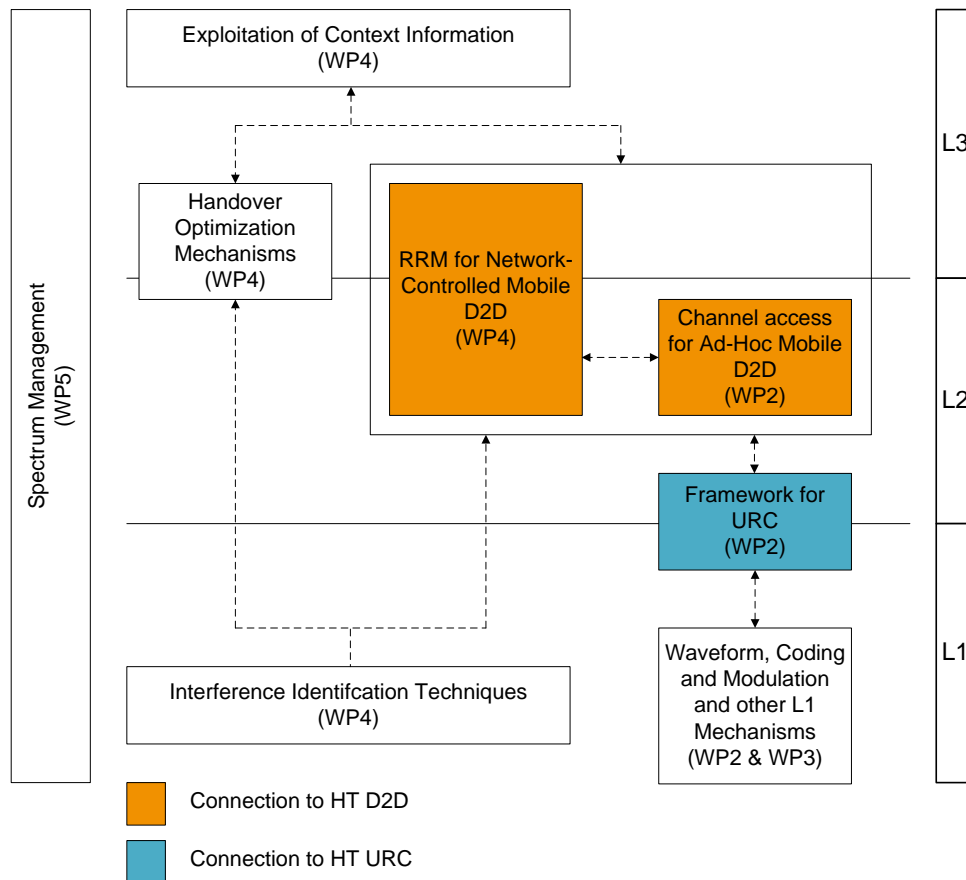

Figure 3-8: MN concept proposal – MN for V2X communications.

### 3.2.4 UDN

The following sections provide a specific concept for HT UDN. Please see the Annex Section 9.2 to get more details on the HT UDN TeCs selection.

#### 3.2.4.1 UDN concept proposal

The foundation for the UDN concept proposal is motivated by two main demands. The first demand relates directly to the METIS goals and the need for sufficient wireless capacity in densely populated indoor and outdoor environments for the expected increase of data volumes and user data rates in beyond 2020 scenarios. UDN is addressing this by increased network densification and studies on the enablers solving challenges and utilising benefits of UDN nodes in close proximity – this is labelled as the core part of the concept. The second demand is related to the coexistence of a UDN layer with other wide area layers or other RATs in the form of a heterogeneous multi-RAT/multi-layer deployment core and extended. Here, a special role is foreseen for macro networks/base layer services by novel approaches building upon a closer collaboration between macro and UDN nodes than in today's systems. Each of the extended proposal aspects can contribute to the core part of the concept separately.

For clarity, it is worth to mention that METIS is also investigating other solutions to enable a significantly increased network capacity per area which do not rely on UDNs. For instance, it is considered to evolve macro base stations towards improved CoMP and/or massive MIMO.



These solutions can be understood as alternative or complementary proposals to the METIS UDN concept through which the goals can be achieved. In this deliverable, HT UDN shows a main focus on novel and most promising aspects related with network densification challenges. Alternative components are presented in Annex Section 9.2.

The UDN concept proposal is depicted in Figure 3-9 where core and extended parts are shown. Connections to other HTs MN, D2D and MMC are also depicted. A more precise description of the concept is given in the two following sections with the short indication of the pillar technology components. The detailed list of TeCs is presented in Annex Section 9.2, including complementary and alternative TeCs contributing to the UDN concept.

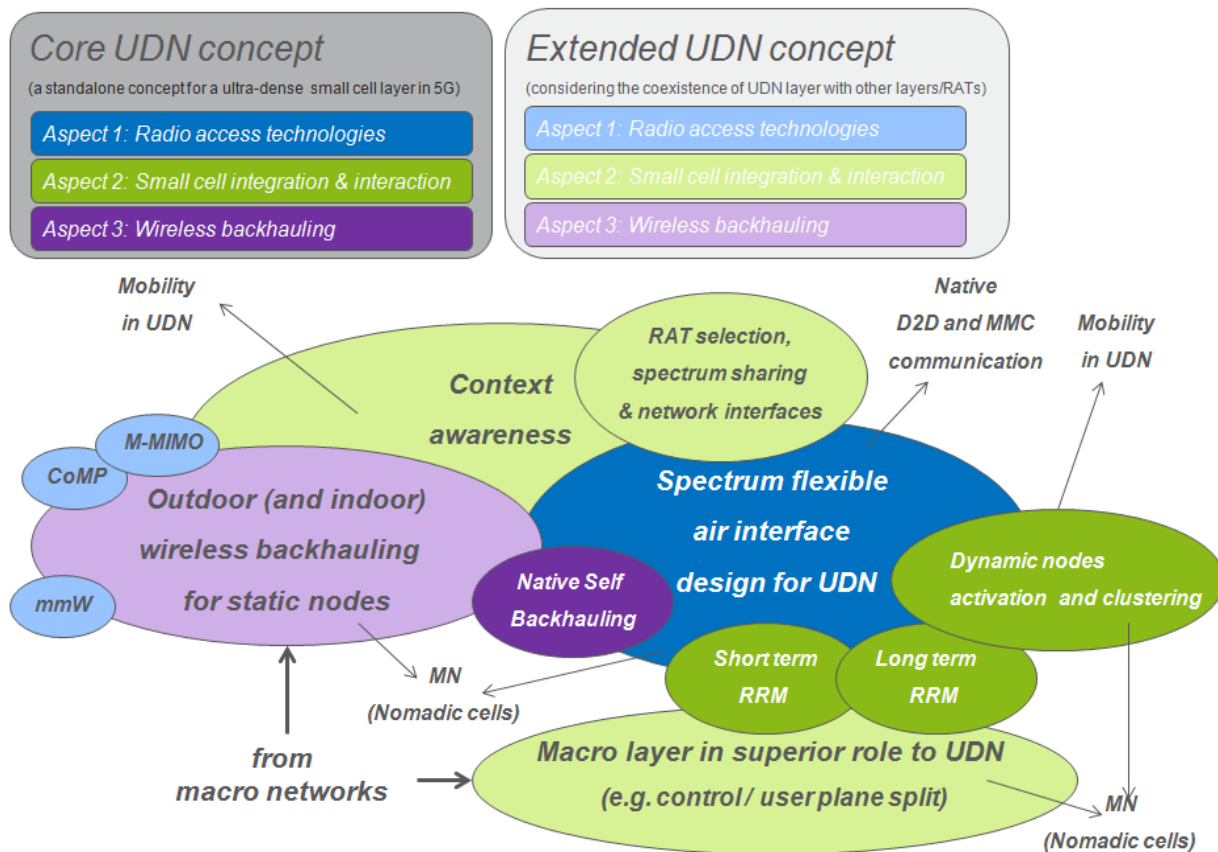

Figure 3-9: Concept proposal for UDN.

### 3.2.4.2 UDN concept – the core part

The proposed concept comes from an analysis of the requirements defined by METIS test cases [MET13-D11] and the analysis of the TeCs contributing to one of three key UDN aspects stated before. In result, HT UDN has a concept proposal for a new and potentially stand-alone system that will be optimised for indoor and outdoor hotspot areas. It is expected that the highest traffic increase will be observed in these two environments, and it will be related to e.g. video streaming, video calls, web browsing or interactive gaming. A straightforward way of addressing mentioned challenges is to decrease tremendously the distance between the user and the closest radio access node and by this ensure sufficient transmission conditions for reliable QoS and an increased reuse of spectrum over the area. The gains from close proximity of nodes are

significant. Short propagation times and delay spreads allow for a simplified design of the frame structure and in general overhead reduction. On short distances, communication via mmW can be applied, due to the more likely LOS transmissions and good interference isolation properties. The use of mmW has a great potential of very wide bandwidths that could easily give sufficient capacity, however there are also drawbacks in terms of the sensitivity of mmW beamforming towards the movement of the user and the potential interference between multiple beams.

At the current stage, the research on UDN Aspect #1 (radio access technology) in WP2 has progressed towards a new air interface design for UDN, where it seems possible to couple low (e.g. 3.5 GHz) and high frequency components into one holistic and harmonized solution. In this respect, TDD access schemes that are able to improve the utilisation of UL and DL resources seem to be preferred options, though for higher frequencies both FDD and TDD options are still being considered. A new flexible frame structure combined with additional MAC functionalities will create an efficient framework that will be able to deal with complex deployment and interference setups that will occur in practice (complimented with TeCs contributing to other UDN aspects). The KPI's improved by the proposed solution and key components contributing to the aspect "Spectrum flexible air interface design for the UDN" are listed below and depicted w.r.t. the OSI protocol stack in Figure 3-10.

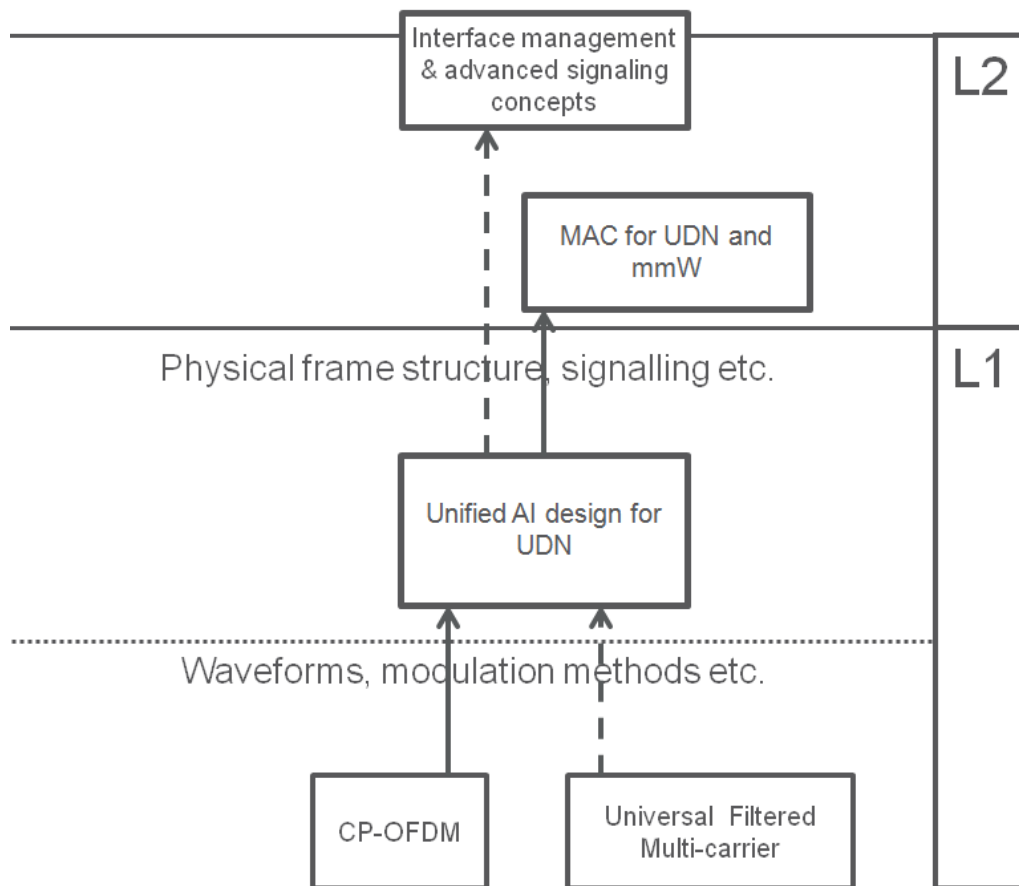

**Figure 3-10: The keystone TeCs for proposed UDN concept TeCs mapped on protocol layers 1 and 2 with an indication of ongoing (solid arrow) and potential (dashed arrow) collaboration.**



- Increased experienced user throughput by access to wider bandwidth and short link distance in ultra-dense deployments (WP2:TeCC#1, WP2:TeCC#4).
- Increased capacity for high traffic volume densities addressed by: flexible spectrum use including frequency bands from several GHz up to the mmW bands through a harmonized frame structure, high flexibility in use of UL/DL resources based on TDD access scheme for low and TDD optionally with FDD for high frequencies (WP2:TeCC#1) and new waveform based on the different OFDM proposals e.g. modified CP-OFDM (WP2:TeCC#1) or UFMC (WP2:TeCC#8.2) allowing relaxed symbol level synchronisation, higher spectral efficiency and better frequency separation for inband transmissions.
- Decreased latency by reduction of round trip time (RTT) to  $\approx 1$  ms and single TTI reduced to 0.25 ms or less for high frequencies (mmW) (WP2:TeCC#1).
- Reduced energy consumption: by support of fast (de-)activation of nodes and sleep mode by fast network synchronisation and control data RTT, transmissions in optimal conditions with reduced Tx power, energy efficient baseband processing (WP2:TeCC12.3 and WP4:TeC14).
- Reduction of network OPEX and CAPEX costs related to fixed backhaul by support of wireless self-backhauling (WP2:TeCC#1) and high data rates and capacity without major increases in receiver complexity (WP2:TeCC#8.2).
- Coupling cellular with D2D and MMC communication in unified air interface (see Sections 3.2.1 and 3.2.2).

A more detailed description of these TeCs can be found in [MET14-D23; MET13-D41].

The proposed solutions are also having drawbacks related with limited deployment applicability due to the maximal cell radius of up to 200 m and by only supporting of users with velocities up to 50 km/h or even less, in case of mmW. The limitations are related to design choices regarding frame structure and synchronisation approaches.

Related to UDN aspect #2 (small cell integration and interaction), the following components are considered in the core UDN concept:

- *Clustering algorithms and initial network setup.* For the purpose of self-integration, nodes should be able to create clusters, meaning that these discover themselves, exchange information and make initial resource allocation assumptions. In order to keep the maintenance cost low, the clustering procedure should support self-healing of the network (removing coverage holes created after not planned nodes deactivation). More details can be found in Annex Section 9.2.1.3 1).
- *Traffic dependent dynamic node (de-)activation.* Most likely, UDN nodes will be experiencing large traffic fluctuation over the day what makes some parts of the network not utilised efficiently. From this perspective, network layer and radio resource allocation functions need to be enhanced in a way to respond to major fluctuations in local capacity demands. It will require very dynamic and quick reactions related with node collaboration on multiple levels including node (de-)activation for reasons of energy efficiency. More details can be found in Annex Section 9.2.1.3 1).
- *Short and long term radio resource and interference management.* In a further step, nodes selected to be superior to others or distributed algorithmic procedures should



monitor instantaneous traffic demands and interference levels from own but also other networks and adjust resource allocation considerations accordingly. This process can vary in time scale from a few to some hundreds of TTIs depending on the concrete solution proposals. Both the short and the long term RRM algorithms should use a URC-L service reliability criteria (defined in Section 3.2.5) to make a fair estimate of the own network capacity and react accurately. More details can be found in Annex Section 9.2.1.3 2-4).

- *User mobility in ultra-dense deployments:* can be a real challenge related with handover procedures due to the short ISD between neighbour nodes or usually very fast changes of propagation channel conditions related with indoor obstacles. In existing systems, mobility relies on HO procedures and neighbourhood measurements, while in METIS novel approaches are investigated. Some further information can be found in Annex Section 9.2.1.3 5), but the most novel solutions supporting UDN are reflected in extended proposal for UDN concept.

The aspect #3 (wireless backhauling) in the core UDN concept can be detailed as:

- *Wireless self-backhauling & network coding schemes.* For indoor and outdoor deployments there is an additional difficulty related to the lack of sufficient backhaul infrastructure in locations that they require increased capacity due to the higher traffic demand. Also from economical or legal reasons dens copper/fiber deployment might not be accepted to fulfil URC-L requirements. To avoid this problem, the METIS concept proposes to use relaying schemes for self-backhauling of access nodes (including network coding techniques presented in [MET14-D32]) and proposed solutions should focus on the reduction of relaying overhead and associated latency.

To summarize this section, the core part of the concept proposes a new stand-alone system optimised for ultra-dense deployments that is using novel approaches for air interface, radio resource, spectrum, and network management techniques to achieve METIS goals by increased network density, new spectrum opportunities and higher efficiency of multiple mechanisms in comparison to today's systems.

### **3.2.4.3 UDN concept – the extended proposal**

The extended part of the UDN concept is focused on novel functionalities e.g. related to coexistence of a UDN layer with other network layers, networks of different operators or looking at the new functionalities related with processing of the user behaviour information. Proposed sub concepts come from TeCs analysis and at this stage of the project it is not clear if they importance will be further increased or reduced in HT specific concept proposal. Extended part of the concept still requires further feasibility and applicability analysis in following months.

The base network layer (macro layer) can play a superior role to a UDN layer e.g. by advanced network management related to node (de-)activation or by decoupling of C-Plane and U-plane between macro and small cell layer, e.g. utilize the macro layer for critical control information on QoS relevant procedures, while performing traffic offload to the nearest UDN node. These aspects aim to the same requirements as the MN-N cluster related to nomadic cell network management.

The deployment planning for UDN and correspondingly support of each site with sufficient backhaul links may not be feasible in all cases. For economic reasons, deployment and renting of fixed backhaul links might not be feasible, especially if the utilisation of the backhaul capacity



will be low on average over the day. UDN outdoor deployments but also in some cases in indoor environment can be supported by macro infrastructure with high spectral efficiency for wireless backhaul link for static nodes. In this case macro base stations beside basic functions related with direct user access additionally might support UDN nodes with backhaul links. In comparison to classical relaying there are no restrictions expected with respect to inband or outband transmission or even to the involvement of different RATs. The potential solutions can be based on “classical” (i.e. lower) or mmW frequency bands involving evolutionary but also revolutionary solutions in comparison to LTE-A with enablers like massive-MIMO, CoMP or interference alignment. These are interesting enablers as auto integration functionalities allow deployment of the nodes based on the local and periodic traffic extremes and in the same time avoiding expensive payments for fixed backhaul links for every single UDN node. In this context the backhaul link will adapt to local traffic demands. This solution proposal aims to the same requirements as the MN-N cluster which requires wireless backhaul for nomadic cell.

Additional functionalities should be enabled for UDN to react on the capacity shortages that could not be solved by RRM mechanisms. One of the solutions should be communication with external entities responsible for inter-operator spectrum management, e.g. by sharing of licensed and/or unlicensed bands. Another way is to make a decision on the RAT selection based on the available knowledge. For both, the spectrum or RAT selection might be integrated from the optimal network level performance point of view. Another need for sharing spectrum between MNO's on low frequencies is to offload MMC services to UDN for low cost and low power devices with very limited support of frequency bands and limited processing capabilities.

For the purpose of handling the problem of user mobility in dense deployments, the network might be able to utilise context information from user behaviours in concrete locations in the past combined with instantaneous e.g. application specific information or exact user location in order to be aware of short term possible user demands and predict handover decisions to meet URC-L requirements including the handover areas between UDN and macro deployments. Another use case for context awareness is possible traffic fluctuations and related with nodes (de-) activation.

For the above mentioned new network functionalities it will be required to establish also new network interfaces providing sufficient information exchange between MNOs on protocol level; additionally these interfaces should allow flexible integration with other MNO network management systems.

As a summary, the considered aspects included in the extended version of the UDN concept proposal are listed below and further described in the Annex Section 9.2:

- Use of context information for mobility, service reliability and network management (Annex Section 9.2.2).
- Inter-operator spectrum sharing management and optimal RAT selection (Annex Section 9.2.3).
- New inter-network interfaces (Annex Section 9.2.3).
- Efficient wireless backhaul links for UDN served from macro networks (Annex Section 9.2.4).
- Superior role of macro nodes in UDN management, potentially including split of control and user planes between macro and ultra-dense radio node considerations (Annex Section 9.2.5).



### 3.2.5 URC

HT URC introduces novel features and performance parameters in future wireless systems, not considered in the current mainstream systems and their short-term extensions. For example, providing URC long-term (URC-L) and “almost constant connectivity” will give rise to cloud-based services designed to take advantage of the higher reliability of the connection in terms of optimization of the storage, computational burden, etc. Providing URC in short-term (URC-S) can be instrumental in enabling futuristic scenarios with smart traffic intersections and reliable inter-vehicle communication, as well as guaranteed connectivity for the sensors/actuators of the critical infrastructure. Having URC emergency (URC-E) as an operating mode of the system will bring much more widespread and reliable connectivity upon e.g. natural disaster and damage to the infrastructure.

Due to the difference between the three URC clusters (URC-L, URC-S, URC-E), there is a difference in the sets of TeCs suited for a particular type of URC problem. While the cluster URC-E is quite specific, with the damaged infrastructure being the main reliability aspect, for URC-L and URC-S there is a generic set of relevant TeCs that address the problems of multiple reliability aspects. More specifically, such a generic toolbox for achieving very high reliability consists of the following:

- *Spectrum allocation and management.* These tools are considered within WP5 and refer to the capability to flexibly reallocate spectrum in order to achieve:
  - Offloading to another frequency band, when the number of users increase and reliability is threatened due to the RLA3 (Resource depletion due to competing devices).
  - Operate in a less-interfered spectrum chunk, when there is a significant interference and reliability is threatened due to RLA2 (Increased uncontrollable interference).
  - Operate in a dedicated spectrum chunk to attain a specific KPI: for example, low-latency D2D operation or operation at a lower frequency in order to achieve a larger range.
- *Robust PHY mechanisms.* For a given spectrum allocation, improve the PHY reliability through one or more of the following available tools:
  - Robust waveforms, such as WP2 TeCC#8.1 (FBMC) and WP2 TeCC#8.2 (UFMC), robustness towards imperfect channel estimation or non-coherent operation (WP3 T3.2 TeC16).
  - Interference mitigation/cancelation. An associated enabling TeC in WP4 is T4.1-TeC1-A3: Interference Identification using multi-layer inputs.
  - Large-scale spatial diversity of Massive MIMO (WP3 T3.1), for example by stabilizing a link by through a sheer energy collection.
  - Additional infrastructure nodes and/or inter-node cooperation, such as CoMP (WP3 T3.2) or relays (WP3 T3.3)
- *Signalling structure and interface management.* This is addressed by WP2 TeC#4. The signalling structure must be able to dynamically adapt, on one hand, to low-latency requirements (URC-S) and, on the other hand, offering minimal rate within desired radio coverage (URC-L). The signalling structure should also be able to support flexible spectrum allocation.

- *Multi-RAT* can be essential for improving the reliability and availability, introducing diversity on top of layer 2. While simple switching among RATs has been already established, an improved integration and cooperation among multiple RATs can bring significant improvements, especially in URC-E. A representative TeC is T4.2-TeC5-A2 (User anchored multi-RAT self-managed load) in WP4.
- *Reliable service composition*. This can be seen as information propagated from the lower layers to the higher layers, such that the latter decrease their demand. For example, if the lower layer signals inability to support the normal operation, the higher layer goes to a mode in which only critical data is transmitted. This is well exemplified by the framework for URC, adopted in TeC6 of WP2 (Air Interface for Moving Network).

More information on the TeCs can be found in [MET14-D23; MET13-D31; MET13-D41].

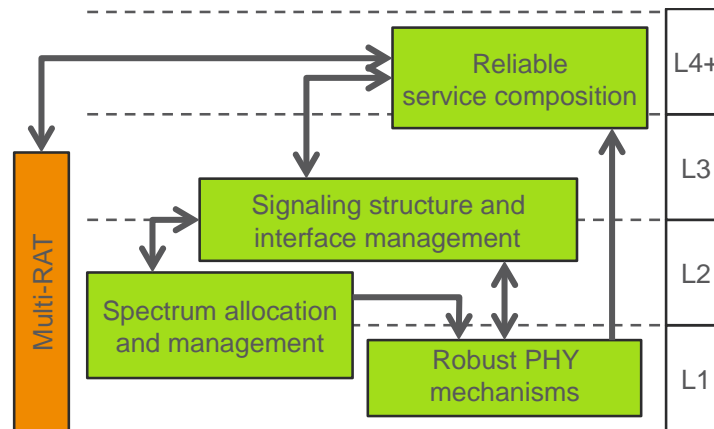

**Figure 3-11: Toolbox of generic mechanisms for URC and their interactions.**

Figure 3-11 depicts the relationship among the four generic mechanisms for achieving ultra-reliable communication, applicable both to URC-L and URC-S. Spectrum allocation and management has unidirectional connection towards the Robust PHY mechanisms since the allocated spectrum lays down the constraints under which a certain PHY technique should operate. The bidirectional connection between the Signalling structure and Spectrum allocation reflects the fact that the overall signalling structure should be able to manage a set of heterogeneous spectrum chunks, while on the other hand, the signalling structure transmitted in a specific band needs to be adapted to the constraints or the specific mode (e. g. D2D) for which that band is used. Note that there is a unidirectional connection between the Robust PHY techniques and Reliable service composition, which denotes the fact that the service requirements should be rapidly adapted to what is offered by the physical layer – e. g. decision on restricting the communication only to the most critical set of messages. Finally, multi-RAT is listed as a component that parallels the other blocks at layers 1, 2, and 3. Note that although the other RATs may not contain any of the advanced METIS TeCs, the fact that those RATs are available in a device implies that their integration with the METIS radio access creates a new URC enabler.

### Cluster: Long-term URC (URC-L)

The general problem in URC-L is how to guarantee certain rates to multiple users over longer periods, with high probability, by utilizing available resources and the different technology blocks from Figure 3-11. Specifically, URC-L targets moderate-to-high data rates, as considered in TC2, TC6 and TC7, for providing an ordinary, rather than emergency connectivity. The relevant reliability aspects (RLAs) are 1 to 4.

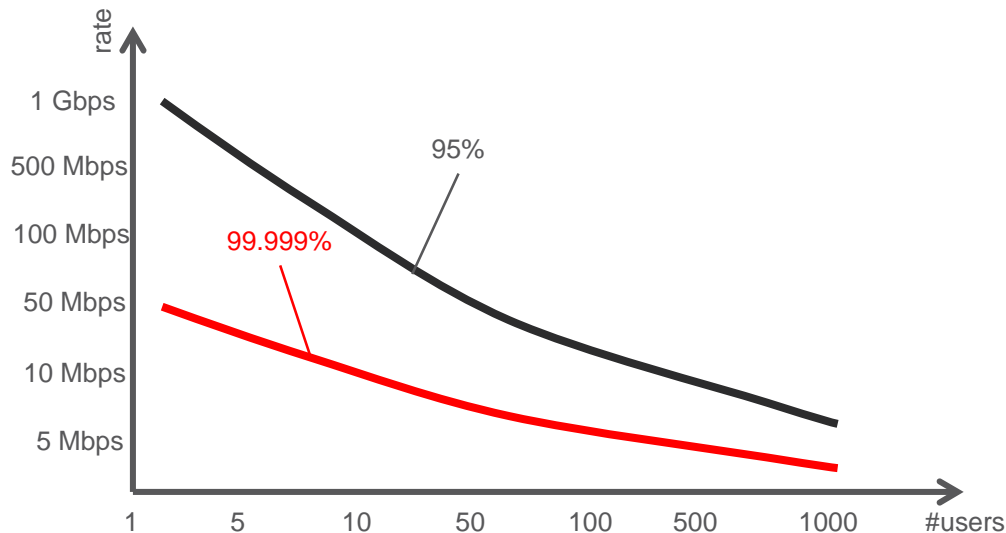

Figure 3-12: Illustrative graph for URC-L where the average rate is depicted as a function of the number of users.

Figure 3-12 depicts a diagram of the rates that can be guaranteed for a certain percentage of time vs. the number of users. The numbers are only illustrative, not exact and the motivation is to show how a desired URC-L performance could look like. For example, the curve marked with 95% shows the average rate that can be guaranteed to each user with probability 95%. This graph shows explicitly how the system architecture and the associated TeCs are addressing RLA3 and the competition among users for resources, but it is implicit that the other RLAs are addressed.

The probability to achieve certain rate is defined over a period much longer than 10 ms, as well as a given coverage area within which the users are situated. This should be done in a consistent way for a given test case or when a given TeC is evaluated, such that we do not account for the users that are outside the nominal coverage area of the considered infrastructure. It should be noted that in dense deployments, in which a user can be connected to more than one access point at the same time, the coverage area is more involved, beyond a simple geometric specification. A way to define the coverage would be the area in which a user is able to receive control information from the infrastructure during 99.999% of the time.

The key to achieve high performance in terms of URC-L is not the ability to support a high peak rate, but the ability to use the resources and degrees of freedoms in a way that scales with the number of users. The key enablers of the guaranteed rates as the number of users scales are:

1. **Massive MIMO**, where the spatial degrees of freedom can be utilized for scaling towards a large number of densely distributed users. Representative TeCs in WP3, T3.1, are TeC1 and TeC11.





2. **CoMP**, where multiple access points in the infrastructure can run a distributed algorithm in order to scale with the number of users, instead of improving the peak rate in the area. Representative TeC in T3.2 is TeC10. A related TeC in WP4 can be considered to be T4.1-TeC7-A5 (Self-organization of neighbouring femtocell clusters – cell edge performance).
3. **Flexible spectrum allocation and signalling structure**. This implies that the system is able to invest additional spectrum when the number of users requires that. This can be achieved by having a proper frame/signalling structure that supports such flexibility. Representative TeC in WP4 is T4.1-TeC6-A2 (Out-of-band advanced block scheduling in heterogeneous networks), in WP5 is Inter-UDN Co-ordinated Spectrum Sharing. They should be supplemented with TeC4 (Interface management and advanced signalling concepts) in WP2.
4. **Radio node densification**. The concept and the TeCs of the HT UDN do contribute to the improved reliability and, from the viewpoint of URC-L, they need to be considered in the context exemplified on Figure 3-12.

More information on the TeCs can be found in [MET14-D23; MET13-D31; MET13-D41].

The two main research challenges for URC-L are:

- The relevant TeCs can be designed in a different context as objectives, as specified by the URC-L requirements and target performance, as exemplified on Figure 3-12. In that way it will be possible to evaluate the potential for supporting URC-L in the TCs with densely populated users, such as TC2, TC6, and TC7.
- Synergy among the key enablers listed above, evaluation how much can be achieved by Massive MIMO and CoMP in a given spectrum and interplay with the flexible spectrum allocation.

### **Cluster Short-term URC (URC-S)**

Figure 3-13 illustrates the target performance in terms of latency as a function of the number of users. Similar to URC-L, the graph shows explicitly how the performance depends on the competition among users for resources, but it is implicit that the other RLAs are also addressed. For example, note that on Figure 3-13 latency less than 2 ms with 99.999% guarantee cannot be achieved even for a small number of users e.g. due to a limitation imposed by the propagating conditions. Note that URC-S refers to more heterogeneous test cases as compared to URC-L, ranging from smart grid in TC5, MMC in TC11 to vehicular communication in TC12. Therefore, the graph on Figure 3-13 should be suitably adjusted to the test case in question – for example, in TC11 the number of competing devices can be into the range of thousands, while in TC12 it will be in the order of tens.

The key enablers of URC-S, regardless of the test case in question, are:

- A flexible signalling architecture that can rapidly allocate resources (WP2)
- Techniques that explicitly consider deadlines, such as for example deadline-driven HARQ (WP2).

- Reliable service composition and prioritization of latency-critical messages down to the physical layer. This prioritization should be reflected in the contention protocols, resource allocation, transmission power adaptation, etc.

Specific to the TCs, the enabling technologies are:

- TC12: The relevant TeCs are part of the MN-V cluster and include: Air interface for MN (WP2), Framework for URC (WP2), and RRM for Network-controlled Mobile D2D (WP4).
- TC11 and TC5: Protocols for massive access, signalling for MMC (WP2)

Another TC for which URC-S is relevant is TC2, with respect to the public cloud and requires very low latency.

More information on the TeCs can be found in [MET14-D23; MET13-D41].

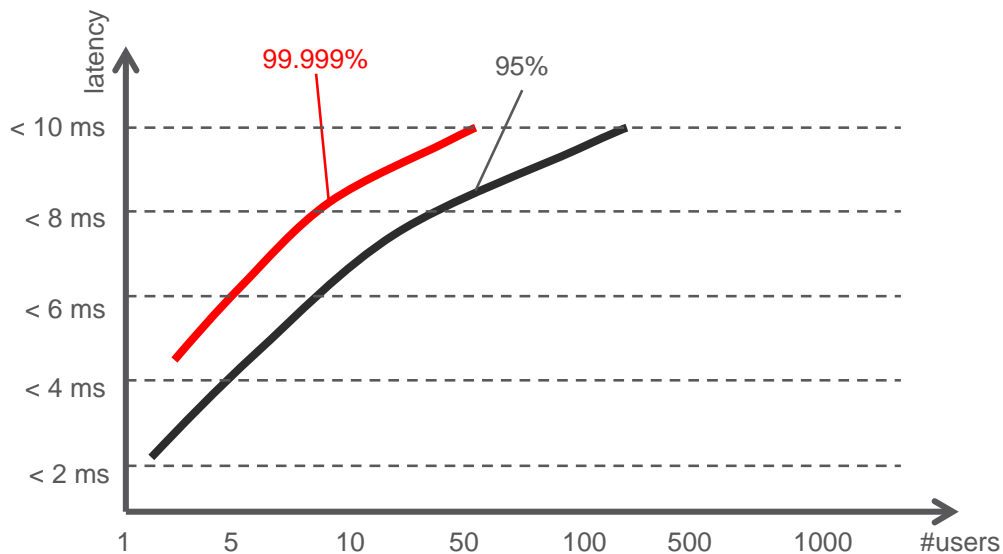

**Figure 3-13: Illustrative graph for URC-S where the latency is depicted as a function of the number of users.**

The main research challenges for URC-S are:

- Optimization of the end-to-end latency that occurs when combining multiple TeCs at different layers and the associated prioritization of the low-latency messages across all the layers.
- Problem formulation that targets the KPI as depicted on Figure 3-13.

#### **Cluster: URC for emergency (URC-E)**

This problem is mainly related to the RLA5 (Equipment failure) and TC10 (Emergency communications) when the infrastructure becomes partially damaged or dysfunctional due to, for example, a natural disaster such as an earthquake. Differently from URC-L and URC-S, where we have emphasized the performance with respect to the increasing number of competing users, here the most important parameters are:



- The time it takes to establish a connection at a certain data rate  $R$  as a function of the percentage of the damaged infrastructure in the area.
- The probability that a device will be able to send a message of a given size within a certain time-frame.

The enabling TeCs for URC-E are:

- WP4 D2D concept, including network assisted discovery and network assisted communications.
- Multi-hop and relaying techniques in WP3, such as cooperative D2D communications.
- Technologies in the MN-N cluster (MN for nomadic network nodes), as the nomadic nodes can be used to establish an ad-hoc wireless infrastructure. However, as noted in the description of the MN-N cluster, use of nomadic nodes in the context of URC-E requires a redefined functionality compared to the use of nomadic nodes in integration with the infrastructure.
- Improved RAT integration and cooperation among multiple RATs, introducing diversity on top of layer 2, improves the reliability and availability.

More information on the TeCs can be found in [MET13-D31; MET13-D41].

### ***Summary of the URC concept***

The described elements of the URC concept clearly outline the innovation potential introduced by this HT. The URC concept serves as a guideline for to channelize various TeCs into supporting certain reliability-related feature. It should be reemphasized that the goal of URC operation cannot be attained by only changing a parameter in the current system design, but it should be accounted for already in the design and the optimization. For example, achieving URC-L performance as indicated on Figure 3-12 is not only a matter of changing a parameter in a scheduling algorithm, but it affects the deployment of the infrastructure and specific control signalling. To the best of our knowledge, the reliability aspects and the segmentation of the URC-related problems into three clusters (URC-L, URC-S and URC-E) is the first systematic approach towards enabling URC in future wireless systems.

### **3.3 Meeting the METIS goals**

Each HT addresses a sub-set of the METIS technical goals and contributes to the overall system. The mapping between goals and HTs is shown in Table 3-1 that gives the most important characteristics of how each HT addresses the goals. We here briefly discuss the primary methods that can contribute most beneficially to achieve the goals and which HTs primarily address the goals according to our first views on the METIS concept. We also indicate some of the most promising TeCs currently developed by the METIS WPs and integrated in the HT concepts as described in Section 3.2.



**Table 3-1: HTs and METIS goals.**

Horizontal Topics		D2D	MMC	MN	UDN	URC
<b>METIS overall technical goals</b>	1000 times higher mobile data volume per area	Traffic offloading		Densification with nomadic nodes; high throughput mobile links	Densification; improved efficiency and new spectrum opportunities	
	10 to 100 times higher typical user data rate	Traffic offloading		Densification with nomadic nodes; high throughput mobile links	Densification; improved efficiency and new spectrum opportunities	
	10 to 100 times higher number of connected devices		Low signalling overhead, user multiplexing improvements			Graceful degradation of rate and increase of latency as the number of users scale
	10 times longer battery life for low power devices		Low signalling overhead, sleep mode			Beneficial in disaster applications when using low power devices
	5 times reduced E2E latency	Local traffic		Local traffic in mobile environments; low-latency mobile links	Indirectly by providing sufficient capacity for higher traffic volume and data rates	In real-time applications

### 3.3.1 1000 times higher mobile data volume per area

The primary methods to address this goal are to use more frequency spectrum, to use more network nodes and to enhance network performance and spectral efficiency. The HTs addressing this goal are D2D through traffic offloading from cellular to D2D links; MN through network densification with nomadic nodes and high throughput mobile links; and UDN through network densification, improved efficiency and new spectrum opportunities.

- Use more frequency spectrum:

Both higher data rates and higher data volume require access to more frequency spectrum for mobile communications. At the World Radiocommunication Conference 2015 (WRC15), it is expected that clearly more spectrum will be released for mobile communications. This new spectrum lies in the frequency range between 300 MHz and 6 GHz. However, for the future



METIS system these new spectrum opportunities will not be sufficient [MET13-D51]. Additionally the release of new spectrum in the mmW bands was postponed to WRC18.

Moreover new spectrum access schemes are being considered such as Licensed Shared Access (LSA) [MET13-D51] that would allow using further spectrum for mobile communications especially in higher frequency bands in a more flexible way. Accordingly METIS is currently developing novel spectrum access schemes as well as e.g. methods for coordinated spectrum sharing between different UDNs, supporting network densification as addressed below.

Also wireless local area network (WLAN)-type systems [IEEE12-80211] operating in the unlicensed bands, such as the ISM and U-NII bands at 2.4 and 5 GHz, as well as the 60 GHz band, may be more tightly integrated.

- Use more network nodes:

Densification of networks by deploying more nodes is already applied today with femto or pico cells providing local connectivity for increased capacity in addition to the macro cells in the wide-area. This trend is expected to continue, where the small cells may make use of higher frequency bands, such as the 3.5 GHz bands or the mmW bands. The use of TDD with small cells may become more prominent as compared with 3G/LTE today. The different network layers/cell hierarchies and radio access technologies (RATs) are to be integrated by means of smarter networks. Dedicated implementation solutions such as distributed radio heads may be developed for specific deployments such as for providing coverage of very crowded places, e.g. stadiums, events etc. For this METIS is developing a large number of TeCs supporting MN and UDN, e.g. solutions for in-band backhaul, where the access and backhaul share the same spectrum [MET14-D32], specific distributed RRM schemes, or Dynamic Nomadic Node Selection for Backhaul Optimization [MET13-D41].

- Enhance network performance and spectral efficiency:

Enhanced network performance and spectral efficiency are to be achieved by applying more sophisticated protocol and air interface technologies as compared to LTE-A. The primary air interface technologies in this regard are the use of multiple antennas, possibly involving massive antenna constellations [MET14-D32], multi-stream transmission such as spatial multiplexing [MET14-D32] or non-orthogonal multiple access [MET14-D23], and cooperation techniques such as coordinated multi-node transmission [MET14-D32] or solutions based on interference alignment [MET14-D32].

### 3.3.2 10 to 100 times higher typical user data rate

The primary methods to address this goal are to use spectrum aggregation, more dynamic spectrum access, usage of higher frequencies up to mmW frequencies (30 to 300 GHz) and short-range communications. The HTs addressing this goal are D2D and MN by providing short-range communication; and UDN through utilizing higher frequencies. More dynamic spectrum access can be utilized by all HTs.

- Spectrum aggregation:

Spectrum aggregation is already defined by 3GPP LTE-A and enables peak data rates up to about 1 Gbps. This may evolve further to take into account the new bands released during WRC15. Aggregation of multiple bands over a wide range of frequencies poses challenges concerning the cost and efficiency of radio frequency filter and transceiver solutions, in particular for the user terminals.

- More dynamic spectrum access:

METIS is developing TeCs for Spectrum opportunity detection and Assessment, and Spectrum management concept for LSA. Based on the need for spectrum, these TeCs will



help to obtain spectrum by negotiating access to it with other entities and also assessing the use of spectrum.

- Usage of higher frequencies:

Usage of higher frequencies up to mmW frequencies will further increase the achievable data rates to, say, 10 Gbps or beyond. To compensate for the path loss at such frequencies, high antenna directivity is required if transmission range shall be beyond a few meters. Flexible air interfaces for mmW frequencies are developed in METIS [MET14-D23]. The identification of suitable frequency bands [MET13-D51] and the characterization of the propagation channel are currently under investigation in the project [MET14-D12].

- Short range communications:

Finally, reducing the transmission distance, approaching short-range communications, e.g. D2D or UDN [MET13-D41] is also an efficient means to increase user data rate. Indeed, node densification and Dynamic RAN (cf. RAN 2.0 described in Section 3.1.1) would allow confining interference to very specific areas of use while reducing the signal attenuation. Both effects shall boost the Signal to Interference plus Noise Ratio (SINR) thus increasing the user data rate by a logarithmic law.

### 3.3.3 10 to 100 times higher number of connected devices

The primary methods to address this goal are to reduce signalling overhead, to use dynamic profiles of users, and to implement traffic concentration, in particular for MMC applications. The HTs addressing this goal are MMC through low signalling overhead solutions and user multiplexing improvements; and URC through the reliable service decomposition providing mechanisms for graceful degradation of rate and increase of latency, instead of dropped connections, as the number of users scale.

- Reduce signalling overhead:

Signalling overhead can be reduced by designing more efficient protocols and by thinning out some protocol layers e.g. for the simplification of E2E procedures. On the air interface the signalling for random access, time adjustment and/or resource assignment can be reduced, for example, by using contention-based access, waveforms that are more tolerant to timing mismatch as compared to OFDM, and/or by resource reservation, making the air interface more flexible and suitable for small payload traffic. For instance methods dedicated to Contention based access for massive number of devices without scheduled access and Multi-user detection facilitated by Compressive Sensing are being developed in METIS [MET14-D23].

- Use dynamic profiles of users:

NFV technologies may play a role to overcome current limitations of a rigid protocol stack by allowing flexible configuration of the network functionalities. The future air interface shall support this flexibility by using dynamic profiles of users, which entries are configurable to pre-defined use cases. In this sense, some radio functions will be activated/deactivated on demand depending on the specific needs of the service and the status of the network, see e.g. [MET13-D41] for TeCs addressing activation/deactivation of network nodes. Again, the user-centric paradigm applies here, since the network shall adapt its own topology and operation mode according to the needs of each user.

- Traffic concentration:

Finally, traffic concentration can be achieved by means of gateways, for example, by linking a capillary MMC network to a wide area cellular network. In this framework, the RAN might configure one specific device to act as such concentrator by using D2D communications to collect all data from the surrounding machines. It is expected that this last hop link should work on a different radio interface to host a large number of mesh devices with severe



energy constraints. For instance here METIS develops techniques to reduce the amount of traffic in gateway-based MMC solutions by context-based device grouping and signalling [MET13-D41].

### **3.3.4 10 times longer battery life for low power MMC devices**

The primary methods to address this goal are to improve air interface, procedures and signalling, and to reduce the distance between the MMC device and the access node. The HTs addressing this goal are MMC through low signalling overhead and sleep modes; and URC in disaster applications when low power consumption in devices is used.

Techniques to improve the air interface include the use of sleep modes, energy-efficient modulation, coding and multiple access schemes, for example, use of constrained modulation techniques such as GMSK, very robust coding and/or spreading allowing very low transmission powers, and simplified procedures such as those introduced for the previous goal.

The MMC device can, in some scenarios, be brought closer to the access node, for example, by gateways connecting a capillary network to a wide area network, or by denser deployment of small cells.

### **3.3.5 5 times reduced End-to-End (E2E) latency**

The primary methods to address this goal are to use more efficient network architectures, more efficient air interface designs, signalling and procedures, better QoS differentiation, and direct D2D communication. The HTs addressing this goal are D2D and MN by localizing the traffic and providing low-latency mobile links; UDN indirectly by providing sufficient capacity for higher traffic volume and data rates; and URC in real-time applications (URC-S). The system architecture also plays an important role in meeting the reduced latency goal.

- **Efficient network architectures:**

Low latency network architectures are concerned with shortening the distances and number of hops between the user and the content, for example, by distributing some network functions that are centralized today or by applying local and universal caching as well as local breakouts to external networks like Internet, service provider or enterprise networks.

- **Efficient air interface designs:**

The air interface may adapt the frame structures in order to reduce TTI and/or HARQ round trip times as shown in [MET14-D23]. While this can efficiently be implemented at the higher frequencies where more bandwidth is available, this can become very inefficient for wide area coverage. Signalling and procedures may be thinned out, by simplifying their components.

- **Better QoS differentiation:**

Better QoS differentiation is important in this context. As the low-latency transmission may become inefficient, it should only be applied with the services that require such low latencies and should be avoided with delay-insensitive services.

- **D2D:**

D2D can be used between devices within transmission range of each other which saves a radio hop and the routing of traffic through the network. In some case it may be applied also for local broadcasting, for example in MN-V where vehicles broadcast position/velocity information to enhance traffic safety.



## Cost and energy efficiency

The key challenge is to achieve the above goals at a similar cost and energy consumption as today's networks [MET13-D11]. In order to not increase the energy consumption, as the traffic volume increases, the energy efficiency must improve compared to today's networks.

This challenge is addressed in particular by smarter networks making use of SON, SDN and NFV techniques as integral parts as described in Section 3.1.1.

Improvements in energy efficiency can be provided by novel air interface designs, including signalling procedures, with low energy requirements in low load cases that enable to switch off some functionality of the access nodes [EAR12-D33; OCF+13]. Moreover, if the signalling is properly designed, network densification and maximum capillarity as provided by HTs D2D, MN and UDN will also reduce the power requirements by reducing the necessary transmit power. MMC solutions are inherently energy efficient to maximize the battery lifetime. Energy performance improvements can be achieved e.g. by separating the control and data planes, to minimize the "always on" signalling, and support discontinuous transmission and reception in the data plane. Accordingly METIS is developing TeCs for the activation and deactivation of network nodes as indicated previously and for the separation of control and data layers, applicable to HTs MN and UDN [MET13-D41]. METIS is the "carrier project" for the 5GrEEen project within the framework of EIT ICT Labs. 5GrEEen is working on energy efficiency improvements and standardization topics [5GrEEen14] and METIS will benefit from the energy efficiency-solutions developed in 5GrEEen.

The network OPEX, which is the part of the OPEX that can be addressed by METIS, accounts for approximately ¼ of the total OPEX [Wal12; BB09]. Areas for network OPEX reduction include energy consumption, network virtualization, and backhaul.

The energy consumption, relevant for energy efficiency, is a significant part of the network OPEX, and hence the OPEX is reduced by improving the energy efficiency.

Network virtualization allows telecom operators to adopt more cost-effective and flexible solutions that can be scaled to keep up with service demands [DK13]. Virtualization also allow operators to quickly and easily implement and deploy new services, reducing the time and cost to introduce new services to the market. Different services can be located in different logical network slices while using the same physical resources.

Increasing traffic volumes increases the demand for and cost of backhaul solutions [BB09]. METIS is investigating back-haul and transport solutions for 5G networks, e.g. self-backhaul in UDNs, as well as techniques to integration of small cells, which both address this aspect of OPEX.

CAPEX is affected by number of infrastructure elements and cost of the infrastructure elements. In UDN deployments, D2D communication and support of wireless self-backhauling contribute to reducing CAPEX. Improvements in e.g. massive MIMO will make the capacity provided by macro nodes increase faster than the cost, further reducing CAPEX. CAPEX is also affected by energy efficiency, since reduced power dissipation allows more cost-efficient solutions in, for example, battery backup and cooling systems [FFJ+14].

## 3.4 Continued METIS 5G system concept development

Figure 3-14 shows the mapping between the METIS goals, the HTs, and their different aspects. The figure also indicates the next steps towards the integrated METIS system concept. This is developed through the integration of the HT-specific concepts plus complementary technologies,



e.g. massive MIMO. The evolution of existing standards will also be considered. In the integration of the HT-specific concepts we will exploit the fact that some of the HTs have significant commonalities. However it will be necessary to do trade-offs between the optimal performance of each of the HT-specific concepts and the effort needed for achieving the overall integration. The final METIS system concept will comprise a description of the selected TeCs and their interactions (system architecture) as developed to reach the METIS goals.

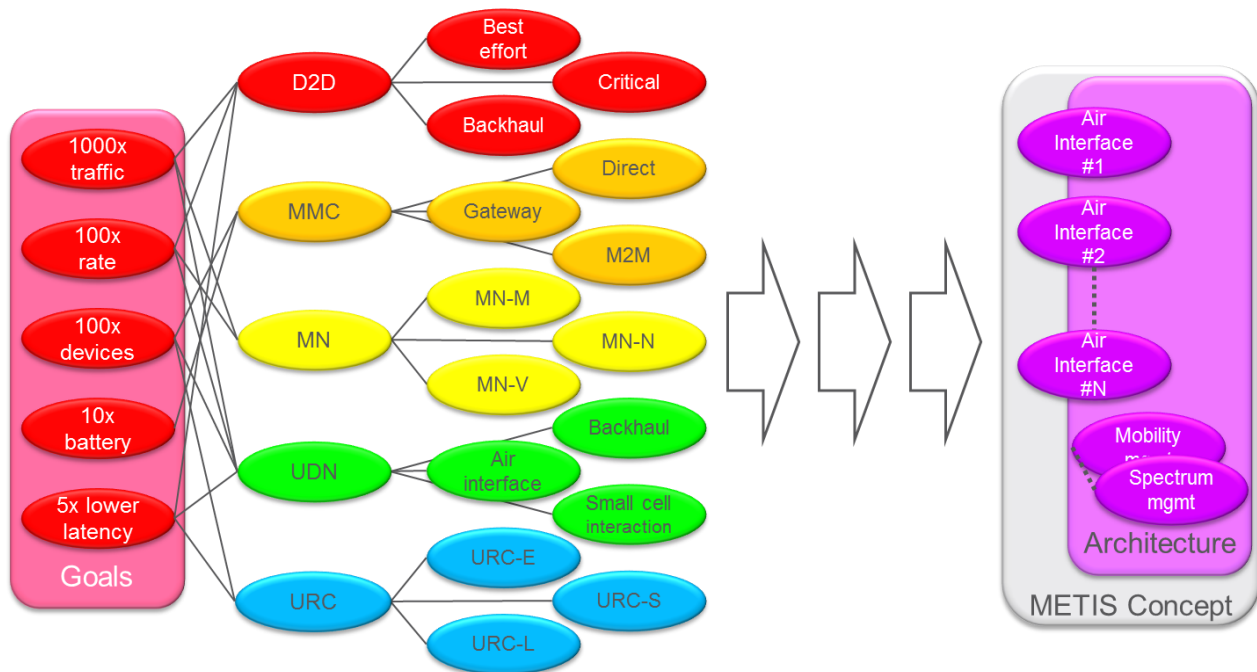

**Figure 3-14: Mapping of the METIS Goals to the METIS concept via HTs.**

The first step in the integration process is to identify and refine interactions and synergies between the HTs. As already indicated in the sections describing the specific HT concepts, there are several aspects and test cases which are relevant to multiple HTs. We here give four examples of the interactions and synergies.

A first example of interaction is for TC12 Traffic Efficiency and Safety. It is addressed by the MN-V cluster, while in terms of performance requirements it belongs to the URC-S cluster. High reliability in V2V communication is achieved through network-controlled D2D, which is a specific form of communication in the domain of HT D2D. Finally, there may be competition among multiple uncoordinated vehicles, requiring efficient algorithms for resolving contentions, similar to MMC.

As a second example of interaction, MMC features present two access modes that are relevant for D2D: the access through accumulation/aggregation point and the M2M communication through direct D2D link. However, this does not imply that one D2D solution can be reused; instead the interaction with MMC requires D2D communication that has minimized signalling overhead and poses a new type of problem: how to integrate low-rate D2D links within the system with a minimal overhead and power expenditure.

In the third example of interaction, the MN-N cluster concerns a flexible and demand-driven network deployment based on nomadic network nodes, and is clearly related to UDN in terms of

small cells deployment using wireless backhaul. On the other hand, nomadic nodes are instrumental for deployment of ad hoc infrastructure under emergency, which makes them a relevant technology from the viewpoint of URC-E. A technology that can complement the ad hoc infrastructure of nomadic nodes is direct D2D connectivity, making also D2D highly relevant for the emergency scenarios.

A fourth example is that URC-L has a strong link to HT UDN, since the dense deployment creates the challenge of guaranteeing certain moderate rate to a user that is available with high probability, e.g. 99.999% of the time. The UDN concept, taking into account the requirements of URC-L, can lead to innovative use of multiple TeCs.

Figure 3-15 summarizes the described interactions and synergies among the HTs.

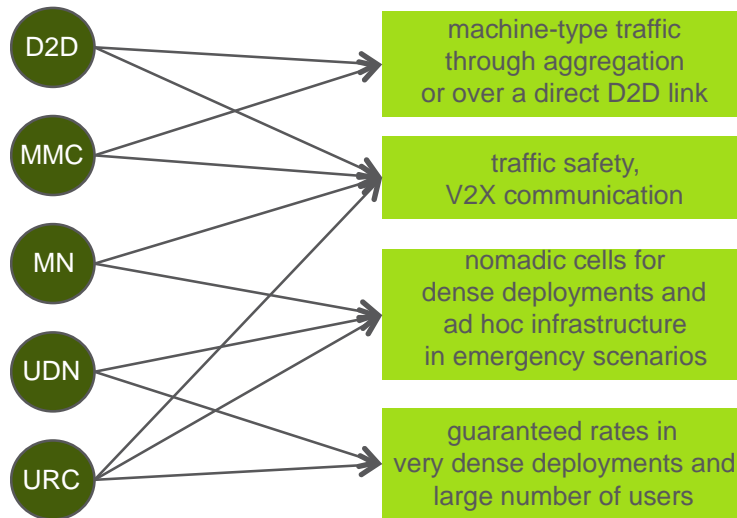

Figure 3-15: Examples of interactions and synergies among the HTs.

Based on the identified synergies, a number of development directions will be determined e.g. new air interfaces, common functions such as spectrum and mobility management, and architectural solutions that need to be developed to meet the METIS goals. These solutions will utilize the work already performed for the HTs and, the relevant TeCs.



## 4 Conclusions and future work

This deliverable documents the current status of the work done in the METIS project by the HTs integrating TeCs as developed by the WPs towards the METIS system concept. The selection of the five essential HTs D2D, MMC, MN, UDN and URC as done at the beginning of the project has been kept so far. The HT specific concepts have been described in detail and their most important aspects are highlighted below:

- In contrast to 3GPP work, the HT D2D concept is well integrated with METIS concept from the very beginning. Different TeCs are considered to meet various requirements in terms of increased link throughput, reduced latency and extended coverage. Re-configurable radio air interface can offer the best solutions targeted to different use cases. Interference management, resource allocation mobility management and other system level techniques enable the efficient D2D operation. In addition different relaying schemes can be used for the purpose of NW coverage extension or offloading. METIS D2D concept is able to provide solutions to solve various technical challenges resulting from both air interface level and network level.
- A crucial difference of the future 5G networks in comparison to existing 4G networks is that the system is from start designed not only for human-centric but also for machine-centric traffic. The machine-centric traffic will increase the number of connections far beyond that of human subscribers and the HT MMC concept will address this increase by: overlay of multiple transmissions (by means of quasi-orthogonal RA, sparse coding, successive interference cancellation, and reuse of resource by short-range links), smart pre-allocation of resources (persistent scheduling), techniques to lower the sync requirements and context/service-aware configuration of the radio access. In this way, one common flexible air interface supporting all types of machine communication will be provided for the three MMC access types: 1) direct access, 2) M2M access and 3) accumulation point access.
- The proposed HT MN concept goes far beyond the sole extension of current 4G technologies with regards to improved mobility support for mobile terminals. In fact, HT MN introduces two innovative and novel mobility concepts for future 5G networks that may have a significant impact on the future information society: (1) A technology toolbox that enables a flexible and dynamic network deployment based on nomadic nodes that allows for extending mobile networks based on capacity and coverage demands of the future information society. This concept may also serve as an enabler to provide on-demand/ad-hoc network infrastructure in disaster/emergency scenarios. (2) A system concept that enables vehicular networks based on mobile D2D and ultra-reliable communications, thus having the potential to significantly enhance road safety and traffic efficiency.
- In the case of UDN the core part of the concept is optimized for small ISD with virtually zero limitation of network density. It comprises tight collaboration of nodes w.r.t. resource sharing or self-backhauling schemes and fast (de-)activation and clustering mechanisms. The extended concept proposal includes additional features for the enhancement of UDN offering performance improvement by: 1) Context awareness for mobility and network management, 2) inter-RAT/ inter-operator collaboration, 3) tight interaction of the UDN with superior macro network including traffic offloading and enhanced resource scheduling, 4) macro site wireless backhaul for flexible UDN deployments.
- For the URC HT the concept of reliable service composition has been used to set the framework for building protocols and transmission techniques that can adaptively switch



to a lower grade of service (minimal connectivity) rather than failing the connection. A generic toolbox for achieving very high reliability consists of the following generic components: Spectrum allocation and management, robust PHY mechanisms, Signalling structure and interface management, Multi-RAT and reliable service composition. The innovation addressing the different URC problems in the corresponding HT concept is that they first redefine the actual optimization context for designing the TeCs and the associated performance parameters, such that a TeC or a group of TeCs can be shaped to support URC operation. For example, Massive MIMO can use the spatial degrees of freedom to guarantee the minimal rate of a given user instead of targeting the peak rate of the best users.

The HT concepts will be integrated towards the overall METIS system concept by further addressing the main technical goals of the project and encompassing evolutionary (w.r.t. legacy systems and standards) as well as revolutionary approaches. This has been shown in detail by drawing the first views on the 5G system envisaged by METIS in order to meet each technical goal by the corresponding methods and the relevant technologies.

In addition to the software simulations conducted at link and system level in the WPs, key building blocks of the METIS concept enabling the HTs will be show-cased by two test-beds for RRM and DBB. Recommendations for the implementation of relevant TeCs for the HTs have been given in this document.

The next steps of the work on the METIS system concept in the project include:

- Refinement of the HT definitions, based on their commonalities, for the further integration of their specific concepts with support of the METIS architecture.
- Definition of suitable development tracks for the further integration of the relevant TeCs researched by the WPs.
- Further evaluation of the METIS technical goals by evaluation criteria defined for 5G systems.
- Roadmap for the deployment of the METIS 5G system based on the evolution of legacy systems as well as the implementation of new applications.



## 5 References

[3GPP13-22278] 3GPP-22.278. "Service requirements for the Evolved Packet System (EPS)", v12.4.0. *3GPP TS 22.278*, September 2013.

[3GPP13-22803] 3GPP-22.803. "Feasibility study for Proximity Services (ProSe)", v12.2.0. *3GPP TR 22.803*, June 2013.

[3GPP14-23703] 3GPP-23.703. "Study on architecture enhancements to support Proximity Services (ProSe)", v1.1.0. *3GPP TR 23.703*, January 2014.

[3GPP13-36300] 3GPP-36.300. "Evolved Universal Terrestrial Radio Access (E-UTRA) and Evolved Universal Terrestrial Radio Access Network (E-UTRAN); Overall description; Stage 2 (Release 12)", v12.0.0. *3GPP TS 36.300*, December 2013.

[3GPP12-36836] 3GPP-36.836. "Mobile Relay for E-UTRA", v2.0.1. *3GPP TR 36.836*, October 2012.

[3GPP13-36843] 3GPP-36.843. "Feasibility Study on LTE Device to Device Proximity Services - Radio Aspects", v1.0.0. *3GPP TR 36.843*, November 2013.

[3GPP13-36888] 3GPP-36.888. "Study on provision of low-cost Machine-Type Communications (MTC) User Equipments (UEs) based on LTE (Release 12)", V12.0.0, *3GPP TR 36.888*, June 2013.

[3GPP11-36902] 3GPP-36.902. "LTE; Evolved Universal Terrestrial Radio Access Network (E-UTRAN); Self-configuring and self-optimizing network (SON) use cases and solutions", v. 9.3.1. *3GPP TR 36.902*, May 2011.

[5GrEEEn14] 5GrEEEn. <http://www.eitictlabs.eu/innovation-areas/future-networking-solutions/5green-towards-green-5g-mobile-networks/> viewed on March 31, 2014.

[BB09] Buvat, J. and Basu, S., "Operator OPEX strategies – How and where to cut costs," TME Strategy Lab, Nov 2009.

[COM13-D31] COMBO D3.1 "Analysis of key functions, equipment and infrastructures of FMC networks". *COMBO Deliverable 3.1*, November 2013.

[DK13] Devlin, J. and Konish, S., "Reducing Telecom Infrastructure CapEx and OpEx Costs Implementing Advanced Virtualization Techniques," LSI and Wind River, February 2013.

[Dini14] Dini Group. "DN9000K10PCI: Xilinx Virtex-5 Based ASIC Prototyping Engine". *The Dini Group*, 2014. <http://www.dinigroup.com/new/DN9000k10PCI.php> viewed on March 31, 2014.

[EAR12-D33] EARTH D3.3. "Final Report on Green technologies". *EARTH Deliverable 3.3*, July 2012.



[E309-D24] E3 D2.4. "Cognitive Function mapping to Networks Architectures, Standard Engineering and Software Technologies for Cognitive Radios". *E3 Deliverable 2.4*, December 2009.

[Ettus14] Ettus. "USRP networked series", *Ettus Research*, 2014.  
<https://www.ettus.com/product/category/USRP-Networked-Series>

[ETSI13] ETSI. "Network Functions Virtualisation – Network Operator Perspectives on Industry Progress". *ETSI ISG NFV (Operator Group)*, Updated White Paper, October 2013.  
[http://portal.etsi.org/NFV/NFV\\_White\\_Paper2.pdf](http://portal.etsi.org/NFV/NFV_White_Paper2.pdf)

[FFJ+14] Frenger, P., Friberg, C., Jading, Y., Olsson, M. and Persson, O. "Radio network energy performance: Shifting focus from power to precision," *Ericsson Review*, no. 2, February 2014.

[IEEE12-80211] IEEE 802.11. "IEEE 802.11-2012 Part11: Wireless LAN Medium Access Control (MAC) and Physical Layer (PHY) Specifications". *IEEE Standard*, March 2012.

[METIS14] METIS. *Homepage*. <https://www.metis2020.com/about-metis/project-structure/> viewed on March 31, 2014.

[MET13-D11] METIS D1.1. "Scenarios, requirements and KPIs for 5G mobile and wireless system". *METIS Deliverable 1.1*, April 2013.

[MET14-D12] METIS D1.2. "Initial channel models based on measurements". *METIS Deliverable 1.2*, to be published April 2014.

[MET13-D21] METIS D2.1. "Requirement analysis and design approaches for 5G air interface". *METIS Deliverable 2.1*, August 2013.

[MET13-D22] METIS D2.2. "Novel radio link concepts and state of the art analysis". *METIS Deliverable 2.2*, October 2013.

[MET14-D23] METIS D2.3. "Components of a new air interface – building blocks and performance". *METIS Deliverable 2.3*, to be published April 2014.

[MET13-D31] METIS D3.1. "Positioning of multi-node/multi-antenna transmission technologies". *METIS Deliverable 3.1*, September 2013.

[MET14-D32] METIS D3.2. "First performance results for multi-node/multi-antenna transmission technologies". *METIS Deliverable 3.2*, to be published April 2014.

[MET13-D41] METIS D4.1. "Summary on preliminary trade-off investigations and first set of potential network-level solutions". *METIS Deliverable 4.1*, September 2013.

[MET13-D51] METIS D5.1. "Intermediate description of the spectrum needs and usage principles". *METIS Deliverable 5.1*, August 2013.

[MET13-D61] METIS D6.1. "Simulation guidelines". *METIS Deliverable 6.1*, August 2013.



[Mit92] Mitola, J. "Software radios-survey, critical evaluation and future directions". *National Telesystems Conference*, May 1992.

[NGMN13] NGMN. "Suggestions on potential solutions for C-RAN". *NGMN Alliance*, White Paper, January 2013.

[OCF+13] Olsson, M., Cavdar, C., Frenger, P., Tombaz, S. and Jantti, R. "5GrEEEn: Towards Green 5G Mobile Networks". In *Proceedings of the IEEE International Conference on Wireless and Mobile Computing, Networking and Communications (WiMob 2013)*, October 2013.

[PWH13] Pentikousis, K., Wang, Y. and Hu, W. "Mobileflow: Toward software-defined mobile networks". *IEEE Communications Magazine*, vol. 51, no. 7, pp. 44-53, July 2013.

[PHK13] Phunchongharn, P., Hossain, E. and Kim, D. I. "Resource allocation for device-to-device communications underlying LTE-advanced networks". *IEEE Wireless Communications*, vol. 20, no. 4, pp. 91-100, August 2013.

[Str11] Ström, E. G. "On Medium Access and Physical Layer Standards for Cooperative Intelligent Transport Systems in Europe". *Proceedings of the IEEE*, vol. 99, no. 7, pp. 1183-1188, July 2011.

[TAZ+13] Tzanakaki, A., Anastasopoulos, M. P., Zervas, G. S., Rofoee, B. R., Nejabati, R. and Simeonidou, D. "Virtualization of heterogeneous wireless-optical network and IT infrastructures in support of cloud and mobile cloud services". *IEEE Communications Magazine*, vol. 51, no. 8, pp. 155-161, August 2013.

[Wal12] Walker, M., "A Growth Opportunity for Vendors: Telco Opex". OVUM, October 2012.

[WCT+14] Wang, X., Chen, M., Taleb, T., Ksentini, A. and Leung, V. "Cache in the air: exploiting content caching and delivery techniques for 5G systems". *IEEE Communications Magazine*, vol. 52, no. 2, pp. 131-139, February 2014.

[XILINX09] XILINX. "Virtex-5 Family Overview: Product Specification". XILINX, product specification, February 2009.

[http://www.xilinx.com/support/documentation/data\\_sheets/ds100.pdf](http://www.xilinx.com/support/documentation/data_sheets/ds100.pdf)



**Document:** FP7-ICT-317669-METIS/D6.2

**Date:** 01/04/2014

**Security:** Public

**Status:** Final

**Version:**

---

# Annex





**Document:** FP7-ICT-317669-METIS/D6.2

**Date:** 01/04/2014

**Security:** Public

**Status:** Final

**Version:**

---



## 6 Annex: Test-beds

### 6.1 Test-bed purpose

As described in Section 3, each HT builds a specific concept comprising new functionalities by integrating relevant TeCs from WPs. To complement the design work, METIS has two hardware test-beds at its disposal. The purpose of the test-beds is to demonstrate key TeCs enabling the HTs using hardware platforms, and to show-case the system concept.

The test-beds will complement simulations and evaluations performed in WPs 2 to 5, and at system level [MET13-D61]. The test-beds will evaluate aspects that are hard to verify through software simulations, e.g. processing delays, control signalling, and hardware implementation complexity and impairments. The test-bed evaluation results will be considered when evaluating the final METIS system concept.

### 6.2 Test-bed overview

#### 6.2.1 Radio Resource Management test-bed

The Radio Resource Management (RRM) test-bed is designed for investigation of RRM algorithms in realistic radio environments. The test-bed consists of 24 software radio nodes that communicate over the air. Each software radio node consists of a Universal Software Radio Peripheral (USRP) based radio front-end [Ettus14] and a computer controlling the hardware and running the RRM algorithms under evaluation and other radio-related software. The USRP units can transmit 100 mW at any frequency in the interval 0.4 to 4.4 GHz using a maximum signal bandwidth of 20 MHz. A frequency license for transmission in 620 to 650 MHz exists, or an 8-channel radio channel simulator can be used.

This test-bed is suited for implementation, evaluation and demonstration of TeCs related to e.g. RRM, TDD transmission, LSA, and D2D.

#### 6.2.2 Digital Baseband test-bed

The Digital Baseband (DBB) test-bed is designed for investigation of digital base-band algorithms. The test-bed consists of high-capacity prototyping DSP boards [Dini14], integrating 6 FPGA Xilinx Virtex 5 LX330 [XILINX09], and a host computer used for control and displaying performance results. Other prototyping boards based on the latest Xilinx Zynq-7000 All Programmable System on Chip (SoC) are available. The generated signal can either be transmitted via the air or via a channel simulator. In addition to the hardware resources, all required hardware and software development tools, methodologies, and design expertise is available.

This test-bed is suited for implementation, evaluation and demonstration of TeCs related to high-throughput, flexible, energy- and cost-efficient air interfaces, e.g. coding/decoding, modulation, and MIMO techniques.

#### 6.2.3 Implementation decisions

A call for proposals of TeCs to implement on the test-beds described above was held in METIS. The proposals were evaluated with respect to technology impact (relevance to the scenarios/test cases, best supporting the HTs and overall system concept), publicity impact, and feasibility.

For the **RRM test-bed** it is decided to implement the proposal “Direct network controlled device to device communication with interference cancellation” targeting the integration of cellular and



**Document:** FP7-ICT-317669-METIS/D6.2

**Date:** 01/04/2014

**Security:** Public

**Status:** Final

**Version:**

---

D2D systems. The proposal tests the impact of the D2D interference to the cellular link, clock and frequency error impact on the performance, and RRM algorithms, scheduling properties. This proposal is relevant to all scenarios utilizing D2D and e.g. TC2, TC3. This proposal is also relevant to HT URC.

For the **DBB test-bed** it is decided to implement the proposal “FBMC/OQAM new waveform” evaluating potential gains of a new air interface. The proposal tests improved spectrum utilization through reduced side-lobes, and robustness against Doppler shifts for mobile terminals. It designs and tests efficient low-complexity hardware implementations of the new air interface. The proposal is relevant for HTs D2D, MN, URC in e.g. TC2 and TC12.



## 7 Annex: METIS test cases

In deliverable D1.1, [MET13-D11], twelve different Test Cases (TCs), were selected to represent the identified problem space for which METIS will fulfil the overall technical goals by providing a system concept. Based on this deliverable, we here present a brief description of each test case.

**TC1**, the Virtual reality office, is where really high data rates are sought, while fulfilling capacity needs at reasonable cost, in an indoor environment.

**TC2**, the Dense urban information society, is where really high traffic volumes and high experienced data rates are needed at a reasonable cost, in an urban environment.

**TC3**, the Shopping mall, is where high traffic volumes, high experienced user data rates, and good availability are needed in a shopping mall.

**TC4**, the Stadium, is where good network experience is needed by users in a stadium.

**TC5**, the Teleprotection in smart grid network, is where low latency and high reliability are needed.

**TC6**, the Traffic jam, is where good network experience is sought by in-vehicle users stuck in a traffic jam.

**TC7**, the Blind spot, is where vehicles can provide capacity in blind spot areas in a flexible, energy and cost efficient manner.

**TC8**, the Real-time remote computing for mobile terminals, is where high data rates and low latency are needed for terminals on the move.

**TC9**, the Open air festival, is where a highly under-dimensioned network needs to be complemented for a shorter time period in a cost efficient manner.

**TC10**, the Emergency communications, is where only some infrastructure remain in an urban environment, e.g. after a disaster, and where the basic communication is maintained by the regular devices.

**TC11**, the Massive deployment of sensors and actuators, is where a large number of connected, energy efficient, and low cost devices occasionally communicates.

**TC12**, the Traffic efficiency and safety, is where high reliability and availability, together with low latency, are needed in order to increase the automotive efficiency and safety.



## 8 Annex: METIS Horizontal Topics

### 8.1 HT Moving Networks: Definition of HT MN Clusters

The HT MN will bundle the research activities with respect to moving/nomadic networks into three main Clusters, which are defined as follows:

- **MN for mobility-robust high-data rate communication links (MN-M)**
  - Description: Moving relays (e.g. vehicles that provide communication capabilities for terminals inside the vehicle, such as trains, busses, trams and cars) and conventional mobile terminals require high-data rate and low-latency communication links in order to support future services such as augmented reality and virtual office applications at high speeds.
  - Key Requirements: High-data rate and low latency communication links
  - Related WP1 Test Cases [MET13-D11]: TC6, TC8
- **MN for nomadic network nodes (MN-N)**
  - Description: Nomadic network nodes that serve for a flexible and dynamic network deployment based on service, capacity, and coverage demands. Such nomadic nodes require robust and high-data rate backhaul links.
  - Key Requirements: Robust and high-data rate communication links
  - Related WP1 Test Cases [MET13-D11]: TC6, TC7, TC10
- **MN for V2X communications (MN-V)**
  - Description: Novel V2X and driver assistance services require cooperation between vehicles and between vehicles and its environment (e.g. vulnerable road users with smartphones) in order to improve road safety and traffic efficiency in the future. Such V2X services require reliable communication links that enable the transmission of data packets with guaranteed maximum latencies even at high vehicle speeds.
  - Key Requirements: Low/Medium-data rate, low latency, and high reliable communication links
  - Related WP1 Test Cases [MET13-D11] TC10, TC12

### 8.2 Description of HT Ultra Reliable Communication

#### 8.2.1 Reliability Aspects

In general, the reliability of a given connection can be deteriorated due to one of the following five reliability aspects (RLA):

RLA1. *Decreased power of the useful signal*. This encompasses the aspects that the communication system cannot control: mobility, fading, etc. The system has to cope with these impairments through suitable modification of the coding and modulation scheme and/or the protocol.

RLA2. *Increased uncontrollable interference*. It may refer to interference from a different system in the same band, as it is with the unlicensed operation, or interference from the same type of system that is not controllable (for example, D2D transmission in the same licensed band).

RLA3. *Resource depletion due to competing devices*. This refers to the problem in which multiple devices are trying to share the communication resources in the same system. Specifically, at the UL radio access it is represented by contention, but the resource depletion can be more general and emerge at other layers as well. Furthermore, resource depletion can happen both in DL and UL. In DL the



infrastructure has a complete control over the allocation of resources and it can reach the allocation limit if too many devices need to be served. One may be lead to think that this is straightforward: for example, if the DL capacity is 100 Mbps, then if there are 100 devices, then each of them can get at most 1 Mbps. However, due to different aspects, such as overhead and channel variation across the devices, we cannot guarantee that the same system with 100 Mbps can serve a particular group of 150 devices in which each device gets 600 kbps, although  $600 \times 150 = 90$  Mbps. In the UL the problem is even more aggravated, due to the lack of coordination across the devices and resource wastes due to collisions, back-off, etc. In short, it is not only important the overall capacity of the system, but also the flexibility and the granularity of the resources that can be allocated to the devices. This is of great importance for the scenarios that involve e.g. MMC or UDN.

RLA4. *Protocol reliability mismatch.* This captures the suboptimal protocol operation in certain conditions with decreased reliability. Consider the following example: Signalling information is usually very robustly encoded, such that under normal operating conditions it can be received correctly almost with probability 1. Representatives of such information are the beacons, the packet headers, various poll/response packets, heartbeat mechanisms, etc. When the receiving conditions are worsening, this information starts to be received with errors. Usually the systems are good to adapt the transmission rates for the actual data to the current channel conditions, but the transmission of the signalling information stays largely non-adaptive.

RLA5. *Equipment failure.* This is primarily related to disaster/emergency scenarios, where part of the infrastructure becomes dysfunctional.

### 8.2.2 The Problem of Reliable Service Composition

The ultimate goal of a communication system is to ensure reliable transfer of the data as perceived by a certain service/application, residing in the highest layer of the communication system. All the other procedures can be seen as auxiliary building blocks towards building such a reliable communication for the application layer. Following the layered paradigm in designing communication systems, the reliability requirements (latency, data rate, error probability) at the higher layers are translated into reliability requirements to each of the lower layers. However, such a systematic mapping of the reliability requirements into the lower layers is necessarily putting conservative requirements to the lower layers, as the following example shows.

Consider a cloud computing service that has latency requirement set at the application layer in a way that the user has the perception that the computing/memory resources are local. Let that latency be set to, e.g. 0.5 seconds. The latency figure itself does not specify the amount of data that needs to be transferred during that time, such that one needs to reckon with the highest amount of data that needs to be transferred in that period. However, adjusting the system only to the highest data volume will lead to prohibitively high rate requirements that are very difficult to satisfy: Either the system has to pre-reserve those resources and have them idle most of the time or the service needs to accept certain degradation in the originally requested service. In practice, the second one is a viable solution in order to keep high system efficiency while providing a satisfactory level of reliability.

The concept of URC implies that a certain guarantee of some of the service parameters is of paramount importance. However, having rigid reliability requirements, such as “*transfer of data*



*packets that have at most  $B$  bytes with a delay  $D$  less than  $L$  seconds in 99% of the attempts*“ creates a rather simple criterion for us to conclude whether the reliability requirement is met or not. But the real question is: Does the service need to fail whenever the reliability requirement is not met? In order to answer “no” to this question, we need to reconsider the *service composition* and allow graceful degradation of the service, instead of making a binary decision “service available/not available”.

To motivate this further, let us compare the classical concepts used in system reliability engineering with the concept of wireless link reliability. In a classical setting, the system can be in a binary state (1) up and operating and (2) down or in failure. Two important parameters of the system are Mean Time Between Failures (MTBF) and Mean Time To Repair (MTTR). On the other hand, one defines the reliability of a wireless link through its Outage Rate Probability (ORP), as done in [MET13-D21], which is the probability that system cannot reach a certain data-rate at a given QoS. However, it is crucial to note that, when the system is in outage, it supports a lower data rate at a certain QoS/error probability. If a service that uses such a link needs to have exceptionally high reliability, then, instead of only looking how to improve the link or find other connectivity modes to transfer the data, we can also look in the composition of the service and define composite QoS/QoE, such as one or more degraded variants of the same service. For example, in a vehicular communication environment, if a congested situation is detected, then the system may decide to send only the critical messages that are used to coordinate with the other vehicles or with the infrastructure.



## 9 Annex: HT concepts

### 9.1 HT Moving Networks

#### 9.1.1 Definition of Mobility Aspects

The HT MN provides a concept extending across three clusters, see Annex, Section 8.1. In order to better identify the main challenges faced by the clusters and evaluate the TeCs accordingly, four mobility aspects have been defined within the context of the HT MN. The mobility aspects cover the main challenges related to the HT MN across all the test cases specified within the METIS project. For each mobility aspect, a series of KPIs has been selected to evaluate the degree of improvement achieved by the TeCs. The four mobility aspects together with the related KPIs are:

- **MA1 – Link level performance in mobile channels:** this mobility aspect copes with the impairments of the mobile propagation channel, in particular the Doppler shift caused by the relative movement between communication pairs and the rapid variations of the received signal strength over time due to multipath (i.e. fast fading). In this context, **new waveforms and channel equalization techniques** can improve the robustness against the Doppler shift whereas advanced **channel coding, link adaptation and HARQ mechanisms** can exploit the presence of fast fading. Furthermore, this aspect also considers **multi-node and multi-antenna techniques** aimed at improving the user throughput and the system capacity while being robust to the imperfect channel knowledge that results from highly mobility. This mobility aspect can be measured by the following KPIs:
  - **Experienced user throughput in relation to the user velocity** (60 km/h, 120 km/h, 250 km/h, times two to get the relative speed between communication pairs in D2D). The experienced user throughput is measured according to the definition in [MET13-D11]: data throughput that an end-user device achieves on the MAC layer (user plane only) averaged during a predefined time span. This metric is one possible measure for the quality of experience (QoE) level a user experiences for the service applied. However, the data rate of the service application itself is lower than the experienced user throughput as additional protocol overhead and/or traffic control on higher layers, e.g. PDCP and RLC at LTE, IP, TCP/UDP/SCTP). The experienced user throughput depends on the test case environment, but also on the number of users and the amount of data they generate, because they affect the cell load and interference from surrounding cells in a radio network.
  - **MAC latency in relation to the user velocity** (60 km/h, 120 km/h, 250 km/h, times two to get the relative speed between communication pairs in D2D). The MAC latency is measured according to the definition of GRM4 in [MET13-D21]: time elapsed between the following two occasions: 1) the transmitter MAC receives a packet from its upper layer; 2) the receiver MAC delivers the packet to its upper layer. A packet that, for some reason, is never delivered is called a dropped packet. Dropped packets are considered to have infinite delay. Furthermore, note that if the MAC (or layers below it) uses retransmission schemes, the retransmission delays are, by definition, included in MAC latency.
  - **Packet error rate/reliability/integrity in relation to the user velocity** (60 km/h, 120 km/h, 250 km/h, times 2 to get the relative speed between communication pairs in D2D). The packet error rate is measured according to the definition of





GRM5 in [MET13-D21]: probability that a packet that is received by the transmitter MAC from its upper layer is not delivered to the receiver MAC upper layer. Reliability is measured according to the definition of GRM5 in [MET13-D21]: probability that a packet that is received by the transmitter MAC by its upper layer is delivered by the receiver MAC to its upper layer error-free and with MAC latency, GRM4, below a certain defined deadline. Integrity is measured according to the definition of GRM5 in [MET13-D21]: probability that a packet that is delivered from the receiver MAC to its upper layer and whose MAC latency, GRM4, is below a certain deadline is error-free.

- **MA2 – Handover and cell reselection:** the focus of this mobility aspect is the upper layer management of moving cells and devices. It aims at guaranteeing a seamless connectivity and improved quality of service, while users or cells are moving through the network. **Handover prediction and optimization** is an essential technique to keep the best connectivity of users and the backhaul link of moving cells. Moreover, the densification of moving and nomadic cells raises challenges on **cell reselection and handover management** (i.e. in-bound/out-bound mobility) since users will rapidly traverse cells. This mobility aspect can be measured by the following KPIs:
  - **Handover failure probability** defined as the probability of a radio link failure (RLF) caused by any of the following reasons:
    - Too late handover: a RLF occurs in the source cell before the handover or during the handover procedure. After that, the UE re-establishes the connection in a different cell than the source cell.
    - Too early handover: a RLF occurs short time after the UE successfully connects to the target cell. After that, the UE re-establishes the connection in the source cell.
    - Handover to the wrong cell: a RLF occurs short time after the UE successfully connects to the target cell. After that, the UE re-establishes the connection in a cell other than the source or the target cell.
  - **Handover rate** defined as the number of handovers that are performed per second.
  - **Signalling overhead** defined as the ratio between the amount of signalling information that is transmitted due to handover and cell reselection and the total amount of information that is transmitted (signalling plus payload).
  
- **MA3 – Management of nomadic and moving cells:** the focus of this mobility aspect is the radio resource management of nomadic (and moving) cells. In this context, the **dynamic de-/activation of nomadic (moving) cells** is a promising technique to provide additional capabilities for energy saving and load balancing for the network. Furthermore, **interference management and advanced cooperative strategies** are the key enablers to provide diversity and capacity enhancement to the network. This mobility aspect can be measured by the following KPIs:
  - **Experienced user throughput in relation to the moving cell velocity** (60 km/h, 120 km/h, and 250 km/h). The experienced user throughput is measured according to the definition in [MET13-D11]: data throughput that an end-user device achieves on the MAC layer (user plane only) averaged during a predefined time span. This metric is one possible measure for the quality of experience (QoE) level a user experiences for the service applied. However, the data rate of



the service application itself is lower than the experienced user throughput as additional protocol overhead and/or traffic control on higher layers, e.g. PDCP and RLC at LTE, IP, TCP/UDP/SCTP). The experienced user throughput depends on the test case environment, but also on the number of users and the amount of data they generate, because they affect the cell load and interference from surrounding cells in a radio network.

- **Traffic volume density** according to the definition in [MET13-D11]: total user data volume transferred to/from end-user devices during a predefined time span divided by the area size covered by the radio nodes belonging to the RAN(s). For multi-hop solutions each user data is only counted once.
  - **Spectrum efficiency** following the definition of GRM1 in [MET13-D21]: ratio between the time-averaged aggregate throughput of a set of users or users in a given area, such as under a certain cell, and the bandwidth. For multi-hop solutions each user data is only counted once.
  - **Network energy efficiency** (infrastructure and UEs/devices) defined according to the metrics defined in [MET13-D11] at network level: energy per information bit (W/bps) and power per unit area (W/m<sup>2</sup>).
  - **Signalling overhead** defined as the ratio between the amount of signalling information that is transmitted due to nomadic and moving cell management and the total amount of information that is transmitted (signalling plus payload).
- **MA4 – Enablers of mobile D2D:** this mobility aspect considers highly mobile vehicular terminals for D2D. This leads to a short channel coherence time and render the collection and reporting of up-to-date Channel State Information (CSI) more complicated (or maybe infeasible with reasonable effort). Hence, it is crucial to find **RRM and MAC techniques** that allow for satisfactory communication performance, provided limited or no CSI knowledge. Moreover, the time intervals during which a particular vehicular terminal stays in a certain area are expected to be very short due to the high mobility. Hence, **device and service discovery schemes** need to be carefully defined considering the time to discovery, the number of discoverable devices/services and the required signalling overhead. This mobility aspect can be measured by the following KPIs:
    - **Maximum supported number of connections** according to the definition in [MET13-D21]: maximum supported number of D2D connected user equipments (UEs)/devices, where a connection can be defined by accounting for a certain minimal QoS parameters.
    - **Fairness** according to the definition in [MET13-D21]: distribution of the user throughput (e.g. by means of a cumulative distribution function), which is different from the sum cell throughput.
    - **Availability** according to the definition in [MET13-D21]: percentage of users for which a certain quality of service QoS requirement is met.
    - **Time to discovery** defined as the time span that is needed to discover the presence of a communicating D2D pair and establish the D2D communication.
    - **Number of discoverable devices** defined as the maximum number of discoverable devices/services per mobile node within a certain time span.
    - **Signalling overhead** defined as the ratio between the amount of signalling information that is transmitted due to D2D discovery and mobility management and the total amount of information that is transmitted (signalling plus payload).



## 9.1.2 Additional Information on the Concept of MN for Mobility-Robust High-Data Rate Communication Links (MN-M)

### 9.1.2.1 Technology components addressing MN-M

#### 9.1.2.1.1 WP2

WP2 has produced a number of Technological Components Clusters (TeCC) as a result of clustering the different TeCs being investigated in the work package. The following TeCCs [MET14-D23] have been identified as relevant for the MN-M cluster:

- *TeCC #6 – Air interface of moving networks:* the framework for URC included in the TeCC is aimed at guaranteeing the availability of an ultra-reliable link and at reliably indicating the non-availability to the application. On the other hand, advanced channel estimation and predictions techniques are expected to improve the system robustness against Doppler and fast fading in highly mobile scenarios.
- *TeCC #8 – Filtered and filter-bank based multi-carrier:* the use of filtered (TeCC #8.2: UFMC a.k.a. UF-OFDM) and filter-bank (TeCC#8.1: FBMC) based multi-carrier could improve the transmission robustness against Doppler in high mobility scenarios by adapting the waveform to the UE characteristics and the propagation scenario. Furthermore it is also possible to enable the concurrent support of multiple speed classes without the need for compromising between the different device and mobility classes. The adaptation between different speed classes is possible on a per sub-band level (e.g. a single PRB in LTE terminology) enabling the system to be highly scalable.
- *TeCC #9.2 – Advanced coding and decoding:* within this TeCC, new error estimation techniques are investigated in order to reduce the latency of channel decoding algorithms. On one hand, the framework on lattice codes is focused on short block lengths and, hence, constitutes a baseline for the reduction of the transmission and reception delays. On the other hand, the framework on the flexible complexity trade-offs is relevant for the concept for the MN-M cluster as it allows for the optimization of the processing delays with respect to channel conditions and data rates.

#### 9.1.2.1.2 WP3

The following TeCs belonging to WP3 [MET13-D31] have been identified as relevant for the MN-M cluster:

- *T3.1 – TeC #6 - Adaptive Large MISO Downlink with Predictor Antenna Array for very fast moving vehicles:* A new scheme called Separate Receive and Training Antennas (SRTA) with antenna Switch Off Scheme (SOS) is proposed specifically for large MISO downlink beam forming (BF) in TDD. The objective is to achieve high energy efficient wireless backhaul for fast moving vehicular relays. The vehicle roof is equipped with one predictor antenna (PA) at the front and several “Candidate Antennas” aligned behind the predictor antenna. Among the CAs, one Receive Antenna (RA) is selected dynamically to compensate BF mis-pointing due to speed. SOS dynamically reduces the BS array aperture and hence the beam width to cope with residual BF mis-pointing.
- *T3.2 – TeC #16 – Non-coherent transmission:* This TeC investigates the use of non-coherent detection mechanisms to minimize the waste of resources due to the use of reference signals, at the expense of a certain performance loss. The use of non-coherent techniques is also expected to increase the system robustness against imperfect CSIR in scenarios with medium or high mobility.
- *T3.3 – TeC #9 - Studies of deploying moving relay nodes:* By using D2D communication and cooperating with each other, less energy is required to send the same amount of



data of each active vehicular UE in the cooperative transmission than the individual vehicular UE-to-BS communications.

### 9.1.2.1.3 WP4

The following TeCs in WP4 [MET13-D41] have been identified as relevant for the MN-M cluster:

- *T4.1-TeC1-A1 - Adaptive Projected Sub-gradient Method (APSM):* This TeC supports resource allocation schemes by using an adaptive projection algorithm for the estimation/identification of long-term interference couplings between Base Stations (BSs) and users. The identified couplings can be utilized while accessing or allocating orthogonal resource blocks to the users. The ability to apply a better resource allocation scheme can potentially improve the robustness of highly mobile communication links.
- *T4.1-TeC1-A2 - Minimum Mean Square Error (MMSE) Estimation:* This method uses a statistical estimation approach that combines the measurements with statistical knowledge of measurement uncertainty, and prior knowledge of spatial correlation between the interference links. This will help identify the interference in the system and, as an aid to resource allocation schemes, could lead to more robust communication links in highly mobile scenarios.
- *T4.1-TeC1-A3 - Interference Identification using multi-layer inputs:* By combining inputs from several network points, a semi-centralized mechanism for identifying potential sources of interference is being proposed. The scheme is based on inputs from UEs, and (H)eNBs for shortlisting the interferers and proceeding in the proper interference handling actions. It could aid the system towards an improvement of the latency (by avoiding unnecessary retransmissions), and robustness (due to identification of the interference sources) on highly mobile communication links.
- *T4.1-TeC8 - Resource allocation scheme for moving relay nodes:* The objective of this work is to evaluate the performances when applying the existing ICIC schemes on moving networks in order to identify whether new ICIC methods specifically designed for moving cells are needed. The work will also study the possibility of implementing full-duplex in-band MRNs for scenarios using different bands for the backhaul link and access link. In the context of MN-M, full duplex MRNs can relax the scheduling burden for certain traffic types and allow for lower delays.
- *T4.2-TeC1 - Optimized distribution scheme for context information:* This technical component aims to develop an efficient management and exchange mechanism for the context information. The available context information will be used to improve the performance of the mobile links considered by MN-M.
- *T4.2-TeC2 - Context awareness through prediction of next cell:* based on observed user movement patterns, e.g. daily commuters travelling in buses, trains, etc., it is possible to predict user trajectories and the next cell for transition. This TeC aims at improving handover processes and enables pro-active RRM, thus enhancing reliability, availability, scalability, and efficiency. It can, hence, contribute towards meeting the mobility requirements posed by MN-N.
- *T4.2-TeC6 - Handover optimization using street-specific context information:* This scheme exploits street-specific context information (e.g. route information, vehicle speed) in order to decrease handover failures. By reducing handover failures for moving devices, such as vehicles, the robustness of the communication links can be significantly improved.
- *T4.2-TeC7 - Context aware mobility handover optimization using Fuzzy Q-Learning:* Optimization of the handover process according to the locally observed network



performance should decrease the number of handover failures, connection dropping, ping pong handovers, etc. Hence it should increase the robustness of communication links in the scenarios considered within the MN-M cluster.

- *T4.2-TeC9 - Smart mobility and resource allocation using context information:* This TeC investigates resource allocation for users moving according to a fixed road topology based on context information. In consequence, the network can operate in a smarter manner improving the performance of highly mobile users.
- *T4.2-TeC10 - Signalling for trajectory prediction:* this TeC relies on T4.2-TeC2 for providing prediction of next cell for user transition and facilitates network-wide information exchange, e.g. indicating arrival of UE into predicted cell. Such information could be exploited to make smart resource management decisions for vehicular users and reduce blocking, dropping of users, and handover failures.
- *T4.3-TeC1-A2 - New management interfaces for information exchange and action enforcement:* This TeC is enabler to other TeCs by describing the interfaces required for information exchange and action enforcement.

#### 9.1.2.1.4 WP5

The following TeC in WP5 has been identified as relevant for MN-M. Moreover, a preliminary analysis has been performed regarding the particularities of the MN-M cluster with regards to spectrum access and bandwidth demands (see [MET13-D51]):

- *Flexible spectrum use for MN:* This TeC increases the probability of finding interference-free spectrum and provides better reliability and global concept support. Moreover, MMW utilization is possible which may be useful due to the easy support of pen-like antenna characteristics for backhaul links. Adaptive steering solutions for mmW that allow fast tracking of objects (e.g. cars) have been successfully demonstrated. Hence, this TeC could contribute towards the fulfilment of the requirements posed by MN-M.

#### Spectrum Access Analysis

- Dedicated spectrum has to be used in the link between mobile terminal antenna (e.g. a vehicle roof-top antenna) and macro base station
- For capacity enhancement (or in case enough dedicated spectrum cannot be found) LSA authorisation should be the way forward.
- If the vehicle serves as a moving relay for in-vehicular coverage:
  - Unlicensed spectrum can be used for connecting end users to wireless gateway. Nowadays, 2.4 GHz could be an option. In future higher frequencies (e.g. 60 GHz) could be used to meet performance target at high user densities (e.g. inside trains and busses). Unlicensed bands can also be used for local information exchange between users inside the vehicle.

#### Bandwidth and Frequency Range Aspects

- Roughly 500 MHz of bandwidth is needed for high-mobility terminals.
- Frequencies could be found below 10 GHz. This spectrum is suitable for mobile services with real-time constraints. For example, 5925 – 6425 MHz (500 MHz) could be an option.
- Higher frequencies could be used for in vehicle communication (e.g. 60 GHz).



### 9.1.2.2 Concept analysis of MN-M based on Mobility Aspects

In order to analyse the concept of the MN-M cluster we evaluate each one of the mobility aspects that cover the main challenges faced by this cluster with respect to mobility. As can be seen in Table 9-1, the main challenges of MN-M are covered by Mobility Aspect 1 – Link level performance in mobile channels, Mobility Aspect 2 – Handover and cell reselection, and Mobility Aspect 3 – Management of nomadic and moving cells.

Table 9-1: Analysis of mobility aspects in MN-M.

Mobility aspect 1	<b>Link level performance in mobile channels:</b> this aspect is of great relevance for MN-M due to the high velocity of devices, which results in very high Doppler shifts and very fast varying channels. In this sense, the concept has to incorporate at the physical and MAC layers mechanisms to improve the robustness against Doppler and fast varying channels (e.g. lack of accurate channel information).
Mobility aspect 2	<b>Handover and cell reselection:</b> This aspect has an important impact in MN-M, especially when it comes to very fast HO with extremely short service interruption times. Exploitation of context information and interference estimation techniques can assist the network when selecting the best suitable access node (i.e. macro base station, micro base station, relay, etc.).
Mobility aspect 3	<b>Management of nomadic and moving cells:</b> this is a key aspect in MN-M since improving the end-to-end link between base station and terminals is essential for the achievement of high data-rates with low latency.
Mobility aspect 4	<b>Enablers for mobile D2D:</b> this aspect is not relevant to MN-M as mobile D2D communication is not considered as part of the concept.

#### Mobility Aspect 1: Link level performance in mobile channels

Figure 9-1 shows a detailed version of the concept for MN-M addressing MA 1. The concept revolves around the air interface for moving networks (WP2 TeCC #6), which extends across both L1 and L2. This TeCC includes the Framework for URC as well as new channel prediction and estimation techniques which are expected to improve the robustness against the effects of high mobility and enable QoS control on the link level. In complement, WP2 - TeCC #8.1, WP2 - TeCC #9.2, WP2 - TeCC #10.1, WP2 - TeCC #13, and WP3-T3.1-TeC #6 investigate new waveforms, coding and decoding techniques, and transceivers architectures in order to improve the robustness against Doppler effects and fast fading. The framework for URC will use the inputs from these TeCCs to estimate and indicate the availability of an ultra-reliable link to upper layers and to configure the transmission in order to maximize the availability of the ultra-reliable link according to the QoS requirements (e.g. packet size, error probability, latency, etc.).

On the other hand, WP3 – T3.2-TeCC #16 provides non-coherent detection mechanisms for the more efficient utilization of radio resources. However, this comes at the expense of a certain performance loss which should also be taken under account by the framework for URC in order to satisfy the requirements posed by MN-M.

More information on the TeCs can be found in [MET14-D23; MET13-D31].

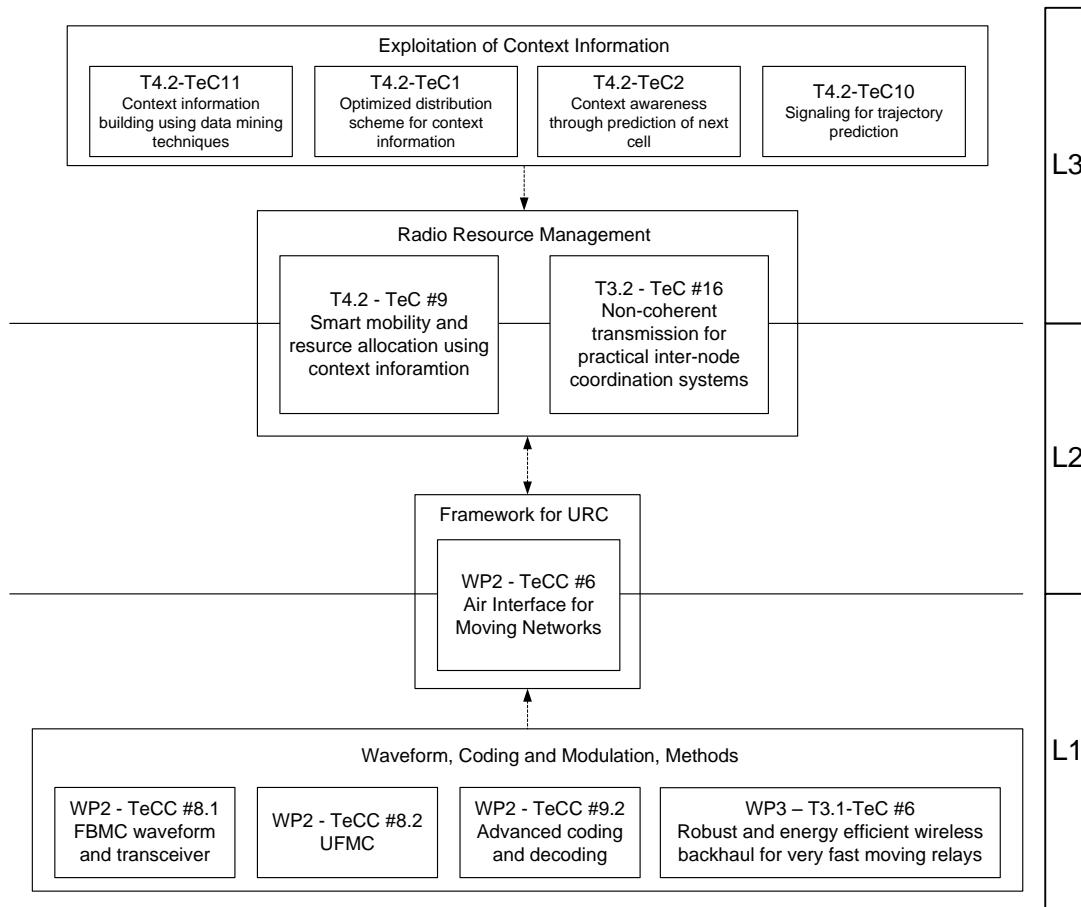

Figure 9-1: Detailed concept for MN-M covering Mobility Aspect 1.

### Mobility Aspect 2: Handover and Cell-Reselection

Figure 9-2 shows a detailed version of the concept for MN-M addressing MA 2. It revolves around a core of handover optimization mechanisms designed to realize better performance by exploiting context information.

Towards the satisfaction of the requirements posed by MN-M, WP4 - T4.2-TeC6 focuses on tuning the handover parameters for enhanced robustness. T4.2-TeC7 exploits a wide range of context information (network load, QoS, etc.) in order to realize seamless handover in a heterogeneous network using a fuzzy logic approach.

Both handover mechanisms rely on additional L3 components for the retrieval of context information. Hereby, WP4 - T4.2-TeC1 WP – T4.2-TeC2, and WP4 - T4.2-TeC10 focus on how to collect, predict, and distribute the useful context information based on lower level measurements. Moreover, WP4 – T4.2-TeC11 aims at building context awareness based on model learning.

Complementary information on the interference environment is provided to the handover mechanisms by WP T4.1-TeC1. Hereby, WP4 – T4.1-TeC1-A1 aims at the identification of long-term interference couplings in the network, WP4 – T4.1-TeC1-A2 uses additional statistical information towards a more accurate assessment of the interference environment, and WP4 –

T4.1-TeC1-A3 identifies potential interferes by performing signal processing to the physical layer measurements from multiple points in the network.

More information on the TeCs can be found in [MET13-D41].

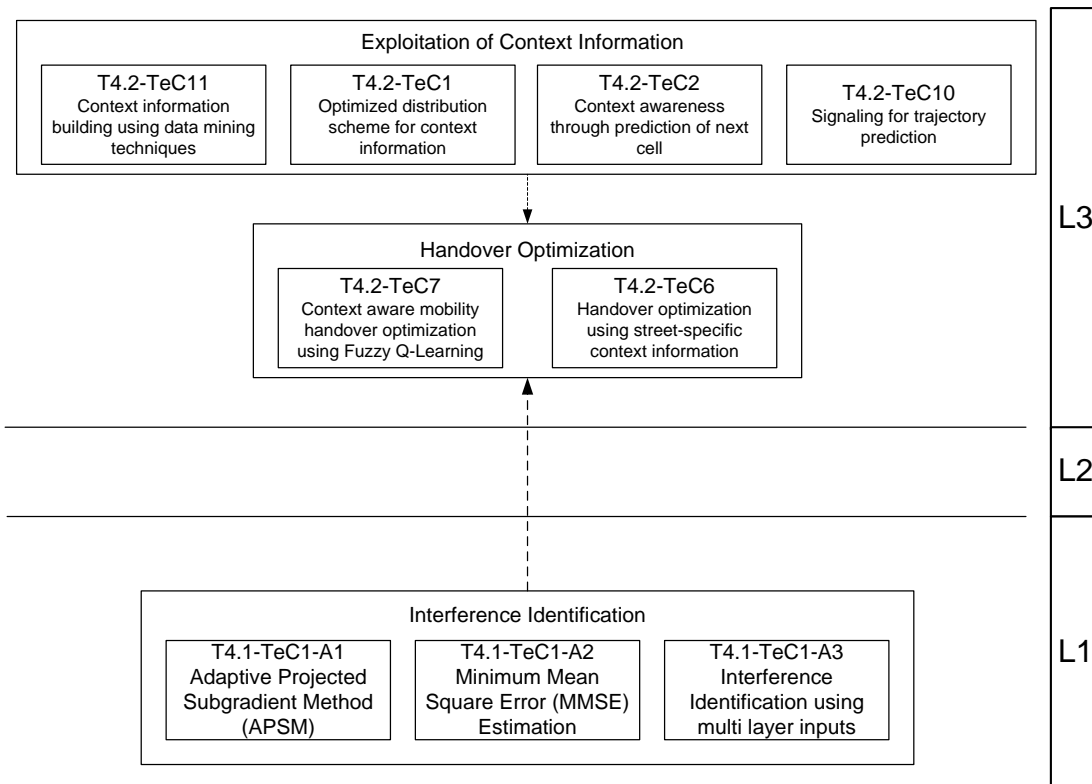

Figure 9-2: Detailed concept for MN-M covering Mobility Aspect 2.

### Mobility Aspect 3: Management of Nomadic and Moving Cells

Figure 9-3 shows a detailed version of the concept for MN-M addressing MA 3. A crucial task in providing high capacity and low latency links is the choice of an appropriate access point for the mobile terminals. In this context, nomadic and moving cells represent an important network aspect that could help achieve the desired performance. Therefore, the concept is built around a core of RRM an activation\deactivation schemes situated across L2 and L3. Two core TeCs have been identified as particularly well suited to the requirements of MN-M. On the one hand, WP4 - T4.1-TeC8 investigates new ICIC methods specifically designed for moving cells in order to improve the spectral efficiency of the transmissions. On the other hand, WP4 - T4.3-TeC3-A2 enables dynamic nomadic node selection for the optimization of the backhaul link in terms of SINR, link rate, and end-to-end delay.

Those two core components benefit from the exploitation of context information. Hereby, WP4 – T3.3-TeC9 focuses on models for the benefits as well as challenges of deploying nomadic and moving cells. In complement, WP4 – T4.2-TeC11 aims at building context awareness based on model learning.



Similar to the handover schemes considered in MA2, the management mechanisms for nomadic and moving networks benefit from information on the interference environment. Hence, T4.1-TeC1 is also adopted in the concept for MN-M addressing MA 3. Hereby, WP4 – T4.1-TeC1-A1 aims at the identification of long-term interference couplings in the network, WP4 – T4.1-TeC1-A2 uses additional statistical information towards a more accurate assessment of the interference environment, and WP4 – T4.1-TeC1-A3 identifies potential interferers by performing signal processing to the physical layer measurements from multiple points in the network.

More information on the TeCs can be found in [MET13-D41].

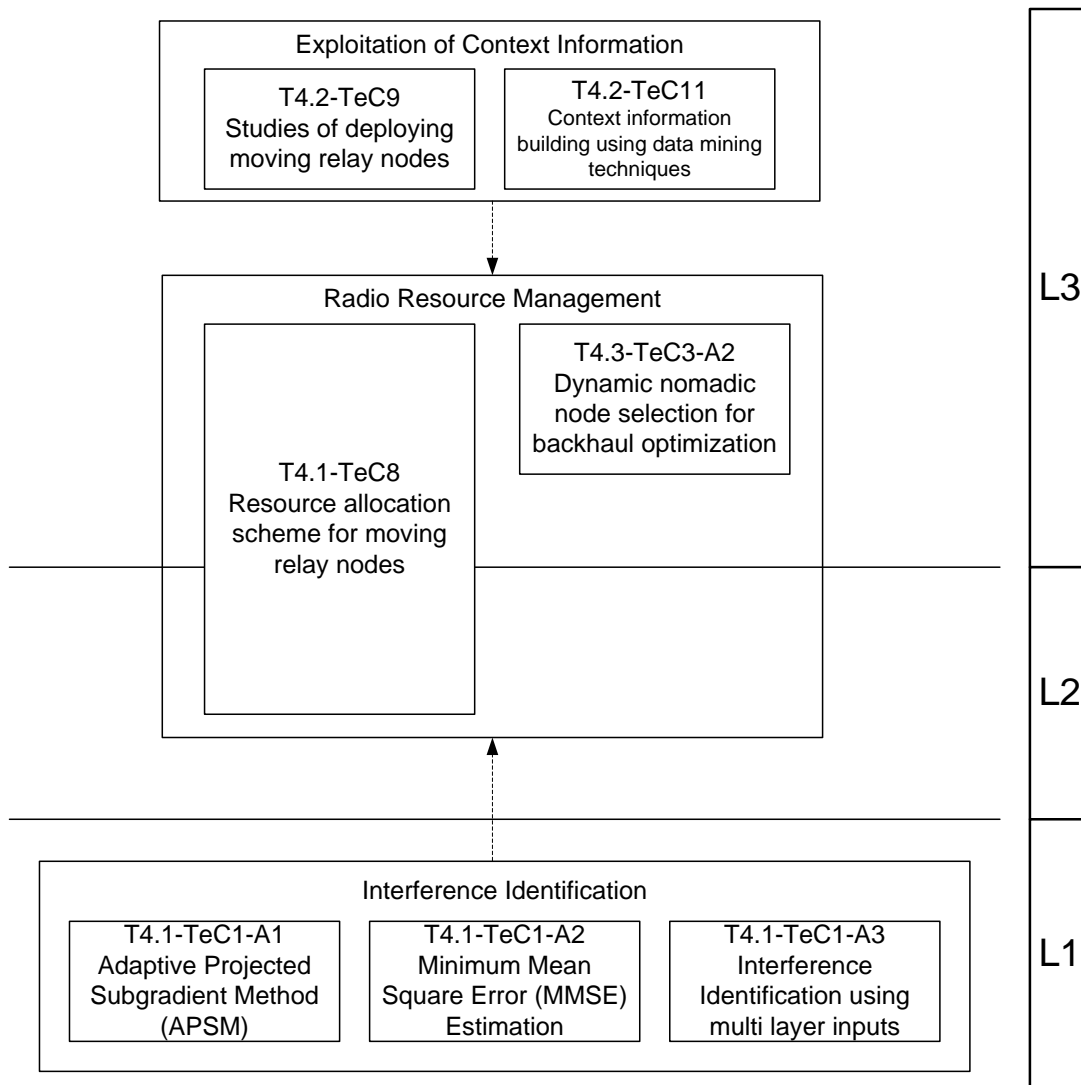

Figure 9-3: Detailed concept for MN-M covering Mobility Aspect 3.



### 9.1.3 Additional Information on the Concept of MN for Nomadic Network Nodes (MN-N)

#### 9.1.3.1 Technology components addressing MN-N

##### 9.1.3.1.1 WP2

WP2 has produced a number of Technological Components Clusters (TeCC) as a result of clustering the different TeCs being investigated in the work package [MET14-D23]. The following TeCCs have been identified as relevant for MN-N:

- *TeCC#1: Unified air interface design for UDN:* The air interface concept for dense deployment consists of the following building blocks: OFDM-based waveform, Dynamic TDD, Synchronization, Frame based access, Physical layer frequency numerology optimized for UDN, Physical frame TDD numerology optimized for UDN, Frame structure (and control signalling) optimized for UDN environment, Modulation and coding, Multi-antenna and high-gain beam-forming. Since nomadic nodes extend the concept of UDN, air interface solutions also serve the nomadic cell concept.
- *TeCC #8 – Filtered and filter-bank based multi-carrier:* the use of filtered (TeCC #8.2: UFMC a.k.a. UF-OFDM) and filter-bank (TeCC#8.1: FBMC) based multi-carrier can provide a high degree of flexibility enabling the system to be tailored to any device characteristic (e.g. high mobility, low latency) without the need for compromising between different extreme cases, even on per sub-band level. Moreover, the new waveforms allow for relaxed synchronization enabling low cost transmitters with low latency transmissions for nomadic nodes. Both TeCCs could also persist a much lower out-of-band leakage, letting the nomadic network deployment better utilize the spectrum (e.g. fragmented spectrum, spectrum sharing in different geolocations).
- *TeCC#11.2: MA using Cognitive Radio:* Multiple access using cognitive radio will support the flexible deployment of networks where the nomadic nodes can use the spectrum available locally.

##### 9.1.3.1.2 WP3

The following TeCs belonging to WP3 [MET13-D31] have been identified as relevant for MN-N:

- *T3.1-TeC#10: Multi-cell MU MIMO, decentralized transceiver design:* This considers the case where a BS serves its own set of user terminals and co-channel transmissions from each BS cause interference to the user terminals of other cells. Inter-cell interference is a key parameter in the design of distributed beamforming algorithm as it couples the sub-problems at base stations. In this work, a large dimension approximation for the optimal ICI is considered. According to this approximation an algorithm is proposed for decoupling the sub problems at base stations which results in a significant reduction in backhaul information exchange rate and processing load. It is aimed at improving throughput and reducing processing load and backhaul exchange.
- *T3.2-TeC#4: Alignment of Intra Cell Multi User and Inter Cell Interference in a MU-MIMO Cellular Network:* This TeC proposes a transmission technique along with user selection algorithms in order to increase the system spectral efficiency by dealing with multi user and inter cell interference on the basis of interference alignment in a system where the transmitter and receivers are equipped with multiple antennas. This scheme targets to improve spectral efficiency and can be adapted to nomadic networks for backhaul link improvement.
- *T3.2-TeC#7: Dynamic Clustering with multiple receive antennas in downlink CoMP systems:* This TeC develops a dynamic Clustering algorithm for downlink CoMP systems



by assuming that the UEs are equipped with multiple antennas. The TeC can be adapted to improve the wireless backhaul link for nomadic nodes.

- *T3.2-TeC#10: Joint linear downlink CoMP with enhanced signal processing at the UEs and bounds for Clustered JT*: Dynamic user centric Clustering of BSs for joint transmission CoMP could be adapted to nomadic nodes. Joint transmission CoMP to static receivers offers a large gain in data rate.
- *T3.2-TeC#12: Network-assisted interference suppressing/cancelling receivers and ultra-dense networks*: This TeC proposes utilization of network assistance (NA) for enhancing co-channel interference suppression/cancellation (IS/IC) performance of advanced interference-aware receivers. The scheme targets to provide efficient interference management solution by exploiting enhanced interference mitigation capabilities of advanced receivers. The scheme can be adapted to wireless backhaul links in order to improve the backhaul throughput of nomadic nodes.
- *T3.3-TeC#1: Coordinated multi-flow transmission for wireless backhaul*: This TeC uses the ideas of wireless network coding for two-way communication, but extends it to the case of multiple nodes with two-way communication. Specifically, one of the techniques is aimed towards flexible deployment of small cells and it demonstrates how the ideas of multi-way relaying can offer performance that is equivalent as if there is a wired backhaul. We derive the conditions under which the wireless two-way backhaul can emulate the scenario with wired backhaul, without increasing the complexity at the end terminal. The nomadic small cell created by the vehicle is an exemplary deployment for such wireless-emulated wired backhaul.
- *T3.3-TeC#10: Combining physical layer network coding and MIMO for TDD wireless systems with relaying*: This TeC considers the joint application of network coding and MIMO transmission with the aim at improving throughput or reliability and robustness in two-way relaying scenario, where the relay is mounted on top of a car. Two phase transmission reduces delay by half. The proposed solution causes additional interference to directly connected users. Therefore, interference management schemes should complement this solution especially in dense deployment.

#### 9.1.3.1.3 WP4

The following TeCs in WP4 [MET13-D41] have been identified as relevant for MN-N:

- *T4.1-TeC1-A1: Adaptive Projected Sub-gradient Method (APSM)*: This TeC is supporting resource allocation schemes by using an adaptive projection algorithm to estimate/identify long-term interference couplings between Base Stations (BSs) and users. Improved knowledge on the interference can be used to efficiently deploy nomadic networks e.g. using optimized allocation of radio resources for access and backhaul via obtained interference knowledge
- *T4.1-TeC1-A2: Minimum Mean Square Error (MMSE) Estimation*: This method uses a statistical estimation approach that combines the measurements with (i) statistical knowledge of measurement uncertainty, and (ii) prior knowledge of spatial correlation of the interference links. Improved knowledge on the interference can be used to efficiently deploy nomadic networks e.g. using optimized allocation of radio resources for access and backhaul using obtained interference knowledge.
- *T4.1-TeC1-A3: Interference Identification using multi-layer inputs*: The scheme is based on inputs from UEs, and BSs identifies potential sources of interference and allows proceeding in the proper interference handling actions. This allows for the optimum selection of radio resources for backhaul and access of the nomadic nodes



- **T4.1-TeC7-A2: X2-based distributed interference management in femto-cells (DIM-X2):** The basic idea is to group nomadic nodes into small Clusters and coordinate dynamically the resources allocation taking into account the interference received from neighbouring nomadic nodes and small cells.
- **T4.1-TeC10: Overlapping super cells for dynamic effective user scheduling across bands:** Different carriers can be allocated to different Clusters of nomadic nodes. By intertwining the connectivity, one can form these supercells in such a way that every cell edge user finds itself near the centre of a supercell with favourable situation for eICIC.
- **T4.1-TeC11: Algorithms for self-establishment of hierarchy in Clusters:** This TeC considers the establishment of hierarchy between the nomadic nodes and who-communicates-with-who determination. In case of a centralized approach, the scheme determines which nomadic cells belong to which Cluster.
- **T4.1-TeC12: Coordinated resource usage in virtual cells and nomadic relays:** The idea is to use rateless coding to reduce the need for interference coordination among nomadic cells.
- **T4.2-TeC1: Optimized distribution scheme for context information:** This feature aims at the optimization of context information distribution which can indirectly improve the KPIs such as reliability, latency and mobility. The TeC can be tuned to distribute relevant context information for nomadic nodes.
- **T4.2-TeC7: Context aware mobility handover optimization using Fuzzy Q-Learning:** This scheme considers handover optimization according to locally observed network performance in order to decrease the number of handover failures, connection dropping, ping pong handovers, etc., for UEs in nomadic nodes.
- **T4.2-TeC9: Smart mobility & resource allocation using context information:** The main target of this work is QoS improvement, for example to decrease video degradation for mobile users with the help of long-term network resource allocation based on context information. The scheme can be adapted for mobile UEs in heterogeneous networks with nomadic nodes.
- **T4.2-TeC10: Signalling for trajectory prediction:** To deduce the user's next cell using trajectory prediction mechanism the BS prepares a list of potential next cells for user transition based on predicted user trajectories. A notification about the arrival of user(s) (context message) is sent well in advance from the serving BS to the neighbouring cell next target to prepare the user transition. The scheme can also be used for the timely activation and deactivation of nomadic cells.
- **T4.3-TeC1-A1: New management interface between the operator and the service provider:** Using this TeC, service providers have access to SON based functionalities of the network and can tailor specific network setting towards better scalability and availability of the resources for C-ITSSs.
- **T4.3-TeC1-A2: New management interfaces for information exchange and action enforcement:** This TeC is enabler concept for describing the interfaces required for information exchange and action enforcement. The outcome of this TeC will be the definition of new interfaces and the enrichment of the already available ones. This scheme improves nomadic node challenges by enabling appropriate mechanisms with the management interfaces.
- **T4.3-TeC2: Clustering Toolbox:** The Clustering toolbox is an enabler for flexible network deployment. Based on the network coverage and the capacity requirements from the users, the nomadic cells may be Clustered and used for optimization of the network.



- *T4.3-TeC3: Dynamic Nomadic Node Selection for Backhaul Optimization:* This TeC enables identification of the optimum nomadic cell based on the backhaul link quality. The backhaul link quality is essential in achieving the performance enhancements promised by nomadic nodes since the channel conditions can be severe on the backhaul link due to low alleviation as user equipments. The TeC improves the end-to-end performance in nomadic node deployments in terms of backhaul link SINR, link rate, and end-to-end rate in composite Fading/Shadowing Environments while considering Co-channel Interference.
- *T4.3-TeC4: Activation and deactivation of nomadic cell:* The main idea is to model the decision of activation and deactivation as an optimization problem where the objective could be energy consumption of the whole network, user battery life or network load, etc. The constraints of the optimizing problem lie in two aspects:
  1. UEs and nomadic nodes must be connected to the network
  2. The available bandwidth at each node must be sufficient to support the minimum rate requirement of the UEs and the forward data rate of the nomadic nodes.Certain relaxation techniques are needed to efficiently solve the optimization problem since both objectives and constraints are non-convex.
- *T4.3-TeC5: Self-management enabled by central database for energy savings in the Phantom Cell Concept (PCC):* The main idea here is to equip each macro cell with a database that can aid any UE to choose the most appropriate nomadic cell only based on the UE's reported geographic location information. This macro-assisted scheme can allow the system to get rid of the energy consumption overhead caused by signalling-based state of the art schemes where nomadic cells have to turn on their RF receiving chain to be able to intercept connection requests from UEs or to periodically turn on their RF transmitting chain to send beacon signals in order to be discoverable.

#### **9.1.3.1.4 WP5**

##### **TeC Analysis**

The following TeC in WP5 have been identified as relevant for MN-N. Moreover, a preliminary analysis has been performed regarding the particularities of MN-N with regards to spectrum access and bandwidth demands (see [MET13-D51]):

- *Flexible spectrum use for MN:* This TeC increases the probability to find interference-free spectrum for nomadic nodes and wireless backhaul links.
- *Spectrum Opportunity – Detection & Assessment:* This TeC aims to manage the different spectrum bands by opening up new spectrum under specific conditions. Spectrum selection for nomadic nodes involves detection and selection of available spectrum. Spectrum demand has been classified according to traffic with interest to non-classical traffic (IoT, Smart grids, MTC, safety etc.).

##### **Spectrum Access Analysis**

- Backhaul link:
  - Exclusive access currently used by MNOs is recommended.
  - Other licensed authorization schemes could be used, as far as they provide the MNOs the targeted QoS.
- Access link:
  - Option 1: MNO assigned spectrum (FDD/TDD).
  - Option 2 (recommended): unlicensed spectrum (commonly usable by regular UEs as WiFi).



### Bandwidth and Frequency Range Aspects

- Backhaul link:
  - Frequencies preferably below 6 GHz.
  - Required bandwidth will reach up to 50 to 100 MHz.
- Access link:
  - Frequencies higher than 6 GHz could be used for hot spot small coverage areas.
  - Required bandwidth: n.a.

#### 9.1.3.2 Concept analysis of MN-N based on Mobility Aspects

In order to analyse the concept of MN-N we evaluate each one of the mobility aspects that cover the main challenges faced by this Cluster with respect to mobility. As can be seen in Table 9-2, the main challenges of MN-N are covered by mobility aspect 2 (Handover and cell reselection) and mobility aspect 3 (Management of nomadic and moving cells).

Table 9-2: Analysis of mobility aspects in MN-N.

Mobility aspect 1	<b>Link level performance in mobile channels:</b> This aspect is not relevant to MN-N as backhaul link channel of nomadic nodes is considered stationary.
Mobility aspect 2	<b>Handover and cell reselection:</b> This aspect has an important impact in MN-N, since nomadic nodes are very dynamic in the sense that they impose a certain uncertainty with regards to their availability. The inherent uncertainty requires dynamic mobility management techniques for UEs that guarantee a stable QoE.
Mobility aspect 3	<b>Management of nomadic and moving cells:</b> This is a key aspect and resembles the core components of the concept of MN-N. In order to leverage the potential system gains of nomadic networks, intelligent (de-)activation algorithms, clustering mechanisms, as well as very dynamic interference management and radio resource management schemes are required.
Mobility aspect 4	<b>Enablers for mobile D2D:</b> This aspect is not relevant to MN-N as mobile D2D is not considered as part of the concept.

### Mobility Aspect 2: Handover and Cell-Reselection

Figure 9-4 shows a detailed version of the concept for MN-N addressing mobility aspect 2. In this concept, schemes for providing context information and techniques for interference prediction serve as input to enhance UE mobility management in the context of nomadic nodes. Note that the latter resembles the core part of this concept within mobility aspect 2. UE mobility management is particularly important, since nomadic nodes are very dynamic in the sense that they may suddenly disappear and appear depending on the activation/de-activation mechanisms. The inherent uncertainty requires dynamic mobility management techniques for UEs that find themselves suddenly within the coverage area of nomadic cells. Fast handover and cell-reselection algorithms are key to cope with this uncertainty and to guarantee a stable QoE.

Seamless handover in heterogeneous networks using a fuzzy logic approach is proposed by T4.2-TeC7, which exploits a wide range of context information (e.g. network load, QoS, etc.) and is therefore useful in the context of nomadic nodes.

Several TeCs that focus on context information serve as input for T4.2-TeC7: T4.2-TeC1 and T4.2-TeC10 collect, predict, and distribute context information and lower layer measurements.

Specifically, T4.2-TeC10 enables to predict user transitions within cells and facilitates network-wide information exchange, e.g. indicating arrival of UE into a predicted cell.

Moreover, T4.1-TeC1 (A1-A3) identifies and predicts potential sources of interference by performing signal processing to standard physical layer measurements, which can be taken into account for improved UE mobility management.

More information on the TeCs can be found in [MET13-D41].

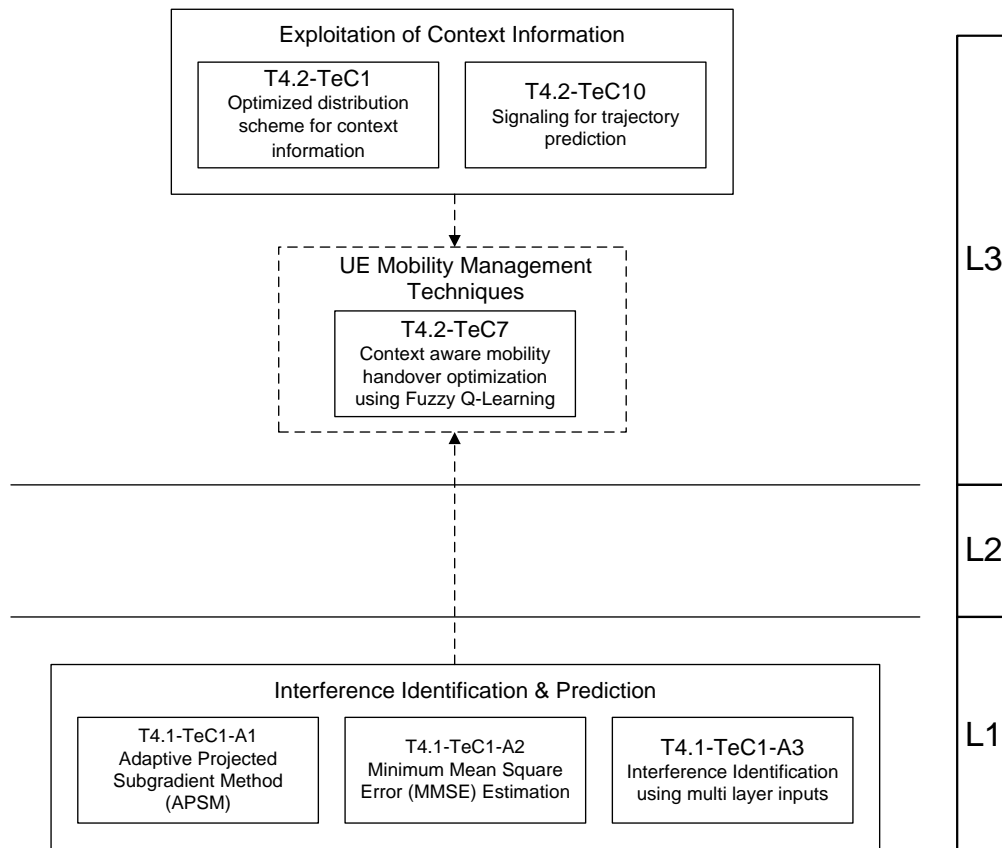

Figure 9-4: Detailed concept for MN-N covering Mobility Aspect 2.

### Mobility Aspect 3: Management of nomadic and moving cells

Figure 9-5 shows the detailed concept for MN-N focused on mobility aspect 3. The core techniques are located in the network management layer (L3) consisting of (de-)activation algorithms, Clustering mechanisms, interference management and resource allocation schemes. These schemes need to be able to cope with the very dynamic behaviour of nomadic nodes.

T4.3-TeC3-A2, T4.3-TeC4, and T4.3-TeC5 are the key technology components for the activation and deactivation of nomadic network nodes taking care of a flexible deployment based on coverage and capacity demands. T4.3-TeC3-A2 enables the identification of the optimum nomadic cells based on the backhaul link quality, thus improving the end-to-end performance in nomadic node deployments. T4.3-TeC4-A1 focuses on activation and deactivation algorithms for



---

nomadic relays in order to minimize energy consumption and to increase system capacity. Another technology component for (de-)activating small cells with the target reduce overall energy consumption of the network can be found in T4.3-TeC5, where a centralized data base at the macro cell is used as an input to coordinate nomadic nodes.

The next block of core techniques is the interference management and radio resource management techniques. These techniques need to cope with the dynamic appearance of nomadic nodes and handle their impact on interference to other cells and users in the network. The approach in T4.1-TeC7-A2 coordinates resources among nomadic cells and neighbouring cells by using different resource preference patterns. Here, coordination of the preference patterns takes place based on information exchange through the X2 interface. In contrast, T4.1-TeC12 proposes rate-less coding for nomadic nodes to avoid severe interference and to reduce the need for coordination among cells. T4.2-TeC9 focuses on smart resource allocation based on prediction of user position and application requirements in heterogeneous networks including nomadic nodes.

Another important technology component group consists of Clustering mechanisms that partition the users and cells based on certain measurements or predictions (such as user location, channel information, interference measurements) in order to improve their coordination and create favourable conditions for UEs. T4.1-TeC10 focuses on how to generically form supercell Clusters in a highly dynamical network in order to create favourable situations for eICIC. T4.1-TeC11 relies on a hierarchical approach where Clusters will be further divided into sub Clusters in order to organize dynamic networks. The Clustering algorithms are also supported by a Clustering toolbox proposed in T4.3-TeC2.

In order to leverage the full potential and system gains that can be delivered by nomadic networks, robust and high-data rate backhaul links and relaying mechanisms are required. As for backhaul enhancement, T3.1-TeC10 as well as several T3.2 schemes (TeC4, 7, 10, 12) are aimed at improving throughput and reducing processing load and backhaul exchange. The components propose interference cancellation and alignment as well as CoMP techniques.

Moreover, advanced relaying schemes such as T3.3-TeC1 and T3.3-TeC10 help to increase the performance gains offered by nomadic nodes. In particular, T3.3-TeC1 demonstrates how the ideas of multi-way relaying can offer performance gains for nomadic networks with wireless backhaul that is equivalent as if there is a wired backhaul. T3.3-TeC10 proposes the joint application of network coding and MIMO transmission with the aim at improving throughput or reliability and robustness in two-way relaying scenario for vehicular relay nodes.

Backhaul enhancement mechanisms as well as advanced relaying techniques rely on Layer 1 technology components that provide novel air-interfaces and robust waveforms. Note that in general these TeCs are the same as used for UDN and help to improve the quality of the wireless backhaul link, are essential for advanced relaying techniques and to some extent support the algorithms of the core components. In particular, these TeCs are WP2-TeCC #1/#8.1/#8.2/#11.2 (please refer to Annex Section 9.2 for more details).

Especially in nomadic networks, the core components as well as the backhaul and relaying techniques need to be very adaptive to network changes and therefore rely on user, traffic, interference and capacity prediction algorithms. This can only be achieved by exploiting additional context information and by sophisticated channel prediction. Three alternative TeCs addressing interference prediction are introduced in the HT MN concept: T4.1-TeC1-A1, T4.1-TeC1-A2 and T4.1-TeC1-A3 all aim at extracting information about the interference couplings based on incomplete network knowledge. Similar as for mobility aspect 2, T4.2-TeC1 and T4.2-





TeC10 collect, predict, and distribute context information and lower layer measurements. Specifically, T4.2-TeC10 enables to predict user transitions within cells and facilitates network-wide information exchange, e.g. indicating arrival of UE into a predicted cell.

Furthermore, new management interfaces are designed to exchange necessary control information and context information between network entities. T4.3-TeC1 defines new interfaces between operator and service provider as well as among operators. In particular, it enables the distribution of such information within the network, which will improve the accessibility of context and channel/interference information at different places in the network.

More information on the TeCs can be found in [MET14-D23; MET13-D31; MET13-D41].

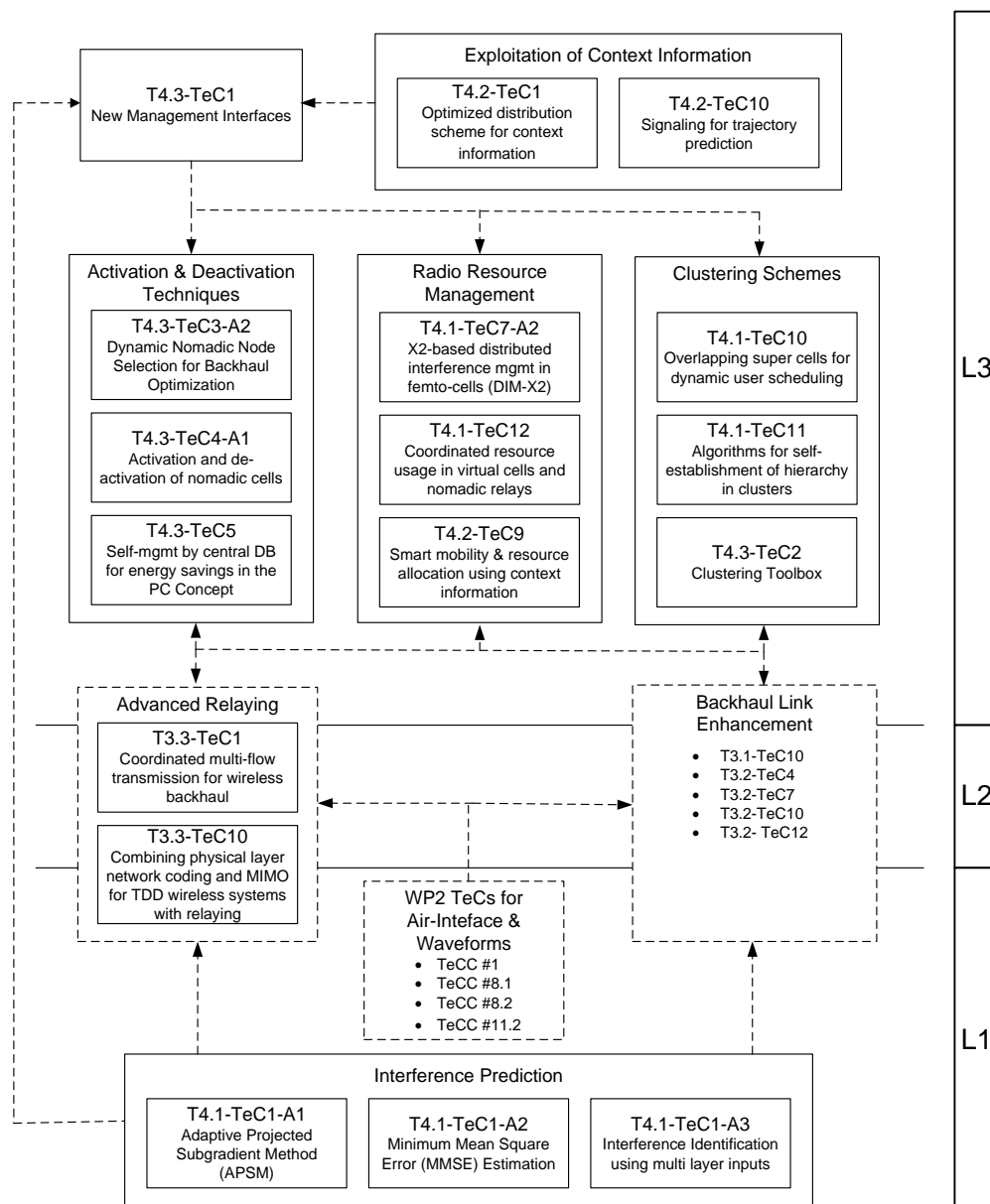



Figure 9-5: Detailed concept for MN-N covering Mobility Aspect 3.

## 9.1.4 Additional Information on the Concept of MN for V2X Communications (MN-V)

### 9.1.4.1 Technology components addressing MN-V

#### 9.1.4.1.1 WP2

WP2 has produced a number of Technological Components Clusters (TeCCs) as a result of Clustering the different TeCs investigated in the work package [MET14-D23]. The following TeCCs have been identified as relevant for MN-V:

- *TeCC #6 – Air interface of moving networks*: the framework for URC included in the TeCC is aimed at guaranteeing the availability of an ultra-reliable link and at reliably indicating the non-availability to the application. On the other hand, advanced channel estimation and predictions techniques are expected to improve the system robustness against Doppler and fast fading in highly mobile scenarios such as V2X communications. The new MAC techniques included in the TeCC are expected to enable mobile ad-hoc communications that can operate without a central coordination entity while providing QoS.
- *TeCC #8.1 – FBMC based waveform and transmitter*: FBMC could provide better localized waveforms to improve the robustness of multi-carrier transmission against the Doppler spreading effect under high mobility. Meanwhile, it could also relax the synchronization constraints to enable low cost, low latency bursty transmission.
- *TeCC #9.2 – Advanced coding and decoding*: within this TeCC, new error estimation techniques are investigated in order to reduce the latency of channel decoding algorithms. The framework on lattice codes is focused on short block lengths and, hence, constitutes a baseline for the reduction of the transmission and reception delays.
- *TeCC #10.1 – Full duplex transceiver design*: the investigation carried out in this TeCC aims at enabling full duplex transmissions for short radio links. This is well suited to the use of D2D for V2X communications, in which users should be capable to receive critical information from nearby traffic participants at any moment, even during the transmission of data packets. In particular, this TeCC could potentially contribute to reduce the latency of V2X communications in comparison to half duplex systems, since it allows designing access protocols and linking establishment protocols that use the capability to detect carrier/other signals while transmitting.
- *TeCC # 12.2 – Distributed network synchronization*: this TeCC enables the use of TDMA in ad-hoc communications by means of distributed algorithms that can achieve synchronization between communication nodes without the need of a central coordination entity.
- *TeCC #13 – Deadline-driven HARQ*: advanced HARQ techniques that take into account the maximum deadline supported by the application like the ones investigated in this TeCC can contribute to improve the reliability in V2X communications.

#### 9.1.4.1.2 WP3

The following TeCs belonging to WP3 [MET13-D31] have been identified as relevant for MN-V:

- *T3.2 – TeC #11 – Decentralized interference aware scheduling*: the work developed in this TeC could potentially improve the interference management between traffic participants (i.e. D2D devices). It still needs to be clarified if TeC #11 can cope with the inherent mobility of V2X communications.



- *T3.2 – TeC #16 – Non-coherent transmission schemes for practical inter-node coordination systems*: the use of non-coherent detection mechanisms, which perform data detection without any knowledge of the channel coefficients, can avoid the negative effects of imperfect channel knowledge in medium to high mobility scenarios, thus contributing to fulfilling the mobility requirements of TC12.

#### 9.1.4.1.3 WP4

The following TeCs in WP4 [MET13-D41] have been identified as relevant for MN-V:

- *T4.1-TeC1-A1: Adaptive Projected Sub-gradient Method (APSM)*: this TeC is supporting resource allocation schemes using an adaptive projection algorithm to estimate/identify long-term interference couplings between Base Stations (BSs) and users. The identified couplings can be utilized while accessing or allocating orthogonal resource blocks to the users. This potentially enables better resource allocation for moving terminals (e.g. vehicles).
- *T4.1-TeC1-A2: Minimum Mean Square Error (MMSE) Estimation*: this method uses a statistical estimation approach that combines measurements with (i) statistical knowledge of measurement uncertainty, and (ii) prior knowledge of spatial correlation of the interference links. This will help identify the interference in the system and lead to improved reliability. This potentially enables better resource allocation for moving terminals (e.g. vehicles).
- *T4.1-TeC1-A3: Interference Identification using multi-layer inputs*: by combining inputs from several network points, a semi-centralized mechanism for identifying potential sources of interference is being proposed. The scheme is based on inputs from UEs, and BSs for shortlisting the interferers and proceeding in the proper interference handling actions. This potentially enables better resource allocation for moving terminals (e.g. vehicles).
- *T4.1-TeC4-A3: Context-aware resource allocation scheme for enabling D2D in moving networks*: this TeC aims at efficient resource allocation in D2D-enabled cellular networks considering highly mobile terminals in the D2D underlay. Above all, it overcomes the issue of carrying out channel measurements between mobile terminals and reporting them in a timely manner such that optimal scheduling decisions can be met by a central entity (e.g. a base station). Instead, it proposes a cell partitioning approach that constantly enables favourable interference conditions for D2D and cellular transmissions and renders CSI redundant. Hence, this TeC potentially allows for lower latency in the D2D underlay (due to the skipped channel measurement step), support for highly mobile terminals (e.g. vehicles), less signalling and more efficient resource block (RB) allocation.
- *T4.2-TeC1: Optimized distribution scheme for context information*: this technical component aims to develop an efficient management and exchange mechanism for the context information.
- *T4.2-TeC2: Context awareness through prediction of next cell*: based on observed user movement patterns, e.g. daily commuters travelling in buses, trains, etc., it is possible to predict user trajectories and the next cell for transition. This TeC aims at improving handover processes and enables pro-active RRM, and thus, better resource allocation.
- *T4.2-TeC6: Handover optimization using street-specific context information*: this scheme exploits street-specific context information (e.g. route information, vehicle speed) in order to decrease handover failures of highly mobile terminals (e.g. vehicles).
- *T4.2-TeC7: Context aware mobility handover optimization using Fuzzy Q-Learning*: handover optimization according to locally observed network performance in order to



- decrease the number of handover failures, connection dropping, ping pong handovers, etc.
- *T4.2-TeC8: D2D handover schemes for mobility management:* This TeC aims at keeping the traversing D2D (and potentially V2X) users having an ongoing transmission under the control of only one access node.
  - *T4.2-TeC10: Signalling for trajectory prediction:* this TeC relies on T4.2-TeC2 for providing prediction information about the next cell for user transition and facilitates network-wide information exchange, e.g. indicating arrival of UE into the predicted cell. This context information could be exploited to make smart resource management for vehicular users and hence reduce blocking, dropping of users as well as handover failures.
  - *T4.3-TeC1-A1: New management interface between the operator and the service provider:* using this TeC, service providers have access to SON based functionalities of the network and can tailor specific network setting towards better support of V2X communications.
  - *T4.3-TeC1-A2: New management interfaces for information exchange and action enforcement:* this TeC is enabler to other TeCs for describing the interfaces required for information exchange and action enforcement. The outcome of this TeC will be the definition of new interfaces and the enrichment of the already available ones.
  - *T4.3-TeC2: Clustering toolbox:* Clustering toolbox TeC is based on a set of Clustering mechanisms for handling several networking issues; according to the special networking issue to be handled, the appropriate Clustering mechanism will be selected. In the context of MN-V, a specific clustering for V2X communications will be selected.

#### 9.1.4.1.4 WP5

##### TeC Analysis

A preliminary analysis has been performed regarding the particularities of MN-V with respect to spectrum access and bandwidth demands:

##### Spectrum Access Analysis

- The requirements of MN-V can only be satisfied by a system with **high availability and sufficient spectrum**.
- **Exclusive licensing** is the preferred option in Europe (as a life-critical service, V2X communication requires reliable spectrum access).
- Reuse of other licensed spectrum on an LSA basis is difficult due to the high mobility of vehicles and the requirement of ubiquitous spatial availability.
- If **non-exclusive spectrum access** is to be considered in this test case, contiguous spatial availability must be guaranteed in the whole of Europe.

##### Bandwidth and Frequency Range Aspects

- Spectrum for ITS [Str11]:
  - Currently, spectrum for ITS is allocated between 5850-5925 MHz in the US.
  - In Europe, there is currently 30 MHz of spectrum allocated between 5875-5905 MHz, and could be potentially expanded to 70 MHz.
  - However, in both the standards for road safety and traffic efficiency (DSRC in the US and ITS-G5 in Europe), only 10 MHz bandwidth is dedicated to the road safety application as those described in TC12.
- In scenarios with a high density of traffic participants, 10 MHz may not be sufficient to meet the reliability requirements of MN-V.



- Additional spectrum at lower frequency ranges (less than 6 GHz, or even less than 1 GHz) would be desirable. Frequencies beyond 6 GHz are not recommended since NLOS propagation is of crucial importance in some scenarios such as the case of urban intersections.

#### 9.1.4.2 Concept analysis of MN-V based on Mobility Aspects

In order to analyse the concept of MN-V we evaluate each one of the mobility aspects that cover the main challenges faced by this Cluster with respect to mobility. As can be seen in Table 9-3, the main challenges of MN-V are covered by mobility aspect 1 – link level performance in mobile channels, mobility aspect 2 – handover and cell reselection, and mobility aspect 4 – enablers for mobile D2D.

Table 9-3: Analysis of mobility aspects in MN-V.

Mobility aspect 1	<b>Link level performance in mobile channels:</b> this aspect is of great relevance for MN-V due to the very high relative velocities between communication pairs (up to 500 km/h), which results in very high Doppler shifts and very fast varying channels. In this sense, the concept has to incorporate at the physical and MAC layers mechanisms to improve the robustness against Doppler and exploit time diversity.
Mobility aspect 2	<b>Handover and cell reselection:</b> This aspect has an important impact in MN-V, especially when the V2X communication is assisted and controlled by the network infrastructure. Exploitation of context information and interference estimation techniques can assist the network when selecting the best suitable communication mode, whereas optimized handover schemes might improve the robustness of the network control, and enhance the reliability of V2X communications.
Mobility aspect 3	<b>Management of nomadic and moving cells:</b> this aspect is not relevant to MN-V as the use of nomadic and moving cells is not considered as part of the concept.
Mobility aspect 4	<b>Enablers for mobile D2D:</b> this is a key aspect in MN-V due to the central role of D2D communications. In particular, the resource allocation and device discovery has to be tailored to highly mobile terminals, whereas reliability has to be guaranteed in the D2D links.

#### Mobility Aspect 1: Link level performance in mobile channels

Figure 9-6 shows a detailed version of the concept for MN-V addressing the mobility aspect 1. The concept revolves around the air interface of moving networks (TeCC #6), which extends across both L1 and L2. This TeCC includes the concept Framework for URC as well as new MAC protocols for pure ad-hoc communication (i.e. without a central coordination entity) in case of no network coverage.

On one hand, WP2 - TeCC #8.1, WP2 - TeCC #9.2, WP2 - TeCC #10.1 and WP2 - TeCC #13 investigate at the physical layer new waveforms in addition to OFDM, coding and decoding techniques, and transceivers architectures in order to improve the robustness against Doppler effects (and thus enabling communication between vehicle participants moving at very high relative velocities). These TeCCs can potentially affect the availability of reliable links, and therefore, are connected to the framework for URC in WP2 - TeCC #6. The framework for URC will use the inputs to estimate and indicate the availability of an ultra-reliable link to upper layers

(including channel access protocols for ad-hoc mobile D2D) and to configure the transmission in order to maximize the availability of the ultra-reliable link according to the application requirements (e.g. packet size, error probability, latency, etc.). Moreover, WP3 – T3.2-TeCC #16 provides non-coherent detection mechanisms, which can potentially improve the robustness against channel estimation errors.

On the other hand, WP2 - TeCC #12.2 is a potential enabler for the ad-hoc communication MAC protocols being investigated in WP2 - TeCC #6, as it allows for network synchronization between the communication nodes in a distributed manner without the need of a centralized coordination entity.

More information on the TeCs can be found in [MET14-D23].

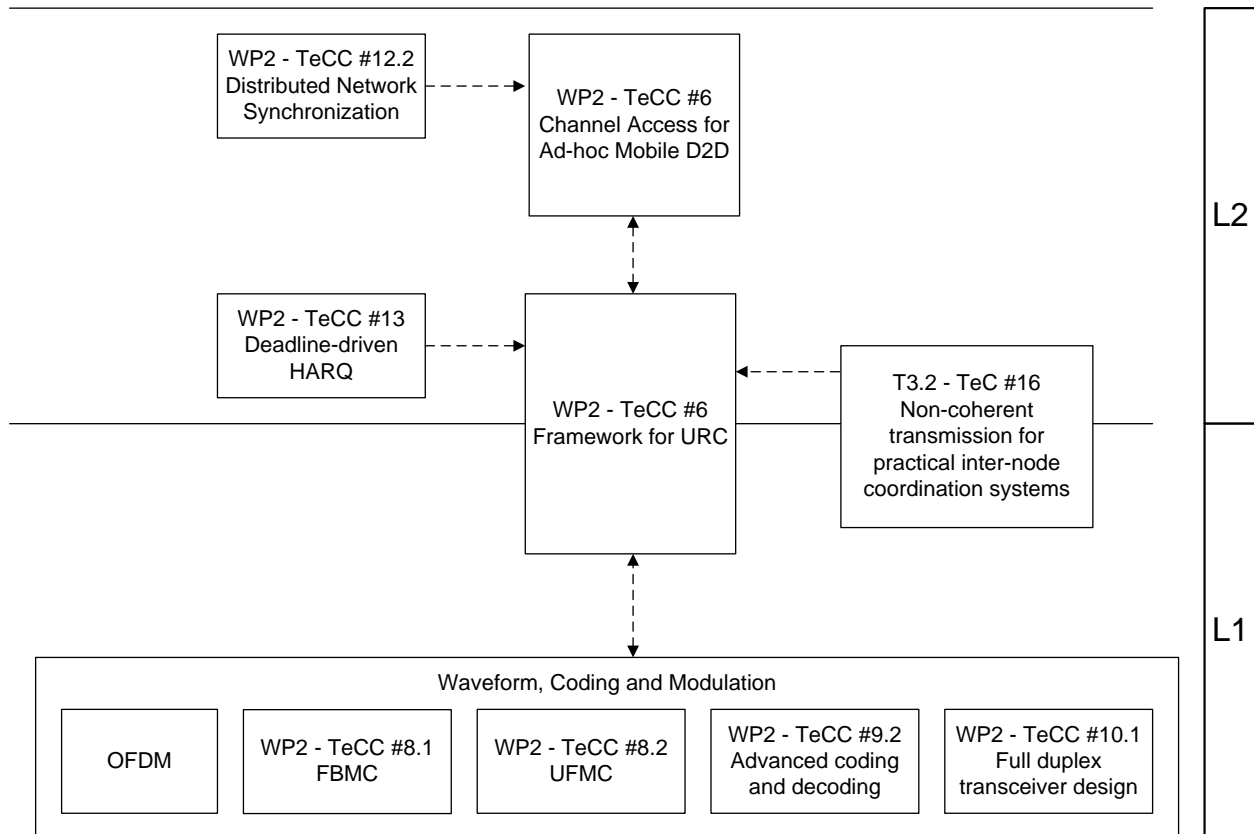

Figure 9-6: Detailed concept for MN-V covering Mobility Aspect 1.

### Mobility Aspect 2: Handover and Cell-Reselection

Figure 9-7 shows a detailed version of the concept for MN-V addressing the mobility aspect 2. The main concepts for handover optimization and cell-reselection are L3 mechanisms, whereas higher layer context information and lower layer interference identification techniques significantly improve the gains and reliability of those L3 techniques.

Among the concepts for handover optimization, T4.2-TeC2 aims at predicting where the next useful handover should take place by inspecting user movement patterns (speed, trajectory, etc.), whereas T4.2-TeC6 focuses on tuning the handover parameters for enhanced robustness. T4.2-TeC7 exploits a wide range of context information (network load, QoS, etc.) in order to optimize handover parameters in heterogeneous network using a fuzzy logic approach. Notably for TC12, T4.2-TeC8 tries to minimize network control latency for D2D by keeping the moving D2D pair under the control of the same base station.

As key enablers for those handover algorithms, T4.2-TeC1 and T4.2-TeC10 focus on how to collect, predict, and distribute the useful context information and lower layer measurements. On the other hand, T4.1-TeC1 (A1-A3) identify interferences by performing signal processing to the physical layer measurements and other information, which can be later used as input for the handover optimization techniques.

More information on the TeCs can be found in [MET13-D41].

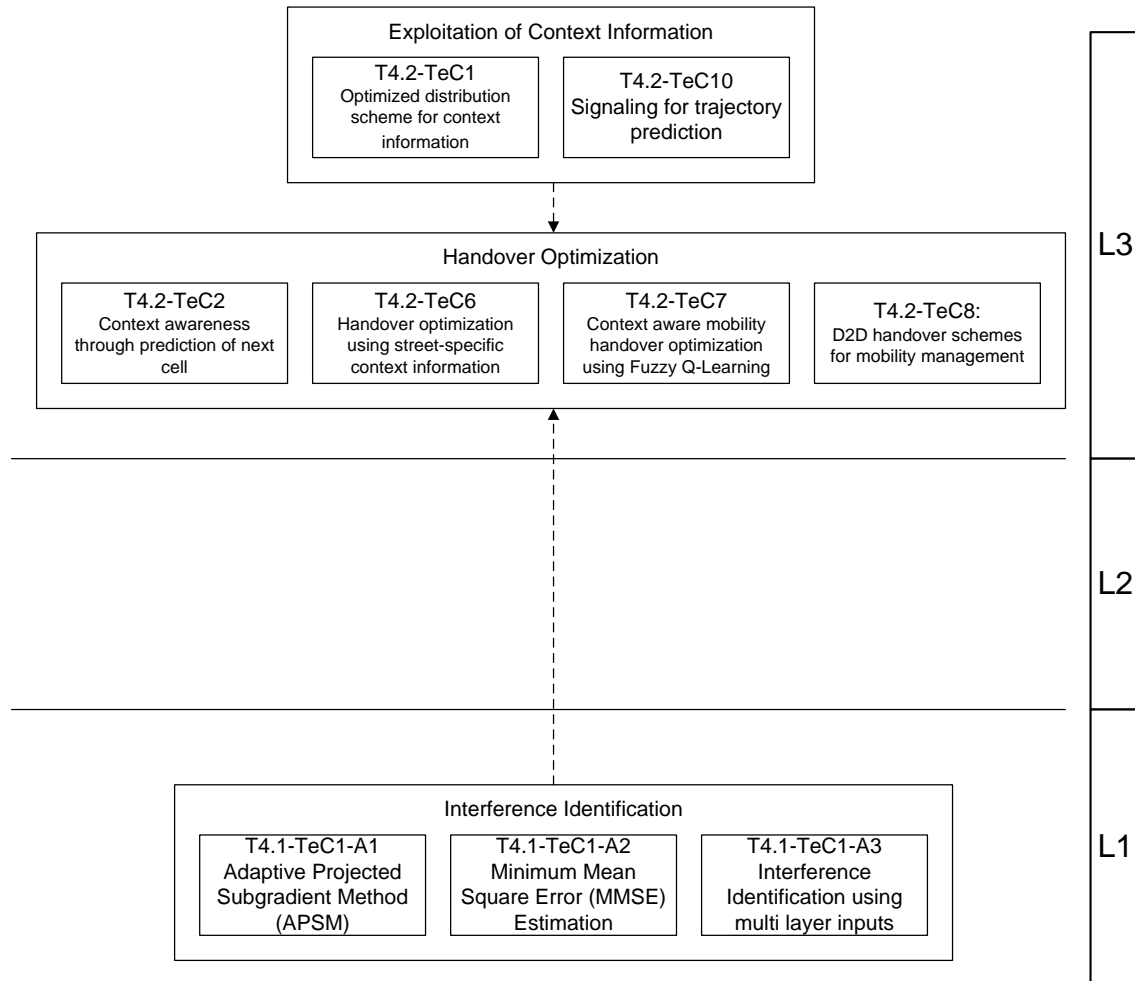

Figure 9-7: Detailed concept for MN-V covering Mobility Aspect 2.

#### Mobility Aspect 4: Enabler for Mobile D2D



Figure 9-8 shows a detailed version of the concept for MN-V addressing mobility aspect 4. The concept is built around a core of RRM schemes situated across L2 and L3. Two alternative TeCs have been identified as well suited to the requirements of TC12 in regard to MA 4. T4.1-TeC4-A3 and T4.1-TeC4-A4 address the issue of RRM for mobile D2D communication. Slightly different approaches are adopted by the two TeCs: T4.1-TeC4-A3 focuses on in-band mobile D2D communication (i.e. reuse of cellular radio resources), while T4.1-TeC4-A4 enables mobile D2D communication in a dedicated part of the spectrum. Both of these core TeCs use a type of node Clustering to some extent. Hence, the adoption of T4.3-TeC2 (toolbox allowing for the selection of an optimal Clustering algorithm depending on the objective) in the HT MN concept for TC12 can be considered helpful. At the same time, the concept incorporates from WP2 at L2 the TeCC #6 to address the channel access in the case of ad-hoc communication and the TeCC #12.2 to enable the required synchronization between traffic participants.

Another potentially beneficial synergy is identified between the core TeCs and T4.2-TeC9 which aims at more efficient use of the radio resources by exploiting the regularities that can be found in the mobility pattern of vehicles (e.g. fixed paths, expected velocity and route). The distribution of such context information could be optimized with the aid of T4.2-TeC1. Hence, this TeC could provide input to T4.2-TeC9 and T4.3-TeC2 in the HT MN concept.

Although not explicitly required by the considered core TeCs, channel state information could be used to improve their efficiency. Since complete and reliable channel estimation for the entire network based on measurements is not feasible in the context of mobile D2D communication, prediction or estimation of the interference environment could prove to be a better approach. Three alternative TeCs addressing this problem are introduced in the HT MN concept: T4.1-TeC1-A1, T4.1-TeC1-A2 and T4.1-TeC1-A3 all aim at extracting information about the interference couplings based on incomplete network knowledge.

More information on the TeCs can be found in [MET14-D23; MET13-D41].



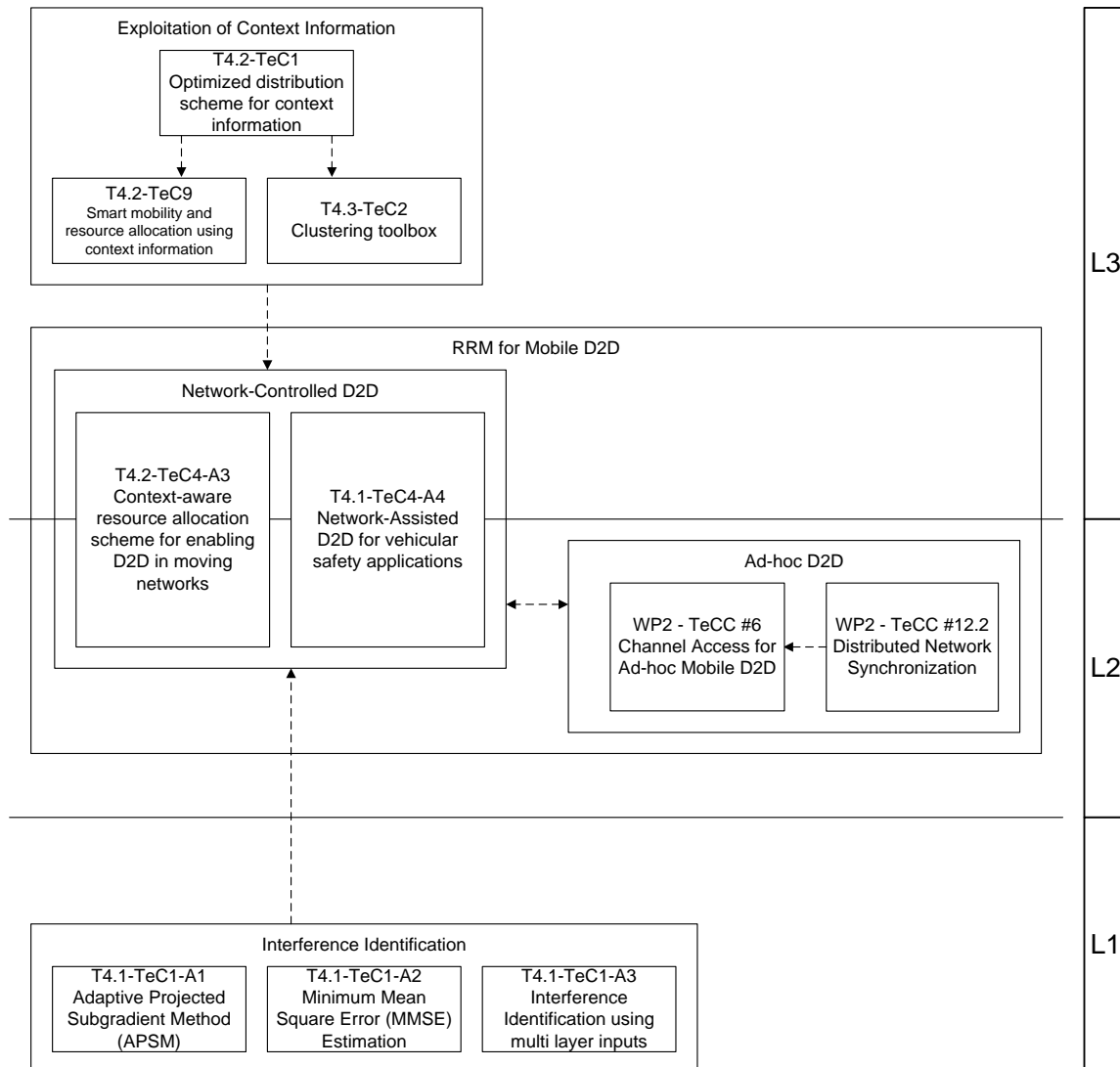

Figure 9-8: Detailed concept for MN-V covering Mobility Aspect 4.

## 9.2 HT Ultra Dense Networks

### 9.2.1 UDN Concept – core part

In the following sections components relevant for core part of the concept proposal are introduced by each WP. At the beginning it is worth to bring back the main assumption introduced in Section 3.2.4.2. The keystone components are preselected in WP2 while WP3 and WP4 TeCs where verified accordingly to their applicability. Also other alternative TeCs potentially supporting UDN concept' are listed.

#### 9.2.1.1 WP2 - new air interface design

The new air interface design principles were introduced in Section 3.2.4.2 together with main improved KPIs. This section introduces more details about TeCs jointly with their enabling properties [MET14-D23]:



- *TeCC#1: Unified air interface design for UDN* provides optimised solutions for short distance communication up to 200 m. The Cluster investigates new design for frame structure, applicability of dynamic TDD, and harmonized OFDM / PHY layer numerology from low to high frequencies on mmW bands. The solution gives support for robust and fast control plane, fast network synchronization, short physical layer latency (data RTT latency), flexible data direction switching (for wireless backhauling, network controlled small cells), PHY layer enablers for interference handling by cross-link interference mitigation capabilities and support of OFDM-based MIMO solutions.
- *TeCC#8.2: Universal filtered multi-carrier (UFMC)* enables the network to support spectrum usage more flexibly and improves spectral efficiency (reduced overhead, e.g. less guards, less ranging overhead). Modulation improves support of high speed users, improved user separation, less tight user synchronization required than with OFDM. UFMC offers higher spectral efficiency than OFDM (~10% with LTE settings) incl. overhead reduction for synchronization data. UFMC enables very low latencies through very short filter lengths. Even multiple concurrent TTI definitions are possible. Improvement compared to OFDM through reduced synchronization overhead (less messaging and earlier switch to sleep mode possible). Oscillator may be less precise than with OFDM.
- *TeCC#12.3: MAC for UDN and mmW* - High gain beamforming is an important component in UDN at mmW bands which is also challenging for the MAC design due to occurring hidden node problem with very narrow beams. A hybrid MAC approach is considered to leverage the advantages and avoid the disadvantages of the contention based and the scheduled based protocols for UDN at mmW bands.
- *TeCC#4: Interface management & advanced signalling concepts*; Software Configurable Air Interface that is able to adapt to given traffic type and UE condition (including UDN), is studied / developed. Work is focused on two complementary components: TeC4.1: multi-RAT PHY layer design / multi-band processing allows selecting available RAT with optimum energy efficiency based on Green link budget CQI metric. TeC4.2: software configurable air interface allows for dynamic configuration of the air interface according to deployment and propagation conditions. It enables better integration of the new air interface numerology for UDN as one of the operation modes.

#### **9.2.1.1.1 Alternative TeCs**

- *TeCC#8.1: Filter-bank Multi-carrier modulation (FBMC) based waveform & TRX - FBMC modulation schemes for improving spectral efficiency and throughput.* Work under this area (TeC8.1.1: Reconfigurable Transceiver, TeC8.1.2: PHY layer TRX design and implementation, TeC8.1.3: PHY layer waveform design) could enable the network to support more flexible spectrum usage and improve spectral efficiency including MIMO / MU-MIMO support. It provides better mobility support for high speed terminals. FBMC is partly suited to the proposed UDN design, as FBMC is also able to improve user separation (i.e. enables the system to support less tight user synchronization). The aspect of FBMC making it less suited for the UDN design is the need for longer filter responses, which somewhat counteracts the target of low latencies and short TTIs.
- *TeCC#7: Faster than Nyquist (FTN).* Transmit signals at a rate that is faster than the Nyquist rate to improve the throughput or spectral efficiency. It works especially at high SNR which is expected in UDN. If the channel condition permits, the FTN mode will be



activated to boost the user throughput. Low velocity is preferred (possibly also less frequency-selective fading, e.g. indoor or strong LOS), relaxed latency and cost constraint. Work is focused on receiver design (including ML detection and interference cancelation) and boundaries of FTN w.r.t. mobility and delay spread and adaptive modulation and coding schemes. FTN is applicable to any of the proposed waveform designs and increases the system throughput if excellent channel conditions are present. With FTN significant complexity increase for reception is expected, and thus it is more applicable to UL transmissions.

- *TeCC#9.1: Constrained envelope coded modulation* – new applicability of MMC enabler for power efficient modulation to power limitation for mmW bands in high data rates scenarios. It provides answers on how to achieve stable coverage with mmW.
- *TeCC#10.1: Full duplex TRX design* for improving spectral efficiency and throughput. It could be utilized for fast concurrent access link and backhauling. TRX design for UDN context. Full duplex could enable the network to support more flexible spectrum usage and improve spectral efficiency; In addition it could provide better mobility support for high speed terminals.
- *TeCC#11.1: Non- and quasi-orthogonal multiple access* allowing spectrum overload techniques allowing using the same spectral resources for different users by CDMA-like access (TeC2 and TeC3) via superposition in the power domain (TeC1). Enables spectrum overloading with smooth performance degradation. Work is performed by TeC11.1.1: NOMA use superposition in power domain, TeC11.1.3: Advanced coded multi carrier access (SCMA) use quasi-orthogonal sparse codes (many zeros in sequence). Spectral resources are shared and can be accessed by different users simultaneously. Overloading is possible (more accesses than orthogonal resources). Implying that achievable user data rate may be significantly increased. Unscheduled access possible (TeC2 and TeC3), allows for reduced latency.
- *TeCC#13 Deadline-driven Hybrid Automatic Repeat Request* - asymmetric modulation for multi-level ACK/NACK. It is an extension of backtrack retransmission (BRQ) concept that operates on the fixed coding rate and packet length and operating only on the number of parity bits. Instead of sending feedback after each packet, the feedback bits from multiple slots are assembled and, using vector quantization, provide information relevant to a number of packets transmitted in the past. This challenges the conventional HARQ wisdom and brings improved performance, at the price of an increased delay.

For the presented components applicability to UDN in the context of METIS goals is seen as limited. For TeCC#8.1 FBMC, potentially combined with TeCC#7 Faster than Nyquist it is expected to achieve performance improvement similar to UFMC proposal in poor and moderate channel conditions while in excellent channel conditions FTN indeed can offer major performance improvement. However in both cases significant complexity increase is expected. Also for both TeCs it is expected that most of the computational efforts will be done by the receiver while for UDN nodes and user equipments the baseband processing power could be equally low. Similar complexity issues in this case related with interference cancelation will take place for TeCC10.1 full duplex TRX and TeC#11.1 related with non- and quasi orthogonal multiple access techniques. For FBMC/FTN and Full Duplex/NOMA TRX schemes it must be shown that complexity increase will not be an issue also together with e.g. MIMO schemes. TeCC#13 Deadline-driven Hybrid Automatic Repeat Request is providing improved link efficiency with the cost of increased latency while UDN should provide solutions for high data

rates where low latency plays critical role due to the transmission protocol RTT requirements. TeCC#9.1: Constrained envelope coded modulation potentially could contribute to mmW PHY layer design for reliability issues in case of poor channel condition. However other techniques related with MAC and RRM design can result in equally efficient solution.

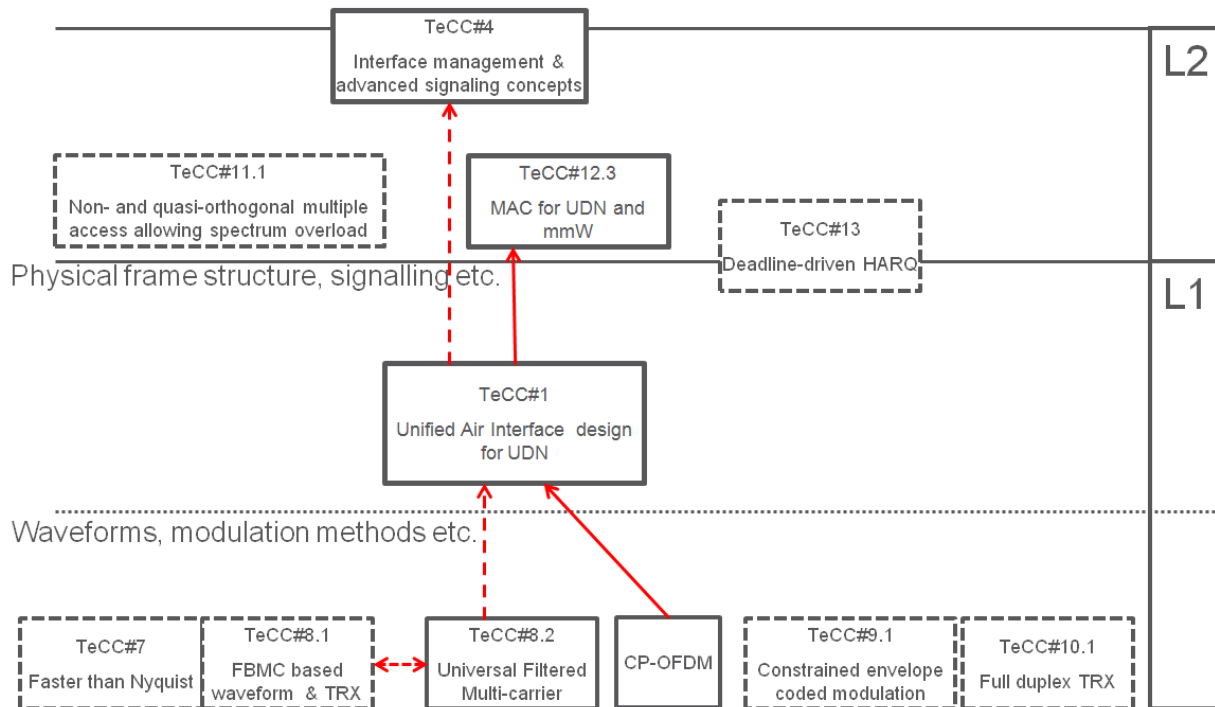

Figure 9-9: WP2/UDN relevant TeCs mapped on protocol layer 1 and 2 with an indication of ongoing (solid arrow) and potential (dashed arrow) collaboration.

### 9.2.1.2 WP3 Clustering and self-backhauling techniques

Wireless backhaul for UDN should be self-configurable, adaptive to changes in network topology and network load. High link capacity is critical requirement to aggregate traffic and low physical frame latency is an enabler for the multihop connection between nodes.

In WP3 the following TeCs [MET14-D32] are investigated for multihop and network coding for UDN self-backhauling:

- *T3.2 TeC.14 - Joint dynamic clustering and coordinated scheduling for relaying with Physical Layer Network Coding* lower cost and higher flexibility of relay nodes compared to fixed access points with wired backhaul. The goal is to match the spectral efficiency achievable with wired backhaul using relay nodes.
- *T3.3-TeC1: Coordinated multi-flow transmission for wireless backhaul.* Addresses high density of networks/access points with wireless backhaul links. Cost, flexibility and spectral efficiency of wireless backhaul deployment comparable to wired backhaul due to the extensive use of network coding for relaying node.



- *T3.3-TeC10: Combining Physical Layer Network Coding and MIMO for TDD* wireless systems with relaying the two-phase two-way relaying scheme is investigated. The main focus in this contribution is put on the second phase where two different schemes are compared: network coding and MU-MIMO
- *T3.3-TeC3: Virtual Full-Duplex Buffer-Aided Relaying* almost double spectral efficiency can be achieved in a virtual full-duplex relaying network exploiting buffer and multiple antennas, compared to state-of-the-art half-duplex relaying. For network densification, reduced transmit power and cell coverage are considered in each cluster, a minimal network used in the TeC. Enable full recovery for a loss of multiplexing gain in the half-duplex relaying- increase spectral efficiency. Interference cancelation requires moderate processing complexity due to the replacement of interfering signal reception with by buffer extension. Applicable to multihop high interference scenarios.
- *T3.3-TeC2: Interference Aware Routing and Resource Allocation in an mmW UDN* - The Interference aware routing over Dense Access points, providing self-backhauling, is enabling densification to levels that may not be practical for wired backhaul. This will support the most traffic demanding scenarios anticipated for 5G. It is also an enabler for mmW where propagation conditions may otherwise cause isolation if not routed over multiple hops through access nodes that may also serve device access. For ease of deployment in diverse environments, routing schemes and schemes for resource allocation between access and backhaul need to a large extent be generic to the topology of the UDN access point mesh

The following component provides also novel solutions for clustering and coordinated transmission techniques that might be reused in UDN core part of the concept.

- *T3.2-TeC15: Adaptive and energy efficient dense small cells coordination.* The work proposes the introduction of a beacon signal that can be used to facilitate the usage of CoMP schemes in presence of several dense small cells. If base stations are equipped with fast on/off switching mechanism, coordination between available base stations can be designed in such a way that traffic requests are met with a limited number of BS, that cooperates to serve the user while at the same time reducing overall power consumption

#### **9.2.1.2.1 Alternative TeCs for wireless backhauling**

This section introduced alternative TeCs that could be apply if different design choices will be made in WP2 [MET14-D23] for UDN concept like relaying and network coding combined with non-orthogonal access schemes NOMA :

- *T3.3-TeC4: Distributed Coding for the Multiple Access Multiple Relay Channel.* To reach high spectrum efficiency, non-orthogonal access techniques combined with wireless network coding are considered in a cooperative communication setting.
- *T3.3-TeC5: Bi-directional relaying with non-orthogonal multiple access.* IDMA as a non-orthogonal channel access scheme in combination with network coding allows for a very flexible design of MAC and broadcast phase in order to support a dense node deployment and flexible rate requirements

#### **9.2.1.2.2 Complementary WP3 TeCs based on CoMP schemes**

The WP3 is performing studies in Task 3.2 on further enhancements and enablers for real-life CoMP implementations [MET14-D32]. Currently investigated scenarios consider heterogeneous deployments with different densities of small cells optimising performance and number of nodes.



Investigated enablers as they can provide significant relaxation on backhaul requirements, should be reconsidered and their applicability to core part of UDN concept should be verified in later stage of the project. TeCs with the largest potential for contributions have been introduced below:

- *T3.2-TeC3: Distributed Precoding in multicell multiantenna systems with data sharing* is significantly relaxing backhaul requirements for multicell MU-MIMO precoding.
- *T3.2-TeC7: Dynamic clustering with multiple receive antennas in downlink CoMP systems* considers simpler clustering techniques thanks to enhanced cancellation capabilities of multi-antenna UEs
- *T3.2-TeC10: Joint linear downlink CoMP with enhanced signal processing at the UEs and bounds for clustered JT* is reducing the feedback requirements thanks to channel prediction algorithm in the UE receiver
- *T3.2-TeC12: Network-assisted interference suppressing/cancelling receivers and ultra-dense networks* is improving performance thanks to interference capabilities of UEs assisted by the network that provides interference information or transmission points coordination.

### **9.2.1.3 WP4 Interference management, clustering & mobility.**

In this section the WP4 TeCs [MET13-D41] are split accordingly to the core part building blocks for 1) clustering algorithms and initial network setup; traffic driven dynamic nodes (de-)activation 2) short term radio resource and interference management, 3) long term radio resource and interference management.; 4) Interference identification techniques; 5) user mobility in ultra-dense deployments. In 1) TeCs responsible for creation of collaborative clusters and dynamic nodes activation are shown. Also it is worth to mention that the difference between 2) and 3) is weak and depends only on the frequency of information exchange and over all control signalling latency. In both 2) and 3) WP4 is trying to provide guidance on the necessary level of network centralization in 5G systems not only in UDN specific proposal. WP4 is also working on the schemes that will allow decrease of network centralization level. In 4) complementary components related with interference identification are introduced for long term RRM. In 5) single component not related with context awareness is presented.

- 1) Dynamic nodes (de-) activation and clustering mechanism plays important role for UDN deployments. Main challenges are related with less restricted planning during network deployments and high fluctuations in a traffic demand over the day and reliability of the network in case of network damaged. Following TeCs contributes to this aspect.
  - *T4.3-TeC2: Clustering toolbox* - depending on the problem and the objective, the appropriate clustering mechanism from the toolbox will be used to group the nodes. The toolbox will incorporate clustering mechanisms from several research fields (i.e. data mining, sensor – ad hoc networks, graph theory, etc.) Positioning (absolute or relative) information shall be available. Information exchange among nodes to be clustered.
  - *T4.1-TeC10: Overlapping super cells for dynamic effective user scheduling across bands* Different carriers can be allocated to different clusters. By intertwining the connectivity, one can form these supercells in such a way that every cell edge user finds itself near the centre of a supercell with favourable situation for eICIC. With the possible drawback for dynamic TDD performance in conjunction with eICIC.
  - *T4.3-TeC4 - A1: Activation and deactivation of nomadic cells* The main idea is to model the decision of activation and deactivation as an optimization problem where the objective could be energy consumption of the whole network, user battery life or network



- load, etc. The constraints of the optimizing problem lie in two aspects: 1) UEs and RNs must be connected to the network and 2) The available bandwidth at each node must be sufficient to support the minimum rate requirement of the UEs and the forward data rate of the RNs. Certain relaxation techniques are needed to efficiently solve the optimization problem since both objectives and constraints are non-convex.
- *T4.3-TeC4 - A2: Activation and de-activation of APs* Based on the capacity requirements and the coverage needs, the network proceeds in activation and de-activation of APs.
- 2) The following mechanisms investigate different approaches for centralized and decentralised schemes for radio resource allocations & interference management. The interaction time with the network can vary from few to hundred TTIs. Mechanism will benefit from new AI design due to the fast network synchronization, clean HARQ structure with reduced latency and cross-link interference mitigation capabilities.
- *T4.1-TeC6-A1: Coordinated fast uplink downlink resource allocation in UDN* Resource allocation to mitigate inter-cell cross-link interference between uplink and downlink generated by dynamic TDD.
  - *T4.1-TeC7-A4: Decentralized scheme for UDN.* RRM for centralized/decentralized/distributed interference mitigation studies to compare the performance with fully centralized and distributed schemes.
  - *T4.1-TeC6-A3: CSI-based coordination scheme for Macro or small cells with non-coherent JT CoMP* Use non-coherent JT CoMP with CSI at the Receiver. A subcarrier set consisting of blocks of subcarriers is allocated to each UE. The block is repeated  $n$  times equidistantly in frequency depending on the available bandwidth to exploit the frequency diversity. The component works on the short time coordination and is important for reliable connectivity in UDN and could be considered for the new system design, however as such it is not UDN specific and introduce functionalities towards HT URC long term reliability concept (URC-L).
- 3) Long term decentralized and hybrid schemes for radio resource allocation and interference management can benefit from reduced control signal latency that might accelerate the mechanism.
- *T4.1-TeC7-A1: Time-sharing interference mitigation using resource auctioning and regret-matching learning.* Tries to mitigate interference using the correlated Equilibrium approach.
  - *T4.1-TeC7-A2: X2-based distributed interference management in femto-cells (DIM-X2)* Group Femto-cells into small clusters and coordinate dynamically the resource allocation taking into account the interference received from neighbouring femto-cells.
- 4) Interference identification techniques were identified as relevant for long term RRM, but aren't directly RRM scheme. Proposed mechanisms could be used to identify long term interference coupling which can be potentially beneficial for long term RRM. Mechanism require knowledge of channel gains, RSRP measurements to estimate the channel gains locally, position/location (relative or absolute) of each device known to both (BS and device itself). The following approaches are an enabler for techniques increasing spectral efficiency:
- *T4.1-TeC1-A1: Adaptive Projected Sub-gradient Method (APSM)* for interference identification. Estimates long-term interference coupling for better allocation of orthogonal resource blocks;



- *T4.1-TeC1-A2: Adaptive Minimum Mean Square Error (MMSE) Estimation for Interference identification uses a statistical estimation approach that combines the measurements with statistical information of uncertainty and prior knowledge of spatial correlation;*
- *T4.1-TeC1-A3: Interference Identification using multi-layer inputs*

5) Most of the mobility aspects for UDN in WP4 are related with use of context awareness information where this information can be founded in Annex Section 9.2.3.3. The following TeC is enhancing user mobility especially for mmW by taking the advantages only from multi band operation on low frequencies to initiate mmW connectivity.

*T4.1-TeC13: Small cell mobility enhancements in multi-carrier and mmW small cell networks. Novel small cell search mechanisms for multi-carrier (including mmW) for small cell deployments might be considered as complementary solution to WP2TeCC#12.3.*

#### **9.2.1.4 WP5 Spectrum aspects**

WP5 investigates spectrum sharing TeCs that some of them could work as a part of standalone system e.g. Algorithms enabling sharing in unlicensed bands could be embedded in proposed in UDN concept.

### **9.2.2 Extended UDN Concept – Context Awareness**

#### **9.2.2.1 WP4**

Context Awareness (CA) is a relatively novel approach of using contextual information for support network decision on connection management, handover procedures and network management [MET13-D41]. CA is valuable enabler that fits well in to the URC long term reliability: it enables traffic steering in case of predicted coverage holes and reliable handovers. Handover related system performance is improved.

- *T4.2-TeC2: Context awareness through prediction of next cell* Based on trajectory of daily commuters (travelling in buses, trains) it is possible to predict the next cell for transition and improve handover procedure.
- *T4.2-TeC10: Signalling for trajectory prediction* to deduce the user's next cell using trajectory prediction mechanism the BS prepares a list of potential next cells for user transition based on predicted user trajectories.
- *T4.2-TeC6: Handover optimization using street-specific context information* - consider context-aware handover parameter settings, which can be applied for example in a street-specific fashion. It requires following information: radio propagation map; antenna-tilt and bore sight; handover statistics are available at BS side, topology of street where vehicles are driving; speed and orientation are available at UE side
- *T4.2-TeC7: Context aware mobility handover optimization using Fuzzy Q-Learning.* Self-adaptation of handover parameters according to locally observed network performance
- *T4.2-TeC9: Smart mobility and resource allocation using context information* like prediction of user position and application requirements. Allow prebuffering of user data before entering coverage holes to meet QoS requirements.





## 9.2.3 Extended UDN Concept – RAT selection, spectrum sharing aspects and network interfaces

### 9.2.3.1 WP2

WP2 investigates [MET14-D23] TeCC#4 (described in Annex Section 9.2.2.2) which is design for RAT selection based on the PHY layer information in this aspect is extended to the multiple different RAT technologies.

### 9.2.3.2 WP4

WP4 investigates [MET13-D41] 1) multiple TeCs for RAT selection including device driven and with use of context awareness information 2) novel network interfaces for support e.g. context information exchange, enable better integration of the UDN network in MNO infrastructure or allow information exchange between spectrum sharing entities.

1) RAT selection oriented TeCs:

- *T4.2-TeC5-A2: User anchored multi-RAT self-managed load* - Cell load information is broadcasted to UE for vertical handover / RAT selection decisions. UE sends neighbour cell load indications to serving BS as part of the measurement reports. UE can perform cell selection/reselection taking cell load into account, and BS can incorporate neighbour cell load indications into vertical handover /RAT selection decisions.
- *T4.2-TeC14: Context-aware smart devices and RATs/layers mapping* Use of different types of context information to optimize the resource mapping among different radio access technologies (RATs).
- *T4.2- TeC4-A1: UE autonomous service connectivity management* .The main idea is to utilize alternate connectivity options in heterogeneous networks, not only the instantaneous knowledge of a wireless connectivity and the current QoS but also the longer term information can be utilized by the middleware in the device. Mechanism to facilitate the layer selection taking into account the knowledge of wireless connectivity and additional context information
- *T4.2-TeC5-A1: User Oriented Context-aware vertical handover RAT selection mechanism* using inputs from several RATs so as to conclude to the optimum technology per service. Use of a fuzzy logic decision making engine for the RAT selection process. Could be combined with WP2:TeCC#4.

2) Novel network interfaces should support information exchange beyond currently considered in the 3GPP standard for TeCs listed in 1) and WP5 sections.

- *T4.3-TeC1-A1: New management interface between the operator and the service provider* Interfaces between service providers and operators for both long term RRM and context provision: Case 1: Service provider gets direct access to the SON-based functionalities (for monitoring and control) of the RAN in order to optimize the parts of the network affecting its customers. Case 2: Context-based optimization processes obtains all necessary information from the RAN and interacts with SON mechanisms. Also, MNO has full access to this processing and is able to tune it. In this case, SPs can get access to the context-based processing via the new class of interfaces referred to as Interface – Context Information. Enables the dynamic network configuration based on inputs from the service providers. This enables higher mobile data volumes and reduction of the E2E latency.



- *T4.3-TeC1-A3: Interfaces for context exchange in RANs and among operators* Next cell prediction for: mobility support, resource management efficiency, energy efficiency, and user QoE. The next cells are predicted based on user direction (angle). Distance is also taken into consideration.
- *T4.3- TeC3 - A1: Integrated backhaul management.* Dynamic traffic allocation control based on DWDM-Centric transport solution, aiming to handle traffic variations in time and between different areas. The solution considers aspects related access/aggregation networks architecture and fixed backhaul/fronthaul technologies for flexible deployments, in order to support traffic variations, scalability and E2E latency requirements. Enabler for adaptive networks and integrated network management.

### 9.2.3.3 WP5

WP5 [MET13-D51] investigates multiple components contributing to the extended UDN concept. Three main areas are focused on:

- 1) **Coordinated spectrum sharing**, between mobile networks belonging to different operators. Group of components is trying to answer very similar question to WP4 about coordination level needed for sufficient radio resource reuse by different networks at the same time. WP5 is also working on the techniques enabling more relaxed requirements for coordination. TeCs belonging to this group are:
  - Algorithms enabling sharing in unlicensed bands
  - Coordinated multi-carrier waveform based sharing technique
  - Co-ordination protocol for interaction between operators supporting the use of limited spectrum pool and mutual renting
  - Inter-UDN coordinated spectrum sharing
  - Reinforcement Learning scheme for adaptive spectrum sharing
- 2) **Spectrum management** concept brings ideas for functional enablers for efficient spectrum management (spectrum sharing) including UDN networks.
  - Spectrum opportunity detection and assessment
  - Role Model for Spectrum Management
  - Ontologies as tool for spectrum decision making
- 3) **Research Studies (on interference modelling)** contribute as potential elements of algorithms for first two groups of components.
  - Inter-operator separation rule for non-cooperative spectrum sharing
  - Modelling aggregate interference distribution in environments with non-uniform user density and terrain-based propagation
  - Coexistence-aware resource allocation for extremely close nodes
  - Modelling aggregate interference from in-car BS to indoor femto-cells
  - Generic models and Tools for coexistence evaluation



### 9.2.4 Extended UDN Concept – Wireless Backhauling for UDN from macro site

As described in Section 3.2.4.3 flexible deployments of UDN based on the local capacity requirement instead of fixed backhaul availability is a great enabler for UDN from techno-economic aspects. In extended UDN concept proposal, UDN nodes are effectively giving relaying functionality while macro BS's are providing good backhaul quality link with enough capacity to aggregate UDN local traffic. For this purpose high spectral efficiency and reliability is expected from serving radio link.

#### 9.2.4.1 WP2

Currently in METIS project there is no clear preference on the modulation for future system that could be deployed for macro cells. The new waveform TeCs [MET14-D32] listed in Annex Section 9.2.1.1 could be considered for this purpose, however this aspect require considerations beyond HT UDN.

#### 9.2.4.2 WP3

The massive MIMO on IMT/IMT-A bands and on mmW, CoMP and interference alignment techniques might jointly contribute to the performance capacity increase for wireless backhauling for UDN networks. The applicability of the following TeCs [MET14-D32] requires additional analysis. Relevant massive MIMO proposals consider outdoor stationary and high mobility environments. CoMP and massive MIMO can be coupled in an interference management framework that delivers high spectral efficiency and coverage. NAIC (Network Assisted IC) like solutions can further improve the link quality and allow for joint TX/RX coordination strategies.

Specific CoMP strategies can be designed to relax the requirements for CoMP operations on the backhauling.

Two groups of potential solutions have been identified:

- 1) Solutions considered as evolution in PHY provide mostly outdoor support. The latency requirements are expected to be met.
  - *T3.1-TeC2: Low rate and simple coordination techniques for pilots.*
  - *T3.1-TeC5: Model based channel prediction – low feedback rates.*
  - *T3.1-TeC10: Multi-cell MU MIMO, decentralized transceiver design.*
  - *T3.1-TeC11: HetNet Multi-cell, MU Massive-MIMO massive SDMA.*
  - *T3.2-TeC4: Alignment of Intra Cell Multi User and Inter Cell Interference in a MU-MIMO Cellular Network.*
  - *T3.2-TeC7: Dynamic clustering with multiple receive antennas in downlink CoMP systems.*
  - *T3.2-TeC9: Coordination scheme for medium range interference with message splitting to facilitate efficient SIC.*
  - *T3.2-TeC12: Network-assisted interference suppressing/cancelling receivers and ultra-dense networks.*
  - *T3.2-TeC13: Extension of IMF-A interference mitigation framework to small cell scenarios and Massive-MIMO.*
- 2) Additionally WP3 investigates components based on the PHY on mmW which needs further refinement w.r.t. AI considerations for the core part of the concept.



- *T3.1-TeC1-b: DFT based Spatial Multiplexing and Maximum Ratio Transmission (DFT-SM-MRT) for mmW large MIMO* where it can offer 10-100 meters range in under-utilised spectrum: 10-100GHz carrier frequencies, offering extremely high spectral efficiency: The energy efficiency is achieved through spectral efficiency and cost efficiency much less complex than Singular Value Decomposition [MET14-D32].

#### 9.2.4.3 WP4

In this WP most of the components [MET13-D41] used for short and long term interference management can be potentially reuse for macro base layer services and also for BH service to UDN.

- *TeC3 - A2: Dynamic Nomadic Node Selection for Backhaul Optimization* Assess the performance in terms of backhaul link SINR, link rate, and end to-end rate distributions, in composite Fading/Shadowing Environments, and considering Co-channel Interference. Identification of the optimum nomadic cell based on the backhaul link quality.

#### 9.2.5 Extended UDN Concept – Macro cell in superior role to UDN

Macro network has an advantage of providing base layer services typically with very high coverage ratio. As it might be limited to the low data rates services, still it can be used for gaining additional benefits for UDN. This basic and reliable connectivity can be used for a smarter management of small cells/ UDN nodes w.r.t. to activation of idle nodes and traffic offloading or for more efficient radio resource utilization utilizing OTA messages.

##### 9.2.5.1 WP4

The following components [MET13-D41] provide novel concepts for the macro role in UDN and traffic management:

- *T4.3-TeC5: Self-management enabled by central database for energy savings in the Phantom Cell Concept (PCC)* In a heterogeneous network architecture where UEs support both connections to a macro cell and a small cell, it is proposed to equip each macro cell with a database that can aid any UE to choose the most appropriate small cell only based on the UE's reported geographic location information. For each small cell connected to a macro cell, information about the small cell channel quality (e.g. SNR, SINR or signal strength) is stored, mapped to sets of geographical coordinates (x, y). This way, UEs can always obtain an estimation of a small cell channel, even when the small cell is in sleep mode by making a request to the macro cell indicating their geographical position. If the small cell offering the best channel quality to serve a UE is in sleep mode, it can be woken up by the macro cell so that its connection procedures with the UE can be initiated. The approach may benefit from fast network synchronization and cross link interference mitigation.
- *T4.3-TeC6: Framework for control/user plane design with over-the-air signalling for UDN.* The main idea is to establish a framework for control/user plane split based on OTA signalling between macro and small cells. Two variants of control/user plane split are initially considered: Variant 1- all control plane signalling is handled by macro cells, except the signalling connected to link adaptation, HARQ, feedback for beam-forming. This means that the macro cell takes full control of the scheduling for the SCs which overhear the grants issued by the macro cell to take the right action; Variant 2 - all control plane signalling is handled by the SCs which forward channel information to the macro cell that in return defines constraints on the resources which SCs can use for scheduling.