

D3.8

Final Workshop on DISCUS architecture with supporting demonstrations

Dissemination Level: **PU**

- **Dissemination level:**

PU = Public,

RE = Restricted to a group specified by the consortium (including the Commission Services),

PP = Restricted to other programme participants (including the Commission Services),

CO = Confidential, only for members of the consortium (including the Commission Services)

Abstract:

In this Deliverable, we present a summary of the presentations shown in the DISCUS end of project workshop held during the European Conference on Optical Communications (ECOC) in Valencia (Spain), 27th October 2015. The workshop was entitled “Fibre access and core network evolution: what are the next steps towards an integrated end-to-end network?”. This workshop was supported with experimental demonstrations of a reconfigurable DWDM Long Reach PON setup in the ECOC exhibition at stand number 311.

COPYRIGHT

© Copyright by the DISCUS Consortium.

The DISCUS Consortium consists of:

Participant Number	Participant organization name	Participant short name	Country
Coordinator			
1	Trinity College Dublin	TCD	Ireland
Other Beneficiaries			
2	Alcatel-Lucent Deutschland AG	ALUD	Germany
3	Coriant R&D GMBH	COR	Germany
4	Telefonica Investigacion Y Desarrollo SA	TID	Spain
5	Telecom Italia S.p.A	TI	Italy
6	Aston Universtity	ASTON	United Kingdom
7	Interuniversitair Micro-Electronica Centrum VZW	IMEC	Belgium
8	III V Lab GIE	III-V	France
9	University College Cork, National University of Ireland, Cork	Tyndall & UCC	Ireland
10	Polatis Ltd	POLATIS	United Kingdom
11	atesio GMBH	ATESIO	Germany
12	Kungliga Tekniska Hoegskolan	KTH	Sweden

This document may not be copied, reproduced, or modified in whole or in part for any purpose without written permission from the DISCUS Consortium. In addition to such written permission to copy, reproduce, or modify this document in whole or part, an acknowledgement of the authors of the document and all applicable portions of the copyright notice must be clearly referenced.

All rights reserved.

Authors:

Name	Affiliation
Julio Montalvo	TID
Marco Ruffini	TCD
Andrea Di Giglio	TI

Internal reviewers:

Name	Affiliation
David Payne	TCD

Due date: 30th october 2015.

TABLE OF CONTENTS

1	INTRODUCTION	6
2	FIBRE ACCESS AND CORE NETWORK EVOLUTION: WHAT ARE THE NEXT STEPS TOWARDS AN INTEGRATED END-TO-END NETWORK?	7
3	SDN & NFV: REAL VALUE WITH NEW BUSINESS OPPORTUNITIES OR RESEARCH HYPE WITH UNMANAGEABLE COMPLEXITY?	13
4	DISCUS DEMO AT ECOC 2015 EXHIBITION	16
5	SUMMARY AND CONCLUSIONS	18
6	REFERENCES	19
	ABBREVIATIONS.....	21

1 Introduction

While FTTH is widely recognized as the ultimate goal of access network upgrade, the path towards its realization seems to differ among network operators, some of them planning direct FTTH deployment, while others are considering intermediate steps such as FTTCab or FTTCurb. In addition, due to the large increase in available bandwidth that new access technologies will bring, it becomes of paramount importance to understand how the network core should evolve to support such increases in user bandwidth. Recent studies point at end-to-end solutions, based on seamless integration of access and core as a means to develop architectures that are sustainable from a cost and energy consumption perspective, while providing the necessary capacity and flexibility to support forthcoming services and applications.

DISCUS [1] co-organized a major end of project workshop at ECOC 2015, entitled ["Fibre access and core network evolution: what are the next steps towards an integrated end-to-end network?"](#), in order to provide a discussion on the access, core and end-to-end network architecture evolution with two main objectives. The former is to identify the drivers for the different operators, pushing them towards different evolution plans both in the access and core development. The latter is to understand the current plans for network upgrading towards a tighter integration of access and core networks and the challenges and potential solutions for evolution towards next-generation architectures.

A main outcome of this workshop was to get an idea of the rationale behind the choices from different operators and vendors, whether there are common issues, misconceptions, etc.

DISCUS also co-organized a second workshop at the same conference venue, entitled ["SDN & NFV: Real value with new business opportunities or research hype with unmanageable complexity?"](#).

This workshop brought together views from ongoing research projects (e.g., STRAUSS, IDEALIST, DISCUS, COMBO) as well as Industrial actors (both network operators and vendors) on hot topics and current trends in Software Defined Networking (SDN) and Network Functions Virtualization (NFV).

In the following sections, a summary of the presentations shown in these workshops is reported. Final conclusions after the questions of the audience and the panel discussion are also provided.

2 Fibre access and core network evolution: what are the next steps towards an integrated end-to-end network?

The workshop was held in two consecutive sessions 13:30h-15:30h/16:00h-18:00h, Sunday 27th September, 2015, with an approximate audience of around 60 attendees.

The workshop started with a presentation from David Payne (TCD, Ireland & Aston University, UK), entitled “Introduction to end-to-end design principles and modelling within DISCUS”. After a brief introduction of the European FP7 [DISCUS project](#) [1] to the audience, Prof. Payne explained that, in order to face the current “investment crunch” in the networks, an end-to-end solution is required. As the network capacity has been decoupled from revenue growth, it is necessary to reduce network cost as far as possible and redistribute investment toward FTTH/P access. After presenting the DISCUS architecture, results on cash flow modelling and power consumption estimations were shown, pointing out that the DISCUS architectural proposal is a cost-effective and energy-saving approach. Among the different cost elements, the duct and cable of the fibre infrastructure are identified as the most relevant ones for the access network, and also showed that minimising upfront investment compared to just in time (JIT) investment was critically important for minimising time to a positive cash flow (positive return on capital investment).

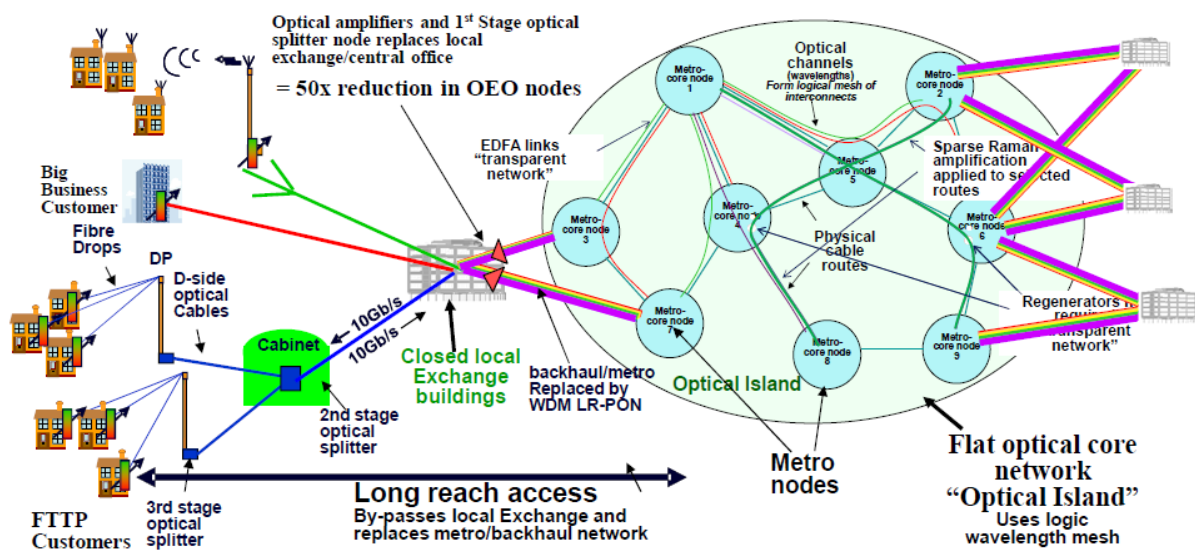

DISCUS ECOC Workshop 2015

Fig. 1. The DISCUS end to end architecture.

Regarding power consumption of the DISCUS nodes, OLT shelves are identified as the elements with largest consumption, followed by layer 3 routers/switches. Regarding

total power per user, it is dominated by ONU power, and the recent detailed model shows DISCUS to be lower power consumption than originally estimated at the beginning of the project.

The next presentation was from Juan Fernández-Palacios (Telefónica I+D, Spain) and Andrew Lord (British Telecom, United Kingdom), entitled “Control and data plane interoperability in elastic optical networks” [3]. In this presentation, Mr. Fernández-Palacios focused on the main building blocks for elastic optical networks: the programming switching and transmission elements (the data plane, formed by components such as Sliceable Bandwidth Variable Transponders S-BVT) and the network control software (the control plane). The control plane enables dynamic network provisioning and network resources optimization (transponders, client cards, etc.) in multi-vendor networks, enabling the data plane to be configured and provisioned by software. The implementation and integration of these blocks within the FP7 [IDEALIST project](#) [4] was described and a video of the implemented pan-european test-bed in operation was shown to the audience.

The audience asked the presenter about the typical data plane interoperability problems found, as well as which strategy options and technologies for a standard network controller can be used in the proposed scenario. Mr Fernández-Palacios identified a hierarchical approach using ABNO combining SDN and different control planes as the best strategy, using SDN extensions with proprietary and standard algorithms. Among the most relevant interoperability problems at the data plane, proprietary FEC and modulation formats were identified as the most relevant ones.

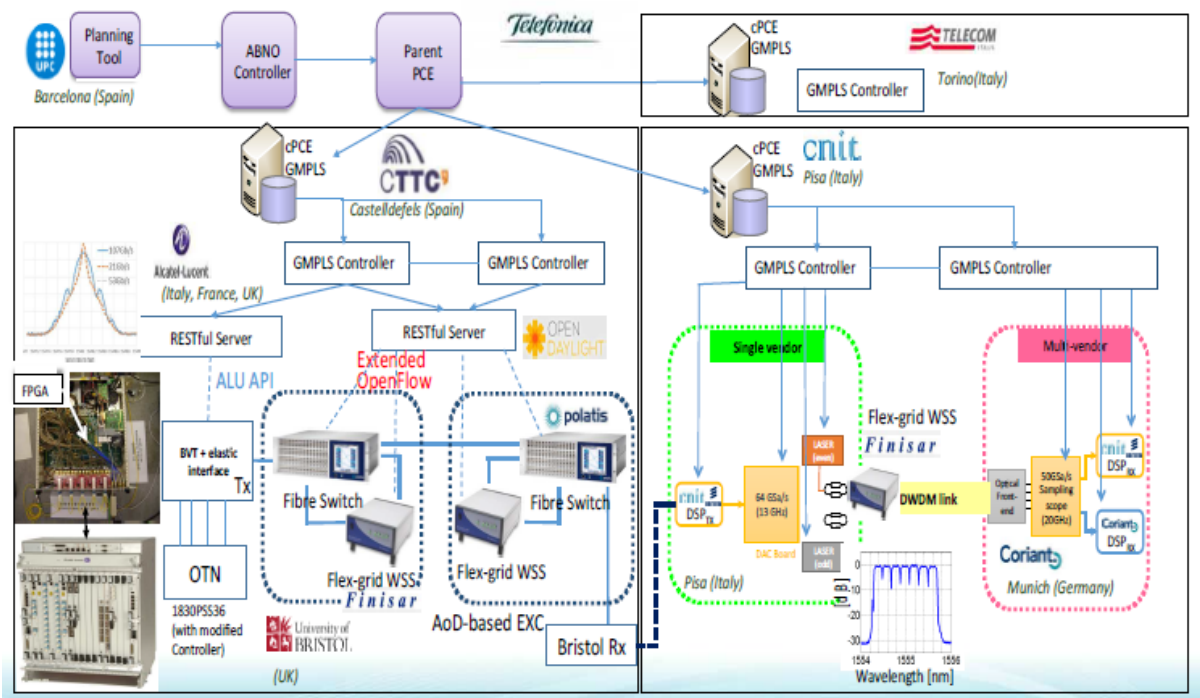

Fig. 2. Pan-european test-bed implemented within European FP7 project IDEALIST. (Courtesy of IDEALIST project).

Andrew Lord from BT discussed core network dimensioning, taking into account a 60% year over year broadband traffic increase following the wide deployment of

superfast (FTTCab broadband in the UK. BT vision foresees 500-1000 Mb/s speed peaks to be generalized to customers in around 10 years, and a committed information rate of 100 Mb/s to active users in 20 years.

The presentation “Fixed Access Network Sharing” [5] by Mr. Bruno Cornaglia (Vodafone) followed. Mr Cornaglia introduced Fixed Access Network Sharing (FANS) as a new concept that allows operators that are collaborating to jointly build an NGA network to mutually share their respective infrastructures in a more effective and efficient way. The current collaboration model today is based on bitstream access. This approach, according to the presenter, limits the possibility of new service creation and evolution of the network. A new collaboration model based on an Infrastructure provider (InP) and Virtual Network Operators (VNOs) is proposed.

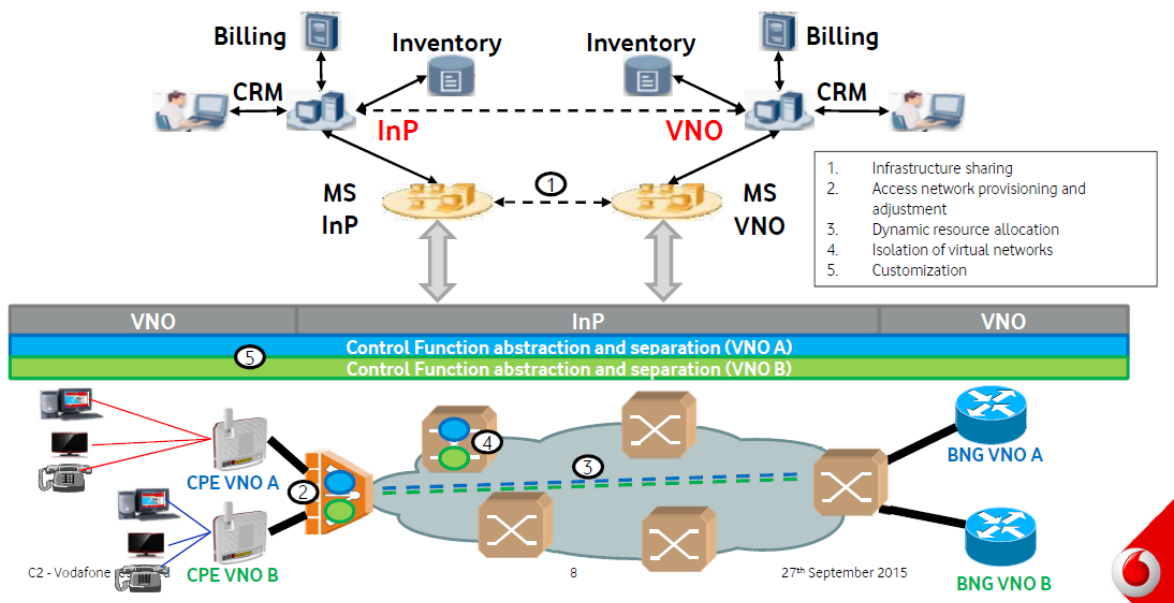

Fig. 3. End-to-end architecture of Fixed Access Network Sharing scenario. (Courtesy of Vodafone)

Mr. Cornaglia discussed the main solutions to achieve FANS:

- Via Management system of Infrastructure provider. This approach would require the standardization of the sharing interface and software upgrade, the standardization is starting in 2015 within the Broadband Forum (BBF) and expected to be finished in Q2/2017.
- By slicing network elements into different partitions, one per operator. This would require new hardware.
- By enhancing the solution with the introduction of SDN in order to allow more flexible control of the data plane by the different operators. This would also require new hardware but will achieve a maximum flexibility. This SDN enhancement is expected to be defined in BBF within Q2/2016 and Q4/2017.

The next presentation was from Dr. Thomas Pfeiffer (Alcatel-Lucent, Stuttgart), entitled “Technical challenges for next generation TWDM-PONs and on access network convergence” [6]. In his presentation, Dr. Pfeiffer identified two main challenges of TWDM-PONs, the crosstalk and the wavelength drift in upstream direction. Some

results and possible approaches to relax source spectral requirements and to mitigate the ONU laser drift were provided. Afterwards, some generic building blocks for a shared fibre infrastructure at the physical layer were presented, consisting of access points (AP) and Branching nodes (BN). In the future, the fibre infrastructure will become a managed entity in its own and APs and BNs implementations should take care of that in the long run. A near term example of a managed infrastructure for FTTx was also presented for the remote monitoring of optical splitters and demarcation points using an out-of-band ODN monitoring module (OMM) in a PON, see the following picture.

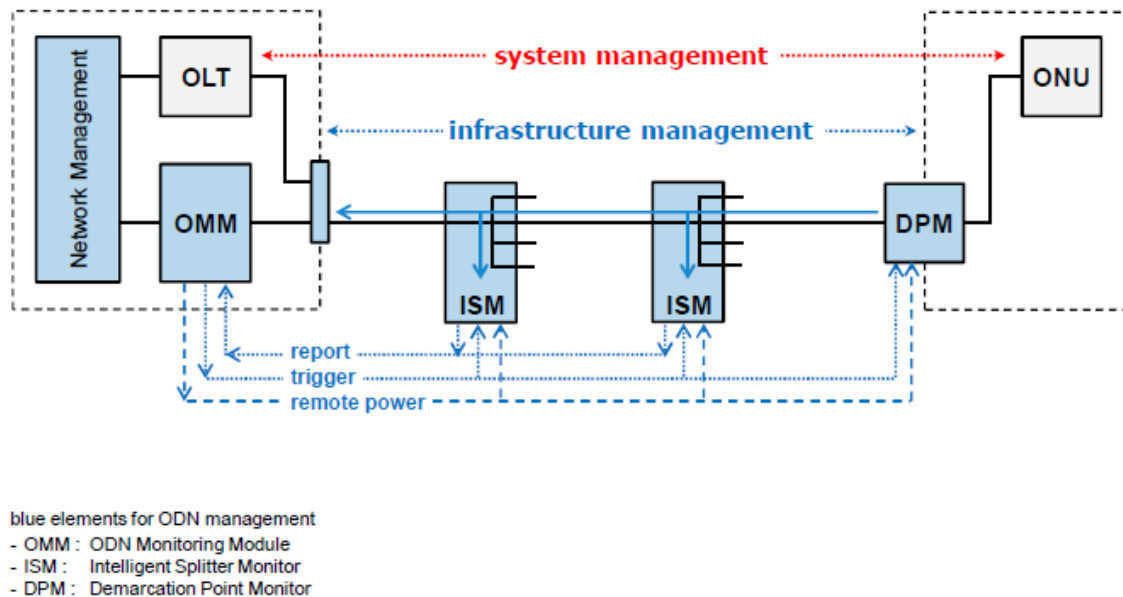

Fig. 4. A near term example of a managed infrastructure for FTTx. (Courtesy of Alcatel-Lucent)

Ari Sorsaniemi, Programme Officer of Network Technologies in the European Commission DG Connect, presented some updates in the European broadband policy and regulation with some relevant points related to Next Generation Access (NGA) networks [7]. Interestingly, draft work programme 2016-17 will probably include some research and innovation strands on optical core and optical support to access. The future ICT-07-2017 may also include a strand related to high capacity elastic optical networks, targeting the support of future traffic from 5G access networks.

In the next presentation from Dimitra Simeonidou (University of Bristol, UK), “Bristol is Open” (BIO) [8], a joint venture between Bristol-City-Council and University of Bristol, was presented. BIO is a research network integrating optical, wireless, IoT and computing to provide an open and experimental platform in the centre of Bristol. The BIO network includes an optical core network of 144-fibers connecting 4 nodes, as well as a cloud infrastructure, Wireless and IoT networks. BIO offers “City Experimentation as a Service” in order to support city-driven digital innovation.

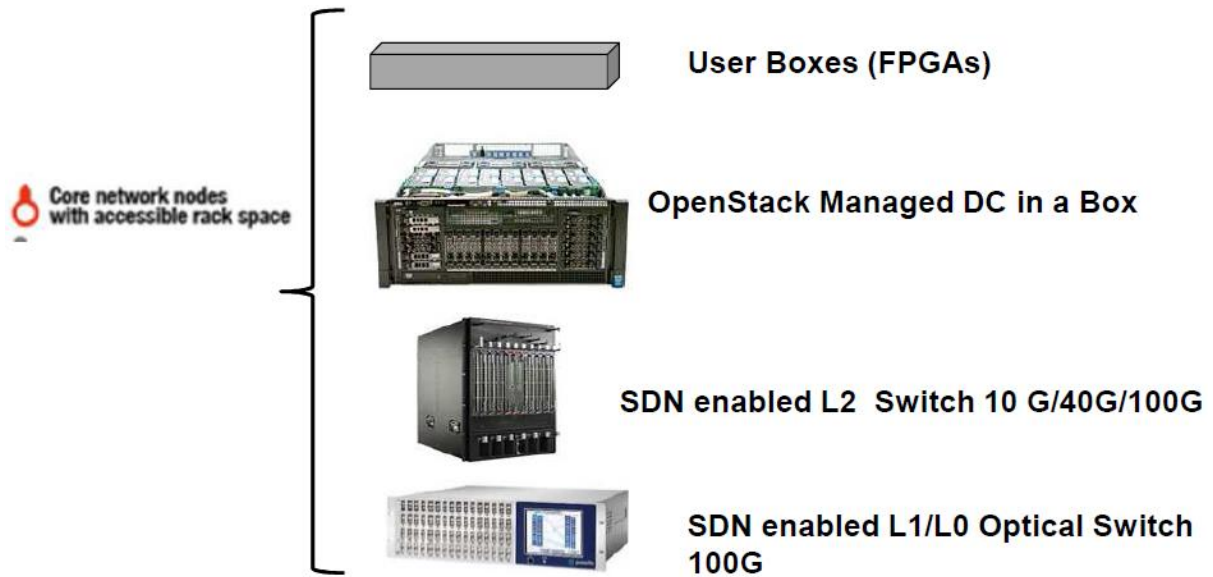

Fig. 5. “Bristol is Open” fibre network node.

In the presentation “How to face the emerging high capacity demand with cost, size and power efficient technologies” [9] by Jens Rasmussen (Fujitsu Laboratories Ltd., Japan), efficient transmission at 100Gb/s was discussed. For intermediate distances, cost-efficient 100G transceivers with Discrete Multi-Tone (DMT) modulation is proposed, while for long-reach, coherent 100G transceivers are considered the optimal solution.

The last presentation of the workshop was “Technologies and system solutions for enabling an integrated end-to-end network”, from Naoya Wada (NICT, Japan). In this presentation, Optical packet/circuit switching and extended reach PON technologies were presented as cost/power efficient approaches for an end to end network. 2x2 optical nodes for ring networks were presented and their key optical devices (burst-mode EDFA with optical feedback, high dynamic range packet receiver and electro-absorption switch) were analysed. Bidirectional 1-R repeaters for extended EPON with low-cost and low-power consumption (0.73W) were presented.



Fig. 6. Photo of the NICT experimental setup of an end-to-end network with optical packet/circuit switch nodes and extended-reach PON. (Courtesy of NICT)

3 SDN & NFV: Real value with new business opportunities or research hype with unmanageable complexity?

In parallel to the former workshop, this workshop was held in two consecutive sessions 13:30h-15:30h/16:00h-18:00h, Sunday 27th September, 2015.

Network programmability based on Software-Defined Networks (SDN) and Network Function Virtualization (NFV) is a major trend in optical network research and standardization. After the initial focus on the OpenFlow protocol as a new southbound interface to directly control the forwarding plane of packet switches, SDN is gaining increased importance as new networking paradigm allowing virtualization and programmability based on hardware abstraction and open programming interfaces. New SDN architectures and protocols are being proposed and discussed in the IETF, e.g. northbound protocols for topology dissemination and service orchestration. NFV is increasing the flexibility even further by moving network functions from dedicated hardware to virtual machines. These new degrees of flexibility pose a set of new challenges and research issues, ranging from service orchestration, security, reliability, network function performance monitoring, etc.

The main target of this workshop was to understand if and how SDN and NFV can simplify the way optical access and core networks are operated.

The first speaker was Ricard Vilalta (CTTC, Spain), In his presentation “SDN orchestration of multi-domain and multi-vendor transport networks” [11], Dr. Vilalta presented the FP7 European research project STRAUSS and some results of the project. STRAUSS proposes a system architecture based on Openflow controllers, a multi-domain network hypervisor running virtualization algorithms and a multi-domain SDN orchestrator. SDN/NFV is seen as a key for OPEX savings for Telcos as they are evolving towards IT companies. There seem to be business opportunities for a full new NFV ecosystem. Regarding complexity, SDN/NFV is definitely complex, but not unmanageable.

The next presentation was “An architecture, protocols and information models for SDN in FlexGrid Optical Networks”, by Adrian Farrel (Old Dog Consulting, United Kingdom) [12]. In this presentation, an architectural overview of Flexi-grid and SDN was done based on the ETSI RFC 7491 Application-Based Network Operations (ABNO) architecture. Path Computation Element (PCE) and Traffic Engineering Database (TED) are identified as key components. Standard data models of the network topology is also useful for moving the information between implementations, Netconf & Yang being used for that purpose.

In his presentation “SDN & NFV for Distributed Core seamlessly integrating wireless and fixed optical network” [13], Dr. Víctor López (Telefónica, Spain) discussed some network architectures for video content, which is the main driver in today’s networks. Actually, Telefonica is making a huge transformation in order to deliver High Definition (HD) video to its residential customers. With the massive adoption of HD video, today core traffic is expected to go from 1,5 Tb/s to 7,5 Tb/s. In order to address this, simplified architectures based on the combination of signalling and SDN concepts and an increased capacity by means of photonic transport technologies are required. The generic hierarchical architecture of network orchestration and network controllers

proposed within the DISCUS project in order to solve the end to end complexity was presented, see the following figure.

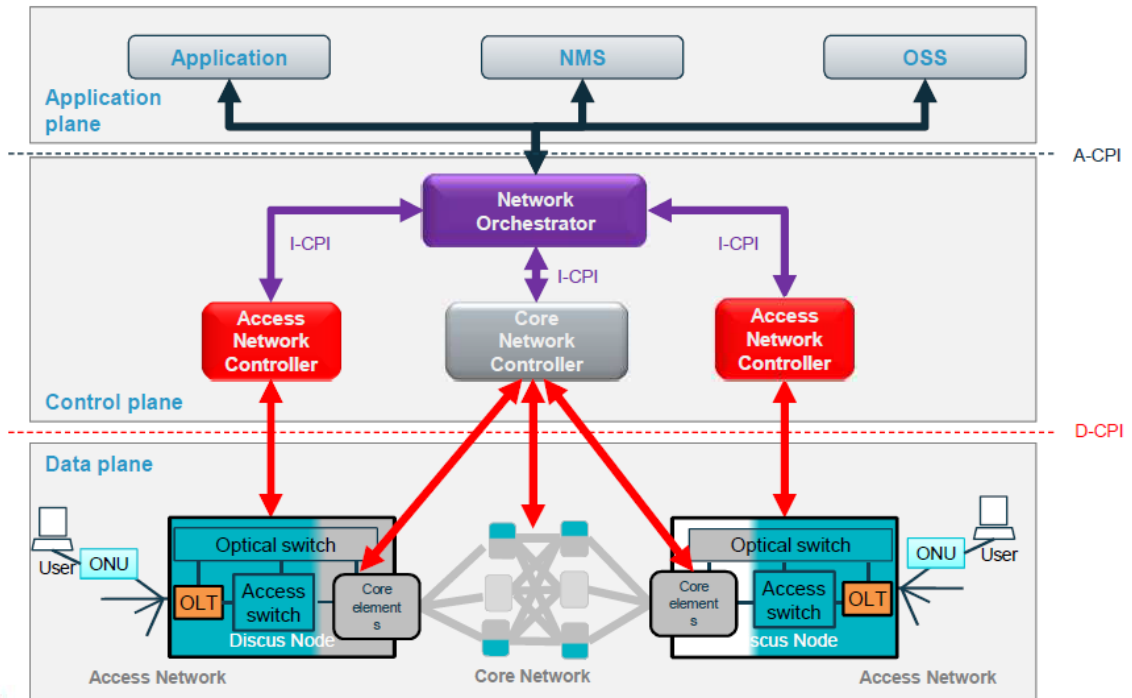

Fig. 7. DISCUS SDN/NFV control plane architecture.

The network orchestrator is defined as a parent controller or a centralized “controller of controllers”, handling the automation of end-to-end connectivity provisioning, working at a higher, abstracted level and covering inter-domain aspects between the access and the metro/core network. On the other hand, network controllers are in charge of controlling the access and core network elements. Some scenarios and use cases of the proposed control plane architecture were presented. Finally, the Control Orchestration Protocol (COP) was also introduced, with the target of allowing the interworking of heterogeneous control plane paradigms (OpenFlow, GMPLS/PCT).

The next presentation was from Stephan Pachnicke (ADVA Optical Networking, Germany), entitled “NFV-based Universal Access for Converged Fixed and Mobile Broadband Access/Aggregation Networks” [14]. In this presentation, the advantages of structural and functional convergence for Fixed Mobile Convergence (FMC) were described. Focusing on functional convergence, NFV advantages were described. Virtualization fits scenarios with intensive CPU processing and limited bandwidth, operating at higher OSI layers whereas dedicated hardware is preferred where there are limited gains from resource sharing, where performance and delay are critical and where static functions are deployed in high volume.

The presentation “Path determination as a key component of SDN and NFV for access, core, transport and IoT” [15] by Francesco Paolucci followed. In the presentation, the speaker reviewed the concept of the Path Computation Element (PCE), and showed the advantages of a reduced recovery time when using Openflow signalling instead of GMPLS. When generalizing the concept of path to flow/resource/service, the new concept of generalized PCE (gPCE) appears as an extended generalized PCE module

inside the SDN controller. Some novel path determination use cases in 5G networks (CRAN cooperative multipoint computation), NFV/datacentre networks and Internet of Things were described.

In the presentation “SDN and NFV from Japanese Carrier’s Point of View” from Takehiro Tsuritani (KDDI R&D Laboratories, Japan) [16], the speaker described the interest of KDDI in realizing NFV, in order to flexibly adapt to traffic demands changes, new business requirements (such as Machine-to-Machine and Mobile Virtual Network Operators), and to deploy sustainable and evolving network infrastructure. Proof of concepts for Mobile core network virtualization (vEPC: virtual Evolved Packet Core) and Transport SDN flexible optical metro/core/access networking performed by KDDI R&D were described.

Vinayak Dangui (Google, United States of America), in the presentation “SDN-based scalable optical network management: a case for OpenConfig YANG models” [17], described an approach for scaling, based on SDN, an optical network built on heterogeneous platforms and per-wavelength capacity granularity, static provisioning/configuration and proprietary systems. In order to do this, an informal industry collaboration of network operators, OpenConfig, was used as a way of quickly simplifying requirements for vendors and broaden use cases beyond any single operator/customer. OpenConfig define vendor neutral configuration and operational state models (written in YANG) based on real operations and published as open source via a public Github repository.

In the presentation “SDN-based Performance Monitoring for NFV Service Chaining” [18], Ming Xia (Ericsson Research, United States of America) reviewed the monitoring tools and products for networks and cloud infrastructures and described the opportunity of developing “Monitoring as a Service” using SDN/NFV techniques. The speaker showed an intent-based monitoring architecture and described a demo of a monitoring App based on OpenDayLight for a video stream traffic.

Finally, Dirk van den Borne (Juniper Networks, Germany), talked about centralized traffic engineering in multi-layer networks in his presentation “IP-Optical coordination” [19]. Instead of focusing on the typical terms (SDN, NFV, Cloud, etc...), the speaker focused directly on how to make networks more programmable to improve optimization and coordination between network layers. The speaker presented the Northstar architecture for multi-layer traffic engineering, and highlighted the need for abstraction of the network topology to allow topology exchange between server and client layers.

4 DISCUS Demo at ECOC 2015 exhibition

A transportable test-bed with a simplified version of the final DISCUS testbed [20] was prepared and shown at ECOC 2015 exhibition at stand n. 311 (Polatis). More than 50 visitors from more than 40 companies, universities and institutions (excluding DISCUS partners) visited the Polatis-DISCUS stand. The demo was disseminated in the DISCUS website and social networks (twitter, linkedin).

The physical layer of the portable demonstration consisted of a feeder fibre of 50km, an optical distribution network with a single amplifier node, 10km of access fibre one splitter and an attenuator to simulate the remaining ODN splitter loss. The metro/core node included the single-stage Polatis optical switch, the OpenFlow switch, an SDN access controller and two OLTs, as shown in figure 8.

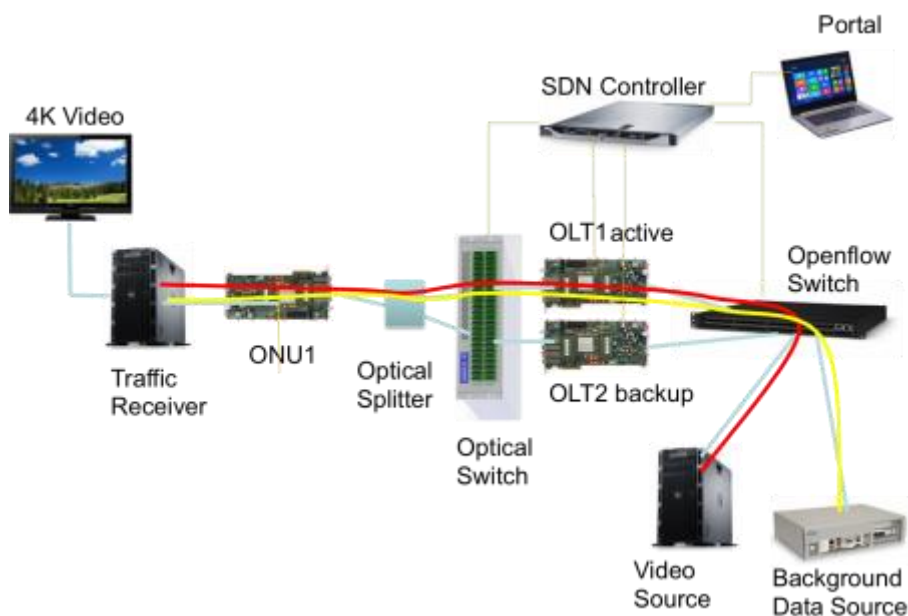

Fig. 8. Schematic of portable DISCUS Demo shown at ECOC Exhibition 2015.

Transmission of 4K video from the customer ONU through the LR-PON ODN and feeder fibre to the Metro-node based OLT using the long reach TDMA protocol developed within DISCUS was demonstrated. In addition, protection of the feeder fibre in a reconfigurable DWDM LR-PON was also demonstrated in this case the Polatis switch was used to simulate dual parenting protection between two metro-core nodes.

The technical details of the demos will be provided in deliverable D8.5.



Tweets Tweets y respuestas Fotos y vídeos

FP7 DISCUS IP @FP7_DISCUS_IP · 27 sept.
DISCUS will present a demonstration of a reconfigurable DWDM Long-Reach PON at #ECOC2015 at the Polatis stand n. 311 bit.ly/1KHtHcU

DISCUS will present a demonstration of a reconfigurable DWDM Long-Reach PON at ECOC 2015 at the Polatis both, number 311

More info at <http://www.discus-fp7.eu/news/2015/09/discus-will-present-demonstration-reconfigurable-dwdm-long-reach-pon-ecoc-2015-polatis>

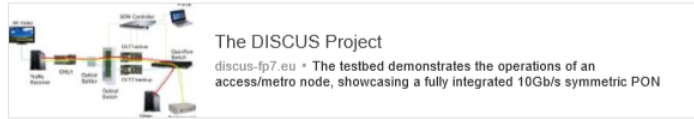

Comment (0) • Unlike (5) • Unfollow • Report spam

23 days ago

Avishek Nag, Sk Wasim Ali, Cemalettin Öztürk, +2 like this

Add a comment...

FP7 DISCUS IP @FP7_DISCUS_IP · 22 Jun.
DISCUS is co-organizer of two workshops (WS5, WS6) at #ECOC2015 in #Valencia on 27th sept, detailed programs here: bit.ly/1GvbHAu

FP7 DISCUS IP @FP7_DISCUS_IP · 9 Jun.
Telefonica trialling symmetric 10 Gbps FTTH Access bit.ly/1Mleppr



Home **News** Press Releases Dissemination Project Consortium Activities Login

The DISCUS Project

The DIStributed Core for unlimited bandwidth supply for all Users and Services (FP7 Grant Agreement 318137)

Home » News

News

DISCUS Will Present A Demonstration Of A Reconfigurable DWDM Long-Reach PON At ECOC 2015 At The Polatis Both, Number 311

The testbed demonstrates the operations of an access/metro node, showcasing a fully integrated 10Gb/s symmetric PON architecture comprised of physical layer transmission (with 10Gb/s burst mode components, wavelength reconfigurability, extended reach and switching technology) and Layer-2 protocols at the ONU and OLT, controlled by an SDN access control plane capable of satisfying on-demand user requests, such as 4K definition Video-on-Demand applications. The DISCUS showcase will also present the chosen architecture and the rationale for some of the recent modelling results.

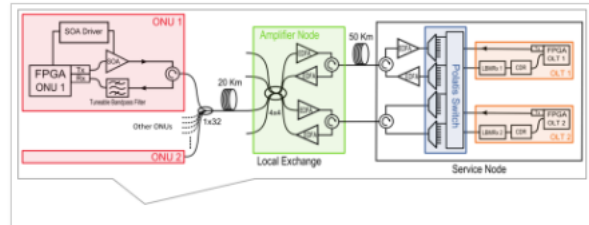

Fig 9. Captures of the social networks and DISCUS website disseminating the project demo.

5 Summary and conclusions

During the DISCUS workshops at ECOC, future technologies, standards and policies for end-to-end network with cost-efficient deployment and operations were proposed and discussed. Cost-efficient fibre infrastructure deployments, most especially in the access, will be mandatory in order to compensate for the decoupling of offered data traffic capacity and revenues for network operators, as well as to avoid the digital divide in rural areas. Infrastructures based on FTTP technologies, extended reach and high split ratios seemed to be agreed as mandatory by most of the speakers. These concepts are also the main principles of the DISCUS project for access networks.

Advanced fixed access network sharing approaches, overcoming current bitstream access limitations, were also discussed for collaborative multi-service provider access deployment scenarios. On this regard, network element slicing or partitioning could be achieved in a flexible and cost-efficient way by the DWDM/TWDM-PON technologies and Metro-core node architecture proposed within DISCUS, and this also enables SDN enhancement. The monitoring and management of the fibre infrastructure as an entity of its own was also anticipated in the workshop. In the photonic core, elastic optical networks with multi-vendor and multi-layer interoperability were also discussed and demonstrated by EU FP7 project IDEALIST.

Programmability of the network was also discussed in detail by the workshop devoted to SDN/NFV. Speakers seemed to agree that SDN/NFV technologies have a manageable complexity and can be actually useful for cost-efficient and flexible services deployment and operations in future networks.

6 References

- [1] FP7 DISCUS project. <http://www.discus-fp7.eu/>
- [2] David Payne, "Introduction to end-to-end design principle and modelling within DISCUS", Workshop presentation, 41st ECOC, 27th September, 2015, Valencia (Spain).
- [3] Juan Fernández-Palacios and Andrew Lord, "Control and data plane interoperability in elastic optical networks", Workshop presentation, 41st ECOC, 27th September, 2015, Valencia (Spain).
- [4] FP7 IDEALIST project. <http://www.ict-idealists.eu/>
- [5] Bruno Cornaglia, "Fixed Access Network Sharing". Workshop presentation, 41st ECOC, 27th September, 2015, Valencia (Spain).
- [6] Thomas Pfeiffer, "Technical challenges for next generation TWDM-PONs and on access network convergence", Workshop presentation, 41st ECOC, 27th September, 2015, Valencia (Spain).
- [7] Ari Sorsaniemi, "Challenges for development of fast broadband, EU targets, digital divide and regulatory perspectives", Workshop presentation, 41st ECOC, 27th September, 2015, Valencia (Spain).
- [8] Dimitra Simeonidou, "Bristol is Open: A city infrastructure pioneering SDN and flexible/programmable optical technology enablers for future end-to-end smart city services", Workshop presentation, 41st ECOC, 27th September, 2015, Valencia (Spain).
- [9] Jens Rasmussen, "Technologies and system solutions for enabling an integrated end-to-end network", Workshop presentation, 41st ECOC, 27th September, 2015, Valencia (Spain).
- [10] Naoya Wada, "Technologies and system solutions for enabling an integrated end-to-end network", Workshop presentation, 41st ECOC, 27th September, 2015, Valencia (Spain).
- [11] Ricard Vilalta, "SDN orchestration of multi-domain and multi-vendor transport networks", Workshop presentation, 41st ECOC, 27th September, 2015, Valencia (Spain).
- [12] Adrian Farrel, "An architecture, protocols and information models for SDN in FlexGrid Optical Networks", Workshop presentation, 41st ECOC, 27th September, 2015, Valencia (Spain).
- [13] Víctor López, "SDN & NFV for Distributed Core seamlessly integrating wireless and fixed optical network", Workshop presentation, 41st ECOC, 27th September, 2015, Valencia (Spain).

- [14] Stephan Pachnicke, “NFV-based Universal Access for Converged Fixed and Mobile Broadband Access/Aggregation Networks”, Workshop presentation, 41st ECOC, 27th September, 2015, Valencia (Spain).
- [15] Francesco Paolucci, “Path determination as a key component of SDN and NFV for access, core, transport and IoT”, Workshop presentation, 41st ECOC, 27th September, 2015, Valencia (Spain).
- [16] Takehiro Tsuritani, “SDN and NFV from Japanese Carrier’s Point of View”, Workshop presentation, 41st ECOC, 27th September, 2015, Valencia (Spain).
- [17] Vinayak Dangui, “SDN-based scalable optical network management: a case for OpenConfig YANG models”, Workshop presentation, 41st ECOC, 27th September, 2015, Valencia (Spain).
- [18] Ming Xia, “SDN-based Performance Monitoring for NFV Service Chaining”, Workshop presentation, 41st ECOC, 27th September, 2015, Valencia (Spain).
- [19] Dirk van den Borne, “IP-Optical coordination”, Workshop presentation, 41st ECOC, 27th September, 2015, Valencia (Spain).
- [20] “Report on the critical system components and subsystems”, DISCUS Deliverable D8.1, Oct. 2014.

Abbreviations

ABNO	Application-based Network Operations
AP	Access Point
BBF	BroadBand Forum
BIO	Bristol is Open
BN	Branching Node
BT	British Telecom
COP	Control Orchestration Protocol
DMT	Discrete Multi-Tone
DPM	Demarcation Point Monitor
DWDM	Dense Wavelength Division Multiplexing
ECOC	European Conference on Optical Communications
EDFA	Erbium-Doped Fiber Amplifier
EPON	Ethernet PON
FANS	Fixed Access Network Sharing
FMC	Fixed-Mobile Convergence
FTTH	Fiber to the Home
FTTP	Fiber to the Premises
gPCE	Generalized PCE
HD	High Definition
InP	Infrastructure Provider
ISM	Intelligent Splitter Monitor
IoT	Internet of Things
NFV	Network Function Virtualization
NGA	Next Generation Access
ODN	Optical Distribution Network
OMM	ODN Monitoring Module
OLT	Optical Line Termination
ONU	Optical Network Unit
PCE	Patch Computation Element
PON	Passive Optical Network
S-BVT	Sliceable Bandwidth Variable Transponder

SDN	Software Defined Networking
TED	Traffic Engineering Database
vEPC	Virtual Evolved Packet Core
VNO	Virtual Network Operator

Document versions

Version ¹	Date submitted	Comments
V1.0	04/11/2015	First version sent to the EU.

¹ Last row represents the current document version