



VOIce-based Community-cEntric mobile Services for social development

Grant Agreement Number 269954

**Deliverable No D2.1**  
**Technical requirements**

September 2011

---

**SEVENTH FRAMEWORK PROGRAMME**  
THEME ICT-2009.9.1 – International cooperation



## PROJECT DELIVERABLE REPORT

Project	
Grant Agreement number	2699542
Project acronym:	VOICES
Project title:	<i>VOIce-based Community-cEntric mobile Services for social development</i>
Funding Scheme:	<i>Collaborative Project</i>
Date of latest version of Annex I against which the assessment will be made:	<i>18 February 2011</i>
Document	
Deliverable number:	D2.1
Deliverable title	Technical Requirements
Contractual Date of Delivery:	September 2011
Actual Date of Delivery:	30 September 2011
Editor (s):	Morgan Richomme (FT)
Author (s):	Morgan Richomme (FT), Arnaldo Santos (PTIN), Stéphane Boyera (Web Foundation), David Blaisonneau (FT), Philippe Bretier (FT)
Reviewer (s):	FT, PTIN, TNO, Web Foundation
Work package no.:	WP2
Work package title:	Voice platform & toolbox
Work package leader:	FT
Work package participants:	Web Foundation, FT, CSR4, ESMT, PTIN
Distribution:	PU
Version/Revision:	1.1
Draft/Final:	Final
Total number of pages (including cover):	39
Keywords:	Platform, configuration, components, architecture

**1 CHANGE LOG**

<b>Reason for change</b>	<b>Issue</b>	<b>Revision</b>	<b>Date</b>
First draft release	0.1	1	02/09/11
Change plan + France Telecom internal comments	0.2	1	06/09/11
Comments P.Bretier (FT)	0.3	1	11/09/11
Add crowd-sourcing feature	0.4	1	15/09/11
Comments from P.Cabral Pinto review	0.5	1	22/09/11
Comments from S.Boyera review	0.6	1	26/09/11
New chapter introduction, refactoring of summary, mention of festival	0.7	1	28/09/11
First official release	1.0	1	29/09/11
Formatting errors amended	1.1	1	12/3/12

## 2 DISCLAIMER

This document contains description of the VOICES project work and findings.

The authors of this document have taken any and all available measures in order for its content to be accurate, consistent and lawful. However, neither the project consortium as a whole nor the individual partners that implicitly or explicitly participated in the creation and publication of this document hold any responsibility for actions that might occur as a result of using its content.

This publication has been produced with the assistance of the European Union. The content of this publication is the sole responsibility of the VOICES consortium and can in no way be taken to reflect the views of the European Union.

The European Union is established in accordance with the Treaty on European Union (Maastricht). There are currently 27 Member States of the Union. It is based on the European Communities and the member states cooperation in the fields of Common Foreign and Security Policy and Justice and Home Affairs. The five main institutions of the European Union are the European Parliament, the Council of Ministers, the European Commission, the Court of Justice and the Court of Auditors. (<http://europa.eu.int/>)



**VOICES is a project funded in part by the European Union.**

## 3 Table of Contents

<b>1 CHANGE LOG</b> .....	3
<b>2 DISCLAIMER</b> .....	4
3 Table of Contents .....	5
<b>4 ACRONYMS</b> .....	7
<b>5 SUMMARY</b> .....	8
<b>6 INTRODUCTION</b> .....	9
<b>7 TECHNICAL REQUIREMENTS</b> .....	10
7.1 Technical needs.....	10
7.1.1. WP4 m-Health .....	10
7.1.2. WP5 m-Agri.....	10
7.2 From technical needs to technical requirements .....	10
7.3 Focus on new infrastructure .....	11
7.4 Focus on new vocal and media features .....	11
<b>8 PLATFORM ARCHITECTURE</b> .....	13
8.1 Introduction .....	13
8.2 Organic architecture .....	13
8.3 Functional architecture.....	16
8.3.1. Gateway.....	16
8.3.2. Core platform high level design .....	16
8.3.3. Focus on the components.....	19
<b>9 New Voices generic features</b> .....	23
9.1 Platform adaptations for VOICES.....	23
9.1.1. New infrastructure .....	23
9.1.2. New features .....	23
9.2 Generic features and Emerginov .....	25
9.3 Functional features and Emerginov .....	26
<b>10 Platform planning</b> .....	28
<b>11 Developing on the Emerginov platform</b> .....	30
11.1 Emerginov account.....	30
11.2 Personal account.....	31
11.3 Create a new project .....	32
11.4 Subscribe to APIs .....	32

11.5	Code and upload the code.....	33
11.6	Deploy the code .....	34
11.7	Test .....	34
<b>12</b>	<b>CONCLUSION .....</b>	<b>36</b>
<b>13</b>	<b>APPENDIX-A: USE CASE VERSUS EMERGINOV .....</b>	<b>37</b>
13.1	Use case #1: m-Health (WP4).....	37
13.2	Use case #2: m-Agri (WP5).....	38
<b>14</b>	<b>REFERENCES.....</b>	<b>39</b>

## Index of Tables

Table 1:	Technical needs.....	11
Table 2:	Description of the VMs .....	19
Table 3:	Main components of the VM content.....	20
Table 4:	main components of the VM Dev.....	21
Table 5:	main components of the VM Media.....	21
Table 6:	Main components of the VM Routing .....	22
Table 7:	Generic features .....	26
Table 8:	Functional features .....	27
Table 9:	WP4 requirements .....	38
Table 10:	WP5 requirements .....	38

## 4 ACRONYMS

**API: APPLICATION PROGRAMMING INTERFACE**

**ASR: AUTOMATIC SPEECH RECOGNITION**

**GPL: GNU PUBLIC LICENSE**

**HTTP: HYPERTEXT TRANSFER PROTOCOL**

**IP: INTERNET PROTOCOL**

**NAS: NETWORK ACCESS STORAGE**

**NFS: NETWORK FILE SYSTEM**

**OS: OPERATING SYSTEM**

**PLMN: PUBLIC LAND MOBILE NETWORK**

**PSTN: PUBLIC SWITCHED TELEPHONE NETWORK**

**RTP: REAL TIME PROTOCOL**

**SIP: SESSION INITIATION PROTOCOL**

**SMS: SHORT MESSAGE SERVICE**

**SSH: SECURE SHELL**

**SSML: SPEECH SYNTHESIS MARKUP LANGUAGE**

**SVN: SUBVERSION**

**TTS: TEXT-TO-SPEECH**

**USB: UNIVERSAL SERIAL BUS**

**VM: VIRTUAL MACHINE**

**VOIP: VOICE OVER IP**

**VXML: VOICE EXTENSIBLE MARKUP LANGUAGE**

## 5 SUMMARY

The VOICES project intends to deliver a toolbox for the development of voice services enabling a voice-based access to content and mobile ICT services. Taking into account the technical needs, reported in the document VOICES-D1.5 [1], and based on the derived technical requirements, the Emerginov platform was selected as a voice-based service facilitator.

This document deals with the organic and functional architecture of the platform and details how the VOICES use cases can be accomplished by enhancing the existing Emerginov platform. The modus operandi for platform configuration, administration and components integration is here described.



## 6 INTRODUCTION

The VOICES project intends to take a major step forward in achieving the potential of mobile ICT services particularly in the African context and resolve key challenges outlined in the Mobile Web for Social Development Roadmap. To this end, the one of the VOICES main objective is to deliver a toolbox for the development of voice services enabling a voice-based access to content and mobile ICT services.

This Deliverable presents the technical architecture of the platform functionally defined in WP1. The goal is to provide a platform that supports all the identified technical needs. Due to its capabilities, the Emerginov platform was selected as the basis to enable the creation of innovative voice-based services. The platform is composed of hardware and a software environment. It is here presented the description of the platform and the required enhancements to support the VOICES scenarios.

This Deliverable also describes the modus operandi for platform configuration, administration and components integration. The toolkit provides the interface between developers and the platform. It allows internal as well as third party developers to quickly and easily invoke the APIs through a unique and secure access point, to develop services.

The rest of the Deliverable is organized as follows: it will provide a summary of the use cases and focus on the technical requirements; it provides an overview of the platform and describes the work done to fulfil all the technical requirements; it depicts the roadmap related to the infrastructure; it details how developers could interact with the platform and finally, summarizes the main conclusions.

## 7 TECHNICAL REQUIREMENTS

### 7.1 Technical needs

The technical needs have been fully described in [1], they may however be summarized as follow:

#### 7.1.1. WP4 m-Health

This use case deals with Health in Senegal for users without any internet access.

The goals are the management of:

- Daily medical data to be uploaded in a central database
- Medical quiz
- An information letter

#### 7.1.2. WP5 m-Agri

This use case deals with Agriculture in Mali for users without any internet access.

The solution consists in:

- a market information system
- a M-Event organizer for re-greening events

The technical requirements lead to adopt an existing platform and to adapt it for the project. The platform will be described in the next chapters, as well as the necessary adaptations for the context of the project. .

### 7.2 From technical needs to technical requirements

The technical needs [1] may be summarized in the table below:

Multi channel accessibility	Fixed and mobile calls - Senegal	R.1.1
	SMS - Senegal	R.1.2
	Internet - Senegal	R.1.3
	Fixed and mobile calls - Mali	R.1.4
	SMS - Mali	R.1.5
	Internet - Mali	R.1.6
Service hosting	Service execution	R.2.1

	File hosting	R.2.2
	Database	R.2.3
	DAM	R.2.4
	Crowd sourcing tool	R.2.5
Voices tools	IVR	R.3.1
	ASR	R.3.2
	TTS	R.3.3
Developers needs		R.4.1
Administration needs		R.5.1
Mobile Applications		R.6.1

*Table 1: Technical needs*

Moreover, the architecture main goals were also mentioned:

- Flexibility (R.7.1)
- Reachability (R.7.2)
- Accessibility (R.7.3)
- Openness and Re-usability (R.7.4)
- Long-term sustainability (R.7.5)

It was decided to reuse an existing platform dedicated to innovation in Africa called Emerginov. This choice was motivated because the platform was already answering some of the requirements listed below. Moreover, this platform, based on free software, provides guarantees in term of long-term sustainability. This platform will be detailed in the following chapters. However major work was required to adapt the platform to local context (Senegal and Mali) focusing on vocal technologies, and to add new features according to the requirements of the projects. It was also necessary to deploy it locally, in Senegal and Mali.

### 7.3 Focus on new infrastructure

WP4 and WP5 lead to the installation of local gateways in order to route calls and SMS locally, respectively in Senegal and Mali.

### 7.4 Focus on new vocal and media features

#### VXML

Initially the platform was only dealing with Asterisk as media server.

VOICES – N° 269954

[www.mvoices.eu](http://www.mvoices.eu)

All the vocal services had to be created using proprietary languages of this component. VXML was required to offer a more flexible vocal development environment and to simplify the developments of the media services.

### TTS

Text-To-Speech function was required in local languages, i.e. in Bambara for the use cases in Mali and in Wolof for those in Senegal. These two languages were not available in existing TTS solution. Therefore Bambara and Wolof languages and voices must be created (WP3).

### ASR

An ASR component is required to perform vocal recognition tasks in Wolof and in Bambara. It shall be integrated in the framework.

### Media library/DAM (Digital Asset Management)

In order to build easily new voices for TTS and lexicon for ASR, it is necessary to collect lots of media segments. Media Segment could be texts with phonological annotations and audio recordings from different speakers in different languages.

### Crowd sourcing framework

A framework of crowd sourcing shall be also integrated in order to simplify and speed up the collection of vocal segments. The media library is used to store them, the crowd-sourcing tool is used to collect them.

## 8 PLATFORM ARCHITECTURE

### 8.1 Introduction

The platform used for VOICES is known as Emerginov platform. This platform consists in the smart integration of free software components. It is a virtualized core platform hosting specialized virtual machines connected to a distributed set of Telecom gateways. In this chapter, we will detail this architecture.

### 8.2 Organic architecture

The Organic architecture of the solution may be described as follow:

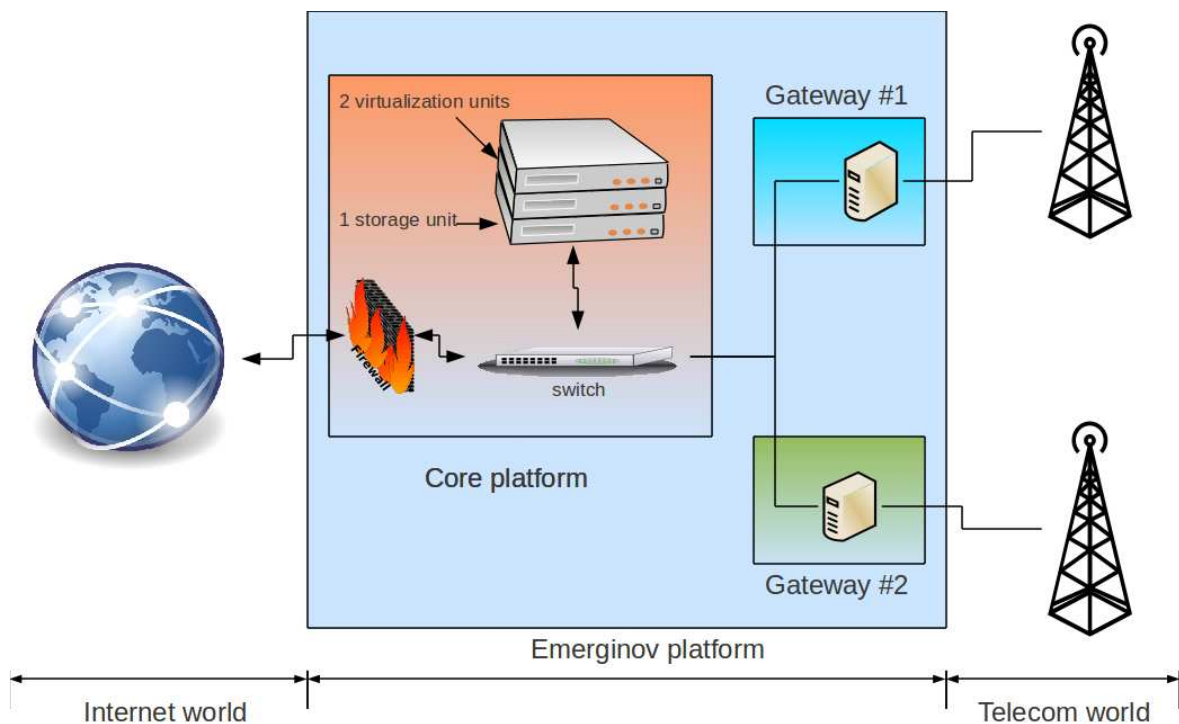

*Illustration 1: Organic architecture*

The platform can be divided into

- a core platform
- gateways

The core platform is a centralized platform. This core part includes:

VOICES – N° 269954

[www.mvoices.eu](http://www.mvoices.eu)

- 2 machines (IBM 3550M2) for virtualization management (XEN server); these machines will host the core applicative parts in different virtual machines. The virtualization layer is realized by XEN. 1 machine (RAID 1) is dedicated to the lived virtual machine.
- 1 machine (x3650M2) is used as NFS server (RAID5) for storage and backup.
- 1 machine (QNAP) for the storage of the different contents produced on the platform.

A gateway is a standard PC on Debian with additional cards connected to the operator network.

In the context of the project VOICES, the core gateway is located in Dakar hosted by Sonatel multimedia. 2 gateways will be available, one in Senegal and one in Mali.

Basic standard elements are also used

- a firewall
- a NTP server for time synchronization of all the machines
- a switch (24 ports)
- a DNS server

The technical architecture may be described as follow:

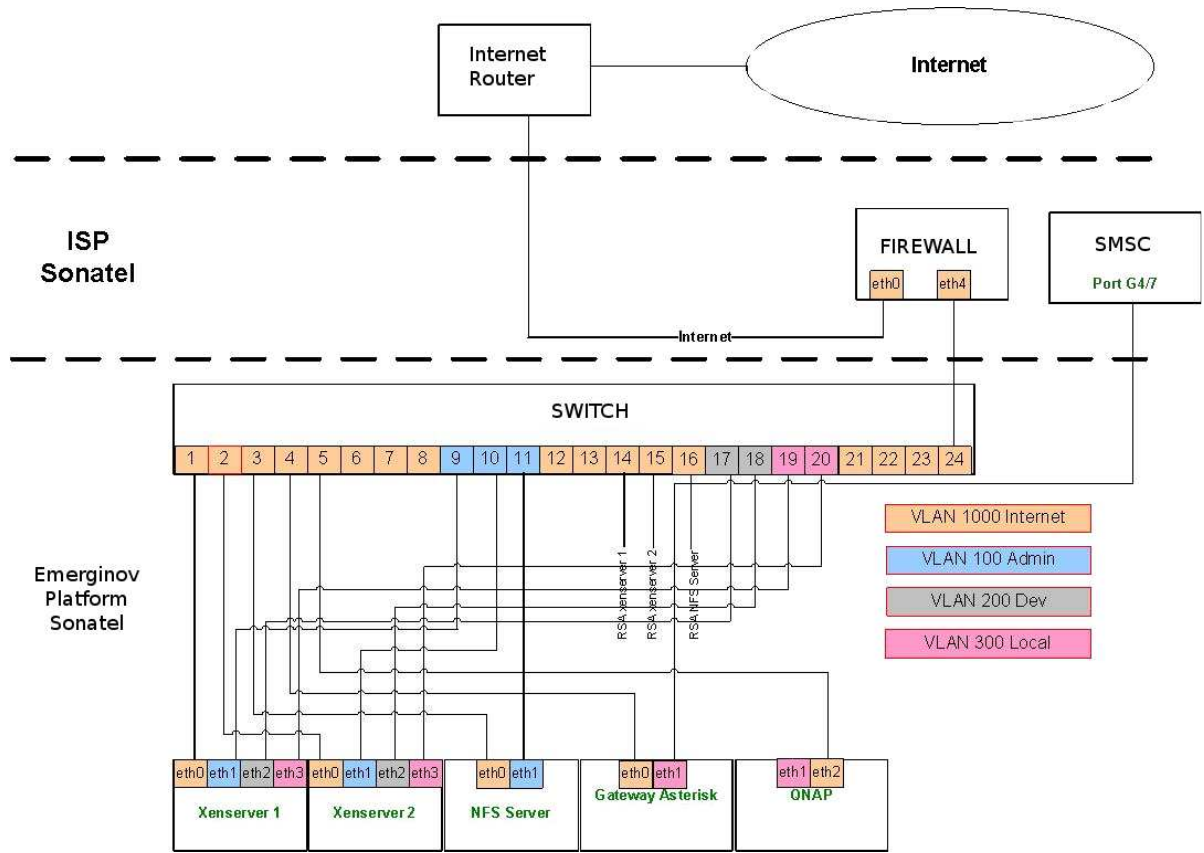

Illustration 3: Technical architecture

### 8.3 Functional architecture

The Emerginov platform is an IP multimedia platform offering a large set of features. This platform is open to developers and aims to support micro services from the conception to the production in experimental context. Concretely a developer can access to the platform, provide his/her code, and deploy it from a web interface.

#### 8.3.1. Gateway

The functional architecture of a gateway may be described as follow:

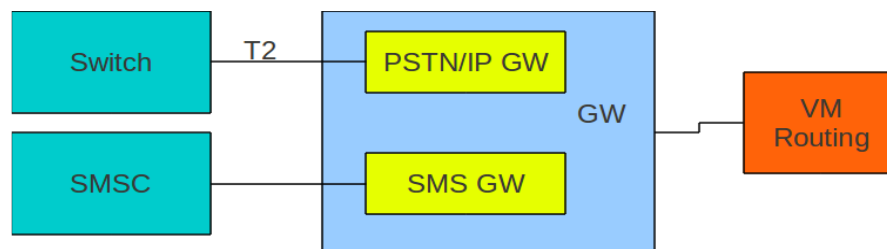

Illustration 4: Gateway description

Each gateway provides 2 types of connection

- SMS gateway: the gateway is connected to the SMS-C of the operator and allow the sending and reception of SMS with local numbers
- Voice gateway: the gateway is connected to a T2 allowing vocal services through a range of local routable phone numbers associated to this T2

N gateway(s) can be connected to one core platform.

#### 8.3.2. Core platform high level design

The very high level design may be described as follow:

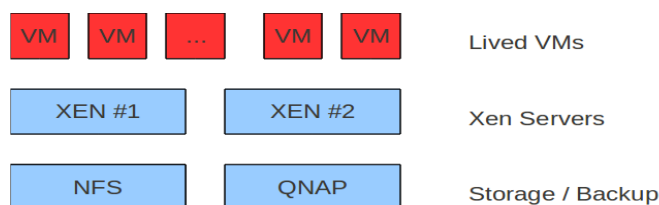

Illustration 5: Core platform very high level description

The NFS server is used for storage and backup of the Virtual machines (VMs)

The QNAP is used for content storage (NAS).



Let us focus on the applicative virtualization layer. The following figure provides an overview of the different virtual machines.

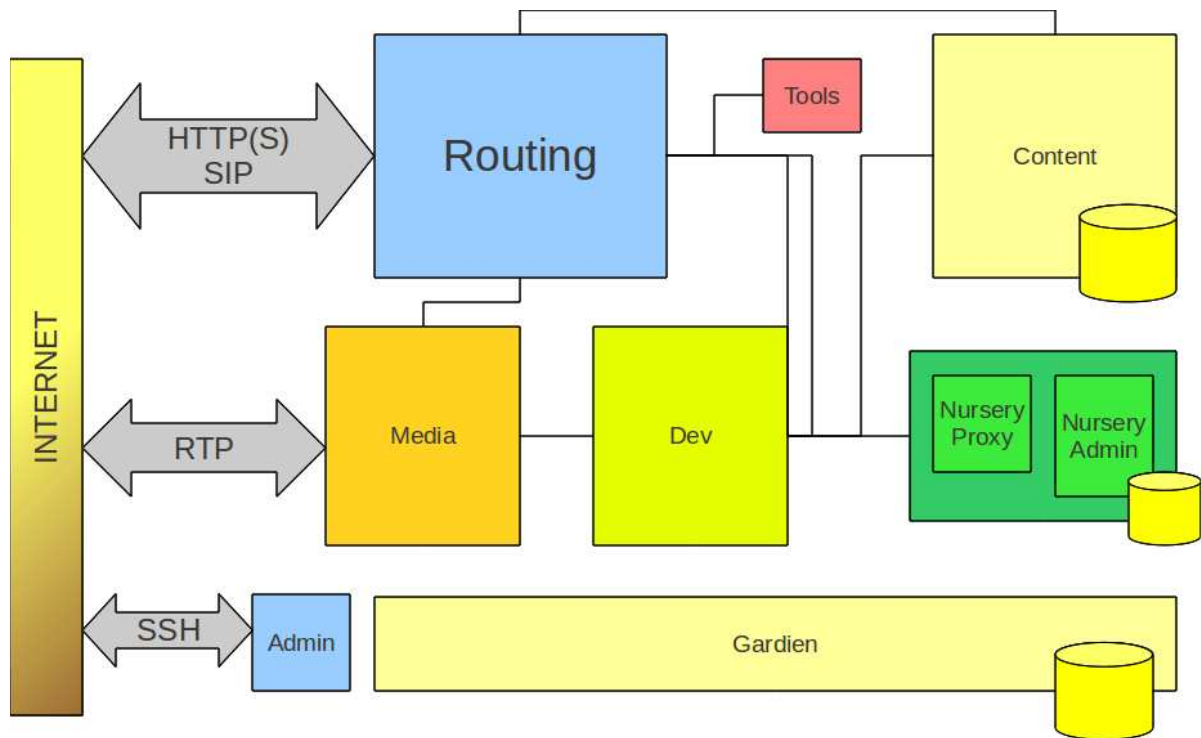

*Illustration 6: Virtual machines on the core platform*

The virtualized layer deals with 9 virtual machines:

- routing
- media
- content
- dev
- admin
- gardien
- tools
- nursery admin
- nursery proxy

All the VM (except Nursery proxy) are based on Debian Lenny. There are 2 types of partition:

- Basic: / 512 /home 1200, /tmp 512, /usr 1400, /var 3100

- Extended: / 512, /home 1200, /tmp 512, /usr 3800, /var 5500

Nursery proxy is based on CentOS.

Each virtual machine deals with 4 virtual network interfaces:

- Public: flows between the core platform and the public network
- Admin: internal administration flow
- Priv: internal private flows
- Dev: internal flows from developers

VM	Description	Features
Admin	This small VM is used as SSH rebound. It is the entry point for any SSH connection from Internet.	SSH
Content	This VM deals with all the content aspects either for the internal applications (social network, e-education, Voice over IP, TV portal) or for the code source of the developers. This VM is connected to the storage unit The content VM can also be used to host DAM (Digital Asset management)	content database web server social network SVN (code storage) tracker TV portal DAM crowd sourcing web framework
Dev	This VM is dedicated to the developer web applications. The code stored on the content VM is deployed on the Dev VM.	web server
Gardien	This VM is the administration VM, it includes several applications used by the the administrators of the platform.	admin database web server VoIP admin interface registration unit DNS mail server supervision
Media	This media includes all the media elements. The main element is the media server with VXML capabilities. It also includes the webradio. The J2EE server is also hosted on this VM. The framework adhearsion allows also a simple usage of the Asterisk API (click to call, control of the conference bridge,..) Julius is used with Asterisk for the ASR function.	media server (conference bridge, IVR, VXML, ASR) IVR API web radio J2EE
Nursery Admin	The nursery is the API shop of the platform. The admin part deals with the management of the users	API database web server
Nursery proxy	The proxy part manages the APIs provided through the	Proxy HTTP

	web interface hosted in the admin part.	
Routing	The routing VM is the entry point for the web (HTTP) and Telecom flows (SIP or SMS).	Proxy HTTP Proxy SIP proxy SMS
Tools	This VM is used to host stand alone applications such as webconference. As the platform is an innovation platform, a tool for free meeting and free exchange was required. It has been installed on a dedicated VM.	WebConference

Table 2: Description of the VMs

### 8.3.3. Focus on the components

The Emerginov platform consists in the smart integration of free software components. These components will be detailed in the following tables. The nursery integrates a non free software element because it was already part of the orange nursery product. A 100% free software platform, substituting the non free software elements with open source elements is planned in order to allow the externalisation of the Emerginov platform towards a complete free software project. But it requires some adaptation and could not be performed before 2012.

Moreover the nursery exposes API that are open but not open source. For instance the Text-To-Speech API is based on Baratinoo, an Orange project. It is provided freely through the nursery but it is not a free software solution.

The main components are described per VM. We focused on the main VMs:

- Content
- Dev
- Media
- Routing

Please note that all the packages/libraries of the Debian Lenny OS are not mentioned, see <http://www.debian.org/releases/lenny/i386/release-notes/> for details. All the php libraries are also not mentioned.

VM Content	Component	Version
Database	mysql-common	5.0.51a-24+lenny4
	mysql-server	5.0.51a-24+lenny4
	mysql-server-5.0	5.0.51a-24+lenny4

PHP	php5	5.2.6.dfsg.1-1+lenny9
	php5-mysql	5.2.6.dfsg.1-1+lenny9
	phpmyadmin	4:2.11.8.1-5+lenny6
Web server	Apache2	2.2.9-10+lenny8
	apache2-mpm-prefork	2.2.9-10+lenny8
	apache2-utils	2.2.9-10+lenny8
	apache2-utils	2.2.9-10+lenny8
	libapache2-svn	1.5.1dfsg1-5
	libapache2-mod-auth-mysql	4.3.9-11
	libapache2-mod-chroot	0.5-7
	libapache2-mod-perl2	2.0.4-5+lenny1
	libapache2-mod-php5	5.2.6.dfsg.1-1+lenny9
SVN (code management)	libsvn-dev	1.5.1dfsg1-5
	libsvn-perl	1.5.1dfsg1-5
	libsvn1	1.5.1dfsg1-5
Social network	elgg	1.7.11 version 2011052801
Bug tracker	mantis	V1.2.4
TV portal	clipbucket	2.0.91
e-education	moodle	09/01/11

*Table 3: Main components of the VM content*

VM Dev	Components	Version
Web server	apache2	2.2.9-10+lenny9
	apache2-mpm-worker	2.2.9-10+lenny9
	apache2-suexec	2.2.9-10+lenny9
	apache2-utils	2.2.9-10+lenny9
	apache2.2-common	2.2.9-10+lenny9

PHP	php5	5.2.6.dfsg.1-1+lenny10
	php5-mysql	5.2.6.dfsg.1-1+lenny10
Database client	mysql-client	5.0.51a-24+lenny5
	mysql-client-5.0	5.0.51a-24+lenny5
	mysql-common	5.0.51a-24+lenny5
Ffmpeg	ffmpeg	3:20080706-0.3lenny2

Table 4: main components of the VM Dev

VM Media	Components	Version
Media server	asterisk	1.6.2.8
	libasterisk-agi-perl	0.10-2
	Adhearsion	V1.1.1
VXML	Opencvxi	v3.4
	Voiceglue	0.12
	Phoneglue	0.10
Webradio	Icecast2	2.3.2-2
	MPD	0.13.2-3lenny1
	ices2	2.0.1-8
RTP proxy	rtpproxy	v1.1-2
J2EE	Mobicents/jboss	1.3/5.1.0.GA
ASR (vocal recognition)	Julius	V4.1.5
TTS	Festival	1.96

Table 5: main components of the VM Media

VM Routing	Components	Version
SIP proxy	OpenSIPS	1.6.2-1
HTTP proxy	Squid	2.7.STABLE3-4.1lenny1

	Apache2	2.2.9-10+lenny7
SMS proxy	Kannel	V1.4.1

Table 6: Main components of the VM Routing

The flows between the different VMs can be described as follow

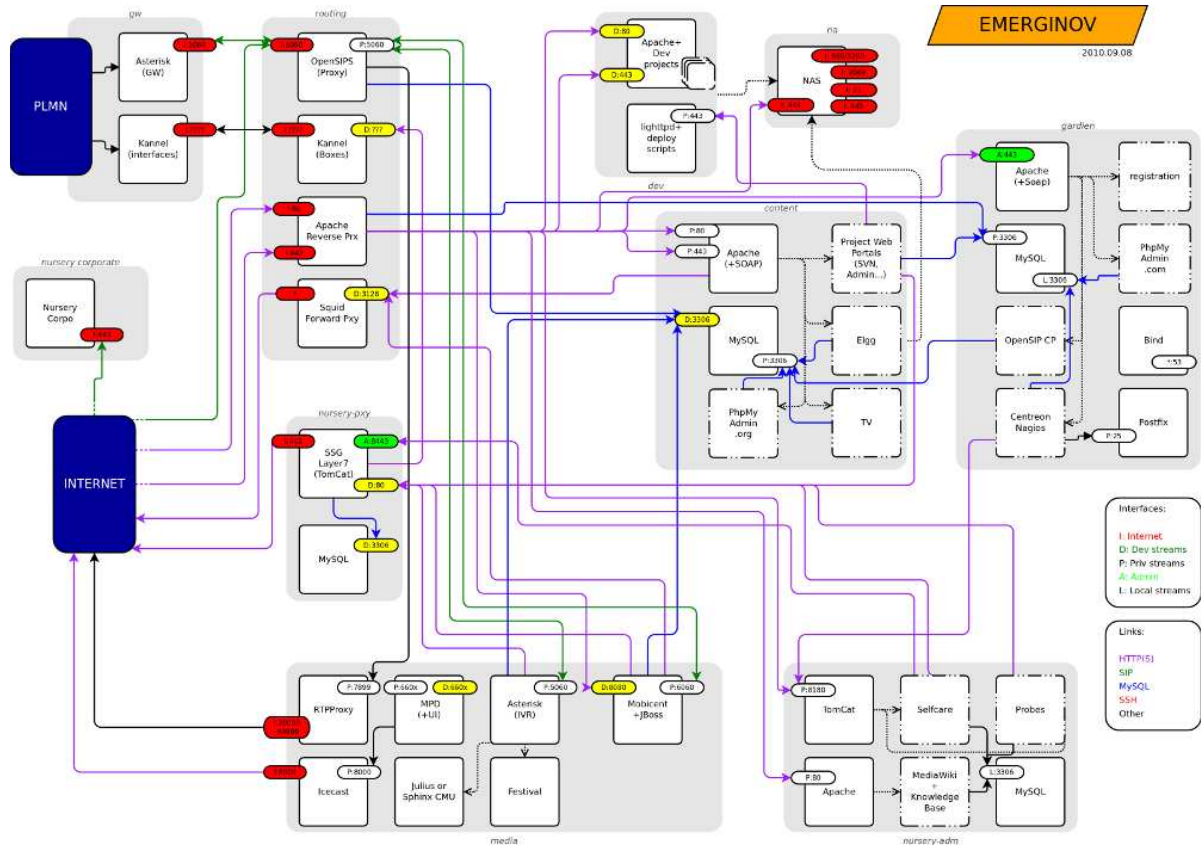

Illustration 7: Emerginov overall architecture

## 9 New Voices generic features

### 9.1 Platform adaptations for VOICES

There are 2 types of adaptations: the infrastructure and the applicative features.

#### 9.1.1. New infrastructure

##### Core platform and gateway in Senegal

A core platform was necessary. It was possible to use the French instance of the Emerginov platform. However it was decided to install such infrastructure in Senegal in order to be as close as possible from the field to reduce transmission and international interconnections and thus improve the end-to-end quality of service.

Sonatel, the incumbent operator in Senegal, was able to host and manage such infrastructure. It was also a way to involve local resources and ensure a long-term support as the infrastructure shall remain as an innovation infrastructure for West Africa.

The French infrastructure can be used for backup if necessary.

A local gateway is also necessary to provide local connectivity in Mali, for WP5 pilot. As mentioned in the Emerginov architecture section, we distinguish the core platform and the gateways. The gateways are light infrastructures bridging local mobile network (GSM, SMS) and the IP networks. Several gateways can be connected to one core platform in order to save maintenance and support costs.

##### GW in Mali

The gateway in Mali is based on the same architecture as the other gateways. The PSTN/SIP (vocal part) is realized via a Digium card associated to Asterisk software and connected to a T2 of Orange Mali. The SMS part is performed thanks to a Kannel SMS gateway directly connected to the SMSC of Orange Mali in one side and the SMS API of the nursery on the other side. So the developers will be able to send and receive SMS locally in Mali.

#### 9.1.2. New features

##### VXML

VoiceXML (VXML) is the W3C's standard XML format for specifying interactive voice dialogues between a human and a computer. It allows voice applications to be developed and deployed in an analogous way to HTML for visual applications. Just as HTML documents are interpreted by a visual web browser, VoiceXML documents are interpreted by a voice browser. A common architecture is to deploy banks of voice browsers attached to the Public Switched Telephone Network (PSTN) to allow users to interact with voice applications over the telephone.

VXML was therefore the natural technology to develop vocal services unlike proprietary solution of open source components. Moreover, as a standard, VXML will be part of the training defined in the WP6.

An VXML engine was thus required for the project. Several options were possible : Orange Media server, Voxeo, voiceglue. The only free and open source implementation is voiceglue. It was thus decided to study it and integrate it on the platform.

Through the SSML\_passthrough option of Voiceglue, it was possible to replace the default SSML interpreter (Flint) by Baratinoo, the Orange SSML one enabling the future inclusion of new languages such as Wolof and Bambara in the context of Voices.

### TTS

As mentioned in the previous section, the Text-To-Speech function is realized through the Baratinoo API. Baratinoo is an Orange proprietary solution providing high quality Text-To-Speech. Two new voices will be possible: one in Bambara (Mali) and one in Wolof (Senegal).

In TTS solution we may have several voices (male, female, particular accent,..) for one language. In the context of Voices, 1 voice will be developed in Bambara and 1 in Wolof. The voice in Wolof has been released as “alpha” voice in the nursery beginning of September, it is called \vox{fati}. See WP3 documents for details.

For the project, thanks to the media collected in the VOICES project (linguistic resources, vocal segments), it shall be possible to create such languages on other TTS solution, independently from Baratinoo. Voiceglue will allow the usage of any TTS solution.

Please note that the TTS open source solution festival is also available on the Emerginov platform. This solution can be used as an open source runtime.

### ASR

Julius is the runtime environment for ASR in Emerginov. Work performed in WP3 shall be integrated in order to allow vocal recognition Bambara.

### Media library/DAM (Digital Asset Management)

By default Emerginov integrates a TV portal and several web applications dealing with content (e-ducation based on Moodle, social network based on elgg) but no real digital library. That is why the media library from CSR4 called notreDAM has been integrated. An additional web portal and an API shall be developed in order to offer to



end user an easy way to contribute to the digital library of media segments under creative common license.

The need for a digital asset management system has been identified at the origin of the project and it is integrated in the platform through notreDAM.

### Crowd sourcing framework

A crowd sourcing solution has been identified in order to simplify the collection of vocal segments to be used by WP3. It shall be integrated with the digital asset management system.

## 9.2 Generic features and Emerginov

In the following section we will reconsider the requirements and precise how they will be fulfilled through the Emerginov platform.

Feature	Emerginov
flexibility (R.7.1)	<p>The choice of mature free software components provides de-facto documented components and interfaces.</p> <p>The use of the nursery as an API shop to provide open access to useful API allows also a great flexibility all the more as no control is performed and any API can be replaced by another one if needed (Google, Ericsson APIs).</p>
reachability (R.7.2)	<p>The architecture of the platform allows a distribution of gateways connected to a single core. Each gateway is a local entry point for SMS and vocal services.</p> <p>Each gateway in Senegal and in Mali provides an access to the local SMSC and offers ~ 30 simultaneous voice channel. These channels are shared with other projects but could be scaled if necessary by the addition of additional Telecom capabilities (T2)</p>
Accessibility (R.7.3)	<p>The vocal technologies provided through the API (TTS and ASR) include vernacular languages. Therefore illiterate people shall be able to interact with the platform through a vocal kiosk in native languages.</p>
Openness and Re-usability (R.7.4)	<p>The original concept of the platform integrates these two notions. The platform is open assuming that the developers are authenticated on the platform (see section developing with the platform). The APIs are available as well as the Web and Telecom resources. The choice of free software provides an easy access to source code in order to encourage reuse of code and build in fine digital reference libraries of micro-services.</p> <p>The USB key, toolbox containing all the major components of the platform ease the developments even in offline mode.</p> <p>The choice of creative common for any content used on the platform is also a concrete example of the wish to keep as open as possible assuming that the security criteria (authentication and architectural choices) are met.</p>
Long-term sustainability (R.7.5)	<p>One more time the choice of mature free software is a guarantee of long term sustainability</p>

	has the developments will not depend of industrial products whose roadmap could be stopped. The implication of local resources – the platform is physically located in Senegal, the gateways in Senegal and Mali means that local team are involved in the supervision/maintenance of the project.
--	--

Table 7: Generic features

### 9.3 Functional features and Emerginov

Feature	Id	Emerginov
Fixed and mobile calls - Senegal	R.1.1	Use of an Asterisk PSTN/SIP Gateway in Senegal connected to the core solution Use of OpenSIPS as internal SIP router
SMS - Senegal	R.1.2	SMS API in the nursery connected to an internal SMS gateway based on Kannel and connected to Sonatel SMSC
Internet - Senegal	R.1.3	Linux/Apache2/MySQL/PHP available for any developers. The creation of a project triggers the automatic creation of internet resources
Fixed and mobile calls - Mali	R.1.4	Use of an Asterisk PSTN/SIP Gateway in Mali connected to the core solution in Senegal.
SMS - Mali	R.1.5	SMS Gateway in Mali connected to local SMSC in one side and SMSbox in the core solution in Senegal
Internet - Mali	R.1.6	Idem R1.3 – not specific to Mali
Service execution	R.2.1	Media services are executed in the core platform on Asterisk/Voiceglue APIs are executed in back office where APIs are hosted HTTP based on Linux/Apache2/MySQL/PHP with possibility to define cron jobs for programmed tasks.
File hosting	R.2.2	Files are hosted on the core platform in a Subversion (SVN)
Database	R.2.3	1 MySQL database available per project. Credentials are automatically provided by mail at project creation.
IVR	R.3.1	Asterisk + Voiceglue
ASR	R.3.2	Julius but specific lexicon must be created
TTS	R.3.3	Baratinoo through an API in the nursery
Developers needs	R.4.1	USB key, developer guide (described in next sections)
Administration needs	R.5.1	Integrated in Emerginov platform through a dedicated portal <a href="https://admin.emergino.orange.sn">https://admin.emergino.orange.sn</a> managed by Sonatel multimedia
Mobile Applications	R.6.1	Use of the open source widget SDK (out of Emerginov platform), see <a href="https://elgg.emerginov.org/pg/groups/434/orange-widgets/">https://elgg.emerginov.org/pg/groups/434/orange-widgets/</a>

*Table 8: Functional features*

## 10 Platform planning

The platform used for VOICES is located in Sonatel grand Dakar premises in Senegal and hosted by Sonatel multimedia.

The planning may be described as follow:

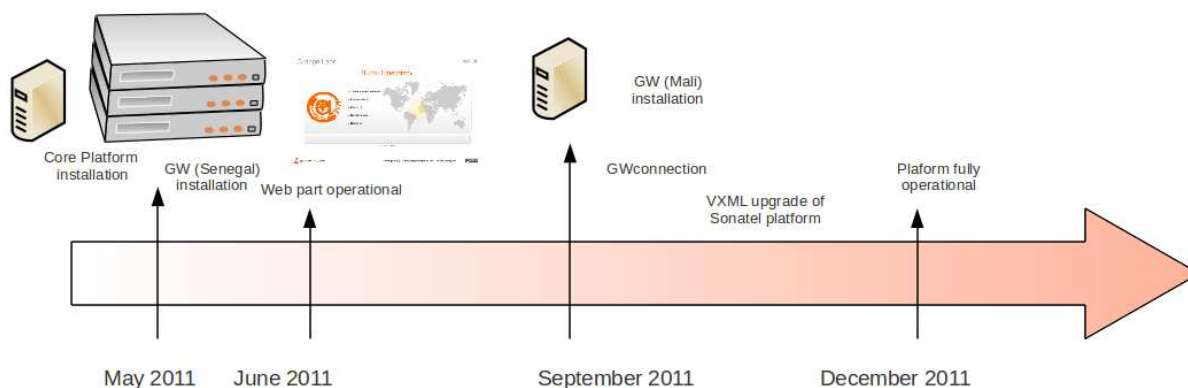

Illustration 8: Platform planning

The main milestones are

Milestone	Date planned	Status	Comments
French backup platform ready for training and testing	04/01/11	Done	Possible to start developing micro services (WP4 and WP5). The export of the micro services from the French backup platform could be easily performed through SVN export and reconfiguration of micro-services application.
Installation of the core platform in Dakar	May 2011	Done	Web site <a href="http://www.emerginov.orange.sn">www.emerginov.orange.sn</a> available VoIP issues due to firewall policy within Sonatel
Installation of the GW for Senegal	May 2011 October 2011	Done	GW installed and provided to Sonatel but not connected – wait for internal authorization. Interconnection expected for October
training of Sonatel Multimedia on administration	July 2011	Done	Training for the admin and the developers of Sonatel and Sonatel Multimedia

VOICES – N° 269954

[www.mvoices.eu](http://www.mvoices.eu)

Training of the VOICES developers	10/01/11		Contacts with WP6, credentials on existing Emerginov training materials for inputs of training sessions.
installation of the GW in Mali	September 2011	Done	PSTN and SMS connections possible from Mali
Integration of WP3 resources	From September 2011	Done	Wolof voice \vo{x}{fati} in alpha stage
Upgrade of the VXML module for the platform in Senegal	September 2011		Tests successful on reference platform. Remote upgrade to be performed on the platform to provide VXML capabilities and install the adhearsion layer
Interconnection tests	October 2011		Tests with SMS and Voice Gateways on core platform in Senegal

Since April 2011, it is possible to use the French backup platform in order to start developing the micro services (WP4, WP5) and work on the integration of vocal resources (WP3). Routable phone number as well as free French SMS can be used.

## 11 Developing on the Emerginov platform

This chapter does not aim to provide a full user guide. Such document is available on-line on the public wiki of the platform. You may have further information here: [https://developers.emerginov.org/wiki/index.php/Emerginov\\_User\\_Guide](https://developers.emerginov.org/wiki/index.php/Emerginov_User_Guide).

However we will provide the development cycle applicable to the different use cases described above. The development can be defined in different steps:

- Get an Emerginov account on the platform
- Log on your developer personal account
- Use the project creation form to create a project (= a use case). Do not forget to ask for a database in the form and for a PSTN routable number (even if the PSTN routable number is not automatically created unlike the database due to the management of such resources)
- Once the project is created log on the nursery and subscribe to the API needed by the use case
- SMS originating
- SMS terminating
- Text-To-Speech
- Code your use case and upload your code through the SVN
- Deploy your code via the web interface
- Test your service

### 11.1 Emerginov account

There are 2 ways to get an Emerginov account. You may create such account automatically if you have an Emerginov USB key at first connection of the USB key or you can ask the administrator of the platform to create an account. As there are 3 platforms up&running it is important to be on the right one, i.e. the platform hosted in Senegal.



*Illustration 9: Emerginov  
USB Key*

Booting on the USB key, your location will be asked. Wherever you are you shall precise a country in west Africa to create an account on the platform in Senegal.

The address of the administrator is [admin@emerginov.orange.sn](mailto:admin@emerginov.orange.sn)

You shall receive an email with all your credentials. These credentials are mandatory to access most of the features of the platforms especially the SVN, the APIs and the Telecom resources.

## 11.2 Personal account

Once you have your credentials you may log to your personal account.

From [www.emerginov.orange.sn](http://www.emerginov.orange.sn) click on the link “personal account”. The following page shall be displayed:

morgan.richomme - logout

### Personal account

**My Projects :**

Select a project you want to participate :

Select a project you want to be removed :

Choose a project :

**esmt\_wolof members :**

Username	Email address
arnaud.morin	arnaud1.morin@orange-ftgroup.com
james.tamgno	tamgno@esmt.sn
medoune.kane	medoune.kane@orange-sonatel.com
morgan.richomme	morgan.richomme@orange-ftgroup.com
thierry.bocher	tbocher.ext@orange-ftgroup.com
thomas.aristide	aristogrambel@yahoo.fr
uniel.elingui	elinguiuriel@yahoo.fr

**esmt\_wolof informations :**

**Tags :**

Change license : "Apache 2.0" ->

Project status : "deployed"

Project website : [http://projects.emerginov.orange.sn/esmt\\_wolof](http://projects.emerginov.orange.sn/esmt_wolof)

Project sources : [https://svn.emerginov.orange.sn/listing.php?repname=esmt\\_wolof](https://svn.emerginov.orange.sn/listing.php?repname=esmt_wolof)

Illustration 10: Personal account

A new web page shall be displayed. This page can be divided into 3 parts:

- My Projects
- New Project
- My account

### 11.3 Create a new project

On the personal account, there is a section dedicated to project creation.

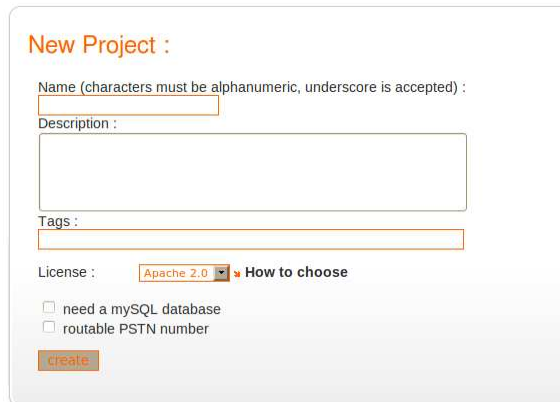

**New Project :**

Name (characters must be alphanumeric, underscore is accepted) :

Description :

Tags :

License :  [How to choose](#)

need a MySQL database  
 routable PSTN number

*Illustration 11: New project menu in personal account*

You shall

- describe the project
- add tags (they will appear in the cloud of tags on the public portal)
- select the licence (by default Apache 2.0 or GNU GPL v2)
- ask for a MySQL database
- ask for a PSTN routable number so your application could be reached from any mobile devices.

The creation will be effective once the Emerginov admin validated the demand.

### 11.4 Subscribe to APIs

Log on the nursery (same credentials); all the projects you are working in will be displayed.

Click on the Enabler's store corresponding to your project.





Bienvenue Morgan1912 morgan déconnexion

### Orange Nursery : mes projets

- Liste de projets**  
mes projets
- Mon profil**  
modifier mon profil  
mon mot de passe

Cliquez sur le nom du projet pour modifier les informations de ce projet. Pour en éditer ou consulter les souscriptions cliquez sur "Enabler's Store".

Nom	Début du projet	Fin du projet	Etat	Action
kisatoo	31/3/2011	2/12/2011	✓	Enabler's Store
codecamp_poil	31/3/2011	2/12/2011	✓	Enabler's Store
trafficwatch	31/3/2011	2/12/2011	✓	Enabler's Store
simple_SOAP_sample	31/3/2011	2/12/2011	✓	Enabler's Store
weight_survey	31/3/2011	2/12/2011	✓	Enabler's Store
test_adhearsion	15/6/2011	16/9/2011	✓	Enabler's Store
Health_Peul	24/6/2011	25/9/2011	✓	Enabler's Store
AnnuaireCI	23/8/2011	24/11/2011	✓	Enabler's Store
CI-Meteo	23/8/2011	24/11/2011	✓	Enabler's Store

Illustration 12:

Nursery web interface

You will see on the left column the APIs you already subscribed to, and in the right column the APIs you can subscribe. According to your use case (see previous chapter) select the APIs you need.



Bienvenue Morgan1912 morgan déconnexion

### Orange Nursery : Souscriptions dans le projet Health\_Peul

[Retour >>](#)

- Liste de projets**  
mes projets
- Mon profil**  
modifier mon profil  
mon mot de passe

Cliquez sur "Souscrire" dans la colonne "API Disponibles" pour accéder au formulaire d'inscription. La colonne "Mes API" vous permet de suivre et gérer vos souscriptions.

Mes API	API Disponibles
SMSender-REST <a href="#">Résilier</a> <a href="#">Modifier la demande</a>	Baralnoo <a href="#">Souscrire</a> Device Capabilities Enabler <a href="#">Souscrire</a> SMS Group <a href="#">Souscrire</a> sms-mo <a href="#">Souscrire</a> SMSender using SOAP <a href="#">Souscrire</a>

Illustration 13: API selection in Nursery

## 11.5 Code and upload the code

Coding can be done off-line but code shall be uploaded using SVN. The code must be on the SVN prior to any deployment. It is also mandatory to select a Free license to deploy your service.

Further information on SVN may be retrieved in the user guide (see [https://developers.emerginov.org/wiki/index.php/Emerginov\\_User\\_Guide#Source\\_code](https://developers.emerginov.org/wiki/index.php/Emerginov_User_Guide#Source_code)).

A SVN web interface is also available <https://svn.emerginov.orange.sn>.

## 11.6 Deploy the code

Deploying the code can be performed from the personal account web page.

Select your project then click on deploy or redeploy. A message shall be displayed on the top of page saying that the deployment has been successful.

emerge - voices  
arnaud.morin - logou

### Personal account

**My Projects :**

Select a project you want to participate :

Select a project you want to be removed :

Choose a project :  Project name

**usbkey members :**

Username	Email address
arnaud.morin	arnaud1.morin@orange-ftgroup.com
christophe.sauthier	christophe.sauthier@objectif-libre.com
max.sehouba	max@trstech.net

**usbkey informations :**

Tags :

Change license : "Apache 2.0" ->   [How to choose](#)

Project status : "hidden"  Web SVN link

Project sources : <https://svn.emerginov.org/listing.php?repname=usbkey>

License selector

Deploy button

*Illustration 14: Deploy from the personal account web page*

## 11.7 Test

Once deployed your application shall be active on the lived network.

The web site shall be on

[http://projects.emerginov.orange.sn/<the\\_name\\_of\\_your\\_project>](http://projects.emerginov.orange.sn/<the_name_of_your_project>)

The SMS bearer is automatically active once the APIs have been subscribed and properly configured.

The vocal service is automatically deployed. The extension can be called from any VoIP client registered under the domain [emerginov.orange.sn](http://emerginov.orange.sn). The name of the extension is mentioned in the SVN under the trunk/asterisk/config and is usually the project name in capital letter (e.g. NAME\_OF\_THE\_PROJECT).

VOICES – N° 269954

[www.mvoices.eu](http://www.mvoices.eu)

However the access from GSM world requires a manual operation from the admin. He/she shall attribute the routable PSTN number to this service performing a mapping between the extension name and a real routable number.

It is highly recommended to test the service locally. It is possible on the USB key where VoIP clients, asterisk media server and the PHP/Apache/MySQL components are available.

## 12 CONCLUSION

One of the main VOICES objectives is to deliver a toolbox for the development of voice services. Due to its capabilities, the Emerginov platform was selected. In order to allow the completion of the VOICES scenarios the platform needed to be extended, so it can fulfil the technical requirements derived from the defined technical needs.

This Deliverable has described the selected platform and the modus operandi for its configuration, administration and components integration. It also detailed how the use cases could be achieved thanks to an enhanced version of the platform. All the functionalities required by WP3, WP4, WP5 and WP6 have been identified and implemented.

The backup platform is available for developing and testing.

The gateway in Mali is available since September 2011 and connected to the backup platform until the installation is finalized in Senegal. It is however possible to test vocal services as well as SMS based service in Mali.

The core platform in Senegal ([www.emerginov.orange.sn](http://www.emerginov.orange.sn)) is up&running but the gateway is not connected yet.

The target platform is expected to be 100% operational for WP4/WP5 first deployment, and WP6 training by the end of the year, inline with the original schedule.

**13 APPENDIX-A: USE CASE VERSUS EMERGINOV****13.1 Use case #1: m-Health (WP4)**

The requirements may be summarized in the tables below.

Use case	Requirements	ID	Impact on Emerginov
#1 Analysis result collection	mobile application	R4.1.1	Development of a mobile widget – out of Emerginov scope
	mobile/fixe originated calls	R4.1.2	Use the Voice Gateway of Emerginov for incoming and outgoing calls 1 routable number shall be attributed for incoming calls. This call will be routed (VM routing) to the media server (VM media)
	interactive voice responder	R4.1.3	The IVR will be realized through VXML menu on top of Asterisk media server. The VXML will be store in vxml page stored on the dedicated web hosting space. The IVR will make use of DTMF (no ASR) for user inputs and French TTS for voice outputs.
	mobile originated SMS	R4.1.4	The SMS originating API available on the nursery will allow this action. A special code shall be defined for the service
	platform originated SMS	R4.1.5	The SMS terminating API can be used to send SMS from the platform.
	Database	R4.1.6	The service shall be created with the option need a MySQL database. A dedicated database will be automatically created for the service (VM content)
	Text To Speech fonction	R4.1.7	The TTS function is fulfilled through an API available in Emerginov Nursery. This component also known as Baratinoo allows high quality TTS using several voices in different languages (French, English, Spanish, Arabic, Wolof, Bambara)
#2 Quiz	web interface	R4.2.1	The creation of a project in Emerginov triggers automatically a web hosting. Therefore the web interface shall be displayed under projects.emerginov.orange.sn/<thename_of_the_project>
	database	R4.2.2	See R4.1.6
	platform originated SMS	R4.2.3	See R4.2.4, need a specific code (e.g. quiz)
	mobile/fixe originated calls	R4.2.4	See R4.1.2, need a specific routable number
	interactive voice responder	R4.2.5	See R4.1.3
	Text To Speech fonction	R4.2.6	See. R4.1.7

# 3 Information letter	web interface	R4.3.1	See R4.2.1
	database	R4.3.2	See R4.1.6
	platform originated SMS	R4.3.3	See R4.2.3, need a specific code (e.g. letter)
	platform originated calls	R4.3.4	Use of the high level API on top of adhearsion framework available on the Media platform
	mobile/fixe originated calls	R4.3.5	See R4.1.2
	interactive voice responder	R4.3.6	See R4.1.3
	Text To Speech function	R4.3.7	See R4.1.7

Table 9: WP4 requirements

### 13.2 Use case #2: m-Agri (WP5)

The requirements may be summarized in the tables below.

Use case	Requirements	ID	Impact on Emerginov
#1 market information system	web interface	R5.1.1	See R4.2.1
	database	R5.1.2	See R4.1.6
	Text To Speech function	R5.1.3	The TTS function is fulfilled through an API available in Emerginov Nursery. This component also known as Baratinoo allows high quality TTS using several voices in different languages (French, English, Spanish, Arabic, Wolof, Bambara)
	interactive voice responder	R5.1.4	See R4.1.3 + The IVR will make use of both DTMF and ASR for user inputs and TTS for voice outputs. The interaction language, French or Bambara, will be choose by the user.
	massive SMS campaign	R5.1.5	See R4.1.5, the platform is not a production platform meaning that the SMS are free but under quota to avoid spamming or misuse. For this use case the threshold shall be modified to allow a higher quota.
#2 M-Event Organizer for Sahel Eco	web interface	R5.2.1	See R4.2.1
	database	R5.2.2	See R4.1.6
	Text To Speech function	R5.2.3	See R5.1.3
	platform originated calls	R5.2.4	See R4.3.4
	interactive voice responder	R5.2.5	See R4.1.3

Table 10: WP5 requirements

## 14 REFERENCES

- [1]: First iteration of High Level Architecture, VOICES WP5 Deliverable D1.5 - author D.Blaissoneau
- [2]: VOICES: VOIce-based Community-cEntric mobile Services for social development, S.Boyera, v1.5, April 13,2010

### Links

Apache.org: <http://apache.org/>

Asterisk: <http://www.asterisk.org/>

Debian: <http://www.debian.org/>

Emerginov developer guide: <https://developers.emerginov.org/wiki/index.php>

Emerginov main web site: <http://www.emerginov.orange.sn/>

Emerginov personal account: [http://www.emerginov.orange.sn/main\\_authen/selfcare.php](http://www.emerginov.orange.sn/main_authen/selfcare.php)

Emerginov SVN: <https://svn.emerginov.orange.sn/>

MySQL: <http://dev.mysql.com/>

Nursery: <https://nursery.emerginov.orange.sn/OrangeNursery/jsp/index.faces>

openVxi: <http://www.speech.cs.cmu.edu/openvxi/index.html>

PHP: <http://www.php.net/>

VoiceGlue (VXML): <http://www.voiceglue.org/>

Xen web site: <http://www.xen.org/>

W3C Voice Browser Working Group: <http://www.w3.org/Voice/>