

INFSO-ICT-248523 BeFEMTO

D7.2

D7.2 - Final report on the standardization and dissemination activities of the project

Contractual Date of Delivery to the CEC:	<i>M30</i>
Actual Date of Delivery to the CEC:	<i>M30</i>
Author(s):	<i>Emilio Mino Diaz, Stefan Schmid, Rocío García, Stefan Kaiser, Thierry Lestable, Stefan Brueck, Lorenza Giupponi, Andrea Garavaglia, Mirosław Brzozowy, Frank Zdarsky</i>
Participant(s):	<i>NEC, TID, TTI, DOCOMO, SC, QC, PTC</i>
Workpackage:	<i>WP7: Standardization and Knowledge Dissemination</i>
Estimated person months:	<i>30 PM</i>
Security:	<i>PU</i>
Nature:	<i>R</i>
Version:	<i>1.0</i>
Total number of pages:	<i>92</i>

Abstract:

This document presents the project's standardization and dissemination plans and the results of these activities during the whole life of the BeFEMTO project.

Keyword list:

Dissemination, Standardization, Regulation, 3GPP, ETSI, Femto Forum, NGMN, IEEE, LTE, HeNB

Executive Summary

This deliverable summarizes the BeFEMTO activities related to standardization and dissemination for the whole life of the project.

Standardization activities have included the identification of the organizations and working groups to which BeFEMTO industrial partners will contribute with project results, based on the work packages and tasks activities. The results of the standardization effort have been 27 contributions to the Small Cell Forum, 3GPP and ETSI.

With respect to dissemination, a comprehensive list of dissemination channels (scientific publications, presentations in events, project website and even dissemination on social/technical networks) has been identified and used. Several publications in prestigious conferences, journals and magazines have been submitted and published, resulting in 59 papers, 10 journals and 2 Journals' special issues. Also, the organization of five (5) international workshops, during the IEEE VTC Spring 2011, ICT FuNEMS 2011, WCNC 2012, ICC 2012 and ICCCN 2012 conferences, five (5) panel sessions, and two (2) training schools have been carried out. Additionally, BeFEMTO partners have attended 23 international events such as Femto Forum, 3rd Japan-EU Symposium, etc, where the project goals, partners and scientific knowledge have been both presented and submitted.

In order to facilitate the tracking of BeFEMTO's plan and progress regarding standardization and dissemination activities, a common folder has been created on the BeFEMTO server, composed of dissemination and standardization plans and the corresponding registers for the effective results. This can be consulted by all partners to discover the dissemination and standardization channels that the various partners involved in the project are supporting.

Authors

Partner	Name	Phone / Fax / e-mail
Telefonica I+D		
	Emilio Mino	Phone: +34 91 3374428 Fax: + e-mail: emino@tid.es
	Luis Cucala	Phone: +34 913128804 Fax: + e-mail: lcucala@tid.es
TTI		
	Rocío García	Phone: +34 942 29 12 12 Fax: +34 942 27 01 39 e-mail: mrgarcia@ttinorte.es
NEC		
	Stefan Schmid	Phone: +49 6221 4342 154 Fax: +49 6221 4342 155 e-mail: stefan.schmid@neclab.eu
	Frank Zdarsky	Phone: +49 6221 4342 142 Fax: +49 6221 4342 5142 e-mail: frank.zdarsky@neclab.eu
DOCOMO		
	Wolfgang Kellerer	Phone: +49 89 56824 222 Fax: +49 89 56824 301 e-mail: kellerer@docomolab-euro.com
SC		
	Thierry Lestable	Phone: +33.6.88.35.55.22 e-mail: thierry.lestable@sagemcom.com
Qualcomm		
	Stefan Brueck	Phone: +49 911 54013270 Fax: + 49 911 54013190 e-mail: sbrueck@qualcomm.com
	Andrea Garavaglia	Phone: +49 911 54013530 Fax: + 49 911 54013190 e-mail: andreag@qualcomm.com
CTTC		
	Lorenza Giupponi	Phone: +34 93 6452922 Fax: + 34 93 6452901 e-mail: lorenza.giupponi@cttc.es
UNIS		
	Atta ul Quddus	Phone: +44 1483 683437 Fax: + 44 1483 686011 e-mail: a.quddus@surrey.ac.uk
PTC		
	Mirosław Brzozowy	Phone: +48 22 413 5881 Fax: + 48 22 413 6559 e-mail: Miroslaw.Brzozowy@t-mobile.pl

Table of Contents

1.	Introduction.....	8
2.	Standardization and Regulation.....	8
2.1	Benefits of interaction with standardization and regulation bodies	8
2.2	Femtocell standardization initiatives.....	9
2.2.1	Small Cell Forum (<i>formerly Femto Forum</i>).....	10
2.2.2	3GPP	11
2.2.3	NGMN	13
2.2.4	IEEE 802.16m (WiMAX Evolution)	13
2.2.5	ETSI.....	14
2.2.6	Summary of initially planned activities	15
2.3	Standardization and Regulation Action Plan	16
2.3.1	Small Cell Forum.....	16
2.3.2	3GPP.....	16
2.3.3	ETSI.....	17
2.3.4	ECO (European Communications Office)	17
2.4	Standardization and Regulation results	18
2.4.1	Femto Forum (<i>renamed to Small Cell Forum in February 2012</i>)	18
2.4.1.1	Enterprise Femto Architecture Proposal	19
2.4.1.2	Consistent Access to Enterprise Services	20
2.4.1.3	LIPA & SIPTO Mobility Support	21
2.4.1.4	Wi-Fi / Smallcell Mobility for Local/Enterprise Networks.....	21
2.4.1.5	LTE MAC Scheduler Interface Specification	21
2.4.1.6	LTE Network Monitor Mode Interface Specification	22
2.4.1.7	LTE eNB L1 API definition.....	22
2.4.2	3GPP.....	22
2.4.2.1	Downlink Interference Coordination Between eNodeB and Home eNodeB	22
2.4.2.2	Control Channel ICIC for Macro-Femto Deployments.....	22
2.4.2.3	SON, mobility enhancements and X2 interface for HeNB.....	24
2.4.2.4	Problem Scenarios and Proposed Solutions for Home BS Coexistence.....	26
2.4.2.5	R3#70BIS, Dynamic H(e)NB Switching by Means of a Low Power Radio Interface for Energy Savings and Interference Reduction	27
2.4.2.6	SA2#84, Standalone Local Gateway Architecture Variant (NEC).....	27
2.4.2.7	SA2#85, Standalone Local Gateway Architecture Variant (NEC).....	28
2.4.2.8	SA2 #86 Discussion paper for Standalone L-GW Architecture Option 2 (NEC) .	29
2.4.2.9	SA#2 Details of Standalone L-GW Architecture Option 2 (NEC).....	31
2.4.2.10	R3#72, Hybrid OAM and signalling based approach for E-UTRAN cell waking up from dormant mode.....	31
2.4.2.11	R3#73, Analysis of scenarios with energy saving cells and compensation cells. Carrier-based HetNet ICIC (QC)	32
2.4.2.12	Mobile Relays (QC)	33
2.4.3	ETSI.....	34
3.	Dissemination	35
3.1	Dissemination Action Plan.....	35
3.1.1	Conferences and Workshops.....	36
3.1.2	Journals and Magazines	36
3.1.3	Books	36
3.1.4	Presentations at events	36
3.1.5	Plenary meetings and annual meeting with project's Advisory Board.	36
3.1.6	Organization and sponsorship of events	36
3.1.6.1	International Workshops and panel sessions	36
3.1.6.2	Training School.....	36
3.1.7	BeFEMTO website	36
3.2	Dissemination Results.....	37

3.2.1	Conferences and Workshops.....	38
3.2.2	Journals and Magazines	43
3.2.3	Books	44
3.2.4	Presentations at events	46
3.2.5	Plenary meetings and annual meeting with project's Advisory Board	48
3.2.6	Organization and sponsorship of events	49
3.2.6.1	International Workshops and panel sessions	49
3.2.6.2	Training Schools	63
3.2.7	BeFEMTO website	69
3.2.7.1	Goal and Contents	69
3.2.7.2	Domain and Logo.....	69
3.2.7.3	Sitemap.....	70
3.2.7.4	External Links	72
3.2.7.5	Downloads.....	72
3.2.7.6	Statistics	75
3.2.8	Other dissemination channels	78
3.2.8.1	Post-graduate courses	78
3.2.8.2	Project Flyer	79
3.2.8.3	Wikipedia	79
3.2.8.4	YouTube Channel	79
3.2.8.5	Linkedin	81
3.2.8.6	Polish National Contact Point for Research Programmes of the EU.....	82
3.2.8.7	Other websites	82
3.2.8.8	Poster.....	82
4.	Management of Intellectual Property	83
4.1	LTE Patent status	83
4.2	BeFEMTO Follow-up.....	84
5.	Exploitation plans.....	85
5.1	Sagemcom (SC)	85
5.2	NEC	86
5.3	TID.....	86
5.4	DOCOMO.....	86
5.5	PTC.....	87
5.6	Qualcomm (QC).....	87
5.7	TTI	87
5.8	mimoOn	87
5.9	CTTC	88
5.10	CEA	88
5.11	University of Oulu (UOULU).....	88
5.12	University of Surrey (UNIS).....	88
6.	Conclusions	89
7.	References	90

List of Acronyms and Abbreviations

3G	3rd Generation
3GPP	3rd Generation Partnership Project
3GPP2	3rd Generation Partnership Project 2
4G	4 th Generation
AB	Advisory Board
ANFR	Agence Nationale des Fréquences
ARIB	Association of Radio Industries and Businesses
BeFEMTO	Broadband evolved FEMTO networks
BS	Base Station
BSCW	Basic Support for Cooperative Work
CCSA	China Communications Standards Association
CDMA	Code Division Multiple Access
CEPT	European Conference of Postal and Telecommunications Administrations
CENELEC	Comité Européen de Normalisation Electrotechnique
CEN	Comité Européen de Normalisation
CDF	Cumulative Distribution Function
CNR	Cognitive Radio Network
CoMP	Coordinated Multi Point
COPRAS	COoperation Platform for Research and Standards
CSG	Closed Subscriber Group
CT	Core Network and Terminals
DECT	Digital Enhanced Cordless Telecommunications
DL-HII	Downlink High Interference Indicator
EFN	Enterprise Femtocell Networks
EFGW	Enterprise Femtocell Gateway
EMC	Electromagnetic Compatibility
EPC	Evolved Packet Core
ERO	European Radio communications Office
ETSI	European Telecommunication Standard Institute
EU	European Union
FAP	Femto Access Point
FDD	Frequency Division Duplex
FP	Framework Programme
GERAN	GSM/EDGE Radio Access Network
GSM	Global System for Mobile communications
H(e)NB	Home (evolved) Node B
ICT	Information and Communications Technology
ICIC	Inter-Cell Interference Coordination
IEEE	Institute of Electrical and Electronics Engineers
IMT	International Mobile Telecommunications
IOT	Inter-Operability Test
IST	Information Society Technologies
KPI	Key Performance Indicator
LIPA	Local IP Access
LTE	Long Term Evolution
M2M	Machine-to-Machine
MBSFN	Multimedia Broadcast Single Frequency Network
MCD	Media Content Distribution
MNO	Mobile Network Operator
MRO	Mobility Robustness Optimization

MS	Mobile Station
NGMN	Next Generation Mobile Networks
OAM	Operation And Maintenance
OfCOM	Independent regulator and competition authority for the UK communications industries
OFDMA	Orthogonal Frequency Division Multiple Access
PCFICH	Physical Control Format Indicator Channel
PCI	Physical Cell Identity
PDCCH	Physical Downlink Control Channel
PHICH	Physical Hybrid Automatic Repeat Request Indicator Channel
RAN	Radio Access Network
RRS	Reconfigurable Radio System
SA	Service and System Aspects
SDO	Standard Defining Organizations
SDR	Software Defined Radio
SEAMCAT	Spectrum Engineering Advanced Monte Carlo analysis Tool
SIPTO	Selected Internet IP Traffic Offload
SME	Small-Medium Enterprise
SON	Self-Organizing Network
TC	Technical Committee
TDD	Time Division duplex
TETRA	Terrestrial Trunked Radio
TGm	Task Group m
TR	Technical Report
TTA	Telecommunications Technology Association of Korea
TTC	The Telecommunication Technology Committee
WG	Work Group
UKE	Polish Office of Electronic Communications
WiFi	Wireless Fidelity
WiMAX	Worldwide Interoperability for Microwave Access
WP	Work Package

1. Introduction

This document summarises the activities carried out in the BeFEMTO project in two aspects: standardization (including regulation), and dissemination. The goal of this work package is to disseminate the project vision and results to different standardisation organizations, and also to the scientific community in the area of the wireless networks. The focus of this deliverable is to report on the planned activities and to provide a full account of the achieved results during the whole project lifetime.

2. Standardization and Regulation

This section summarizes the BeFEMTO project standardization activities during the project lifetime, including the standardization action plan and the results.

The project aimed to disseminate the BeFEMTO results to the most relevant standardization organizations through those partners that are actively involved in these organizations. Note that in this section we refer to both standardization and regulation when we talk about standardization.

The necessary documents for the standardization planning and tracking of the results (namely the standardization plan and standardization register) have been created on the BSCW server. The aim was to have a common place to track the plan and progress regarding the BeFEMTO standardization activities. The folder on the BSCW server includes the following documents:

- **How to use Standardization Register and Standardization Plan.doc:** This is a word document with detailed information on the procedure.
- **BeFEMTO Standardization Plan.xls:** This register has a list of places where BeFEMTO should be present, with two tabs for standardization and regulation. All the participants can upload or consult the foreseen dissemination intentions, with all necessary information (submission date, venue, contribution title and abstract, partners who will attend to an event, etc). This gives a global view of BeFEMTO standardization activities in the near future.
- **BeFEMTO Standardization Register.xls:** The goal of this register is to provide a list of the BeFEMTO standardization results, with the same tabs structure as the Standardization Plan. It is important to note that here a structured file name that should be used to upload the standardization contribution in the “Repository of Standardization Documents” is automatically generated. All partners will include their actual standardization contributions here.
- **Repository of Standardization Documents:** The folder with all BeFEMTO standardization contributions.

2.1 Benefits of interaction with standardization and regulation bodies

In order to achieve a noticeable impact, all research initiatives will require interactions with standardization organization or forums to reach real products and deployments. The most obvious mandatory standardization organization for BeFEMTO is the 3rd Generation Partnership Project (3GPP), with respect to the LTE-Advanced radio interface and Femtocell (Home eNodeB). Other standardization organization and forums also have an important influence in mobile communications, directly or through partnership with 3GPP. Among them, we can mention ETSI, NGMN and the Small Cell Forum. Also IEEE is an important organization to be monitored for related standards such as WiMAX (802.16) and WiFi (802.11).

In order to present the relevance of standardization, we recall what was written by COPRAS (Cooperation Platform for Research and Standards), an IST project under the 6th Framework Program, initiated by the three European standards bodies CEN, CENELEC and ETSI, together with the World Wide Web Consortium and the Open Group [1], and can be summarized as:

- Early access to specifications, prototypes and legislation

- Better understanding of standards (and their underlying design), trade-off and compromise during the development process, and the operating conditions and environments they are intended to serve
- Leverage the expertise of standards organizations in building consensus
- Development of relationships and contacts that may become additional technical resources
- Reducing commercial risks through lowering development costs (due to knowledge and experience sharing among a larger group of participants)
- Improved ability to identify future trends (due to research developing during the design of the standard)
- Increase technical staff experience by giving them the opportunity to work with leaders in the field and to witness standards development processes

2.2 Femtocell standardization initiatives

The findings of the BeFEMTO project have been done in the following areas:

- Improvements to the LTE-A radio access technology, and
- Architectural, functional and protocol enhancements for the newly defined deployment scenarios (i.e. relay and mobile femtocells and co-operative networked femtocells).

The BeFEMTO project has targeted to disseminate and present these findings in the appropriate standards bodies and working groups. The project has worked on ensuring a smooth system evolution path from today's femto technologies through the close dialogue with the relevant standardisation bodies. Close collaboration with standardisation groups has been done to help the project to get technical feedback and reach preliminary consensus that our ideas are the right way forward.

The two most important standardisation bodies for us have been:

- **3GPP** – where the actual standardisation of LTE-Advanced and Femto technologies is carried out, and
- **Small Cell Forum (former Femto Forum)** – where pre-standardisation discussions and coordination across the industry takes place

The initially planned contribution of BeFEMTO to 3GPP releases is illustrated in the following figure:

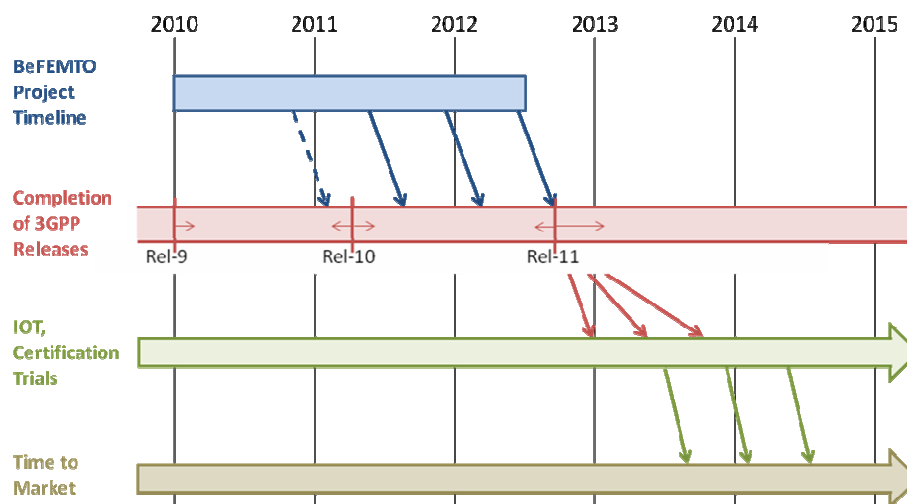

Figure 2-1: BeFEMTO time plan and 3GPP releases

Furthermore, through the BeFEMTO Advisory Board, the project also has aimed to ensure that the technological achievements feed into regulatory decisions and vice versa, where regulatory specifications drive BeFEMTO's scope of research and development.

The BeFEMTO project has contributed or participated in the following standardisation bodies and industry fora, addressing both mobile radio standards and network management standards:

2.2.1 Small Cell Forum (formerly Femto Forum)

The Small Cell Forum – an independent industry and operator association – aims to achieve global recognition of femto technologies as the de facto solution for mobile coverage in the home and to drive worldwide take-up of such technologies. In that respect, the forum targets to advance the development of femtocell products and services as the optimum technology for the provision of high-quality coverage and premium services within the residential and SME markets.

The work within the Small Cell Forum is structured according to the following four Work Groups:

- WG1:** The marketing & promotion group is looking at how the industry should best position femtocells within the industry and to the wider public, build use cases, agree common terminology and handle any potential concerns.
- WG2:** The radio & physical layer group is developing standardised RF interfaces, clarifying the various capability classes of femtocell and examining interactions with outdoor cells.
- WG3:** The network & interoperability group is promoting standardised requirements, architectures and interfaces for integrating femtocells into the network core and ensuring multi-vendor interoperability.
- WG4:** The regulatory group identifies regulatory benefits and potential issues pertaining to public policy in various strategic markets around the world and works with regulators to ensure a benign environment for rapid and efficient femtocell deployment.

The work carried out in WG2, WG3 and WG4 has been of particular interest for the technical work within BeFEMTO. The results of the project have been disseminated in those working groups.

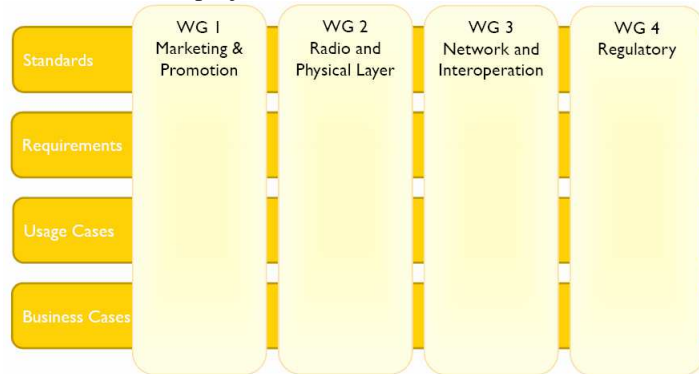

Figure 2-2: Femto Forum Working Group Structure

Table 2-1 Current hot topics being discussed in Small Cell Forum and indicates which topics are relevant for BeFEMTO:

Working Group	Current / hot topics	Related BeFEMTO
WG1	Business Models Use Cases	WP2
WG2	<ul style="list-style-type: none"> • Radio Aspects of Metro LTE deployment • Radio Aspects for Open Access • WiFi Co-existence • Advanced Interference Management • Location Verification and Synchronisation • Interference Management in Enterprise Deployments • Mobility Management for Enterprise • Transmit Power Control • Special Interest Group on LTE Femtocells 	WP3, WP4

WG3	<ul style="list-style-type: none"> • Enterprise Femto Requirements and Architecture • Local IP Access (LIPA) and Selected IP Traffic Offload (SIPTO) • Single site/multisite/mobility and service consistently • Public places Femto • IMS for enterprise or public • Enterprise OAM • Special Interest Group on Femtozone Services 	WP2, WP3, WP4, WP5
WG4	Regulation	WP4

Table 2-1: Small Cell Forum working groups

The work carried out as part of WG1 “marketing & promotion” is also of interest to the project (PTC participates in WG1), but no significant contributions from BeFEMTO have been done

The core of the BeFEMTO industrial partners, namely mimoOn, NEC, DOCOMO, Telefónica (through Telefónica O2 Europe), Qualcomm (QC) and Sagemcom (SC), are all members of the Femto Forum. In 2011 PTC joined also the forum as an observer.

2.2.2 3GPP

The Table 2-2 below lists all official Work Items identified within 3GPP LTE-A (Rel.10/11), and of interest to BeFEMTO objectives & investigations.

Rel.10	3GPP Work Items	Identifier (3GPP ID)	FP7 BeFEMTO VPs & Tasks potentially interested / Contributions																		
			VP2				VP3				VP4				VP5						
			T21	T22	T23	T24	T31	T32	T33	T41	T42	T43	T44	T51	T52	T53	T54				
	Extended Hic (ME) Features Local IP Access & Scheduled Internet IP Traffic Offload (LIPA SPTD) Support Broadband Forum Accesses Interworking	480053	X	X	X												X	X	X	X	
	Self-Optimization Self-Healing Networks (SON) - Energy Saving	460035 460036 460037	X		X	X	X	X	X	X	X	X	X	X	X	X					X
	Key Performance Indicators (KPI) for EPC Management of UE based network performance Measurements	470041 470042 470043				X	X				X		X								
	Carrier Aggregation for LTE Enhanced Downlink Multiple Antenna Transmission for LTE	460007 460008					X							X							
	Uplink Multiple Antenna Transmission for LTE	460009			X								X								
	Enhancements for LTE HMB and HMB Mobility Enhancements	460013 470005	X		X	X	X	X	X	X	X	X	X	X	X	X					
	enhanced Interference Management for Home NBs Enhanced ICIC for non CA based deployments of heterogeneous networks (HeNBs) for LTE	470006 470007				X	X	X	X	X	X	X	X	X	X	X					
	LTE TDD in 2.6GHz LTE Self-Optimizing Networks (SON) enhancements	470008 470011				X	X	X	X	X	X	X	X	X	X	X					
	Coordinated Multi-Point	470014											X								

Table 2-2: 3GPP LTE-A (Rel.10/11) Work Items of Interest to BeFEMTO

BeFEMTO main focus in standards has been in 3GPP (partnership between ARIB, CCSA, ETSI, FemtoForum, T1, TTA and TTC), as it is the body responsible for standardization of LTE as a 4G system (IMT-Advanced candidate). Beginning of 2009, 3GPP has published the first standard on femtocells (Rel.8), in cooperation with Small Cell Forum and the Broadband Forum (the latter with extensions to TR-069 and TR-196). The new femtocell standard, which applied to 3GPP Release 8 in the beginning, has now evolved into various work and study items currently being studied in Release 10/11.

BeFEMTO contributions have been done in the areas of LTE-Advanced, including Home (e)NodeBs and enterprise femtos, in the form of discussion papers or change requests and, where applicable, in the form of new study/work item proposals (e.g., “SON for cooperative H(e)NB networks”).

In this context, 3GPP Release 10/11 work in RAN groups (RAN1 to RAN4) and SA5 have been closely monitored. Some of the most relevant work areas are:

- SON (Self-Organizing Networks) management – SA5
- Enhanced ICIC (Inter-Cell Interference Control) for HetNets – RAN1/2/3/4
- HNB and HeNB Mobility Enhancements – RAN3
- LTE SON enhancements – RAN2/3/4
- CoMP (Coordinated Multi-Point) for LTE – RAN
- Others together with new study/work items

The core of the BeFEMTO industrial partners includes NEC, DOCOMO, Telefónica, QC, and SC, are members of 3GPP.

2.2.3 NGMN

The Next Generation Mobile Network (NGMN) operator alliance has been set-up to complement and support the work within standardisation bodies by providing a coherent view of what the operator community is going to require in the decade beyond 2010. This activity includes discussions on new network deployments efficiently integrating femtocells. For this purpose, NGMN and the Small Cell Forum agreed in 2008 to cooperate on how femtocells can benefit the architecture of a new generation of mobile broadband networks.

The activities of the NGMN alliance are relevant for the BeFEMTO project since NGMN is consolidating views of leading mobile operators on new network architectures including femtocell deployment. These views can be considered as potential requirements for future standardization activities and can give early indications of future trends to the BeFEMTO project.

Telefónica, NEC and DOCOMO are active members of NGMN and have been closely following the activities on future femtocell deployment.

2.2.4 IEEE 802.16m (WiMAX Evolution)

The Task Group m (TGM) is the working group defining the amendment to IEEE 802.16 targeting IMT-Advanced requirements. As such, TGM can be seen as a candidate technology to IMT-Advanced. Whilst mentioning IEEE 802.16m, we should of course bear in mind WiMAX Forum, since IEEE TGM only focus on PHY/MAC aspects, whilst Network oriented features, and certification are handled by the WiMAX Forum.

Even though BeFEMTO took the crystal decision to follow the LTE technological path initiated by 3GPP, and thus to actively contribute & influence the coming releases for LTE-A (Rel.10) and beyond (Rel.11), it has been worth to keep a close look onto the WiMAX path which is definitely the obvious concurrent to 3GPP LTE, whilst involving similar key technologies.

The WiMAX Evolution standard (802.16m) incorporates support for Femtocells (section 16.4 from IEEE P802.16m/D6), with what is called ‘Femto Advanced Base Station (BS)’ instead of Home eNodeB (HeNB) for 3GPP.

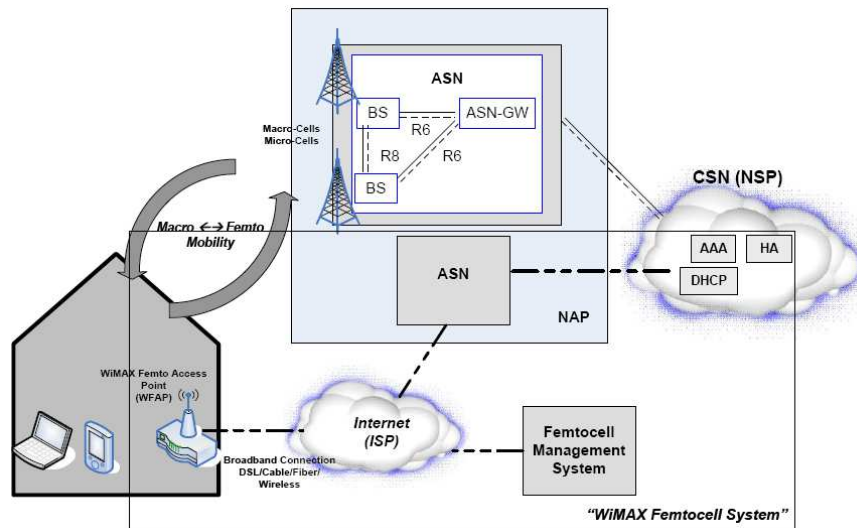

Figure 2-3: WiMAX Femtocell system

Lately, TD-LTE is attracting a lot of interest and many WiMAX vendors are migrating their products to TD-LTE – it is thus interesting to be capable of evaluating somehow the pros & cons of different but still quite similar technological paths.

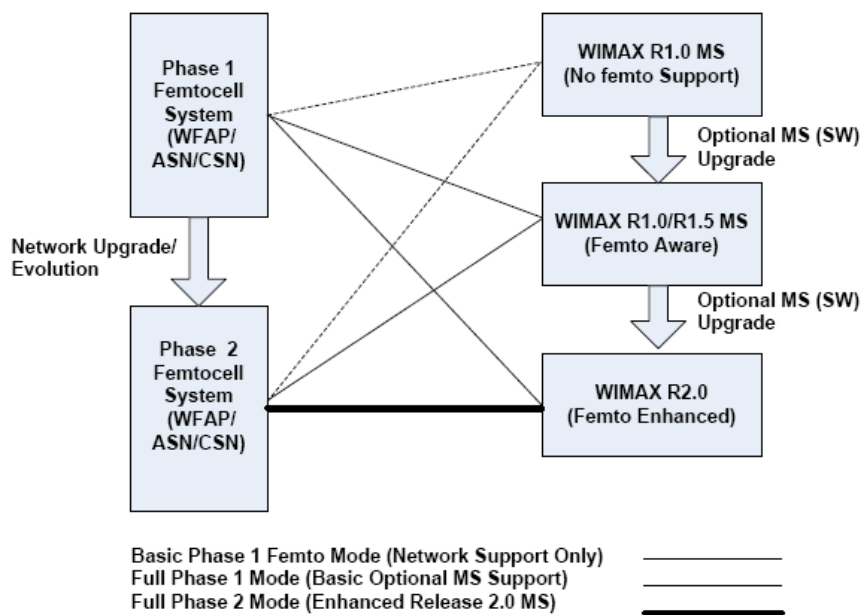

Figure 2-4: WiMAX Femtocell Deployment Strategy

This 802.16m related technology will thus has been monitored only (no active participation or contributions) by Sagemcom (WiMAX Forum member) for potential feature list & approaches comparisons.

2.2.5 ETSI

ETSI produces globally applicable standards for ICT (Information and Communications Technologies), including fixed, mobile, radio, converged, broadcast and internet technologies, recognized by the European Union (EU) as a European Standards Organization.

The technical work in ETSI is structured in Technical bodies that include Projects and Partnership Projects:

- Partnerships Projects include the cooperation with the 3GPP Technical Specification Groups (RAN, GERAN, CT and SA).
- ETSI currently has 27 active Technical Committees /Projects, covering a wide range of technical aspects including: mobile, satellite and terrestrial communications and communication systems (e.g. TETRA and DECT).

BeFEMTO relevant ETSI Technical Committees:

- TC RRS. Reconfigurable Radio Systems
- TC M2M. Machine to Machine Communications
- TC MCD. Media Content Distribution

Table 2-3 lists current topics being discussed in ETSI Technical Committees RRS and M2M:

Technical Committees	Item	Related BeFEMTO
TC RSS RSS 01. Spectrum sharing RSS02. SDR architecture and services RSS 03. Business and cost analysis	<p>RSS 01</p> <ul style="list-style-type: none"> • Architecture for spectrum sharing and coexistence between multiple Cognitive Radio Networks (CRN) • Operation as secondary systems in assigned/licensed frequency bands • Protection methods of primary/incumbent users <p>RSS 02</p> <ul style="list-style-type: none"> • Multiradio Interface for Software Defined Radio (SDR) Mobile Device Architecture and Services <p>RSS 03</p> <ul style="list-style-type: none"> • Business and cost considerations for RRS in Public Safety domain 	WP2, WP5
TC M2M	<ul style="list-style-type: none"> • Use Cases for eHealth, automotive, City automation and consumer electronic applications 	WP2

Table 2-3: ETSI RSS and M2M Technical Committees

The work carried out in TC RSS is of particular interest for the technical work within BeFEMTO related with Home eNB and software Defined Radio platforms, and the results of the project have been disseminated in that working group.

BeFEMTO partners who have attended to ETSI standardization committees are:

- Qualcomm.
- Sagemcom
- Telefonica - Technical Committee RSS 02

2.2.6 Summary of initially planned activities

Table 2-4 summarizes the initially planned standardization activities within the BeFEMTO project. The table lists on a per partner basis the activity level towards the different Standards Defining Organizations (SDOs) and Working Groups/Areas.

The following activity levels have been defined:

- Active contributor (A)
- Support and Monitoring (S&M)
- Other (O)

SDO	3GPP					FemtoForum				NGMN	IEEE	ETSI		ERO
Area Working Group	RAN 1-4/ LTEA	RAN 1-4/ HeNB	SA42 EHNBF	SA42 LIPA/ SIPTO	SA2 BBAI	WG1	WG2	WG3	Re search Initiative	Misc	.16 .11 .15	RSS	Regu lation	SEAM CAT TOOL
SC	A	A				A	A	S&M			S&M		S&M	A
NEC			A	A	A			S&M		S&M				
TID	S&M	S&M								S&M		A	S&M	
DOCOMO	A	A					S&M			O				
PTC	S&	S&											S&	
QC	A	A					S&M							
TTI	S&M	S&M												
CTTC	S&M /O	S&M /O							S&M/ O					

Table 2-4. Standardization Activity Matrix

2.3 Standardization and Regulation Action Plan

This section lists on a per SDO basis, the initial project plans to contribute to the various working group or activities

2.3.1 Small Cell Forum

Work Package / Task	Topic	WG	Partners
• WP3	• Contribution to LTE White papers	WG1	SC
• WP3 • WP4	• RADIO & PHY (interference mgmt. / UE battery life) • Contribution to LTE/OFDMA White papers	WG2	SC, DOCOMO, QC
• WP2, T2.1 “Use cases and Impact on Business Models”	• Market status, Femto deployment plans	WG1	PTC
• WP2, T2.3 “System Architecture” • WP5, T5.1 “Access control” + T5.3 “Mobility Management”	• Promote Networked Femto Requirements and Architecture • Local Mobility Management • Access to local services and traffic offload	WG3 - Architecture	NEC
• WP2, T2.2 “Requirements” + T2.3 “System architecture” • WP4, T4.2 “Multi-Cell RRM for Networked Femtocells” • WP5, T5.2 “Traffic Forwarding and Resource Sharing”	• Presentation of research results in academic sessions organized in the framework of FemtoForum research initiatives, in case these sessions are actually organized	Research initiative	CTTC

2.3.2 3GPP

Work Package / Task	Topic	WG	Work Items	Partners
• WP2, T2.1 “Use Cases” +	• Contribution to Enterprise Femtocell Rel-11 requirements	SA1	EHNBF + LIPA_SIPTO	NEC

T2.2 – “Requirements”			+ LIMONET	
<ul style="list-style-type: none"> WP2, T2.3 “System Architecture” + T5.3 – “Mobility Management” 	<ul style="list-style-type: none"> Architectural enhancements Local Mobility LIPA and SIPTO in Enterprise Femto Networks Backhaul over broadband and policy control / QoS 	SA2	EHNBF + LIPA_SIPTO + LIMONET + BBAI	NEC
<ul style="list-style-type: none"> WP2, T2.2 “Requirements” WP3, T3.1 “Next generation RF and Signal Processing” WP4, T4.1 “Self Organized Networks” 	<ul style="list-style-type: none"> HeNB RF requirements Carrier Aggregation for LTE RRM (Radio Resource Management) aspects Deployment scenarios / Co-existing studies BS RF requirements Enhanced Downlink Multiple Antenna Transmission for LTE Uplink Multiple Antenna Transmission for LTE Enhanced ICIC for non-CA based deployments of heterogeneous networks for LTE LTE Self Optimizing Networks (SON) enhancements 	RAN4	HeNB, LTE, LTE-A	TTI, SC, TID
<ul style="list-style-type: none"> WP3, T3.2 “Interference Management for Indoor Standalone Femtocells” + T3.3 “RRM for Standalone Femtocells” 	<ul style="list-style-type: none"> Interference coordination between eNB and HeNB 	RAN1	LTE-A + HeNB	DOCOMO, SC
<ul style="list-style-type: none"> WP4, T4.2 “Multi-Cell RRM for Networked Femtocells” + T4.3 “Integration and Optimization of SON Enabling Techniques” 	<ul style="list-style-type: none"> HeNB, SON, Relay Architecture Interference Coordination/Management (X2 interface) 	RAN3	HeNB + SON + Relay Architecture	SC, QC

2.3.3 ETSI

Work Package / Task	Topic	WG	Work Items	Partners
<ul style="list-style-type: none"> WP5, T5.2 	<ul style="list-style-type: none"> Development of the multi-radio femtonode concept, including Software Defined Radio and Cognitive radio techniques. Proposal for a new study in ETSI RSS 	RSS	Reconfigurable Radio System (SDR and CR)	TID

2.3.4 ECO (European Communications Office)

Work Package / Task	Topic	Work Items	Partners
<ul style="list-style-type: none"> WP2 WP3 WP4 	<ul style="list-style-type: none"> Providing Technical information to ECO in order to enhance the SEAMCAT tool with FEMTOCELL Technologies 	SEAMCAT Tool	SC

The European Radio Office, now renamed under European Communications Office (ECO), has developed jointly with the CEPT for several years a software-based (Java) simulation platform, named SEAMCAT (Spectrum Engineering Advanced Monte Carlo analysis Tool) for its own evaluations and co-existence studies (<http://www.ero.dk/seamcat>).

This platform has thus been upgraded step by step, with CDMA features, and lately with OFDMA features, in order to comply with the LTE air interface. Among other things, it should be noticed that this software is distributed free of charge (<http://www.seamcat.org/>).

The plan of BeFEMTO has been is to discuss with the SEAMCAT Working group chair, Jean-Philippe Kermaol, who is also member of our Advisory Board, how and to what extent BeFEMTO's Femtocell evaluation methodologies (WP3 and WP4), know-how and results could benefit the future development of this tool. Indeed, femtocells deployment are sure to become a critical interference and co-existence issue to be handled by CEPT Spectrum Engineering group and thus ECO.

SEAMCAT Workshops are organised by ECO along the year, and allow some external contributions from stakeholder concerning some dedicated technical topics. The Advisory Board meeting Kick-Off, organised during the last General Assembly (GA#3) meeting in December 2010 gave us the opportunity to have a clear progress status and workplan about the SEAMCAT developments, directly by Jean-Philippe Kermaol, together with identifying the contribution opportunities, and the right process to have those contributions addressed in the relevant committee.

2.4 Standardization and Regulation results

Standard/industry Alliance	Group	Contributions	Total	Reporting period 1	reporting period 2
Femto Forum	LTE-SIG	3	7	5	2
	WG3	4			
3GPP	RAN-1	2	19	6	13
	RAN-3	12			
	RAN-4	1			
	SA-2	4			
ETSI	RRS	1	1	1	0
Total		27	27	12	15

Table 2-5 Standardization contributions results

2.4.1 Femto Forum (*renamed to Small Cell Forum in February 2012*)

Two (2) contributions related to the BeFEMTO results on multi-femtocell networks (WP5) have been presented during the FemtoForum Meeting #14 in San Francisco on 28-30 September 2010. The title and the contents are as follows:

- Enterprise Femto Architecture Proposal (see section 2.4.1.1)
- Consistent Access to Enterprise Services (see section 2.4.1.2)

Furthermore, partners of BeFEMTO have been active in the elaboration on internal Femto Forum documents (October 2011), as follows:

- **LTE MAC Scheduler Interface Specification.** This document is the specification of the Femto Forum recommended API for LTE Femtocell Schedulers. Chaired by W. Mulder (mimoOn), participation from multiple FemtoForum members, baseline document contributed by mimoOn.
- **LTE Network Monitor Mode Interface Specification.** This document is the specification of the FemtoForum recommended API for the LTE Femtocell Network Monitor Mode (sniffer) function. Chaired by M.Palmowski (mimoOn), participation from multiple Femto Forum members, baseline document contributed by mimoOn.
- **LTE eNB L1 API definition.** This document is the specification of the Femto Forum recommended API for LTE eNB L1 (MAC-PHY API). Chaired by C. Sommerville (picoChip),

participation from mimoOn and multiple other Femto Forum members, baseline document contributed by picoChip & mimoOn.

Finally, at the first Small Cell Forum meeting in Taipei, Taiwan on 27-29 March 2012, BeFEMTO partners contributed on the following topics related to the work in WP5 on Femtocell Networks:

- LIPA & SIPTO Mobility Support (see section 2.4.1.3)
- Wi-Fi / Smallcell Mobility for Local/Enterprise Networks (see section 2.4.1.4)

2.4.1.1 Enterprise Femto Architecture Proposal

This contribution proposed the introduction of a new gateway/controller within a femtocell network that enables local mobility management, local routing, Local IP Access and Selected IP Traffic Offload, as well as optimized management for large networks through delegation.

The motivation for the enterprise femtocell gateway/controller is based on the results of the WP5 work on multi-cell femto networks. The entity is referred to as Local Femtocell Gateway (LFGW) in the BeFEMTO WP5 deliverables.

The use case and scenario study in WP5 reached the following conclusions: medium-to-large Enterprise Femtocell Networks (EFN) – like other types of femtocell networks – have the following properties:

- A multitude (tens or even hundreds) of Enterprise HeNBs constitute an EFN
 - The solution must be scalable
 - Management of large number of Enterprise HeNBs should be optimized
- Highly frequent intra-EFN handovers must be assumed
 - Optimizations for frequent handovers are desirable
- A significant portion of user traffic remains local (e.g. for local services)
 - Optimizations for local traffic handling are desirable
- All HeNBs of an EFN belong to the same administrative domain
 - Cooperation strategies among the Enterprise HeNBs can be leveraged to improve the overall performance
- Seamless access to Enterprise Services – independent of the user location – is desirable
 - Mobility aspects for LIPA need to be considered

As a consequence, the following features have been considered desirable for such EFNs:

- Low-cost scalability to large number of Enterprise FAPs
 - Minimize management overhead for adding many FAPs
 - Minimize signalling load due to frequent handover within EFN
 - Minimize user plane load among UEs attached to the same EFN
- Support for local mobility management
 - To hide inter Enterprise FAP handover from the mobile core
- Consistent access to Enterprise Services
 - From within the EFN and from the macro cellular network
 - Incl. service continuity while moving within the EFN and for hand-in/out
- Support for seamless traffic offload from within the EFN
 - Enable MNOs to offload selected traffic from the core network
 - Enable MNOs to activate local routing within the EFN
- Support for advanced management
 - Paradigm shift from management of a single HeNB to a whole EFN
 - Delegation strategies to support aggregated Enterprise FAP management from an MNO perspective can be utilized
 - Support of adequate SON features to ease management of large EFNs

In order to cope with these EFN requirements, WP5 developed the following architecture proposal for medium-to-large EFN. The key differentiator to the current femtocell architecture is the newly introduced Enterprise Femto Gateway (EFGW). Note that in the context of WP5 this is referred to as the Local Femto Gateway (LFGW) as the scope of the discussions in WP5 is not limited to EFNs.

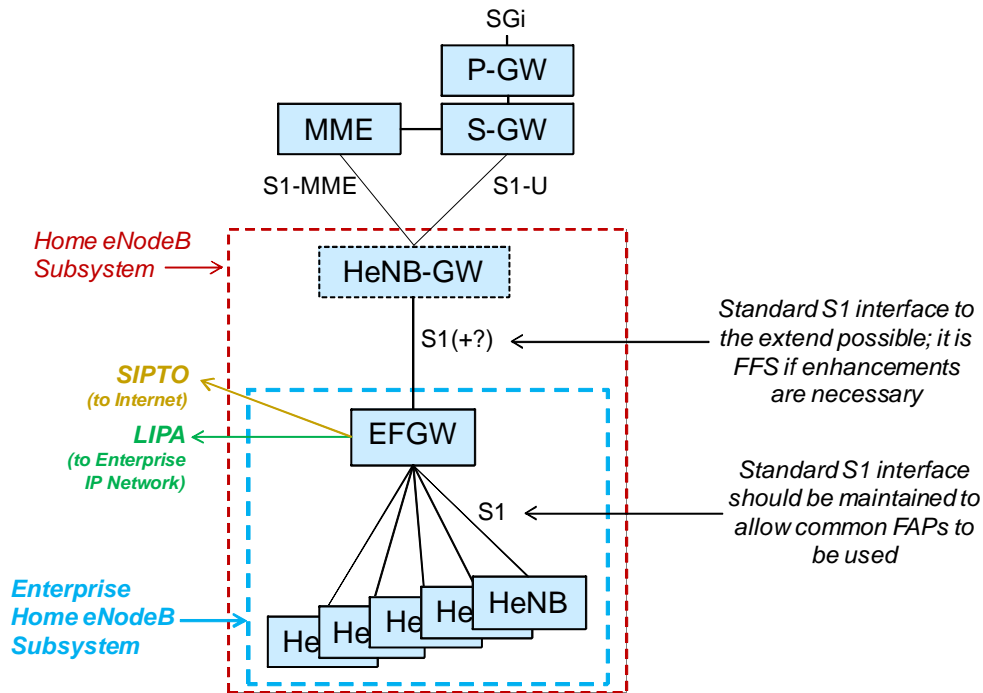

Figure 2-5: BeFEMTO Architecture proposal for medium-to-large size Enterprise Femtocell Networks (EFN)

The following figure shows further details of the newly proposed Enterprise Femto Gateway:

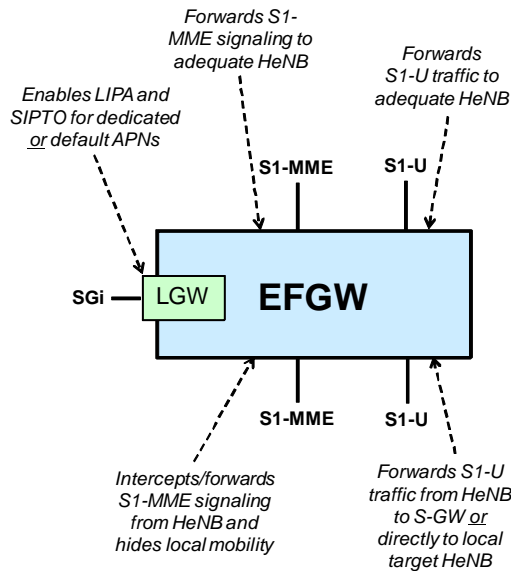

Figure 2-6. Interfaces and core operations of the BeFEMTO EFGW (LFGW)

2.4.1.2 Consistent Access to Enterprise Services

This contribution discusses the end user requirement for enterprise services access. The contribution concludes that, in line with the findings of BeFEMTO, it is highly desirable to enable consistent access to Enterprise Services from both macro-cellular and Enterprise Femtocell Networks (EFN).

To enable consistent access to Enterprise Services, the solutions for remote access mechanisms and local IP access need to be integrated or combined. This means that access to enterprise services should be maintained / continued despite a user losing coverage to the EFN and “handing out” to macro network. Equally, a user who gets access to Enterprise Services while connected to the macro cellular network should have a seamless experience when he “hands in” to the EFN.

The contribution outlines how that could be achieved. Namely, it is proposed to enable the local femto gateway (referred to as EFGW in this contribution) in the femtocell network, which was proposed by WP5 to handle local mobility and local IP access, to also support remote access. As a consequence, the EFGW can act as a mobility “anchor” for both the local IP access and the remote access connections.

The following figure illustrates how the local femtocell gateway can enable seamless handover between local IP access and remote access connections to the Enterprise network during hand-in/out.

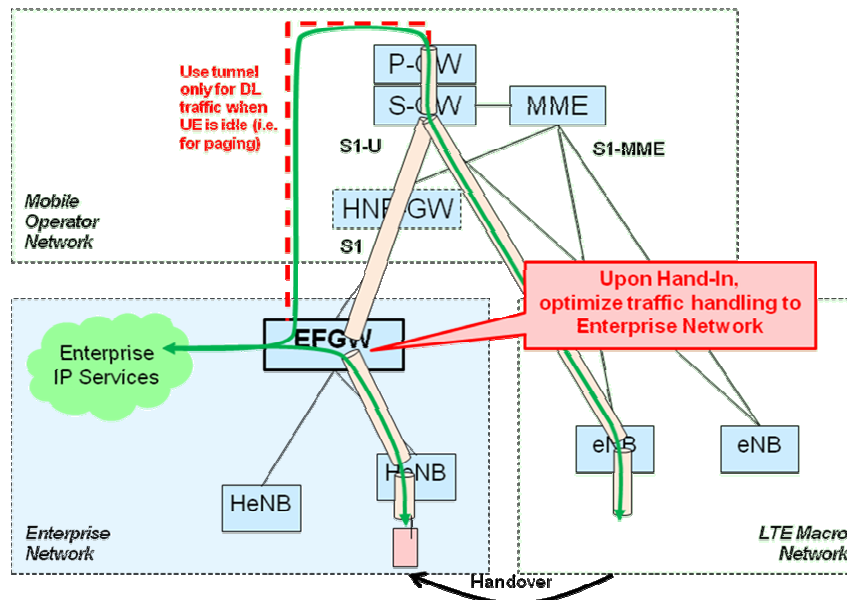

Figure 2-7. BeFEMTO Architecture proposal to support consistent access to Enterprise Services and seamless hand-in/out experience to mobile users

2.4.1.3 LIPA & SIPTO Mobility Support

This contribution presented the status on the 3GPP LIPA & SIPTO Mobility work and recommends a way forward regarding SIPTO Mobility in Rel-12 based on the results of the BeFEMTO work in WP5 on Femtocell Networks.

In summary, the presentation illustrated the open issue regarding the work on LIPA mobility and highlighted that the work on SIPTO@LN is still at an early stage in the discussion in 3GPP. Furthermore, an evaluation of SIPTO@LN use cases revealed that simply reusing the LIPA Architecture proposal for SIPTO@LN has many shortcomings, and is not recommended. The main problem identified is that UEs would require special support to handle i.) multiple simultaneous PDN connection and ii.) the necessary control to associate applications to APNs/PDN connections. For IP flow based SIPTO@LN, the UE would also need to support per-flow routing policies.

2.4.1.4 Wi-Fi / Smallcell Mobility for Local/Enterprise Networks

This contribution presents various solutions for Wi-Fi / Smallcell Mobility in Local/Enterprise Networks and recommends integrating the Local GW functionality as well as support for Trusted WLAN access into the Integrated Femto-WiFi Gateway (IFW-GW).

In summary, the presentation concluded that mobility support for LIPA & SIPTO@LN traffic must be provided by the local network, and that the IFW-GW located in local/enterprise network is a very promising network element to implement such functionality. This would also allow that existing mobility functions – designed for mobility between Wi-Fi and 3G/LTE accesses in the operator core network – can be re-used for providing local Wi-Fi / Smallcell mobility in local /enterprise networks.

2.4.1.5 LTE MAC Scheduler Interface Specification

This document is the specification of the FemtoForum recommended API for LTE Femtocell Schedulers.

2.4.1.6 LTE Network Monitor Mode Interface Specification

This document is the specification of the FemtoForum recommended API for the LTE Femtocell Network Monitor Mode (sniffer) function.

2.4.1.7 LTE eNB L1 API definition

This document is the specification of the FemtoForum recommended API for LTE eNB L1 (MAC-PHY API)

2.4.2 3GPP

2.4.2.1 Downlink Interference Coordination Between eNodeB and Home eNodeB

One contribution was submitted to the 3GPP RAN1 meeting #60 in San Francisco on 22/02/2010. The title of the contribution was "Downlink Interference Coordination Between eNodeB and Home eNodeB" and the document identification is R1-101225.

While co-channel deployment of macro eNBs and HeNBs offers tremendous gains in system capacity, macro UEs that are trapped in the coverage area of a CSG HeNB are exposed to destructive downlink interference. This contribution focuses on mitigating downlink HeNB to macro UE interference through resource partitioning. The basic principle is that HeNBs are denied access to downlink resources that are assigned to macro UE in their vicinity. By doing so, interference to macro UEs is effectively controlled at the expense of a modest degradation in HeNB capacity. The necessary backhaul signalling is conveyed through downlink high interference indicator (DL-HII) messages between eNB and HeNB (or HeNB gateway).

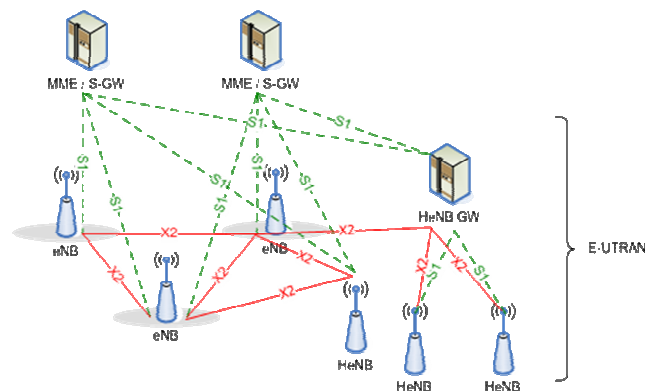

Figure 2-8: Architecture for interference coordination between macrocells and femtocells

For performance evaluation a fixed, system wide interference threshold was assumed, which allows to trade-off macro UE interference protection with femto UE throughput degradation due to resource partitioning. For a interference threshold of -75dB, the median macro throughput of affected UEs that are in close vicinity of a femto-cell is improved from 0.1Mbit/s to 0.56Mbit/s, at the expense of a femto UE degradation from 31.7 Mbit/s to 24.2 Mbit/s. Reducing the threshold to -95dBm gives a ten-fold increase in affected macro UE throughput to 1.1 Mbit/s, but then the femto throughput is almost halved (from 31.7 Mbit/s to 18.9 Mbit/s).

2.4.2.2 Control Channel ICIC for Macro-Femto Deployments

A contribution on "Control channel ICIC for macro-femto deployments" was submitted to the 3GPP RAN1 meeting #63 in Jacksonville on 15/11/2010. The document identification of this contribution is #R1-106186. With CSG (closed subscriber group) femto deployment, non-CSG-member macro UEs may be located in the coverage of active HeNBs. Such macro UEs will experience very heavy downlink interference (on both the control and data channels) from the aggressor HeNBs located nearby. This contribution focuses on the performance of the control channel for such UEs using techniques having no impact for Rel-8/9 UEs.

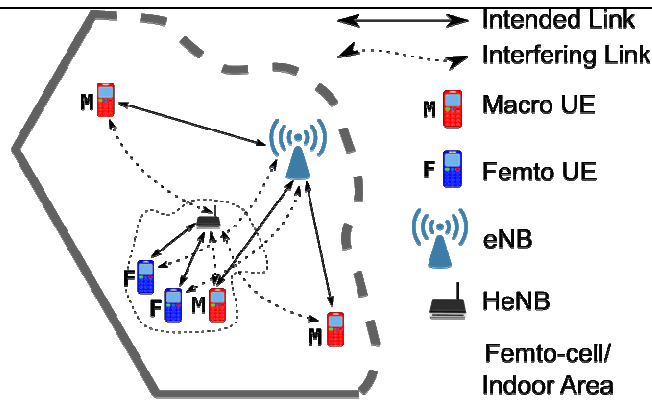

Figure 2-9: Interferences for macrocell UE from femtocells

The techniques available to reduce interference on the PDCCH, PHICH and PCFICH are shown in the following table.

	(a) No coordination	(b) Sparse PDCCH	(c) MBSFN	(d) ABS	(e) ABS + Shift
Pros	1. Femto operation is not hampered	1. Macro UE may receive PDCCH, extended PHICH, and PCFICH 2. Femto can transmit data	1. Macro UE may receive PDCCH, and extended PHICH 2. Macro UE can receive clean PDSCH	1. Macro may receive PDCCH, PCFICH and PHICH	1. Macro can receive PDCCH, PHICH, and PCFICH
Cons	1. PCFICH, PHICH and PDCCH of macro is heavily interfered 2. PDSCH of macro is completely corrupted	1. Macro PCFICH is more interfered than the others (PDCCH and extended PHICH) 2. PDSCH of macro is corrupted. (Thus, PDCCH is for UL grant.)	1. Macro PCFICH has high interference from femto 2. Femto cannot transmit data 3. MBSFN subframes cannot be configured on subframes 0, 4, 5 and 9	1. Macro PCFICH is more interfered than the others 2. Macro PDSCH is interfered by femto CRS 3. Femto cannot transmit data	1. Femto control interferes macro data 2. Macro PCFICH is more interfered than the others 3. Macro PDSCH is interfered by femto CRS 4. Femto cannot transmit data

Figure 2-10: Femtocell to macrocell control channel interference mitigation techniques available

The investigations are summarized as follows:

- ABS, MBSFN, and sparse PDCCH configurations with power setting in femtocell achieve comparable performance with the benchmark case (where HeNB power is set to zero) in terms of lower percentile region of SINR CDF. However, trade-off between HeNB power reduction and femtocell throughput degradation needs further study.

- For PHICH, using the extended PHICH in the macro layer and sparse control channel in the femtocell layer results in improved trapped macro UE performance.
- Sparse PDCCH setting in femtocell is a standard transparent scheme, and beneficial to improve the control channel performance of trapped macro UEs; it would enable macro eNBs to transmit uplink grants even in non-protected subframes, providing additional scheduling flexibility in macro-cell on top of ABS configuration. In addition, sparse PDCCH would also be effective reducing the interference among femtocells. Therefore, it is a backward-compatible interference mitigation scheme that is beneficial to both the macro and femtocell layers.

2.4.2.3 SON, mobility enhancements and X2 interface for HeNB

2.4.2.3.1 SON use cases analysis for scenarios with HeNB

This contribution was submitted to 3GPP RAN3 meeting #68 (R3-101557) in Montreal on 10/05/2010 and describes different use cases where SON for HeNB could be relevant. Two scenarios (see **Figure 2-11**) have been taken into consideration for the analysis: (1) eNB to HeNB interaction and (2) HeNB to HeNB interaction (e.g. enterprise network).

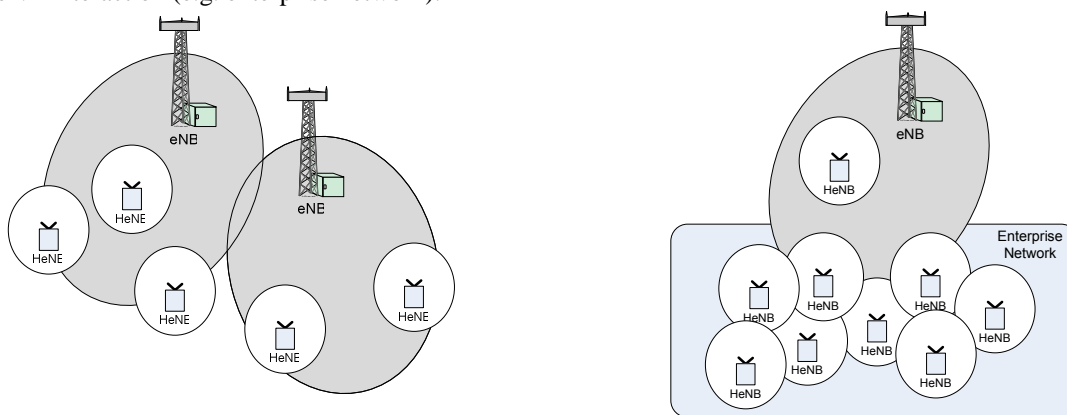

Figure 2-11: HeNB deployment: interaction with macro eNBs (left) and with other HeNBs (right).

The table below summarizes the mapping between the different SON functionalities and their extension and applicability for the two scenarios above, in case of HeNB. The proposal highlighted in the paper is to extend the X2 interface to those scenarios, thus automatically covering SON functions and also explore synergies with other enhancements in the standards, which will also benefit from the X2 interface.

Functionality	Use case	Applicability to Scenario 1	Applicability to Scenario 2
eNB Configuration Update	Automatic Configuration of PCI	PCI split will ensure an appropriate choice of PCIs between eNB and HeNB.	Given the expected large number of HeNB e.g. in dense enterprise networks, automated configuration of PCIs is beneficial.
	RACH Optimization	In scenarios where eNB and HeNB coexist, it is important to minimize interference among them and help for optimized coverage and access performance for setup and handover.	In scenarios where a large number of HeNB are present, it is important to minimize interference among them and help for optimized coverage and access performance for setup and handover.
	Automatic Neighbour Relation Function	Providing ANR functionality in HeNB will be beneficial for mobility and help refining the neighbour relation of the macro eNB and HeNBs.	Given the expected large number of HeNB, and the fact they can be switched on/off, automatic neighbour relation function is beneficial for mobility.
Resource Status Update	Load Balancing	Load information exchange between eNB and HeNB could be beneficial to in dense HeNB networks, to fairly distribute the traffic among nodes.	Load information exchange could be beneficial in dense HeNB networks, to fairly distribute the traffic among nodes.
Mobility Settings Change		Negotiation of parameters with HeNB helps optimizing the performance for scenarios where HeNB are present, for example to adjust user and	

		resource distribution between the cells in case of highly loaded system or dense systems.
RLF Indication	Mobility Robustness Optimization	Rel-9 introduced support for in-bound mobility to a HeNB either from another HeNB or from a macro eNB. Automated optimization of handover is beneficial. To support that, RLF Indication and Handover report are provided.
Handover Report		

Table 2.5: SON use cases for HeNB and applicability to relevant scenarios.

2.4.2.3.2 Mobility Robustness Optimization for HeNB

This contribution was submitted to 3GPP RAN3 meeting #70 (R3-103411) in Jacksonville on 15/11/2010 and illustrates the relevance of MRO SON functionality for scenarios with HeNB.

The paper analysis is based on data collected on large commercial UMTS deployment and look at mobility issues for typical mobility cells (e.g. macro eNBs, where MRO is already available) and for low mobility cells (e.g. HeNB, for which MRO can be easily be made available by extending X2 interface). As can be observed from the summary in table 2.6, the importance of MRO is not different between macro end HeNBs, thus hinting at the need of the functionality for HeNB as well.

	CDR		HO	UL	Mobility
Low mobility	0.28%		8.6%	28.3%	19.9%
Average mobility	0.42%		11.3%	18.1%	18.5%

Table 2.6: Call drop statistics in terms of Call Drop Rate (CDR – on the left) and Cause (right).

2.4.2.3.3 Principles of HeNB-to-Macro mobility optimization

This contribution was submitted to 3GPP RAN3 in an Ad-Hoc meeting (R3-101937), 14/06/2010 and presents a technical analysis for the mobility enhancements of the HeNB-eNB case. Both the direct X2 interface and the X2-Gateway (X2-GW) based approach are considered for adoption, as depicted in Figure 2-12.

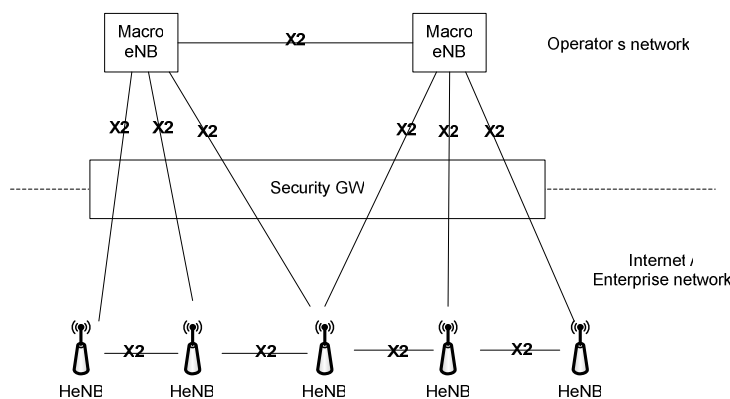

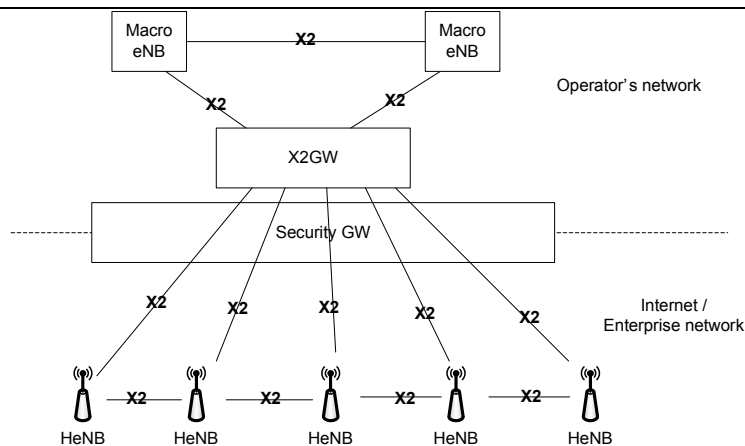

Figure 2-12 Direct X2 interface (top) and X2-GW between HeNB and macro (bottom)

The X2-GW may be helpful in certain deployments, while it may have limited benefits in other cases. In fact, considering that: (a) the number of neighbouring HeNBs under a macro eNB is typically much smaller than under an MME area and that (b) the X2-GW will mainly proxy X2 messages (thus not saving much by message concentration and reduction), the introduction of an X2-GW may not always be justified. On the other hand, additional considerations like desiring a single solution for eNB-HeNB and HeNB-HeNB cases and addressing possible issues about message routing and neighbour relation management in case of X2-GW introduction, should also be considered.

2.4.2.3.4 Inter CSG H(e)NB handover scenarios

This contribution was submitted to RAN3 #73 in Athens, Greece (R3-112033). In real HetNet deployments, operators need to overcome the possible interference scenarios associated with an unplanned deployment of H(e)NB (currently seen as a main drawback), in order to differentiate offered service from IMS bands usage. Depending on the openness or CSG approach, a H(e)NB could potentially interfere with (e)NBs and/or with other H(e)NBs. This contribution gives an approach for the relaxation of possible interference scenarios on foreseen dense CSG deployments, in which neighbour CSGs H(e)NBs are open to collaborate.

2.4.2.4 Problem Scenarios and Proposed Solutions for Home BS Coexistence

This contribution was submitted to 3GPP RAN4 meeting #57 (R2-106200) in Jacksonville on 15/11/2010 and presents the interference scenarios between LTE bands and ISM bands (i.e. Wi-Fi), considering the use of LTE bands by Home Base Stations.

In the 3GPP there is a study item [2] on the in-device coexistence interference avoidance analysis between LTE and ISM bands. The rationale for this activity is that the ISM band (2.4-2.48 GHz) is close to LTE Band 40 (2.3-2.4 GHz intended for LTE TDD) and also to LTE Band 7 (2.5-2.6 GHz for LTE UL).

This contribution proposes to expand the scope of the Study Item to include Home Base Stations as a particular case of in-device coexistence, and taking into account the 5 GHz ISM band. The rationale for this proposal is that the interference scenarios are very similar to those expected in a User Equipment, and at the same time some Home Base Station manufacturers are expected to provide dual Wi-Fi / HSPA equipment in a short time, thus in the next future dual Wi-Fi / LTE Home Base Stations should also be available and severe interference between both radio interfaces will be possible.

The coexistence scenarios from the point of view of LTE can be categorized into the following scenarios:

- Scenario 1.** Home Base Station LTE receiver (LTE Band 40 and LTE Uplink Band 7) experiencing interference from 2.4 GHz ISM band.
 LTE Uplink Band 7 (2500 – 2570 MHz) and LTE TDD Band 40 (2300 – 2400 MHz) can be easily desensitized from the emissions of a 2.4 GHz ISM transmitter (2400 – 2484.5 MHz) co-located within the same Home BS. The problem will arise from the limited selectivity of the bandpass filter (or duplexer) placed before the LTE receiver's low noise amplifier, that in the case of nearest bands could be only 5- 10 dB, and a Minimum Coupling Loss (MCL) between the ISM transmitter and the

LTE receiver of 30 dB. Considering a WiFi transmitter power of 20 dBm, the LTE low noise amplifier can experience an interference power of about -15 / -20 dBm, which will make the full LTE band 40 and LTE Uplink Band 7 completely inoperative.

- Scenario 2.** Home Base Station 2.4 GHz ISM Band receiver experiencing interference from LTE Band 40. LTE.
LTE TDD Band 40 (2300 – 2400 MHz) can easily desensitize the 2.4 GHz ISM receiver (2400 – 2484.5 MHz) co-located within the same Home BS, in particular when LTE TDD Band 40 transmitter makes use of the frequencies closer to 2400 MHz. Like in Scenario 1, the problem will arise from the limited selectivity of the band pass filter placed before the Wi-Fi receiver's low noise amplifier.
- Scenario 3.** Home Base Station 2.4 GHz ISM Band receiver experiencing interference from LTE Uplink Band 7. LTE.
LTE FDD DL Band 7 (2620 – 2690 MHz) is far enough from the 2.4 GHz band (2400 – 2484.5 MHz) and thus is reasonably easy to prevent any desensitization of the Wi-Fi receiver by means of a simple band pass filter.
- Scenario 4.** Home Base Station 5 GHz ISM Band receiver experiencing interference from the second harmonic of LTE Uplink Band 7. LTE
The second harmonic of the LTE Downlink Band 7 emission (5240 – 5380 MHz) can desensitize the receiver of a Wi-Fi device operating in the 5150 – 5350 ISM band when they are co-located within the same Home BS. 3GPP TS 36.104 "E-UTRA Base Station radio transmission and reception" does not provide any special transmission spurious requirements in the ISM bands (see Section 6.6 Unwanted emissions".
Taking into account a conservative MCL between the LTE transmitter and the ISM receiver of 30 dB, the Wi-Fi low noise amplifier can experience an interference power of about -66 dBm, which will reduce the sensitivity of the WiFi receiver. The IEEE 802.11n [7] specification, specifies a receiver sensitivity of -64 to -66 dBm for 64 QAM modulations, and of -74 to -70 dBm for 16 QAM modulations (see section 20.3.22.1 Receiver minimum input sensitivity), can be clearly degraded in the presence of a -66 dBm spurious.

In the contribution are proposed solutions for each individual scenario, consisting on disabling the use of a determined part of the frequencies of the interfering band nearby the interfered system band.

2.4.2.5 R3#70BIS, Dynamic H(e)NB Switching by Means of a Low Power Radio Interface for Energy Savings and Interference Reduction

This contribution was submitted to RAN3 #70 Bis in Dublin, Ireland (R3-110030). We are analyzing a scenario where a UE in active or idle mode needs to be handed over from a (e)NB to a H(e)NB which will be switched off when no UE is camping in it. The goal is to keep the H(e)NB transceiver off for as long as possible, and to switch it on only when the UE is in the most close vicinity of it, around 10 to 15 meters; i.e. when the user arrives home, and switching it off as soon as the user leaves the surroundings of the home. By switching on or off we mean only the radiofrequency section of the H(e)NB, which is the responsible of its radio interference and most of its power consumption, keeping all the other sections of the H(e)NB active and connected to the EPC.

The proposed switching procedure approaches are based on the automatic detection of the UE presence by means of any low-power radio interface active in the UE, Bluetooth Low Energy interface being a good candidate thanks to the widespread use of Bluetooth in many UE and its low power characteristics. We are proposing that this radio interface is turn on active in the UE when it detects the macrocell that is closest to the H(e)NB, and inactive when the UE does not detect this macrocell, or also inactive when the UE is camped in the H(e)NB, in order not degrading significantly the battery lifetime.

2.4.2.6 SA2#84, Standalone Local Gateway Architecture Variant (NEC)

This contribution was submitted to SA2 #84 in Bratislava, Slovakia (S2-111725). SA2 agreed to study an architectural variant, whereby the LGW can be a standalone functional entity. To support this variant, a new interface ("Sxx") between the H(e)NB and LGW needs to be standardized, along with the necessary mobility management procedures to support inter-H(e)NB handover while maintaining the LIPA and/or SIPTO connections.

Besides the need to standardize this new Sxx interface, this architecture variant has the following open issues:

- The discovery of the L-GW S5 interface address (provided by the SeGW) by the H(e)NBs in the enterprise.
- How the tunnels between the H(e)NBs and the L-GW are established.
- How the secure tunnel transporting the S5 interface between the L-GW and the SGW is established.
- The procedures for the handover over the Sxx interface.

This contribution proposes an alternative architectural variant, whereby the L-GW is located on Iuh/S1 path between the H(e)NB and the operator network, as illustrated in Figure 2-13. This architecture is based on the Local Femto Gateway (LFGW) concept developed as part of the BeFEMTO work on Femtocell Networks in WP5.

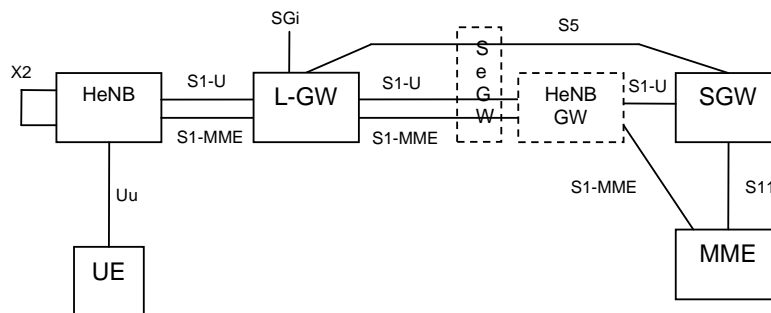

Figure 2-13 Stand-alone L-GW located on the S1 path (Variant 2)

During the presentation of the solution, several comments / questions were raised regarding relationship of this approach with the Rel-10 L-GW architecture, the architectural variant 1 proposed for Rel-11, and the already existing H(e)NB GW function. It was therefore agreed to further discuss and revise this solution offline until the next SA2 meeting.

This contribution introduces an architectural variant for the standalone L-GW, which supports LIPA/SIPTO mobility based on Rel-10 handover procedures and does not rely on a new H(e)NB – L-GW interface.

2.4.2.7 SA2#85, Standalone Local Gateway Architecture Variant (NEC)

This contribution was submitted to SA2 #85 in Xi'An, P.R. China (S2-112701), and is a revision of the contribution submitted to SA2 #84 in Bratislava, Slovakia (S2-111725). The revised version took into account the comments / questions raised at SA2#84 and addressed the open issues.

In particular, the document clarified the relation of the proposed architecture to the Rel-10 L-GW functionality and the existing Rel-10 H(e)NB architecture, and the intension to re-use as much as possible by moving the L-GW into a standalone node (as illustrated in **Figure 2-14**).

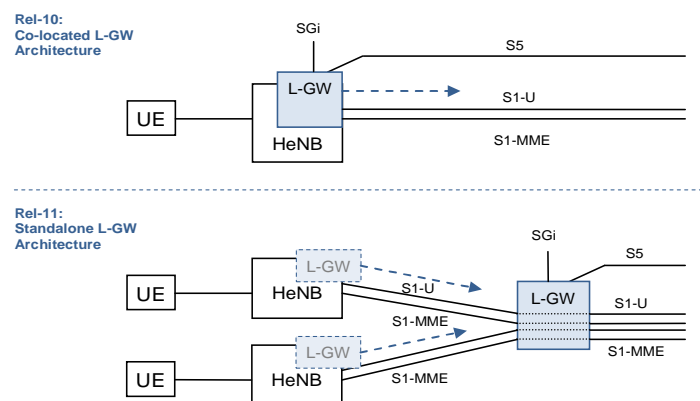

Figure 2-14 From a co-located to a standalone L-GW architecture

The advantage of this approach is that this architecture can reuse the existing Rel-10 handover procedures defined for the inter-H(e)NB handover. Routing of the Iu/S1 connections through the L-GW is enforced either via tunneling approaches between the H(e)NB and the L-GW, or through local configuration.

In addition, this architecture has the following advantages:

1. The L-GW provides the S5 interface address to the MME on the S1 interface (piggybacking it on the relevant S1 messages). Hence, there the problem of LGW address discovery is resolved.
2. No need for standardization of new handover procedures for the standalone L-GW: since the L-GW acts as a relay/proxy on the Iuh/S1 interface, the existing handover procedures defined for inter-H(e)NB mobility via Iuh/S1 (according to TS 25.467 and TS 36.300) can be reused to enable LIPA (and SIPTO) mobility.
3. Low signaling load for LIPA mobility: since the L-GW is located on the Iuh/S1 path, no additional, dedicated handover signaling is needed to update the LIPA(SIPTO) connection to the L-GW.
4. The H(e)NB do not need to support a new interface, i.e no requirement to support Sxx (e.g. GTP-C). The H(e)NB continue to support only S1/Iuh interface as in Rel-9/10.

Since the L-GW can potentially also act as a local mobility anchor, the signaling load stemming from frequent intra-CSG H(e)NB handovers (e.g. in case of medium-to-large Enterprise H(e)NB network) may also be handled locally.

This contribution was agreed to be captured as one alternative architecture variant in 3GPP TR 23.859 on “LIPA Mobility and SIPTO at the Local Network”.

2.4.2.8 SA2 #86 Discussion paper for Standalone L-GW Architecture Option 2 (NEC)

This contribution was submitted to SA2 #86, Naantali, Finland (S2-113598). It discusses the main design principle behind the Standalone L-GW Architecture Option 2 and presents the technical details of some of the open issues identified at SA2#85. In particular, the following technical details were clarified:

1. How is the Standalone L-GW included into the Iuh/S1 path?

The existing Rel-10 O&M provisioning mechanism can be used by the operator to re-configure a H(e)NB – after successful authentication by the core network SeGW and location verification by the HMS – to connect through a standalone L-GW in the LHN. Figure 2-15 shows the individual steps.

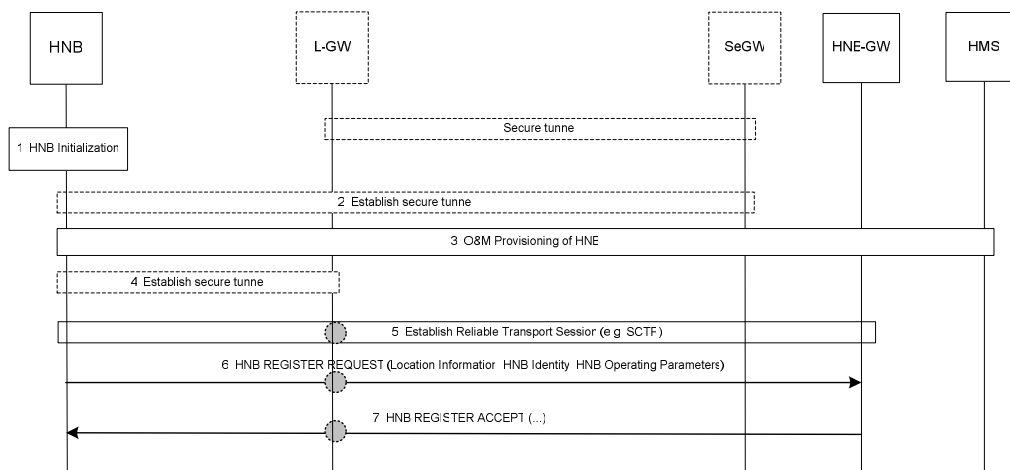

Figure 2-15 How the Standalone L-GW is included into the Iuh/S1 path

Figure 2-16 shows in more details how the IPsec tunnels are established from the L-GW towards the SeGW and from the HNBs towards the L-GW.

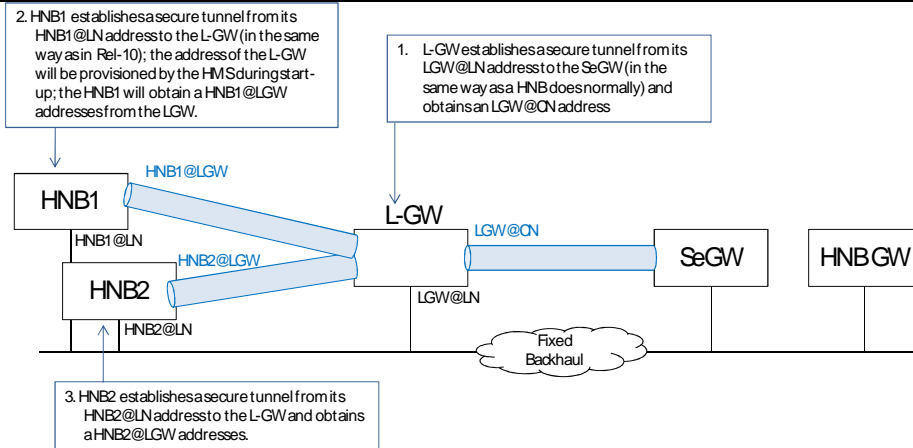

Figure 2-16 IP address allocation and secure tunnel establishment

2. SCTP connection establishment and proxy configuration

Figure 2-17 shows how the H(e)NBs establish their SCTP connections towards the HNB GW or HeNB-GW/MME. The L-GW, which acts as SCTP proxy, forwards the SCTP connection request to the operator network.

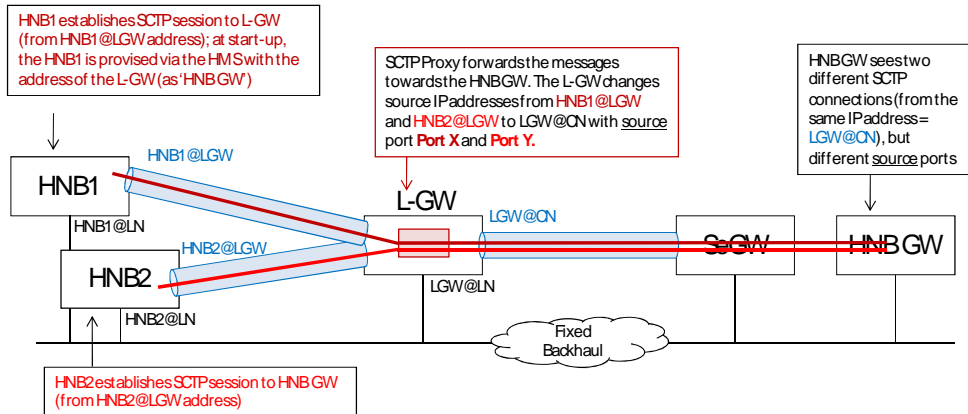

Figure 2-17 SCTP connection establishment and proxy configuration.

3. GTP bearer establishment and proxy configuration

Figure 2-18 shows the C-Plane processing at the L-GW during bearer establishment on Iuh/S1 path and the associated U-Plane processing. The standalone L-GW monitors the Iu/GTP related control plane signalling for the bearer establishment, and acts as a GTP-u proxy in the user plane between the H(e)NBs and core network entities.

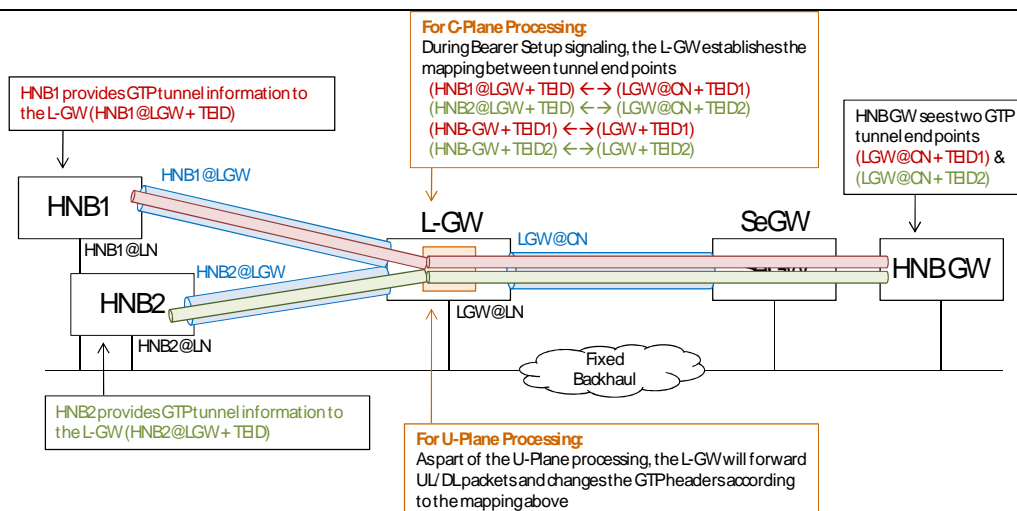

Figure 2-18 GTP bearer establishment and proxy configuration.

2.4.2.9 SA#2 Details of Standalone L-GW Architecture Option 2 (NEC)

This contribution was also submitted to SA2 #86, Naantali, Finland (S2-113758) and is the corresponding Pseudo CR (P-CR) to the discussion paper provided in S2-113598. It supplies the detailed message flows for the Standalone L-GW Architecture Option 2 and suggests to include them in 3GPP TR 23.859 as part of a new Annex. This P-CR was eventually agreed by SA2 #86.

As a consequence, the BeFEMTO Local Femto Gateway (LFGW) solution – including the detailed message flows – has been captured as one architectural option in 3GPP Technical Report on LIMONET (TR 23.859).

2.4.2.10 R3#72, Hybrid OAM and signalling based approach for E-UTRAN cell waking up from dormant mode

This contribution was submitted to RAN3 #72 Barcelona, Spain (R3-111298). In TR 36.927 two scenarios of inter eNB energy saving are considered. In the scenario 1 boost capacity cells coverage area is included on the basic coverage cells, and in the scenario 2 the compensation cells provide basic coverage on areas previously covered by so called energy saving cells when they are on dormant mode. For scenario 2, two solutions have been considered, namely OAM based solution and Signalling based solutions, with the following main characteristics:

- **OAM based solution.** This solution relies on OAM control that would use long term statistics or fixed wake-up/ dormant periods for the energy saving cells, being a less flexible approach than the signalling based solution. The decision to enter or leave the dormant state comes from OAM, this has the advantage of a high level of network control from OAM central point. On the other hand this solution supposes a low impact in the eNBs that will receive control commands. The drawback is then on the low reaction time to real network traffic needs.
- **Signalling based solution.** In this approach the cells are aware of whether are compensating cells or energy saving cells based on proprietary information or optionally by OAM. The compensation cells control the cells on dormant and wake up state, based on the information exchanged with the energy saving cells. This solution has a small impact on OAM, but needs of signalling load between eNBs, through intercell X2 messages. The solution is highly flexible because it can react on real time to load changes but presents the problem that does not include the possibility to adjust cell group coverage parameters, and this can lead to inadequate group coverage resulting in deployment coverage holes or excessive intercell interference. For example, if basic coverage is considered for indoor there is not a clear mechanism to be changed to outdoor, cell with overreach due to street canyons, cells with short radius due low antenna high and surrounding obstacles, etc.

Therefore, a hybrid approach can provide a most effective, controlled and flexible energy saving mechanism, with real time reaction of the signalling based solution and with the possibility of the individual cell group coverage control offered by OAM.

In the hybrid OAM and signalling solution, the cells are preconfigured as potential compensation cells or energy saving cells by OAM, and OAM additionally communicates the values of some parameters that control the management of the switching on/off of the group of cells controlled by a compensation cell.

2.4.2.11 R3#73, Analysis of scenarios with energy saving cells and compensation cells

This contribution was submitted to RAN3 #73 Zhuahi, China (R3-111298). For inter-eNB energy saving, two scenarios have been defined in TR 36.927. In the scenario 2, three solutions have been considered, based on a hierarchy that defines two classes of cells, compensation cells and energy saving cells.

The first solution is based on OAM, in which the cells switch on/off based on an algorithms configured by OAM, with low impact on eNB but with high impact on OAM.

The second solution is a signalling based solution that is based on inter-cell coordination, being OAM only optionally needed to indicate which cells are configured as compensation cells and which are configured as energy saving cells. As third solution, it is included a hybrid mechanism, based on both signalling and OAM based procedures.

Actually, depending on the used parameters configuration, this hybrid approach could behave as any of the first two approaches, allowing several other possibilities that add to it more flexibility and adaptability to different scenarios for energy saving procedures. In the hybrid OAM and signalling solution, the cells are preconfigured as potential compensation cells or energy saving cells by OAM, and OAM also communicates the values of some parameters that manage the switching on/off algorithm of the cells.

The aim of this contribution is to analyze scenarios with energy saving cells and compensation cells, pointing out which are the standardization needs for possible approaches to the foreseen energy saving mechanisms

Carrier-based HetNet ICIC (QC)

2.4.2.11.1 Use Cases for carrier-based HetNet ICIC in LTE

This contribution was submitted to RAN3 #73 in Athens, Greece (R3-112120).

In this contribution some considerations for selecting the use cases of the carrier-based HetNet ICIC work item were presented. Based on the included analysis, we recommended the following proposals:

- **Proposal 1:** For the scope of this work item and related use cases, it is proposed to distinguish between two groups of carrier resources, the “basic resources” and the “additional resources”, and to capture that in the TR.
- **Proposal 2:** The scope of work should primarily focus on selection mechanisms for additional resources, while adapting basic resources are preferably not considered for use case of interest.
- **Proposal 3:** The scope of work should prioritize macro-pico deployments, with main focus on the macro-pico interaction and considering also the pico-pico case.
- **Proposal 4:** The scope of work should also consider HeNBs, with focus on enterprise deployments with inter-HeNB interactions and considering the case of multiple carriers HeNB if capabilities are extended in Rel-11.
- **Proposal 5:** Power adjustment mechanisms for additional (non-anchor) resources should be also considered in the scope. However, it is recommended that RAN3 carefully assesses the mechanism complexity and possible risks of unstable configurations as part of the work item.

2.4.2.11.2 Carrier-based HetNet ICIC use cases and solutions

This contribution was submitted to RAN3 #73bis in Zhuhai, China (R3-112609). In this contribution the prioritized interference scenario for the HetNet ICIC WI were analyzed and available mechanisms to assist the carrier selection of users in heterogeneous deployments with CA were identified.

As a conclusion, the following proposals, to be captured in the RAN3 technical report (TR) were made:

- **Proposal 1:** It is proposed to: (a) study the use case of macro-pico interference with particular reference to the optimization of carrier selection (Pcell/Scell allocation) of users around CRE region when CA-ICIC is used to manage interference and (b) to capture the description and preliminary analysis included here it the TR.

- **Proposal 2:** In case inter-eNB assistance is found beneficial, it is proposed to first consider the re-use of the RNTP IE included in the Load Information message for assisting carrier selection in HetNet deployments and to capture this as baseline in the TR.
- **Proposal 3:** In case inter-eNB assistance is found beneficial, it is proposed to
 - Consider the adoption of TDM ICIC procedural approach to assist carrier selection in HetNet scenarios
 - Discuss the extension of the current RNTP reporting mechanisms by enabling an eNB to indicate to another eNB the RNTP threshold it likes to receive a report about

2.4.2.11.3 Carrier-based HetNet ICIC for DL interference scenario

This contribution was submitted to RAN3 #74 in San Francisco, USA (R3-113022). In this contribution the prioritized interference scenario for the HetNet ICIC WI were analyzed and available mechanisms to assist the carrier selection of users in heterogeneous deployments with CA were identified.

As a conclusion, the following proposals, to be captured in the RAN3 technical report (TR) were made:

- **Proposal 1:** It is proposed to: (a) study the use case of DL macro-pico interference with particular reference to optimization of carrier selection (Pcell/Scell allocation) of users around CRE region when carrier-based ICIC is used to manage interference and (b) to capture the analysis included here and its summary in Table 1 in the TR.
- **Proposal 2:** In case inter-eNB assistance is found beneficial, it is proposed to first consider the re-use of the RNTP IE included in the Load Information message for assisting carrier selection in HetNet deployments and to capture this as baseline in the TR.
- **Proposal 3:** In case inter-eNB assistance is found beneficial, it is proposed to also consider extending it to the control region and investigating what information exchange could be used for assisting carrier selection in HetNet deployments via X2-AP.
- **Proposal 4:** In case inter-eNB assistance is found beneficial, it is proposed to
 - Adopt a message exchange framework similar to what defined for TDM ICIC to assist carrier selection in HetNet scenarios
 - Discuss the extension of the current RNTP reporting mechanisms by enabling an eNB to indicate to another eNB the RNTP threshold it likes to receive a report about

2.4.2.12 Mobile Relays (QC)

2.4.2.12.1 The Location of the Mobility Anchor for Mobile Relays

This contribution was submitted to RAN3 #74 in San Francisco, USA (R3-113020). This contribution has discussed the various options for the placement of the mobility anchor for the Mobile Relay and its connected UEs.

It is proposed to capture the following principles in the RAN3 technical report (TR):

- **Principle 1:** The PGW/SGW function of the Mobile Relay is a logically separate function from the DeNB reusing the S1 interface to the DeNB.
- **Principle 2:** A PGW/SGW function for the UE located in the core network shall be supported.
- **Principle 3:** A PGW/SGW function for the UE collocated in the Mobile Relay may be supported. The same principles as defined for SIPTO/LIPA GW selection can be used to offload the UE traffic at the Mobile Relay.

2.4.2.12.2 The Termination of the X2 and S1 Interfaces for Mobile Relays

This contribution was submitted to RAN3 #74 in San Francisco, USA (R3-113021). This contribution has discussed the various options for support group mobility for the Mobile Relay and its connected UEs.

It is proposed to capture the following principles in the RAN3 technical report (TR):

- **Principle 1:** The X2 interface for the Mobile Relay is not considered in the study item in Rel-11.
- **Principle 2:** The S1 interface for the Mobile Relay is terminated at the MME using the existing S1 setup procedures.
- **Principle 3:** The Mobile Relay is assigned a Tracking Area and eNB ID that are independent of the serving DeNB's Tracking Area and eNB ID, and the assigned IDs do not change due to relay HO events. Therefore, relay HO events are transparent to any UEs camped or connected to the Mobile Relay.

2.4.3 ETSI

A contribution on “Application of Cognitive Radio and Software Defined Radio for multi-radio communications in the home” was presented to the ETSI Technical Committee of Radio Reconfigurable System (RSS) meeting RSS#9. The document identification of this contribution is RRS(10)0015. This contribution focuses on the challenges on the provision of new services at home that sometimes can suppose the change of home support nodes. In this contribution the use of a flexible multi-radio platform is proposed, being able to accommodate present and future services and radio interfaces. The presentation includes a reference to the BeFEMTO project as place where the investigation is taking place. Next figure presents an example of multi-radio Home Node implementation.

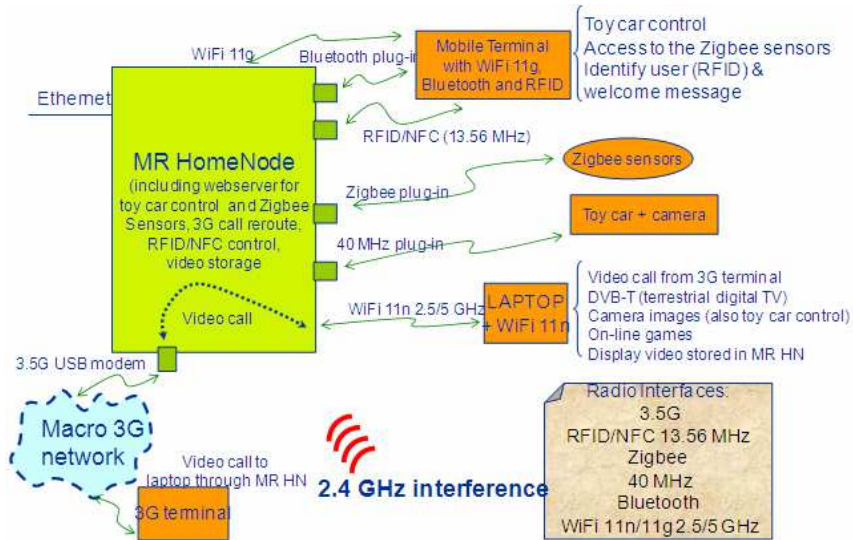

Figure 2-19 Multi radio Home referenced in the presentation to the ETSI TC RSS#9

3. Dissemination

Dissemination activities for BeFEMTO project were performed in task 7.2 as part of the WP7, during the whole duration of the project. These activities summarize the outputs generated by all the WPs involved in BeFEMTO, in order to spread the knowledge created in the project to a public beyond the group of participants.

This section is divided in two sub-sections: the first one describes the dissemination plan, whose goal was to share the awareness to both internal and external audience, through collaborative server, meetings, papers in conferences, organizations of international workshops, training schools, etc. The second sub-section reports all the dissemination results achieved in the project, from the kick-off (M1) until the end of the project (M30). The overall results of dissemination cover more than the initial dissemination targets, fulfilling widely the goals described in the DoW.

3.1 Dissemination Action Plan

From the beginning of the project, BeFEMTO has adopted different ways to disseminate the know-how created in the project: one is the internal dissemination, with actions aiming at ensuring a good diffusion of documentation among the project partners with the aim of sharing the developed expertise, and the second one is the external dissemination, in order to guarantee the visibility and awareness of the results outside the project consortium.

In particular, the external visibility and public knowledge of the BeFEMTO project have been ensured through the following dissemination channels: papers submitted at conferences and workshops, articles published in journals and magazines, presentation at events, organization of international workshops and training schools, creation of a public project website and other channels in internet, etc.

Furthermore, the Consortium has a public collaborative group in internet [3], where it has been possible to exchange ideas about femtocells and it has been used as an active way to introduced discussions about the areas related to BeFEMTO.

On the other hand, in the internal dissemination area, a consortium collaborative server has been set up for the dissemination and exchange of documents, drafts, ideas, etc. and to ensure the visibility of the correct activities' progress within the project. The necessary documents for the dissemination planning and tracking of the results have been created on this server. Access is restricted to partners of the consortium and the EC, and it's protected by user authentication. The aim of this structure was to have a common place to track the planned actions and progress regarding dissemination.

Several mailing lists, organized by technical areas of the project, have been set up. Also, internal meetings have been organized during the working period of the project.

Next table (Table 3-1) summarises the target audience in each of the dissemination channel employed in the project.

Dissemination channel	Destination
Public website	Public
Papers at Conferences and Workshops	Public: scientific audience.
Articles in Journals and Magazines	Public
Presentations at events	Public
Workshops, panel sessions and training schools	Public
Post graduate courses	Public: academic audience.
Wikipedia	Public
BeFEMTO linkedin group	Public: scientific and industrial audience.
BeFEMTO YouTube Channel (Videos)	Public
Book	Public
Mailing lists	Internal: partners. All, WPs, PMT, Board. etc.
Collaborative server	Internal: partners and EC.
Internal meetings	Internal: partners.

Table 3-1. Dissemination channels and destination

The following sections will describe the dissemination actions in each of the dissemination channels presented before.

3.1.1 Conferences and Workshops

The partners contribute to dissemination of the project results and innovations in top ranked scientific conferences such as PIMRC, GLOBECOM, ICC, VTC, etc. External workshops relevant to the topic of the research activity were planned and carried out during the project, in order to facilitate the development of a wider consensus in standards.

3.1.2 Journals and Magazines

The publication of articles in high quality scientific journals and magazines (e.g. IEEE) is desirable to publicize the project results and its innovation.

3.1.3 Books

The project includes the edition of a book on LTE-A Femto technologies developed in BeFEMTO, which will be written in the second half of 2012.

3.1.4 Presentations at events

The Consortium has attended to international events where an overall approach of BeFEMTO femtocells and the knowledge achieved will be presented. As there have been other projects (collaborative projects as well as support actions) targeting the same objective as BeFEMTO (ICT-2009.1.1 The Network of the Future) and contributing to different aspects of future networks, BeFEMTO has participated and interacted with these projects (e.g. FREEDOM) in order to add the femtocells domain to the overall vision by exchanging concepts, requirements and solutions to build a consolidated approach.

3.1.5 Plenary meetings and annual meeting with project's Advisory Board.

The BeFEMTO dissemination has included the organisation of an annual meeting with the project advisory board to discuss the scientific as well as radio regulatory issues identified in BeFEMTO.

3.1.6 Organization and sponsorship of events

The organization and sponsorship of events at two (2) international workshops, one (1) training school and one (1) panel session.

3.1.6.1 International Workshops and panel sessions

As part of the dissemination activity, BeFEMTO organizes at least two international workshops with open participation, for dissemination of public results. The workshops have been highlighted in high quality conferences such as IEEE VTC and FuNEMs. The purpose of these workshops have been to provide a platform for researchers working around the globe on femtocells to interact with each other and in particular to benefit from the expertise developed in BeFEMTO project and to exchange information with research activities in other regions as part of international consensus building.

3.1.6.2 Training School

The organisation of training schools on some of the issues under investigation within BeFEMTO has been another target in the project dissemination.

3.1.7 BeFEMTO website

A public website has been set up at www.ict-befemto.eu for the dissemination and exchange of documents, for instance public deliverables that allow the general public to gather information about the project. This webpage includes other relevant material that the project could decide to disseminate.

The public website presents general project information, scientific publications done during the project, news about the project, events organized and public downloadable deliverables. Public documents, made available through the project public website, can be utilized by third parties to enhance their projects but also have given these parties the possibility to provide feedback and thus to improve the results of the project. The website has been regularly updated with all the information developed during the whole project.

3.2 Dissemination Results

This section summarizes the results reached by the partner's contributions to dissemination activities during the 30 months of the project duration. BeFEMTO has focused its dissemination activities in broadcasting the objectives and results of the BeFEMTO research to a wider external audience (industrial, scientific and non-scientific public) ensuring wide-spread familiarization of BeFEMTO's technologies.

The very first period of dissemination was oriented towards setting up of tools and structures that help internal circulation of information, which was followed by **fifty-nine (59) scientific papers** and attendance to international conferences and workshops (PIMRC, GLOBECOM, VTC, FuNEMS, WCNC, ICC, etc.), followed by the organization of **five (5) workshops** in international events (VTC 2011 in Budapest (Hungary), FuNEMS 2011 in Warsaw (Poland), WCNC 2012 in Paris (France), ICC 2012 in Ottawa (Canada) and ICCCN 2012 in Munich (Germany)), with high qualified keynote speakers from academia and industry, panel sessions and international scientific papers. BeFEMTO academic partners have organized **two (2) international training schools**: one winter school in Barcelona (Spain) in collaboration with other European project, and one summer school in Oulu (Finland). On the other hand, **five (5) panel sessions** have been carried out, one of them in the PIMRC 2011 conference in Toronto (Canada) and the other ones during the international workshops organized by BeFEMTO.

Other channels of dissemination included in the project dissemination activities are presentations at events (including the Concertation process), internal meetings, the project website and internet links (**wikipedia**, BeFEMTO linkedin group, BeFEMTO YouTube channel, etc.) and the edition of **two (2) books** related to the investigations carried-out within BeFEMTO, which are foreseen in the first half of 2013 (1 book with Wiley, 1 book with Cambridge University Press).

Dissemination item		Result	Target
Standard/industry alliance Contributions	3GPP	19	
	Femto Forum	7	
	ETSI	1	
Scientific papers (Conferences, ...)		59	
Journal articles		10	
Special issues (Editing)		2	
Organized Workshops		5	2
Training Schools		2	1
Panel Sessions		5	1
Presentations at events		23	
YouTube Channel	Videos	23	
	Views	10772	
Linkedin followers		222	
Books proposals		2	1
Books contributions		4	
Website visitors		13085	
Deliverables downloaded		215	

Table 3-2 Dissemination results of BeFEMTO

Dissemination Results per period		RP1 2010	RP2 2011+2012	TOTAL
Standard/industry alliance Contributions	3GPP	6	13	19
	Femto Forum	5	2	7
	ETSI	1	0	1
Scientific papers (Conferences, ...)		14	45	59
Journal articles		3	7	10
Special issues (Editing)		0	2	2
Organized Workshops		0	5	5
Training Schools		0	2	2
Panel Sessions		0	5	5
Presentations at events		5	18	23
YouTube Channel	Videos	0	23	23
	Views	0	10772	10772
Linkedin followers			222	222
Books proposals		0	2	2
Books contributions		0	4	4
Website visitors		3144	9941	13085
Public Deliverables and IR downloaded		19	196	215

Table 3-3 Dissemination results of BeFEMTO (per Reporting Period)

The following sections detail the dissemination results.

3.2.1 Conferences and Workshops

The BeFEMTO consortium has presented the objectives and results of the research in various venues, at a number of international workshops and conferences such as IEEE VTC 2010 and 2011, FuNEMS 2010 and 2011, IEEE PIMRC 2010 and 2011, IEEE GLOBECOM 2010 and 2011, IEEE ASILOMAR, IEEE WCNC 2011 and 2012, WIRELESS VITAE 2011, IEEE ICC 2011 and 2012, IEEE ANTS 2011, IEEE CCNC 2012, IEEE Wiopt 2012, W-GREEN workshop, Indoor Outdoor Femto Cells (IOFC) workshop, etc.

Previously to publication and presentation, the papers have been approved by all the partners. The publications are approved under the condition they do incorporate the right Acknowledgement as described in the Management Handbook.

The dissemination done about the BeFEMTO knowledge, through papers in conferences and workshops is summarized in the following list (listed by date):

1. **VTC 2010 Spring Conference [4]**, 16th – 19th May 2010 (Taipei, Taiwan)
Title: “Distributed Q-learning for Interference Control in OFDMA-based Femtocell Networks”
Authors: Ana Galindo-Serrano and Lorenza Giupponi
BeFEMTO partner: CTTC
2. **FuNEMS 2010 Conference [5]**, 16th – 18th June 2010 (Florence, Italy)
Title: “BeFEMTO’s Self-Organized and Docitive Femtocells”
Authors: Ana Galindo Serrano, Lorenza Giupponi and Mischa Dohler
BeFEMTO partner: CTTC
3. **IEEE PIMRC 2010 Conference [6]**, 26th – 29th September 2010 (Istanbul, Turkey)
Title: “A Potential Game for Distributed Interference Control in OFDMA-based Femtocells”
Authors: Lorenza Giupponi and Christian Ibars
BeFEMTO partner: CTTC
4. **IEEE PIMRC 2010 Conference [6]**, 26th – 29th September 2010 (Istanbul, Turkey)
Title: “A Radio Resource Management Scheduling Algorithm for Self-organizing Femtocells”
Authors: A. de Domenico and E. Calvanese Strinati
BeFEMTO partner: CEA
5. **IEEE PIMRC 2010 Conference [6]**, 26th – 29th September 2010 (Istanbul, Turkey)
Title: “Distributed Power Allocation for Interference Limited Networks”
Authors: C. Abgrall, E. Calvanese Strinati and J-C Belfiore
BeFEMTO partner: CEA
6. **IEEE PIMRC 2010 Conference [6]**, Indoor Outdoor Femto Cells (IOFC) workshop, 26th – 29th September 2010 (Istanbul, Turkey)
Title: “On Spectrum Sharing with Underlaid Femtocell Networks”
Authors: M. Bennis and M. Debbah
BeFEMTO partner: UOULU
7. **IEEE PIMRC 2010 Conference [6]**, Indoor Outdoor Femto Cells (IOFC) workshop, 26th – 29th September 2010 (Istanbul, Turkey)
Title: “Interference Avoidance via Resource Scheduling in TDD Underlay Femtocells”
Authors: F. Pantisano, M. Bennis, K. Ghaboosi and M. Latva-aho
BeFEMTO partner: UOULU
8. **IEEE PIMRC 2010 Conference [6]**, **W-GREEN workshop**, 26th – 29th September 2010 (Istanbul, Turkey)
Title: “Interference Management for Self-Organized Femtocells towards Green Networks”
Authors: C. H. M. de Lima, M. Bennis, K. Ghaboosin and M. Latva-aho
BeFEMTO partner: UOULU

9. **IEEE ASILOMAR [7]**, 7th – 10th November 2010 (Pacific Grove, USA)
Title: “Learning Mechanisms for Interference Mitigation in Self-Organized Femtocells”
Authors: M. Nazir, M. Bennis, K. Ghaboosi, A. Mackenzie and M. Latva-aho
BeFEMTO partner: UOULU
10. **IEEE ASILOMAR Conference [7]**, 7th – 10th November 2010 (Pacific Grove, USA)
Title: “A Self-Organizing Solution for Interference Avoidance in TDD Underlay Femtocells”
Authors: F. Pantisano, M. Bennis, K. Ghaboosi and M. Latva-aho
BeFEMTO partner: UOULU
11. **IEEE ASILOMAR Conference [7]**, 7th – 10th November 2010 (Pacific Grove, USA)
Title: “A Stochastic Association Mechanism for Macro-to-Femtocell Handover”
Authors: C. H. M. de Lima, K. Ghaboosi, M. Bennis, A. Mackenzie and M. Latva-aho
BeFEMTO partner: UOULU
12. **IEEE ASILOMAR Conference [7]**, 7th – 10th November 2010 (Pacific Grove, USA)
Title: “Joint Admission Control and Interference Avoidance in Self-Organized Femtocells”
Authors: C. H. M. de Lima, K. Ghaboosi, M. Bennis, A. Mackenzie and M. Latva-aho
BeFEMTO partner: UOULU
13. **GLOBECOM 2010 Conference [8]**, 6th – 10th December 2010 (Miami, Florida, USA)
Title: “Cognition and Docition in OFDMA-Based Femtocell Networks”
Authors: Ana María Galindo, Lorenza Giupponi and Mischa Dohler
BeFEMTO partner: CTTC
14. **GLOBECOM 2010 FEMNET Workshop [8]**, 6th – 10th December 2010 (Miami, Florida, USA)
Title: “On Interference Analysis of Self-Organized Femtocells in Indoor Deployment”
Authors: C. H. M. de Lima, M. Bennis, K. Ghaboosi and M. Latva-aho
BeFEMTO partner: UOULU
15. **WIRELESS VITAE Conference [9]**, 28th Feb – 03rd Mar 2011 (Le Royal Meridien Chennai, India). Special session on "Advances in Wireless Radio Technologies: IMT-A and beyond".
Title: “Interference Management in Self-Organized Femtocell Networks: the BeFEMTO approach” (joint paper on BeFEMTO activities)
Authors: M. Bennis, L. Giupponi, E. M. Diaz, M. Lalam, M. Maqbool, E. C. Strinati, A. D. Domenico and M. Latva-aho
BeFEMTO partners: UOULU, TID, CTTC, CEA and SC
16. **ICST Simutools Workshop on Ns-3 2011 [10]**, 25th March 2011 (Barcelona, Spain)
Title: “Design, Implementation, and Tracing of Backpressure Routing for WMNs”
Authors: J. Núñez-Martínez and J. Manges-Bafalluy
BeFEMTO partner: CTTC
17. **IEEE WCNC Conference [11]**, 28th -31th March 2011 (Cancun, Mexico)
Title: “Ghost Femtocells: a Novel Radio Resource Management Scheme for OFDMA Based Networks”
Authors: A.de Domenico, E.Calvanese Strinati and A.Duda
BeFEMTO partner: CEA
18. **IEEE WCNC Conference [11]**, 28th -31th March 2011 (Cancun, Mexico)
Title: “Coalition Formation Games for Femtocell Interference Management: A Recursive Core Approach”
Authors: F. Pantisano, M. Bennis, W. Saad, R. Verdone and M. Latva-aho
BeFEMTO partner: UOULU
19. **IEEE WCNC Conference [11]**, 28th -31th March 2011 (Cancun, Mexico)
Title: “Downlink Femto-to-Macro Control Channel Interference for LTE”
Authors: Zubin Bharucha, Gunther Auer and Tetsushi Abe
BeFEMTO partner: DOCOMO

- 20. IOFC' 2011 Third IEEE International workshop on Indoor and Outdoor Femto Cells [12]**, 13th May 2011 (Princeton, USA)
Title: “Downlink Femto-to-Macro Interference Management based on Fuzzy Q-Learning”
Authors: A. Galindo and L. Giupponi
BeFEMTO partner: CTTC This paper received the best paper award in this workshop.
- 21. IEEE VTC2011-Spring BeFEMTO Workshop 2011 [13]**, 15th May 2011 (Budapest, Hungary)
Title: “Interference Management in Femtocell Networks Using Distributed Opportunistic Cooperation”
Authors: F. Pantisano, M. Bennis, R. Verdone and M. Latva-aho
BeFEMTO partner: UOULU
- 22. IEEE VTC2011-Spring BeFEMTO Workshop 2011 [13]**, 15th May 2011 (Budapest, Hungary)
Title: “Graph-Based Dynamic Frequency Reuse in Femtocell Networks”
Authors: Serkan Uygungelen, Gunther Auer and Zubin Bharucha
BeFEMTO partner: DOCOMO
- 23. IEEE VTC2011-Spring BeFEMTO Workshop 2011 [13]**, 15th May 2011 (Budapest, Hungary)
Title: “Localization of Data and Control Plane Traffic in Enterprise Femtocell Networks”
Authors: F. A. Zdarsky, A. Maeder, S. Al-Sabea, and S. Schmid
BeFEMTO partner: NEC
- 24. IEEE VTC2011-Spring BeFEMTO Workshop 2011 [13]**, 15th May 2011 (Budapest, Hungary)
Title: “On Stateless Routing for an All-wireless Network of Femtocells. Implications in the 3GPP Architecture”
Authors: J. Núñez-Martínez, J. Ferragut and J. Mangues-Bafalluy
BeFEMTO partner: CTTC
- 25. IEEE VTC2011-Spring BeFEMTO Workshop 2011 [13]**, 15th May 2011 (Budapest, Hungary)
Title: “Use Cases, Enablers and Requirements for Evolved Femtocells”
Authors: Alexander Tyrrell, Frank Zdarsky, Emilio Mino and Mariano Lopez
BeFEMTO partner: DOCOMO, NEC, TID and TTI
- 26. IEEE VTC2011-Spring BeFEMTO Workshop 2011 [13]**, 15th May 2011 (Budapest, Hungary)
Title: “Flexible Soft Frequency Reuse schemes for heterogeneous networks (macrocell and femtocell)”
Authors: Chrysovalantis Kosta, Ali Imran, Atta U. Quddus and Rahim Tafazolli
BeFEMTO partner: UniS
- 27. IEEE VTC2011-Spring BeFEMTO Workshop 2011 [13]**, 15th May 2011 (Budapest, Hungary)
Title: “Opportunistic Spectrum Reuse for Femtocell Networks”
Authors: Mehrdad Shariat, Atta U. Quddus and Rahim Tafazolli
BeFEMTO partner: UniS
- 28. IEEE VTC2011-Spring BeFEMTO Workshop 2011 [13]**, 15th May 2011 (Budapest, Hungary)
Title: “Distributed Femto-to-Macro Interference Management in Multiuser OFDMA Networks”
Authors: A. Galindo, L. Giupponi and G. Auer
BeFEMTO partner: CTTC
- 29. IEEE International Conference on Communications (ICC) [14]**, 5th -9th June 2011 (Kioto, Japan)
Title: “Decentralized Cross-Tier Interference Mitigation in Cognitive Femtocell Networks”
Authors: M. Bennis and S. M. Perlaza
BeFEMTO partner: UOULU
- 30. Future Network and MobileSummit 2011 Conference [15]**, 15th -17th June 2011 (Warsaw, Poland)
Title: “A Femtocell Business Model: the BeFEMTO View”
Authors: J. B. Vezin, L. Giupponi, A. Tyrrell, E. Mino and M. Miroslaw
BeFEMTO partner: SC, CTTC, DOCOMO, TID and PTC

- 31. Future Network and MobileSummit 2011 Conference [15]**, 15th -17th June 2011 (Warsaw, Poland)
Title: “Models for Interference Avoidance Technique”
Authors: Masood Maqbool, Massinissa Lalam and Thierry Lestable
BeFEMTO partner: SC
- 32. Future Network and MobileSummit 2011 Conference [15]**, 15th -17th June 2011 (Warsaw, Poland)
Title: “Adaptive Downlink Power Control for HSDPA Femtocells”
Authors: Massinissa Lalam, Ioannis Papathanasiou, Masood Maqbool and Thierry Lestable
BeFEMTO partner: SC
- 33. IEEE PIMRC 2011 Conference [6]**, 12th September 2011 (Toronto, Canada)
Title: “On the Analysis of Co-tier Interference in Femtocells”
Authors: Emmanouil Pateromichelakis, Mehrdad Shariat, Atta ul Quddus and Rahim Tafazolli
BeFEMTO partner: UniS
- 34. IEEE PIMRC 2011 Conference [6]**, 12th September 2011 (Toronto, Canada)
Title: “Towards Distributed and Dynamic Backpressure Routing for Wireless Mesh Networks”
Authors: J. Núñez-Martínez, J. Manges-Bafalluy and M. Portoles-Comeras
BeFEMTO partner: CTTC
- 35. IFIP Wireless Days 2011 [16]**, 12th October 2011 (Ontario, Canada)
Title: “An E-Model Based Adaptation Algorithm for AMR voice Calls”
Authors: J. Fitzpatrick
BeFEMTO partner: NEC
- 36. NetGCooP 2011 International Conference on NETwork Games, COnTrol and OPTimization [17]**, 12th-14th October 2011 (Paris, France)
Title: “Femtocell Systems with Self Organization Capabilities”
Authors: A. Galindo and L. Giupponi
BeFEMTO partner: CTTC
- 37. IEEE MASS 2011 Workshop on Enabling Technologies and Standards for Mesh Networks [18]**, 17th October 2011 (Valencia, Spain)
Title: “Studying Practical Any-to-any Backpressure Routing in WiFi Mesh from Lyapunov Optimization Perspective”
Authors: J. Núñez-Martínez, J. Manges-Bafalluy and M. Portoles-Comeras
BeFEMTO partner: CTTC
- 38. COGART 2011 [19]**, 26-29th October 2011 (Barcelona, Spain)
Title: “Small cells, wireless backhaul and renewable energy: a solution for disaster aftermath communications”
Authors: N. Baldo, P. Dini, J. Manges, M. Miozzo and J. Núñez
BeFEMTO partner: CTTC
- 39. IEEE International Symposium on Wireless Communication Systems 2011 [20]**, 7th -9th November 2011 (Aachen, Germany)
Title: “Application of Coordinated Beam Selection in Heterogeneous LTE-Advanced Networks”
Authors: Jochen Giese, M. Awais Amin and Stefan Brueck
BeFEMTO partner: QC
- 40. IEEE GLOBECOM 2011 Conference [21]**, 5th -9th December 2011 (Houston, Texas, USA)
Title: “Cooperative interference alignment in femtocell networks”
Authors: F.Pantisano, M. Bennis, W. Saad and M. Debbah
BeFEMTO partner: UOULU
- 41. IEEE GLOBECOM 2011 Conference [21]**, 5th -9th December 2011 (Houston, Texas, USA)
Title: “Distributed Learning Strategies for Interference Mitigation in Femtocell Networks”
Authors: M.Bennis, S. Guruacharya and D. Niyato

BeFEMTO partner: UOULU

42. **IEEE GLOBECOM 2011 Conference [21]**, 5th-9th December 2011 (Houston, Texas, USA)
Title: "Coordination Mechanisms for Stand-Alone Femtocells in Self-Organizing Deployments"
Authors: C. Lima, M. Bennis and M. Latva-aho
BeFEMTO partner: UOULU
43. **IEEE GLOBECOM 2011 Conference [21]**, 5th-9th December 2011 (Houston, Texas, USA)
Title: "Decentralized Interference Coordination via Autonomus Component Carrier Assignment"
Authors: Serkan Uygungelen, Zubin Bharucha and Gunther Auer
BeFEMTO partner: DOCOMO
44. **IEEE GLOBECOM 2011 [21], Workshop on Mobile Computing and Emerging Communication Networks**, 5th-9th December 2011 (Houston, Texas, USA)
Title: "Distributed Spectral Efficiency Optimization At Hotspots Through Self Organisation of BS Tilts"
Authors: Ali Imran, Muhammad Ali Imran, Atta ul Quddus and Rahim Tafazolli
BeFEMTO partner: UniS
45. **IEEE GLOBECOM 2011 [21], Second Workshop on Femtocell Networks (FEMnet)**, 5th-9th December 2011 (Houston, Texas, USA)
Title: "On Implementation Requirements and Performances of Q-Learning for Self-Organized Femtocells"
Authors: A. Galindo, L. Giupponi and M. Majoral
BeFEMTO partner: CTTC
46. **IEEE ANTS 2011 [22]**, 18th-21th December 2011 (Bangalore, India)
Title: "Radio Resource Management in Femtocell Downlink Exploiting Location"
Authors: R.Mahapatra and E. Calvanese Strinati
BeFEMTO partner: CEA
47. **IEEE CCNC 2012 Conference [23]**, 17th January 2012 (Las Vegas, Nevada, USA)
Title: "A QoS based call admission control and resource allocation mechanism for LTE femtocell deployment"
Authors: J. Fitzpatrick
BeFEMTO partner: NEC
48. **IEEE WCNC 2012 BeFEMTO Workshop [24]**, 8th April 2012 (Paris, France)
Title: "Enabling Macrocell-Femtocell Coexistence through Interference Draining"
Authors: F. Pantisano, M. Bennis, W. Saad, M. Latva-aho and R. Verdone
BeFEMTO partner: UOULU
49. **IEEE WCNC 2012 BeFEMTO Workshop [24]**, 8th April 2012 (Paris, France)
Title: "Dynamic Graph-based Multi-cell Scheduling for Femtocell Networks"
Authors: Emmanouil Pateromichelakis, Mehrdad Shariat, Atta ul Quddus, Rahim Tafazolli
BeFEMTO partner: UniS
50. **IEEE WCNC 2012 BeFEMTO Workshop [24]**, 8th April 2012 (Paris, France)
Title: "Use of Learning, Game Theory and Optimization as Biomimetic Approaches for Self-Organization in Macro-Femtocell Coexistence"
Authors: Ali Imran, Mehdi Bennis, Lorenza Giupponi
BeFEMTO partners: UniS, UOULU and CTTC
51. **IEEE Wiopt 2012 [25]**, 14th May 2012 (Paderborn, Germany)
Title: "Enabling Relaying over Heterogeneous backhuals in the Uplink of Femtocell Networks"
Authors: S. Samarakoon, M. Bennis, W. Saad and M. Latva-aho
BeFEMTO partner: UOULU
52. **IEEE ICC 2012 [26]**, 10-15th June 2012 (Ottawa, Canada)
Title: "Learning coarse correlated equilibria in two tier networks"
Authors: M. Bennis, S. M. Perlaza and M. Debbah

BeFEMTO partner: UOULU

53. **IEEE ICC 2012 [26]**, 10-15th June 2012 (Ottawa, Canada)
Title: "On the Impact of the Heterogeneous Backhaul on Cooperation in Femtocell Networks"
Authors: F. Pantisano, M. Bennis, W. Saad, M. Debbah, and M. Latva-aho
BeFEMTO partner: UOULU
54. **IEEE ICC 2012 [26]**, 10-15th June 2012 (Ottawa, Canada)
Title: "A Self-Organized Tracking Area List Mechanism for Large-Scale Networks of Femtocells"
Authors: Jaime Ferragut and Josep Mangles-Bafalluy
BeFEMTO partner: CTTC
55. **ICL GNSS 2012 [27]**, 25-27th June 2012 (Starnberg, Germany)
Title: "Position Location of LTE Femtocells Deployed in a Cluster"
Authors: M. Awais Amin and Sven Fischer
BeFEMTO partner: QC
56. **IEEE VTC 2012 fall [28]**, 3-6th September 2012 (Québec, Canada)
Title: "A Dynamic Resource Assignment Method for Uncoordinated Wireless Networks"
Authors: Serkan Uygungelen and Zubin Bharucha
BeFEMTO partner: DOCOMO
57. **IEEE PIMRC 2012 [29]**, 9-12th September 2012 (Sydney, Australia)
Title: "A Low-Complexity Distributed Inter-Cell Interference Coordination (ICIC) Scheme for Emerging Multi-cell HetNets"
Authors: Chrysovalantis Kosta, Bernard Hunt, Atta U. Quddus and Rahim Tafazolli
BeFEMTO partner: UniS
58. **IEEE PIMRC 2012 [29]**, 9-12th September 2012 (Sydney, Australia)
Title: "HetNet-based Power Strategies for Femtocell Clusters"
Authors: Massinissa Lalam, Thierry Lestable, Masood Maqbool
BeFEMTO partner: SC
59. **IEEE PIMRC 2012 [29]**, 9-12th September 2012 (Sydney, Australia)
Title: "Control Region Protection in LTE-A Networks"
Authors: Serkan Uygungelen, Zubin Bharucha and Hidekazu Taoka
BeFEMTO partner: DOCOMO

3.2.2 Journals and Magazines

The consortium has presented **10** articles in international journals and magazines like "Connect-World", "Computer Communications", IEEE ComSoc MMTC E-Letters", "IEEE Communications Surveys & Tutorials", "JSAC Femtocells", "IEEE TWC", etc. , as part as the dissemination activities planned for spread of knowledge in the project.

The following list shows a detailed description of the journals and magazines involved in BeFEMTO dissemination activities.

1. Article: "Femtocells femtocell a promise for mobile users and operators"
European magazine: "**Connect-World**" [30] Article n°: 8
Authors: Dr. Heinrich J. Stüttgen, Dr. Stefan Schmid and Dr. Joerg Swetina
BeFEMTO partner: NEC.
2. Article: "From Cognition To Docition: The Teaching Radio Paradigm For Distributed & Autonomous Deployments"
Journal: "**Computer Communications**" [31] Elsevier, August 2010
Authors: L. Giupponi, A. M. Galindo and M. Dohler
BeFEMTO partner: CTTC
3. Article: "Next Generation Femtocells: An Enabler for High Efficiency Multimedia"
Journal: "**IEEE ComSoc MMTC E-Letters**" [32] Vol 5, No 5, September 2010

Authors: A. Quddus, T. Guo, M. Shariat, B. Hunt, A. Imran and Y Ko and R. Tafazolli
BeFEMTO partner: University of Surrey

4. Article: "A Game Theory and Femtocell Communications: Making Network Deployment Feasible "
Journal: **"IGI Global: Femtocell Communications: Business Opportunities and Deployment Challenges"**, April 2011
Authors: M. Bennis, S. M. Perlaza and M. Debbah,
BeFEMTO partner: UOULU
5. Article: "A Survey on MAC strategies for Cognitive Radio Networks"
Journal: **"IEEE Communication Surveys and Tutorials" [33]**
Authors: Antonio De Domenico, Emilio Calvanese Strinati and Maria-Gabriella Di Benedetto
BeFEMTO partner: CEA
6. Article: "Spectrum leasing towards UL macrocell femtocell cooperation"
Journal: **"JSAC Femtocells" [34]**
Authors: F. Pantisano, M. Bennis, W. Saad and M. Debbah
BeFEMTO partner: UOULU
7. Article: "Relay Station Access Link Spectral Efficiency Optimization through SO of Macro BS Tilts)
Journal: **IEEE Communications Letters**
Authors: A. Imran, M. A. Imran, R.Tafazolli
BeFEMTO partner: UniS
8. Article: "A Survey of Self Organisation in Future Cellular Networks"
Journal: **"IEEE Surveys & Tutorials" [33]**
Authors: O. G. Aliu, A. Imran, M. A. Imran and B.Evans
BeFEMTO partner: UniS
9. Article: "On the Evolution of multi-cell Scheduling in 3GPP LTE/LTE-A"
Journal: **IEEE Surveys & Tutorials**
Authors: E. Pateromichelakis, M. Shariat, A. U. Quddus, R. Tafazolli
BeFEMTO partner: UniS
10. Article: "Coordination Mechanisms for Self-Organizing Femtocells in Two-Tier Coexistence Scenarios "
Journal: **"IEEE-TWC" [35]**
Authors: C. H. Lima, M. Bennis and M. Latva-aho
BeFEMTO partner: UOULU

Furthermore, for completing this international action, **two (2)** Journals' Special Issues have been agreed:

1. Special Issue on "Cooperative and Networked Femtocells"
Journal: **ACM/Springer Mobile Networks and Applications (MONET) Journal**
Authors: M. Dohler
BeFEMTO partner: CTTC
2. Special Issue on "Femtocells in 4G Systems"
Journal: **EURASIP Journal**
Authors/Editors: T.Lestable, J.Vidal, S.Barbarossa
BeFEMTO partner: SC – Cooperation with **FP7 Freedom**

3.2.3 Books

The project includes the edition of **two books** on LTE-A Femto technologies developed in BeFEMTO. Its primary audience will be R&D teams in telecommunications, researchers and advanced level students, but also Business Development & Marketing people to understand more the advantages of Femtocell technologies and their state of Art.

The tentative book title is “**4G and Beyond Femto Networks: On the road to Small Cells and Smart Heterogeneous Networks**”, and its writing is expected for the second half of 2012.

The provisional table of contents will follow the next structure:

1. Introduction
2. Market & Industry ecosystem
3. Standardization overview
4. Business Models, Use cases & scenarios
5. System Architecture
6. Evaluation Methodology & Simulation
7. RF Front-End and BB processing
8. Interference Management
9. RRM
10. Self-Organizing Enablers
11. Green Femtos/Energy Efficiency Issues (invited chapter)
12. Traffic management
13. Mobility Management
14. Access Control, Security
15. Multi-Radio Femtocells
16. Backhaul
17. Management System
18. Proof of Concept
19. Conclusions & perspectives

The main book editors are Dr. Thierry Lestable (SAGEMCOM SAS, France), Dr. Frank Zdarsky (NEC Europe Ltd.), Prof. Rahim Tafazolli (University of Surrey, UK), Prof. Matti Latva-aho (University of Oulu, Finland), and Dr. Mehdi Bennis (University of Oulu, Finland), meanwhile the chapter editors are Thierry Lestable, Frank Zdarsky, Mischa Dohler, Mehdi Bennis, Massinissa Lalam, Mariano López, Josep Mangués-Bafalluy and Emilio Calvanese Strinati.

The proposed book title, the table of contents, list of editors, etc. have been sent to the publishing company Wiley. It is estimated to finish the manuscript six months after completion of the BeFEMTO project (July 2012) and ideally to be published by January 2013.

On the other hand, BeFEMTO has also taken part in other books with the edition of some chapters:

1. Book chapter.
Chapter title: “Deployment, PHY techniques, and resource management”.
Book title “**Femtocells networks: on game theory and reinforcement learning mechanisms**”.
Cambridge University Pres, April 2011
Authors: M. Bennis, T. alpcan and D. Niyato
BeFEMTO partner: UOULU
2. Book chapter.
Chapter title: “Decentralized Reinforcement Learning Techniques for Interference Management in Heterogeneous Networks”.
Cambridge 2012, book chapter on **Femtocell Networks: Deployment, PHY Techniques, and Resource Management**
Authors: M. Bennis, D. Niyato and T. Alpcan
BeFEMTO partner: UOULU
3. Book chapter.
Chapter title: “Cognitive Strategies for Green Two-Tier Cellular Networks: A Critical Overview”.
Handbook on Green Information & Communication Systems Elsevier
Authors: Antonio De Domenico, Emilio Calvanese Strinati, and Maria-Gabriella Di Benedetto
BeFEMTO partner: CEA
4. Book chapter.

Chapter title: “**Distributed location management for generalized HetNets. The all-wireless networks of femtocells case study**”

Authors: Josep Mangues-Bafalluy, Jaime Ferragut, Manuel Requena-Esteso,
BeFEMTO partner: CTTC

3.2.4 Presentations at events

BeFEMTO partners have attended to several events where the project goals, partners and scientific knowledge have been presented. The list of these events is given hereafter, highlighting those **23 international presentations**:

1. **Future Networks 5th FP7 Concertation Plenary Meeting (Brussels, Belgium) [36]**, 27th January 2010. BeFEMTO was invited to present its aims and main achievements expected during the project lifetime in the "Future Networks 5th FP7 Concertation Plenary Meeting: Call 4 Projects". The BeFEMTO project also identifies and presents the milestone areas for which the support of, and the cooperation with other projects in the network community would benefit it and where it will bring its expertise to the rest of the network community.
BeFEMTO partner: NEC (TM)
2. **Femto Forum (Singapore) [37]**, 10-12th March 2010. BeFEMTO attended to the plenary session at the Femto Forum.
BeFEMTO partner: SC (PM)
3. **CWiND (Luton, UK) [38]**, 21st June 2010. One BeFEMTO partner was a guest speaker during the femtocell workshop in June. The area of knowledge was about “Networked Femtos: BeFEMTO’s Vision of High-Capacity Green Data Bundles”.
BeFEMTO partner: CTTC
4. **Femto Forum Sep 2010 (San Francisco, USA) [37]**, 28th September – 1st October 2010. BeFEMTO attended the Femto Forum Plenary Meeting in San Francisco, and was invited to present the overall project during a joint session LTE / WG2 (Radio).
BeFEMTO partner: SC (PM)
5. **3rd Japan-EU Symposium (Tampere, Finland) [39]**, 20th October 2010. BeFEMTO attended at 3rd Japan-EU Symposium on the "New Generation Network" and the "Future Internet". Japanese people expressed their interest in some joint proposal for FP8. Finally, during the symposium, there was quite a lot of interest in CWC (cognitive wireless clouds) and Smart Grids.
BeFEMTO partner: UOULU
6. **3rd International Workshop on Femtocells (Luton, UK), 24th January 2011.**
BeFEMTO partner: CTTC
7. **Canada-EU Future Internet Workshop (Waterloo, Canada) [40]**, 23rd March 2011.
BeFEMTO partner: SC (PM)
8. **GdR ISIS - Telecom Paris Tech (Paris, France) [41]**, 8th April 2011. One BeFEMTO partner was a guest speaker during this event, presenting BEFEMTO concepts.
BeFEMTO partner: SC (PM)
9. **4th Workshop on Femtocells King's College (London, UK) [42]**, 22nd June 2011. Two BeFEMTO partner were invited speakers during this event, presenting BEFEMTO advances.
BeFEMTO partner: SC (PM) and DOCOMO.
10. **4th Workshop on Femtocells King's College (London, UK) [42]**, 22nd June 2011. Two BeFEMTO partner were invited speakers during this event, presenting BEFEMTO advances.
BeFEMTO partner: CEA.
11. **13th LETI Annual Review (MINATEC, Grenoble, France) [43]**, 27th -28th June 2011. One BeFEMTO partner gave a presentation of BeFEMTO results.
BeFEMTO partner: CEA.

12. **First International Summer School on Cognitive Wireless Communications (COST IC0902 & NoE ACROPOLIS) (Florence, Italy) [44]**, 12–15th July, 2011.
Poster presentation: Antonio de Domenico
BeFEMTO partner: CEA
13. **IEEE International Symposium on Wireless Communication Systems**. 7th -9th November 2011. One BeFEMTO partner was invited speaker in the session on industry topics presenting Heterogeneous Networks in 3GPP LTE-Advanced.
BeFEMTO partner: QC
14. **Joint BeFEMTO & FREEDOM Femto Winter School [45], "Femto LTE-A Hardware Design Challenges" (Barcelona, Spain)**, 6-10th February 2012
Guest speaker: Mariano López
BeFEMTO partner: TTI
15. **Joint BeFEMTO & FREEDOM Femto Winter School [45], "Cognitive & Dognitive Femtocell Networks" (Barcelona, Spain)**, 6-10th February 2012
Guest speaker: Ana Galindo-Serrano
BeFEMTO partner: CTTC
16. **Joint BeFEMTO & FREEDOM Femto Winter School [45], "LTE/LTE-A SON for Femtocells" (Barcelona, Spain)**, 6-10th February 2012
Guest speaker: Mischa Dohler
BeFEMTO partner: CTTC
17. **Joint BeFEMTO & FREEDOM Femto Winter School [45], "Overview of the BeFEMTO Networking Architecture" (Barcelona, Spain)**, 6-10th February 2012
Guest speaker: Josep Mangués-Bafalluy
BeFEMTO partner: CTTC
18. **Joint BeFEMTO & FREEDOM Femto Winter School [45], "Local Location Management in Networks of Femtocells" (Barcelona, Spain)**, 6-10th February 2012
Guest speaker: Jaime Ferragut
BeFEMTO partner: CTTC
19. **Joint BeFEMTO & FREEDOM Femto Winter School [45], "Distributed Routing in All-Wireless Networks of Femtocells" (Barcelona, Spain)**, 6-10th February 2012
Guest speaker: José Núñez-Martínez
BeFEMTO partner: CTTC
20. **Joint BeFEMTO & FREEDOM Femto Winter School [45], "All-Wireless Network of Femtocells Testbed: Distributed Routing" (Barcelona, Spain)**, 6-10th February 2012
Guest speaker: José Núñez-Martínez
BeFEMTO partner: CTTC
21. **5th King's College Workshop on Femtocells (and HetNets) (London, UK) [46], "Performance Evaluation of LTE MIMO Femto HetNets with Interference Mitigation"**, 14th February 2012.
Guest speaker: Masood Maqbool
BeFEMTO partner: SC
22. **5th King's College Workshop on Femtocells (and HetNets) (London, UK) [46], "Self Organization in distributed systems: A practical application in femtocell networks"**, 14th February 2012.
Guest speaker: Ana Galindo-Serrano
BeFEMTO partner: CTTC
23. **LTE World Summit**, May 2012, Barcelona
Guest speaker: Josep Mangués-Bafalluy
BeFEMTO partner: CTTC

3.2.5 Plenary meetings and annual meeting with project's Advisory Board

As part of the internal dissemination and BeFEMTO cooperation among the partners, BeFEMTO has organized internal or plenary meetings and conference calls. These meetings have been used (and will be used) as support for the good functioning and sharing of information and vision over the BeFEMTO work during the phases of the project development.

1. **BeFEMTO Kick-off Meeting**, 18th -19th January 2010. The Kick-Off Meeting of BeFEMTO project was hosted in Sagemcom's HQ, Paris, France.
2. **BeFEMTO 2nd General Assembly**, 16th -17th September 2010. The 2nd General Assembly of BeFEMTO was hosted in CTTC, Barcelona, Spain.
3. **BeFEMTO 3rd General Assembly**, 1st - 2nd December 2010. The 3rd General Assembly of BeFEMTO was hosted in the University of Surrey (UniS), Guildford, UK.
4. **BeFEMTO Kick-Off meeting with Advisory Board**, 3rd December 2010. This jointly meeting between the BeFEMTO Board members and Advisory Board members of several key organizations, was hosted in the University of Surrey (UniS), Guildford, UK. The Advisory Board members present at this meeting were the following:
 - William Webb (OfCOM)
 - Mariusz Busillo (UKE)
 - Jean-Philippe Kermaol (ECO)
 - Simon Saunders (Femto Forum)
 - Frederic Pujol (IDATE)

In the meeting, BeFEMTO presented the activities and results obtained during the first project year to the AB members. After fruitful discussions and interest by the AB members for the BeFEMTO presentation, each AB member presented its point of view in several aspects of interest of BeFEMTO. Among others, several topics were discussed:

- Interference management
 - LTE market
 - FemtoForum contribution: for academic research institutions, the best way is to contribute via a FemtoForum member
 - Spectrum issues: LTE Spectrum Fragmentation Risk, Digital dividend or LTE Mobile Operator Strategy, currently LTE deployment bands
 - Regulatory issues for femtocells: not regulatory issues currently, only power limitations (20dBm)
 - No expected license needed to operate femtocells (only spectrum license)
 - Several questions to be answered by BeFEMTO for submission to CEPT and ECO, like:
 - Sharing scenario envisaged by BeFEMTO
 - Technical characteristics for transmitter and receiver
 - Topology envisaged (Network or single configuration)
 - Interference scenario as victim and interferer
 - Propagation model
 - Interference mitigation techniques
 - Inputs and outputs between BeFEMTO and these organizations
5. **BeFEMTO 4th General Assembly**, 6th – 7th April 2011. The 4th General Assembly of BeFEMTO was hosted in CEA-LETI, Grenoble, France.
 6. **BeFEMTO 5th General Assembly**, 8th – 9th September 2011. BeFEMTO 5th General Assembly was hosted successfully in NEC Laboratories Europe, Heidelberg, Germany. The meeting was attended by all the partners involved in the project.
 7. **BeFEMTO 6th General Assembly**, 30th November – 1st December 2011. BeFEMTO 6th General Assembly was hosted successfully in Telefónica I+D, Madrid, Spain. All the partners involved in the project attended the meeting.
 8. **BeFEMTO 7th General Assembly**, 20th – 21st March 2012. BeFEMTO 7th General Assembly was hosted successfully in SAGEMCOM, Paris, France. The meeting obtained fruitful results.

9. **BeFEMTO 8th General Assembly**, 20th – 21st June 2012. BeFEMTO 8th General Assembly was hosted successfully by mimoOn, Duisburg, Germany

3.2.6 Organization and sponsorship of events

This section covers the BeFEMTO dissemination results related to the organization of **five international workshops, one panel session and two training schools**. These events increased the international visibility of the BeFEMTO project and collaborative exchange of information between the organizers and the attendees.

3.2.6.1 International Workshops and panel sessions

BeFEMTO has organized **five International Workshops (during VTC Spring 2011, FUNEMS 2011, WNCN 2012, ICC 2012 and ICCCN 2012)** with the great background support of academic partners in the Consortium. These workshops included papers presentations, international keynote speakers and **panel discussion**, with high interest to both scientific point of view and economic interest from industry involved in femtocells. Workshops highlighted the maturity of technologies, attractively of services, business and low risk for operators. BeFEMTO partners have contributed with some papers to these workshops.

On the other hand, BeFEMTO has chaired a **Panel Session** on 'Femto/WiFi' in **IEEE PIMRC 2011** conference, Toronto, Canada, where representatives from Telefónica, InterDigital, Mitsubishi Electric Research Center, University of Oulu, and University of Surrey debated their vision, understanding and benefits of such interworking between two of most promising offloading technologies, within the context of Heterogeneous Networks (HetNets).

A short description of these events is shown below and more detailed information is given in the following sections:

- 1st Workshop organized: International Workshop “Broadband evolved Femtocell Technologies. ‘Key’ to Next Generation of Mobile Internet” @ VTC 2011 spring (Budapest, Hungary).
The first international workshop by BeFEMTO was organized mid-May 2011 during the IEEE VTC Spring 2011 [47], located in Budapest (Hungary), under the name of “Broadband evolved Femtocell Technologies (BeFEMTO)”. VTC2011-Spring BeFEMTO Workshop provided invaluable opportunities for researchers and industry practitioners to share their state-of-the-art research and development results on specific areas or challenging topics.
- 2nd Workshop organized: International Workshop “European Workshop on Broadband Femtocell Networks” @ FuNEMS 2011 (Warsaw, Poland).
The second international workshop was organized jointly by BeFEMTO and Freedom project during FuNEMS 2011 [48], mid-June 2011 in Warsaw (Poland), for promoting femtocell technologies and key achievements of both projects.
- 3rd Workshop organized: “International Workshop on Broadband Femtocell Technologies - Paving the Way to Heterogeneous Cellular Networks” @ IEEE WCNC 2012 (Paris, France).
This workshop took place the 1st April 2012 [49], during the IEEE WCNC 2012 conference in Paris (France). The workshop has been co-organized with the King’s College of London.
- 4th Workshop organized: “1st International Workshop on Small Cell Wireless Networks (SmallNets)”, BeFEMTO Workshop @ IEEE ICC 2012 (Ottawa, Canada). 11th June 2012 [50]
- 5th Workshop organized: Second Workshop on Cooperative Heterogeneous Networks (coHetNet) in conjunction with ICCCN 2012 . 30/07/2012
- Panel Session: Panel Session “Femtocells & WiFi: Towards Cost efficient Ubiquitous Broadband” @ PIMRC 2011 (Toronto, Canada).

3.2.6.1.1 IEEE VTC2011-Spring: International Workshop on “Broadband evolved Femtocell Technologies (BeFEMTO), ‘Key’ to Next Generation of Mobile Internet”, 15th May 2011 (Budapest, Hungary)

Motivation: Femtocell technologies accelerate the cost effective provision of ubiquitous broadband services by convergence between fixed and wireless broadband. This full day workshop aimed to bring together internationally leading academic and industrial perspectives and thinking to highlight and discuss recent progress in femtocell technologies. The list of promising new developments includes cooperative networks of femtocells and extending the classical concept of indoor femtocells to the outdoors, e.g. as fixed relays in macrocells for enhancing coverage and cell-edge capacity or as mobile femtocells in public transports. Self-organising techniques for high capacity and optimum use of transmit power whilst minimising OPEX and simplifying complexity for remote network management are vitally important to cope with expected multiple million femtocells networks.

Scope and Objectives: In view of current standardization activities in 3GPP and IEEE, changing regulatory landscape and impetus from industrial bodies such as Femto Forum, this workshop focused on presenting and debating advanced femtocell technologies that have the potential to be considered in future standards such as LTE-A to make the radio access solutions highly efficient with major leapfrog in spectral-efficiency per unit area, while minimizing the transmit power. Specifically, but not exclusively, this workshop proposed to address the following issues:

- Optimisation of Radio Access
- New generation of baseband and radio frequency techniques
- Smart interference management
- Self-configuration and self-optimisation techniques
- Network management and architecture
- Field Trials / Test-beds / Regulatory issues

Call for Papers Organization:

In order to spread the CfP of this workshop, BeFEMTO consortium advertised it around its contact lists and in relevant channels of CfP dissemination. The dates handled to organize this Call were the following ones:

- Workshop Paper Submission Deadline: Extended to 30th November 2010. Papers needed to be uploaded to the VTC Trackchair, should was in English, not exceeding 5 double-column pages, and should followed IEEE paper templates. Accepted papers were been published in the IEEE Xplorer. They could be presented either orally or by means of a poster.
- Paper Status Notification: 9th January 2011
- Final paper submission deadline: 20th February 2011
- Workshop: 15th May 2011



Figure 3-1: BeFEMTO CfP Workshop banner @ VTC 2011-Spring



Figure 3-2: BeFEMTO Workshop @ VTC 2011-Spring publicized in the website

The Organising Committee was composed by the following BeFEMTO members:

-
- Chair: Thierry Lestable (SAGEMCOM, France)
 - Co-Chairs: Matti Latva-aho (University of Oulu, Finland), Frank Zdarsky (NEC Europe, Germany) and Atta Quddus (University of Surrey, UK).

The Technical Programme Committee was composed by these members (listed alphabetically):

- Alexander Tyrrell, DOCOMO Eurolabs, Germany
- Atta ul Quddus, University of Surrey, UK
- Carles Anton, CTTC, Spain
- Emilio Calavnese Strinati, CEA-LETI, France
- Emilio Mino Diaz, Telefónica, Spain
- Frederic Geheniau, SAGEMCOM, France
- Gunther Auer, DOCOMO Eurolabs, Germany
- Jean Baptise Vezin, SAGEMCOM, France
- Lorenza Giupponi, CTTC, Spain
- Manuel Palmowski, mimoOn, Germany
- Mariano López, TTI, Spain
- Massinissa Lalam, SAGEMCOM, France
- Mehdi Bennis, University of Oulu, Finland
- Mirosław Brzozowy, PTC, Poland
- Muhammd Imran, University of Surrey, UK
- Stefan Brueck, Qualcomm CDMA Tech., Germany
- Stefan Kaiser, DOCOMO Eurolabs, Germany
- Stefan Schmidt, NEC Europe, Germany
- Sylvie Mayrargue, CEA-LETI, France
- Willem Mulder, mimoOn, Germany

This workshop received **23 paper submissions** which were all peer reviewed by at least 3-reviews per submission and as a result of the review process, **11** submissions were selected for **oral** presentations and **8** for **poster** displays. There were two (2) external **keynote speakers**: Prof. Mérouane Debbah (Head of Alcatel-Lucent) and Frédéric Pujol (Head of Radio Technologies and Spectrum practice in IDATE). A **panel discussion** chaired by BeFEMTO PM, Thierry Lestable, including the two previous keynote speakers, and Dr. Andreas Maeder from NEC Europe was also held attracting great interest from the Audience.

Workshop program:

The full day workshop was divided in five sessions:

1. Opening session, chaired by Dr. Thierry Lestable (PM), SAGEMCOM. This session included the first keynote speaker talk about “Cognitive LTE Small Cell Networks” managed by Prof. Mérouane Debbah, Head of Alcatel-Lucent Flexible Radio Chair in Supélec, and the presentation of 3 papers:
 - “Use Cases, Enablers and Requirements for Evolved Femtocells”, from BeFEMTO WP2. Contribution based on the use cases, femto services and technical features.
 - “LTE-Femtocells: System Design and Performance Analysis”, from QC.
 - “Localization of Data and Control Plane Traffic in Enterprise Femtocell Networks”, from BeFEMTO WP5.
2. Session 2 with 4 papers exposed, chaired by Dr. Mehdi Bennis, University of Oulu;
 - “Experimental Characterization of UMTS Femtocell Propagation”, from University of Bologna and Telecom Italia.
 - “Graph-Based Dynamic Frequency Reuse in Femtocell Networks”, from BeFEMTO WP4.
 - “Distributed Learning in Multiuser OFDMA Femtocell Networks”, from CTTC and DOCOMO Euro-Labs.
 - “Opportunistic Spectrum Reuse for Femtocell Networks”, from BeFEMTO WP3.
3. Posters session, chaired by BeFEMTO PM, where 8 posters were presented:
 - “Interference Management in Femtocell Networks Using Distributed Opportunistic Cooperation”, from BeFEMTO WP4 and the University of Bologna.
 - “Flexible Soft Frequency Reuse schemes for heterogeneous networks (macrocell and femtocell)”, from BeFEMTO WP3.
 - “Alamouti Transmit Diversity for Energy Efficient Femtocells”, from University of Surrey.

- o “Zero-Forcing Coordinated Base Station Transmission for Femtocell Systems”, University Carlos III of Madrid.
 - o “Measurement-Based Small-Cell Coverage Analysis for Urban Macro-Offload Scenarios”, from FTW - Telecommunications Research Centre Vienna, Ivan Gojmerac, FTW - Telecommunications Research Centre Vienna
 - o “Modeling of Femto Cells – Simulation of Interference and Handovers in LTE Networks”, from Braunschweig Technical University.
 - o “New Coordination and Resource Allocation Schemes for Uniform Rate in Femtocell Networks”, Orange Labs, INSA Rennes) and France Telecom R&D.
 - o “Performance Evaluation of Spectrum Sharing Algorithms in Single and Multi Operator Scenarios”, from University of Rome Tor Vergata and Radiolabs.
4. Panel session, chaired by BeFEMTO PM (Thierry Lestable). This session began with the second keynote speaker, Frédéric Pujol, Head of Radio Technologies and Spectrum practice in IDATE, with a talk about “Mobile traffic forecasts 2010-2020 & offloading solutions”. After that, it follows with a Panel Discussion on “Femtocells as Keystone of Heterogeneous Networks, driving the Offload revolution” with these hot topics of interest to be discussed:
- o New features and capabilities of Next Generation (LTE-A and Beyond) Femtocells.
 - o Femtocells Market forecast, business model trends.
 - o Multi-mode Femtocells: benefits for existing Network upgrade & role of Flexible Radio.
 - o Femtocells and WiFi: Complementary approach towards true ubiquitous and quality broadband solution.

Whilst chaired by Dr. Thierry Lestable (Sagemcom SAS), the panel was composed by the following members: Mr. Frédéric Pujol, (IDATE), Prof. Mérouane Debbah, (Supélec), Dr. Andreas Maeder (NEC Europe)..

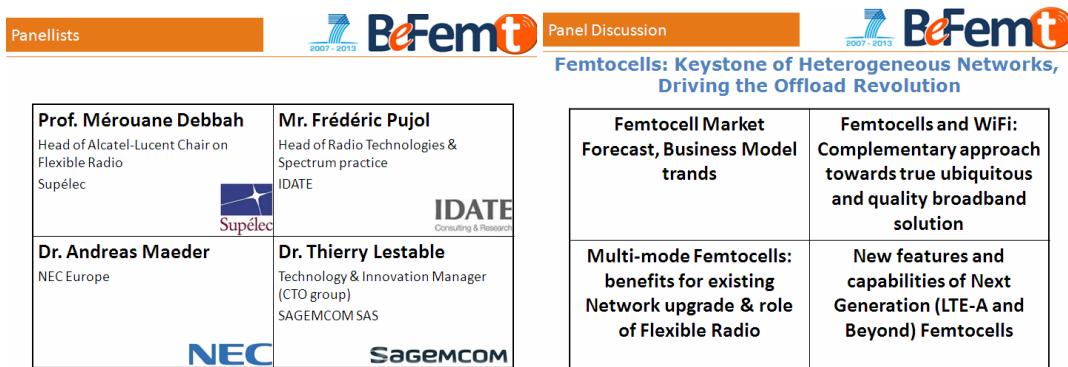

Figure 3-3: BeFEMTO Workshop @ VTC 2011-Spring: Panel Session

5. Final session and Wrap-up, which included 4 papers exposed, chaired by BeFEMTO PM and finalized with a wrap-up and conclusion remarks.
- o “Optimization of Dynamic Frame Offset in Time Division Duplex System”, from Aalto University School of Science and Technology, Helsinki University of Technology and Nokia Research Center.
 - o “A Distributed Resource Allocation Scheme in Femtocell Networks”, from Beijing University of Posts and Telecommunications.
 - o “On Uplink Power Control Optimization and Distributed Resource Allocation in Femtocell Networks”, from Aalto University and Helsinki University of Technology.
 - o “On Stateless Routing for an All-wireless Network of Femtocells. Implications in the 3GPP Architecture”, from BeFEMTO WP5.

Workshop Conclusions:

VTC Spring 2011 BeFEMTO workshop [47] organised by BeFEMTO provided invaluable opportunities for researchers and industry practitioners to share their state-of-the-art research and development results on specific areas or challenging topics. The large number of papers (23) received from a mix of both academic community and key industry members showed the wide scale of interest in femtocells. The success of the VTC workshop prompted and encouraged BeFEMTO partners to further organise and make active contributions in future workshops on femtocells and related technologies, as will be illustrated in next sections.

3.2.6.1.2 ICT Future Network & Mobile Summit (FuNEMS) 2011, European Workshop on “Broadband Femtocell Networks. Towards Ubiquitous High Bitrate Coverage”, 14th June 2011 (Warsaw, Poland)

Motivation: Recent years have witnessed an increasing demand for mobile wireless traffic due to the new types of user terminal and applications. The delivery of high throughput at cell edge, indoor and dead-spots is still a challenge. This has motivated the introduction of femtocells in 3G, LTE and WiMAX networks, initially targeting deployments in residential and corporate environment, to get first better indoor voice and data coverage, whilst offloading at the same time macrocell traffic and thus promising to be a cost-effective solution. Femtocells are called to be an integral part of high-performance next-generation wireless systems, while keeping the seamless connectivity and mobility of conventional cellular networks. This workshop aimed at covering the different technical challenges to which femtocell deployments are confronted.

Scope and Objectives: This workshop, co-located with the Future Networks and Mobile Summit 2011 [48], has been organized thanks to the joint efforts and collaboration of the FP7 European research projects FREEDOM [51] and BeFEMTO [52], both conducting edge research on femtocell-related technologies. The main objectives were to offer an opportunity for academic and industrial researchers for spreading and sharing results and understanding on femtocell networks. Topics of interest included the following ones:

- Interference management and coordination: (e)ICIC
- PHY/MAC layer enhancement techniques
- Cognitive femtocell networks
- Channel and interference models
- Self-organising networks (SON), self-configuration and optimization techniques (e.g. Power setting, Mobility Robustness optimization, Load Balancing)
- Resource allocation techniques (RRM)
- Routing algorithms
- Mobility support
- Network architectures and features (e.g. LIPA, SIPTO, IFOM)
- Trade-offs and benchmarking between femtocells, picocells and relay networks
- Regulatory aspects (e.g. co-existence, new spectrum, lawful interception) and business cases

Best papers were invited to submit a longer version to a EURASIP journal special issue on femtocell networks.

Call for Papers Organization:

In order to disseminate the CfP of this workshop, the BeFEMTO consortium advertised it around its contact lists and in relevant channels of CfP dissemination. The dates handled to organize this Call were the following ones:

- Workshop Paper Submission Deadline: 1st March 2011.
- Paper Status Notification: 21st March 2011.
- Final paper submission deadline: 28th March 2011.
- Workshop: 14th June 2011.



Figure 3-4: BeFEMTO CfP Workshop banner @ FuNEMS 2011



Figure 3-5: BeFEMTO Workshop @ FuNEMS 2011 publicized in the website

The Workshop Chairs were Prof. Josep Vidal (Freedom PM), and Dr. Thierry Lestable (BeFEMTO PM).

The Steering Committee was composed by the following BeFEMTO, and FREEDOM members:

- Stefan Schmid, NEC, Germany
- Sergio Barbarossa, Univ. of Rome, Italy
- Frank Zdarsky, NEC, Germany

The Technical Programme Committee was composed by these members (listed alphabetically):

- A. Agustín, UPC, Spain F.X.
- A. Tyrrell, Docomo Eurolabs, Germany
- A. ul Quddus, Univ. of Surrey, UK
- Ari Wibowo, Telkom, Indonesia
- D. López-Pérez, King's College, UK
- E. de Marinis, DUNE, Italy
- E. Mino Díaz, Telefonica I+D, Spain
- F. Geheniau, SAGEMCOM, France
- G. He, Bell-Labs Shangai, China
- G. Vivier, Sequans, France
- J. Hämäläinen, Aalto University, Finland
- L. Giupponi, CTTC, Spain
- L. Pescosolido, University of Rome, Italy
- M. Bennis, University of Oulu, Finland
- M. Coupechoux, Telecom ParisTech, France
- M. Debbah, Supelec, France
- M. López, TTI, Spain
- P. Roux, CEA-List, France
- Y. Corre, Siradel, France
- Z. Becvar, CTU, Czech Republic

Workshop program:

This workshop included **14 oral presentations** by authors from BeFEMTO WPs and from academic and industrial entities outside the project, **2 keynote speakers**: Prof. Simon Saunders, Chairman of Femto Forum and Rupert Baines, VP Marketing, Picochip Ltd., and **a panel discussion** chaired by BeFEMTO PM (Dr. Thierry Lestable (SAGEMCOM)), supported by FREEDOM PM (Prof. Josep Vidal), including the two previous keynote speakers from Femto Forum and Picochip, together with Emilio Mino (Principal Engineer from Telefónica I+D, BeFEMTO), and Dr. Brzozowy Mirosław (T-Mobile (former PTC), BeFEMTO).

The workshop was divided in four sessions during one day:





1. Opening session, chaired by Dr. Thierry Lestable (BeFEMTO PM, SAGEMCOM) and Prof. Josep Vidal (Freedom PM, UPC). This session included 5 oral presentations with the following titles, representatives of the state of the art in the workshop topics:
 - “Time and Frequency Synchronization Protocol for Femto Networks”, from BeFEMTO partner University of Oulu (Centre for Wireless Communications).
 - “Adaptive Downlink Power Control for HSDPA Femtocells”, from BeFEMTO partner SAGEMCOM, France.

- o “Service-oriented Utility-based Uplink Power Control in Two-Tier Femtocell Networks”, from Institute of Communications and Computer Systems, Greece.
 - o “Femtocell system optimization by genetic algorithm in clustered scenarios”, from Freedom partner Dune Sistemi, Italy.
 - o “Study on Transmission Bearer Mechanisms for e-MBMS in LTE based Femtocells”, from Freedom Project partner Research and Development Center, Telkom Indonesia, Indonesia.
2. Session 2, chaired by Dr. Thierry Lestable (BeFEMTO PM, SAGEMCOM) and Prof. Josep Vidal (Freedom PM, UPC). Five oral presentations were presented by authors from both Freedom and BeFEMTO projects and other organizations like Aalto University, Finland and Technical University of Catalonia, Spain:
- o “A Femtocell Business Model: the BeFEMTO view”, from BeFEMTO project partners SAGEMCOM, CTTC, DOCOMO Euro-Labs, Telefónica R&D and PTC.
 - o “Fast Cell Selection for femtocell based access networks”, from Freedom project partner CEA, France.
 - o “Balancing egoism and altruism in transmit beamforming in femtocells”, from Aalto University, Finland and Technical University of Catalonia, Spain.
 - o “Interference Pricing for Self-organisation in OFDMA Femtocell Networks”, from Freedom partner UPC, Spain.
 - o “Performance of Practical Transmit Beamforming Methods for Interference Suppression in Closed-Access Femtocells”, from Aalto University, Finland.
3. Panel session, chaired by BeFEMTO & Freedom PMs. Similarly as in the former IEEE VTC Spring Workshop, Keynote speakers were followed by a Panel session. The 2 keynote speakers members were: Prof. Simon Saunders, Chairman of Femto Forum, and Rupert Baines, VP Marketing, picochip Ltd. They talked about “Femtocell Market Update & Latest News from Femto Forum”, and “The disruptive future of Femtocells” respectively. After those expositions, a panel discussion was triggered on Femtocells as “Keystone of Heterogeneous Networks, Driving the Offload Revolution” with these hot topics of interest to be discussed:
- o Femtocells Market: status, forecast, business models
 - o Femtocells and WiFi: Complementary approach towards true ubiquitous and quality broadband solution
 - o Key promising features of Next Generation (LTE-A and Beyond) Femtocells
 - o Regulatory aspects of Femtocells: status, requirements, role in coming LTE bidding auctions
 - o Multi-mode Femtocells: benefits for existing Network upgrade & frequency bands turmoil.

The panel was composed by the following members: Prof. Simon Saunders, (Femto Forum) Rupert Baines, (picochip), Dr. Thierry Lestable, (Sagemcom SAS), Prof. Josep Vidal, (UPC), Emilio Mino, (TID), and Brzozowy Mirosław, (PTC, Technology & Innovation Department).

Panellists



<p>Prof. Simon Saunders Chairman of Femto Forum</p> 	<p>Mr. Rupert J. Baines VP Marketing Picochip Ltd & WGI Chair Femto Forum</p> 
<p>Prof. Josep Vidal UPC Spain</p> 	<p>Dr. Thierry Lestable Technology & Innovation Manager (CTO group) SAGEMCOM SAS</p> 
<p>Dr. Mirosław Brzozowy. Coordinator T-Mobile (former PTC) Poland</p>	<p>Emilio Mino Principal Engineer Telefonica I+D, Spain</p>

Panel Discussion



Femtocells: Keystone of Heterogeneous Networks, Driving the Offload Revolution

<p>Femtocell Market Forecast, Business Models & Regulatory aspects (LTE bidding auctions)</p>	<p>Femtocells and WiFi: Complementary approach towards true ubiquitous and quality broadband solution</p>
<p>Multi-mode Femtocells: benefits for existing Network upgrade & role of Flexible Radio</p>	<p>New features and capabilities of Next Generation (LTE-A and Beyond) Femtocells</p>

Figure 3-6: BeFEMTO Workshop @ FuNEMS 2011: Panel Session

4. Session 4, chaired by Dr. Thierry Lestable (BeFEMTO PM, SAGEMCOM) and Prof. Josep Vidal (Freedom PM, UPC). Four (4) oral presentations were handled by authors from Freedom and BeFEMTO projects and Ericsson, Sweden:

- “Comparison of Femto Cell Deployment Models for an Interference Avoidance Technique”, from BeFEMTO project partner SAGEMCOM, France.
- “Pricing mechanisms for interference management games in femtocell networks based on Markov modelling”, from Freedom project partner DIET, University of Rome ‘La Sapienza’, Italy.
- “Home eNodeB Handover Self-Optimisation”, from Ericsson, Sweden.
- “Securing the Backhaul for Mobile and Multi-homed Femtocells”, from CWC, Finland.

This last session was finished by a wrap up and conclusions remarks by the workshop chairs.

3.2.6.1.3 IEEE WCNC 2012, International Workshop on “Broadband Femtocell Technologies – Paving the Way to Heterogeneous Cellular Networks”, 1st April 2012 (Paris, France)

Motivation: Heterogeneous cellular networks (HetNet), in which a large number of low-power nodes such as picocells, femtocells and relay nodes overlay traditional macrocell networks, have been heralded as the most promising way to enhance network performance and meet future customer needs. By deploying more network infrastructures, cellular networks will be made closer to end-users, thus enhancing radio link quality and spatial spectrum reuse in a cost-effective manner. Among the lower-power nodes, femtocells play a key role due to their user-deployed, low-cost, low-power and low electromagnetic (EM) exposure characteristics, as well as their advantages in providing indoor coverage. Hence, femtocell technologies may accelerate the cost-effective provision of ubiquitous broadband services by convergence between fixed and wireless broadband.

This full day workshop aimed to bring together internationally leading academic and industrial perspectives, and discuss recent progress in femtocell technologies. The list of promising new developments includes cooperative networks for interference mitigation in heterogeneous networks made of macro/pico/femto cells, extending the classical concept of indoor femtocells to outdoors, e.g., fixed relays in macrocells for enhancing coverage and cell-edge capacity, mobile femtocells in public transports, and self-organizing (SON) techniques for high capacity and optimum use of transmit power while minimizing OPEX and simplifying complexity for remote network management.

Scope and Objectives:

In view of current standardization activities in 3GPP and IEEE, changing regulatory landscape and impetus from industrial bodies such as Femto Forum, this workshop focuses on presenting and debating advanced femtocell technologies that have the potential to be considered in future standards such as LTE-A to make the radio access solutions highly efficient with major leapfrog in spectral-efficiency per unit area, while minimizing transmit power. Specifically, but not exclusively, the workshop proposes to address the following issues:

- Femtocell network management and architectures
- Closed-access, open-access, and restricted-access
- Self-configuration and self-optimization techniques
- Outdoor femtocells
- Mobile femtocells in transportation services, e.g., buses, trains, airplanes
- Cognitive femtocells
- Cooperative femtocells
- Modelling, simulation and key performance indicators for heterogeneous cellular networks
- Coexistence between macrocell, picocell, relay node and femtocell networks
- Decentralized & distributed smart interference management
- New generation of base-band and radio frequency techniques
- Enhanced inter-cell interference coordination (eICIC) methods
- Mobility management and load balancing among different types of cellular nodes
- Offloading techniques
- Timing synchronization
- Back-hauling solutions
- Field Trials / Test-beds / Regulatory issues
- Power saving mechanisms in heterogeneous cellular networks



Figure 3-7: BeFEMTO Workshop @ WCNC 2012 publicized in the website

Organizers (Chairs):

- Thierry Lestable, SAGEMCOM SAS, France
- Frank Zdarsky, NEC, UK
- David Lopez-Perez, King's College London, UK
- Guillaume de la Roche, University of Bedfordshire, UK

Steering Committee:

- Atta Quddus, Univ. of Surrey, UK
- Xiaoli Chu, King's College London, UK
- Josep Vidal, UPC, Spain
- Mischa Dohler, CTTC, Spain

Workshop program:

09:00 - 10:30

S1: Broadband Femtocell Technologies I: Opening Session

Chair: Thierry Lestable (Sagemcom SAS, France)

Keynote Speech#1: Qualcomm Incorporated

Dino Flore, 3GPP RAN3 Chairman (Qualcomm Inc., USA)

Mobility Enhancements for Heterogeneous Networks through Interference Coordination

David López-Pérez (King's College London, United Kingdom); Ismail Guvenc (DOCOMO Innovations, Inc., USA); Xiaoli Chu (King's College London, United Kingdom)

Macro-Femto Inter-Cell Interference Mitigation for 3GPP LTE-A Downlink

Ming Huang (Technical University Munich & Intel Mobile Communication, P.R. China); Wen Xu (Intel & Intel Mobile Communications, Germany)

11:00 - 12:30

S2: Broadband Femtocell Technologies II

Chair: David López-Pérez (King's College London, United Kingdom)

Enabling Macrocell-Femtocell Coexistence through Interference Draining

Francesco Pantisano (University of Bologna & Centre for Wireless Communications, Finland); Mehdi Bennis (Centre of Wireless Communications, University of Oulu, Finland); Walid Saad (University of Miami, USA); Matti Latva-aho (UoOulu, Finland); Roberto Verdone (University of Bologna, Italy)

A Fully Distributed Method for Dynamic Spectrum Sharing in Femtocells

Gustavo W. O. Costa (Aalborg University, Denmark); Andrea F. Cattoni (Aalborg University, Denmark); Istvan Z. Kovacs (Nokia Siemens Networks, Denmark); Preben Mogensen (Nokia Siemens Networks, Aalborg, Denmark)

Distributed Opportunistic Medium Access Control in Two-Tier Femtocell Networks

Ben Niu (Tsinghua University, P.R. China); Chia-Lin Wu (SUPELEC, Taiwan); Marios Kountouris (Supélec, France); Yunzhou Li (Tsinghua University, P.R. China)

Dynamic Graph-based Multi-cell Scheduling for Femtocell Networks

Emmanouil Pateromichelakis (University of Surrey, United Kingdom); Mehrdad Shariat (University of Surrey, United Kingdom); Atta Ul Quddus (University of Surrey, United Kingdom); Rahim Tafazolli (University of Surrey, United Kingdom)

14:00 - 15:30

S3: Broadband Femtocell Technologies III

Chair: Guillaume de la Roche (Mindspeed Technologies, France)

Keynote Speech#2: Alcatel-Lucent Bell Labs

Holger Claussen (Bell Labs, Alcatel-Lucent, United Kingdom)

Use of Learning, Game Theory and Optimization as Biomimetic Approaches for Self-Organization in Macro-Femtocell Coexistence

Ali Imran (Qatar University Wireless Innovation Center (QUWIC), Qatar); Mehdi Bennis (Centre of Wireless Communications, University of Oulu, Finland); Lorenza Giupponi (Centre Tecnològic de Telecomunicacions de Catalunya (CTTC), Spain)

Virtual-Soft-Handoff-Enabled Dominant Interference Cancellation for Enhanced Uplink Performance in Heterogeneous Cellular Networks

Krishna Balachandran (Bell Labs, Alcatel-Lucent, USA); Joseph H. Kang (Bell Labs, Alcatel-Lucent, USA); Mehmet Kemal Karakayali (Bell Labs, Alcatel-Lucent, USA); Kiran M Rege (Bell Laboratories, Alcatel-Lucent, USA)

Primary Component Carrier Selection for a Heterogeneous Network: a Comparison of Selfish, Altruistic and Symmetric Strategies

Parth Amin (Aalto University, Finland); Olav Tirkkonen (Aalto University, Finland); Tero Henttonen (Renesas Mobile Europe, Finland); Esa Pernila (Renesas Mobile Europe, Finland)

16:00 - 17:30

S4: Broadband Femtocell Technologies IV: Closing Session

Chair: Frank A. Zdarsky (NEC Europe Ltd., Germany)

Femtocell Networks: Breaking the Complexity of Centralized Processing with Novel Dual-Stage Receivers

Rizwan Ghaffar (University of Waterloo, Canada); Pin-Han Ho (University of Waterloo, Canada); Umer Salim (Intel Mobile Communications, France); Bin Wu (University of Electronic Science and Technology of China, P.R. China)

CoMP in Heterogeneous Networks: Linear Transceiver Design Using the Minimum Weighted Geometric-MSE Criterion

Tarik Akbudak (University of Duisburg-Essen, Germany); Andreas Czystlik (Universität Duisburg-Essen, Germany)

Bit-Wise Combining for Decode-and-Forward Relays

Namshik Kim (Georgia Institute of Technology, USA); John Barry (Georgia Institute of Technology, USA)

Wireless Over Cable In Femtocell Systems: A Case Study From Indoor Channel Measurements

Jonathan Gambini (Politecnico di Milano, Italy); Stefano Savazzi (Politecnico di Milano, Italy); Paolo Castiglione (FTW, Austria); Umberto Spagnolini (Politecnico di Milano, Italy); Gerald Matz (Vienna University of Technology, Austria)

3.2.6.1.4 IEEE ICC 2012, 1st International Workshop on Small Cell Wireless Networks (SmallNets), 11th June 2012 (Ottawa, Canada)

Motivation: The ever-increasing need for higher data rates and multimedia services leads to stringent requirements on the bit rate/km² that next-generation cellular wireless networks are expected to deliver. This increasing trend has urged mobile operators to examine new ways for improving their coverage, boosting their network's capacity, and lowering their capital and operating expenditures (CAPEX and OPEX). A promising approach to solving this problem is through the deployment of Small Cell Networks (SCNs), which represent a novel networking paradigm based on the idea of deploying short-range, low-power, and low-cost base stations operating in conjunction with the main macro-cellular network infrastructure. The use of SCNs is envisioned to enable next-generation networks to provide high data rates, allow offloading traffic from the macro cell and provide dedicated capacity to homes, enterprises, or urban hotspots. SCNs are also envisioned to pave the way for a plethora of new wireless services. SCNs encompass a broad variety of cell types, such as micro, pico, femto cells, as well as advanced wireless relays, and distributed antennas.

Scope and Objectives:

This workshop is expected bring together academic and industrial researchers in an effort to identify and discuss the major technical challenges and recent results related to small cell networks. Topics of interest include but are not limited to the following:

- Interference analysis, avoidance, and mitigation.
- Power control and power saving mechanisms.
- Synchronization issues for small cell networks.
- Cognitive radio techniques for small cell networks.
- Game theoretical techniques for small cell deployment.
- Co-existence between femtocells and macro-cells.
- Trade-offs between femtocells, picocells, advanced relays, and distributed antenna systems.
- Flexible relaying in interference-limited SCNs.
- Mobility management and handoffs.
- Backhaul and networking issues.
- Open access and closed access operation modes
- Self-configuration, -optimization, and -healing mechanisms for SCNs.
- Economics of femtocells.

Call for Papers Organization (important dates):

Submission due: January 7th, 2012

Decision notification due: February 10th, 2012

Camera-ready submissions due: March 5th, 2012

Workshop Date: June 15th, 2012



Figure 3-8: BeFEMTO Workshop @ ICC 2012 publicized in the website

Workshop Chairs:

- Professor Giuseppe Caire, Electrical Engineering Department, University of Southern California, USA
- Professor Merouane Debbah, Alcatel-Lucent Chair on Flexible Radio at SUPELEC, France)
- Dr. Reinaldo Valenzuela, Bell Labs, Alcatel-Lucent, USA
- Professor Walid Saad, Electrical and Computer Engineering Department, University of Miami, USA
- Dr. Mehdi Bennis, Centre for Wireless Communications, University of Oulu, Finland

The Technical Programme Committee:

- Tansu Alpcan, Technical Univ. of Berlin
- Gunther Auer, DOCOMO Labs
- Elena Veronica Belmega, ETIS/ENSEA
- Leonardo S. Cardoso, SUPELEC
- Vikram Chandrasekhar, Texas Instruments
- Klaus Doppler, Nokia Research Center
- Lorenza Giupponi, CTTC
- Ismail Guvenc, DOCOMO USA Labs
- Zhu Han, University of Houston, USA
- Marios Kountouris, SUPELEC
- Matti Latva-aho, University of Oulu
- Inkyu Lee, Korea University
- Dusit Niyato, Nanyang Technological University
- David Lopez Perez, King's College
- Babis Papadopoulos, DOCOMO USA Labs
- Tony Q.S. Quek, Institute for Infocomm Research
- Osvaldo Simeone, New Jersey Inst. of Tech
- Antonia Tulino, Alcatel-Lucent, Bell-Labs

Workshop program:

8:20 AM - 8:30 AM: Welcome/Opening address

8:30 AM - 9:15 AM: Keynote talk by Prof. Tamer Başar (University of Illinois at Urbana-Champaign, USA).

9:15 AM - 10:15 AM: (Session #1) Handover and Resource Allocation

Joint Interference Management and Handover optimization in LTE Small Cells Network, Veronique Capdevielle (Alcatel CIT, Research & Innovation, FR), Afef Feki (Bell Labs - Alcatel Lucent - France, FR), Elom Sorsy (Telecom Bretagne, FR)

Theoretical Analysis of Handover Failure and Ping-Pong Rates for Heterogeneous Networks, David Lopez-Perez (King's College London, UK), Ismail Guvenc (DOCOMO Innovations, Inc., US), Xiaoli Chu (King's College London, UK)

Downlink SINR distribution in a Heterogeneous Cellular Wireless Network with Biased Cell Association, Sayande Mukherjee (DOCOMO Communications Laboratories USA, Inc., US)

10:15 AM - 10:30 AM: Coffee Break #1

10:30 AM - 12:30 PM: (Session #2) Interference Management

Chair: TBC

Scheduling Strategies for HetNets using eICIC, Andreas Weber (Alcatel-Lucent, DE), Oliver Stanze (Alcatel-Lucent Bell Labs, DE)

Sensitivity Study of Optimal eICIC Configurations in Different Heterogeneous Network Scenarios, Yuanye Wang (Powerwave Technologies, US), Beatriz Soret (Aalborg University, DK), Klaus Pedersen (Nokia Siemens Networks, DK)

CRS Interference Cancellation in Heterogeneous Networks for LTE-Advanced Downlink, Beatriz Soret (Aalborg University, DK), Yuanye Wang (Powerwave Technologies, US), Klaus Pedersen (Nokia Siemens Networks, DK)

Cross-tier Interference Mitigation in Femto-Macro Cellular Architecture, Rizwan Ghaffar (University of Waterloo, CA), Pin-Han Ho (University of Waterloo, CA)

Distributed Algorithm for Downlink Resource Allocation in Multicarrier Small Cell Networks, Furqan Ahmed (Aalto University, FI), Alexis Dowhuszko (Aalto University, School of Science and Technology, FI), Olav Tirkkonen (Aalto University, FI)

Dual-Band Femtocell Traffic Balancing Over Licensed and Unlicensed Bands, Feilu Liu (Polytechnic Institute of NYU, US), Elza Erkip (Polytechnic Institute of NYU, US), Mihaela Beluri (Interdigital, US), Rui Yang (Interdigital, US), Erdem Bala (InterDigital, US)

12:30 PM - 2:00 PM: Lunch Break

2:00 PM - 2:45 PM: Keynote talk by Prof. Jeffrey G. Andrews, The University of Texas, Austin

2:45 PM - 3:45 PM: (Session #3) Evaluation and Modeling

Empirical gains achievable with low altitude remote radio heads in wireless urban links, Luciano Ahumada (Universidad Diego Portales, CL), Rodolfo Feick (Universidad Tecnica Federico Santa Maria, CL), Reinaldo Valenzuela (Lucent Technologies, US), Manuel Gallardo (Universidad Tecnica Federico Santa Maria, CL), Milan Derpich (Universidad Tecnica Federico Santa Maria, CL), Hector Carrasco (Universidad Tecnica Federico Santa Maria, CL)

Assessment of 3D network coverage performance from dense small-cell LTE deployments, Mathieu Brau (SIRADEL, FR), Yoann Corre (SIRADEL, FR), Yves Lostanlen (SIRADEL, CA)

Transmission Strategies for Full Duplex Multiuser MIMO Systems, Thuy-Dan Nguyen (University of Oulu, FI), Le-Nam Tran (University of Oulu, FI), Pekka Pirinen (University of Oulu, FI), Matti Latva-aho (University of Oulu, FI)

3:45 PM - 4:00 PM: Coffee Break #2

4:00 PM - 5:00 PM: (Session #4) Transmission Strategies

On the Coexistence of Macrocell Spatial Multiplexing and Cognitive Femtocells, Ansuman Adhikary (USC, US), Giuseppe Caire (University of Southern California, US)

Distributed Scheduling and Power Control for Cognitive Spatial-Reuse TDMA Networks, Phond Phunchongharn (University of Manitoba and TRILabs, CA), Ekram Hossain (University of Manitoba, CA), Sergio Camorlinga (TRILabs, Winnipeg, Canada, and University of Manitoba, CA)

Location-Based Transmit Power Control for Femtocell Access Points, Poramate Tarasak (Institute for Infocomm Research, SG), Siew Eng Nai (Institute for Infocomm Research, SG), Tony Q. S. Quek (Institute for Infocomm Research, SG), Francois Chin (Institute for InfoComm Research, SG)

5:00 PM – 6:00 PM: Panel Discussion: The way towards the future: Dense or Massive?

Panelists: Dr. Tom Marzetta (Bell Labs, USA), Prof. Sundeep Rangan (NYU Poly, USA), Dr. Thierry Lestable (Technology and Innovation Manager, Sagemcom, France)

3.2.6.1.5 Second Workshop on Cooperative Heterogeneous Networks (coHetNet) in conjunction with ICCCN 2012 , July 30-August 2, 2012 (Munich, Germany)

Motivation: The proliferation of new applications, e.g., mobile TV, Internet gaming, large file transfer, and the development of user terminals, e.g., smart phones, notebooks, has dramatically increased user traffic and network load. Moreover, with the number of wireless subscribers expected to triple over the next five years, it is obvious that current networks will not be able to satisfy customer demands in the

near future. In order to meet this traffic growth and provide service to their customers, vendors and operators are working on the development of new technologies and cellular standards. Within them, heterogeneity in network deployment has been heralded as the most promising way of increasing both the coverage and the capacity of future wireless systems. Thus, it is expected that new elements such as remote radio heads, picocells, femtocells, and relay nodes will be deployed overlying macrocells. Therefore, future networks are expected to be heterogeneous. In this way, networks will be closer to users, and system capacity will be enhanced through a better spatial spectrum reuse.

However, although HetNets are envisioned to support the increasing data traffic demand and meet the requirements imposed for the fourth generation of mobile networks, they also lead to new technical challenges never faced before. For example, due to the larger number of cells and thus of cell boundaries, the management of interference becomes an intricate problem. Since centralized network planning and optimization cannot deal with the individualistic nature of user-deployed cells, e.g., femtocells, a key to the success of HetNets is the cooperation between nodes in a decentralized and distributed manner. Such cooperation is the only way to ensure a proper network operation. However, cooperation is not easy to achieve due to different issues and threats imposed by the network itself, e.g., limited back-haul capabilities, dynamics of traffic and radio channel, energy consumption, operational costs, etc.

The target of this workshop is to bring together academic and industrial researchers to identify and discuss all recent challenges and developments related to cooperation in HetNets, and establish future research directions. Topics of interest include but are not limited to the following:

- Collaborative techniques in macro/pico/femto-cellular networks
- Performance modeling and simulation for HetNets
- Cooperative communications between HetNet nodes.
- Downlink and uplink PHY/MAC design for cooperative HetNets.
- Self-configuration, self-optimization and self-healing in HetNets.
- Cognitive radio techniques in HetNets.
- Mobility management in HetNets.
- Load balancing in HetNets.
- Restricted access versus open-access for low-power HetNet nodes.
- Interference analysis, mitigation and avoidance in HetNets.
- Power saving mechanism in HetNets.
- Distributed radio resource management in cooperative HetNets.
- Cooperative sensing techniques and feedback in HetNets.
- Remote radio heads planning and deployment.
- Expanded region picocells planning and deployment.
- Cooperative relaying in HetNets.
- eICIC techniques in LTE-Advanced HetNets.
- MIMO techniques in HetNets.
- Positioning and tracking systems based on HetNets.

In addition, Dr. Stefan Brueck from Qualcomm will give a keynote speech at the workshop.

3.2.6.1.6 IEEE PIMRC 2011, Panel Session on “Femtocells & WiFi: Towards Cost efficient Ubiquitous Broadband”, 12th September 2011 (Toronto, Canada)

Befemto project organized a special panel session in the PIMRC 2011 (Toronto, Canada) on the Femtocells vs Wi-Fi topics. In this panel BeFemto participated with representatives from Sagemcom, Telefonica, Oulu University and also representatives from InterDigital and Mitsubishi (representing FP7 Artist4G) were invited.

It was discussed: traffic offloading using femtos and Wi-Fi, standards overview and scenarios of use (femtos and Wi-Fi). There was a live discussion with a Microsoft representative that defended Wi-Fi as the only future option due to low cost services offered (e.g. VoIP) and generalized availability. Befemto representatives presented their position that both are complementary, femtonodes providing a controlled quality of service and continuity to the ubiquitous outdoor coverage, in the case of low outdoor macrocell signal penetration, being these two features not achievable by Wi-Fi.

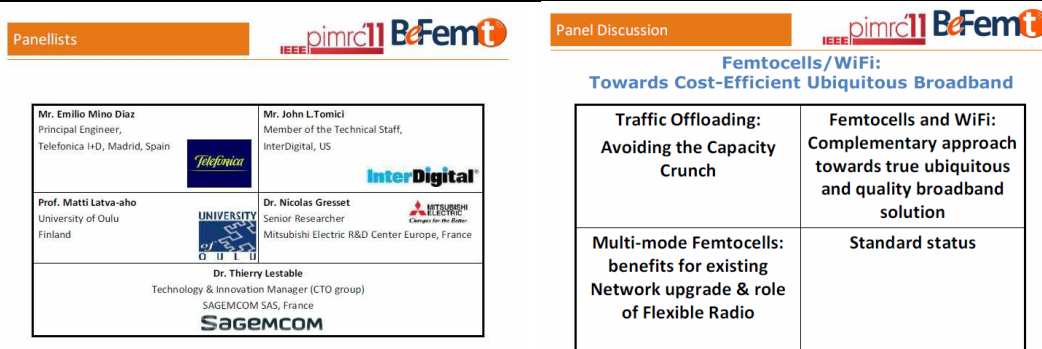

Figure 3-9: BeFEMTO Panel Session @ PIMRC 2011, Toronto, Canada

3.2.6.2 Training Schools

BeFEMTO academic partners have organised two (2) training schools: one summer school hosted by the University of Oulu (Finland), and a winter school organized by the CTTC, Barcelona (Spain).

The summer school was dated just before the International Symposium on Information Theory (ISIT) in St-Petersburg, which took place from July 31 until August 5. This summer school was organized jointly used for both European FP7 projects Earth and BeFEMTO as part of their dissemination activities, including femtocell and energy efficiency issues as one of the key topics of the program.

An additional training school, specific on the topic of femtocells, was organized in Barcelona in collaboration with FREEDOM project, also devoted to research on next-generation femtocell technologies, during the whole week 6 – 10th February 2012.

Further details are given hereafter.

3.2.6.2.1 International Wireless Information Theory Summer School 2011 (27th -29th July 2011, Oulu, Finland)

This summer school [53] took place from 27th to 29th of July, 2011 in Oulu, Finland.



Figure 3-10: BeFEMTO Summer School 2011, publicized in the BeFEMTO website

Motivation: Leading experts in Wireless Information Theory introduced participants to new areas not yet covered in a comprehensive manner in the literature. In addition, the summer school provided a stimulating atmosphere to discuss and exchange ideas. Target groups were graduate students and postdoctoral researchers.

Scope and Objectives:

The purpose of this advanced course was to provide a forum to people interested in the recent developments of the information theory.

Any contribution in the general area of wireless communication or related information theory with a special emphasis on small cells, energy efficiency, flexible relaying and interference channels were welcome.

School Organization:

The Wireless Information Theory Summer School was hosted by the Centre for Wireless Communications, University of Oulu.

The event was planned to be well combined with ISIT 2011 [54] which was held on July 31 - August 5, 2011, in Saint Petersburg, Russia.

Registration fee covered lectures and meals according to the programme during all three days of the Summer School. For students of GETA and INFOTECH programmes special conditions applied.



Figure 3-11: BeFEMTO Summer School Sponsors and co-sponsor

The Summer School was organized by:

- University of Oulu, Centre for Wireless Communications
- BeFEMTO project
- EARTH project [55]

The Steering Committee consists of:

- Markku Juntti, University of Oulu (CHAIR)
- Behnaam Azhang, Rice University
- Ruyiji Kohno, Yokohama National University
- Anthony Ephremides, University of Maryland
- Lars Rasmussen, Royal Institute of Technology Stockholm
- Mikael Skoglund, Royal Institute of Technology Stockholm
- Matti Latva-aho, University of Oulu
- Mehdi Bennis, University of Oulu

The technical program committee solicited contributions for an early-evening poster session devoted to recent results. It was especially encouraged graduate students and postdocs to present recent results as well as open problems related to their research.

Poster proposal submission: June 15th, 2011

Notification of acceptance: June 23rd, 2011

Speakers:

The summer school was led by the following speakers:

- Prof. Sennur Ulukus, University of Maryland, College Park, MD, USA
- Prof. Aylin Yener, Pennsylvania State University, University Park, PA, USA
- Prof. Gerhard Kramer, Technical University of Munich, Munich, Germany
- Prof. Bobak Nazer, Boston University, Boston, MA, USA
- Prof. Jyri Hämäläinen, Aalto University, Finland
- Dr. Gunther Auer, NTT DOCOMO Euro-Labs, Munich, Germany
- Prof. Tadashi Matsumoto, Centre for Wireless Communications, Oulu, Finland

Program:

The Wireless Information Theory Summer School consisted of two lecture days and a one-day workshop including a poster session.

1. During the first day the topic to be treated was the "Energy efficiency of future networks". In this lecture, it was covered classical as well as modern topics in energy-efficiency in wireless communications. It was first considered classical battery-powered wireless devices and present classical results in energy-efficient communications of these devices in cellular, ad-hoc and sensor network environments. In particular, it was been presented classical results on power control for cellular systems, MIMO beam-forming as a means of energy-efficient directional communications,

energy-efficient scheduling, and energy-efficient routing in ad-hoc and sensor networks. It was been considered modern wireless devices which are powered by energy-harvesting rechargeable batteries. It was been presented recent results on information-theoretic as well as network-theoretic treatment of such networks. In particular, it was been considered information-theoretically achievable rates for energy-harvesting communication channels, as well as scheduling of data transmission to minimize delay and maximize throughput in energy-harvesting communication systems.

Two presentations were handled by Prof. Sennur Ulukus, University of Maryland, College Park, MD, USA and by Prof. Aylin Yener, Pennsylvania State University, University Park, PA, USA.

2. In the second day, the area covered was the "Interference, coordination and cooperation in heterogeneous networks and local connectivity".

Interference is one of the core aspects of the wireless medium. That is, each receiver observes a noisy superposition of all concurrently transmitted signals, from which it must extract its desired message(s). The classical approach is to avoid interference either through time-division, frequency-division, or some other form of orthogonalization. However, interference is not simply additional noise: it is highly structured due to the fact that each transmitted signal is drawn from a codebook. This tutorial provided an overview of achievable strategies, outer bounds, and known capacity results for interference channels, starting from the canonical model of two transmitter-receiver pairs that share a common channel. If there are three or more transmitter-receiver pairs, this opens up the possibility of interference alignment. Here, the key result is that, through alignment, each transmitter-receiver pair can achieve up to half the rate that would be available to it in an interference-free setting, regardless of the number of users in the system.

This topic was explained by Prof. Gerhard Kramer, Technical University of Munich, Munich, Germany, which covered the following aspects:

- Models: multi-access channels (MACs), interference channels
- Preliminaries 1: random coding for MACs, superposition coding
- Preliminaries 2: cut-set bound, Fourier-Motzkin elimination
- AWGN channels: standard form, cut-set bound, basic strategies, strong interference
- The Han-Kobayashi region
- Deterministic channels

On the other hand, Prof. Bobak Nazer, Boston University, Boston, MA, USA, gave an additional approach to this area of knowledge covering aspects as:

- Inseparability of parallel interference channels
- Cadambe-Jafar interference alignment scheme
- Ergodic interference alignment
- Fixed channels: degrees-of-freedom, lattice strategies
- General message sets: X channels and beyond

3. The last day of the summer school included two workshops from European projects BeFEMTO and EARTH, and a final keynote speaker from the University of Oulu.

The Workshop exposed by BeFemto had the title: "Femtocells: Technologies and Deployment", and was explained by Prof. Jyri Hämäläinen, Aalto University, Finland. The issues to be covered in this workshop were extracted from the following aspects: the third generation partnership project (3GPP) has adopted the femtocell concept as one component technology for 3G, LTE and LTE-Advanced to improve the indoor coverage of cellular services, as well as to boost the spectral utilization efficiency. The Femto Base Station (FBS) is an inexpensive compact base station providing equal radio access interface as common macrocellular base station (MBS) towards UEs. The FBS devices are deployed autonomously by subscribers in residential or enterprise premises in a plug-and-play manner.

The lecture introduced the femtocell concept and discussed on practical and theoretical aspects related to femtocells.

On the other hand, the Workshop by Earth had the topic of: "Energy aware radio and networking technologies", presented by Dr. Gunther Auer, NTT DOCOMO Euro-Labs, Munich, Germany. Finally, the Closing Keynote treated about: "Iterative Processing Allowing Intra-Link Errors for Cooperative Communications" by Prof. Tadashi Matsumoto, Centre for Wireless Communication, Oulu, Finland.

3.2.6.2.2 Joint BeFEMTO & Freedom Winter School 2012 (6th-10th February 2012, Barcelona, Spain)

This winter school [45] was organized thanks to the joint work of ICT IP BeFEMTO [52], ICT STREP Freedom [51] and MC Greenet [56].



Figure 3-12: BeFEMTO Winter School Sponsors

Motivation: Femtocells, despite their name, pose a potentially large disruption to the carefully planned cellular networks that now connect a majority of the planet's citizens to the Internet and with each other. Femtocells - which by the end of 2010 already outnumbered traditional base stations and by March 2012 being deployed at a rate of about five million a year – both enhance and interfere with this network in ways that are not yet well understood. Will femtocells be crucial for offloading data and video from the creaking traditional network? Or will femtocells prove more trouble than they are worth, undermining decades of careful base station deployment with unpredictable interference while delivering only limited gains? Or possibly neither: are femtocells just a “flash in the pan”; an exciting but short lived stage of network evolution that will be rendered obsolete by improved WiFi offloading, new backhaul regulations and/or pricing, or other unforeseen technological developments?

Scope and Objectives:

This unique and unprecedented one-week winter school on femtocells overviewed femtocells, demystified their key aspects, and provided a preview of the next few years, by discussing in great depths the many aspects and facets of the femtocell eco system. The speakers of this one week course were an exclusive set of leading industrials and academics, who have been shaping, driving and designing femtocells and their networked embodiment for the past years.



Figure 3-13: BeFEMTO Winter School banner @ CTTC, Barcelona, Spain

School Organization:

The workshop took place at the Castelldefels premises of CTTC, Barcelona, Spain. The Femto Winter School 2012 was jointly organized by ICT IP BeFemto, ICT STREP Freedom and MC Greenet.



Figure 3-14: BeFEMTO Winter School 2012, publicized in the BeFEMTO website

Organizing Committee:

- Mischa Dohler (CTTC, Spain)
- Josep Vidal (UPC, Spain)
- Christos Verikoukis (CTTC, Spain)

Speakers:

The winter school was addressed by the following speakers:

- Thierry Lestable (Sagemcom, France)
- Josep Vidal (UPC, Spain)
- Prabhakar Chitrapu (InterDigital, USA)
- Andreas Maeder (NEC, Germany)
- Marius Pesavento (TU Darmstadt, Germany)
- Mariano López (TTI, Spain)
- Guillaume Villemaud (INSA Lyon, France)
- Harpreet Dhillon (Univ. of Texas at Austin, USA)
- Zubin Bharucha (DoCoMo, Germany)
- Massinissa Lalam (Sagemcom, France)
- Sergio Barbarossa (Univ. Rome, Italy)
- Mehrdad Shariat (Univ of Surrey, UK)
- Mischa Dohler (CTTC, Spain)
- Ali Imran (QUWIC Doha, Qatar)
- Ana Galindo-Serrano (CTTC, Spain)
- Christos Verikoukis (CTTC, Spain)
- Josep Mangues (CTTC, Spain)
- Jaime Ferragut (CTTC, Spain)
- Jose Nunez (CTTC, Spain)

Program:**DAILY SCHEDULES**

08h30 - 09h00 Registration
 09h00 - 10h30 Invited Talk
 10h30 - 11h00 Coffee Break
 11h00 - 12h30 Invited Talk
 12h30 - 14h30 Lunch
 14h30 - 16h00 Invited Talk
 16h00 - 16h30 Coffee Break & Student Posters
 16h30 - 18h00 Invited Talk

MONDAY – INTRODUCTION DAY

[09.00-10.30, 1.5h]

An Industrial Introduction to Femtocells

Thierry Lestable, Sagemcom, France



Figure 3-15: BeFEMTO Winter School 2012

[11.00-12.30, 1.5h]

Recent Trends in Femtocell Research

Josep Vidal, UPC, Spain

[14.30-16.00, 1.5h]

Driving & Drivers of the Femto Forum

Prabhakar Chitrapu, InterDigital, Femto Forum WG3 Vice Chair, USA

[16.30-18.00, 1.5h]
3GPP LTE Evolved Packet System & Application to Femtos
Andreas Maeder, NEC, Germany

TUESDAY – HARDWARE, PHY & COVERAGE DAY

[09.00-10.30, 1.5h]
LTE-A PHY Layer Overview & Femto Design Challenges
Willem Mulder & Marius Pesavento, mimoOn, Germany

[11.00-12.30, 1.5h]
Femto LTE-A Hardware Design Challenges
Mariano López, TTI, Spain

[14.30-16.00, 1.5h]
Coverage Prediction for Heterogeneous Networks: From Macrocells to Femtocells
Guillaume Villemaud, INSA Lyon, France

[16.30-18.00, 1.5h]
Analysis of K-tier Heterogeneous Cellular Networks
Harpreet Dhillon & Jeffrey Andrews, University of Texas at Austin, USA

WEDNESDAY – INTERFERENCE & RRM DAY

[09.00-10.30, 1.5h]
LTE/LTE-A Interference Coordination for Femtocells
Zubin Bharucha, Docomo Labs Europe, Germany

[11.00-12.30, 1.5h]
Interference Management in Co-Channel Femtocell Deployment
Massinissa Lalam, Sagemcom, France

[14.30-16.00, 1.5h]
Distributed Interference Management in Femtocell Networks
Sergio Barbarossa, University of Rome, Italy

[16.30-18.00, 1.5h]
Cross-Layer Scheduling for Emerging Femto Broadband Systems
Mehrdad Shariat, University of Surrey, UK

THURSDAY – SON DAY

[09.00-10.30, 1.5h]
LTE/LTE-A SON for Femtocells
Mischa Dohler, CTTC, Spain

[11.00-12.30, 1.5h]
Cognitive & Dognitive Femtocell Networks
Ana Galindo-Serrano, CTTC, Spain

[14.30-16.00, 1.5h]
A Unified View on Self-Organization Techniques for Heterogeneous Networks [Part I]
Ali Imran, QUWIC, Qatar

[16.30-18.00, 1.5h]
A Unified View on Self-Organization Techniques for Heterogeneous Networks [Part II]
Ali Imran, QUWIC, Qatar

FRIDAY – NETWORKING & EXPERIMENTATION DAY

[09.00-10.00, 1h]
Energy-Efficient Mobility Management for the Integrated Macrocell-Femtocell LTE Network
Christos Verikoukis, CTTC, Spain

[10.00-10.30, 30min]

Overview of the BeFEMTO Networking Architecture
Josep Mangués, CTTC, Spain

[10.45-11.30, 45min]

Local Location Management in Networks of Femtocells
Jaime Ferragut, CTTC, Spain

[11.30-12.15, 45min]

Distributed Routing in All-Wireless Networks of Femtocells
José Núñez & Josep Mangués, CTTC, Spain

[12.30-13.45, 1h15min]

All-Wireless Network of Femtocells Testbed: Distributed Routing
José Núñez & Josep Mangués, CTTC, Spain

[13.45-14.00, 15min]

Closure of Femto Winter School 2012
Mischa Dohler, CTTC, Spain

Conclusions:

The workshop was attended by **50 physical attendees** and **20 remote live-video attendees**, which could and did ask questions per **Twitter** and stayed for virtually the entire week.

All the presentations are published in the internet as PDF files (BeFEMTO webpage [52] and BeFEMTO winter school website [55]), as well as YouTube Videos (BeFEMTO channel [57] and Mischa Dohler technology channel [58]).

Furthermore, the Winter School had presentations well balanced from industry and academia. The sessions included a poster presentation and there were generally very lively discussions.

3.2.7 BeFEMTO website

The BeFEMTO website [52] represents one of the main media for project's activities dissemination, over specialized public, non-technical or general readers. As a consequence, the design and setup of the BeFEMTO website was one of the first tasks developed after the project kick-off. The skeleton of the website has been implemented by "Eurescom", which is also in charge of the hosting, domain registration and technical maintenance for the public website. Partners have contributed providing specific contents for the web and uploading this information through the T7.2 leader. Periodically, the website content has been updated including the availability of new deliverables to download, YouTube Videos, the organization of events like workshops, panel sessions, summer and winter school, general assemblies, etc.

3.2.7.1 Goal and Contents

The public website is intended to provide a vision of the BeFEMTO project to the general public over the world. It is a part of the WP7 work package on project dissemination and is one of the main media for dissemination of the BeFEMTO public results. More specifically, the website includes information regarding the project's objectives, public deliverable reports and papers from conferences and workshops presented by project's partners.

3.2.7.2 Domain and Logo

The URL of the website is <http://www.ict-befemto.eu/>. Eurescom hosts the website and ensures the integrity of the project data by periodic backups, which are maintained on a different storage server.

In addition, the website makes use of the project's logo with an attractive visual identity, which helps rising up the recognition of the project by public throughout the dissemination activities. The website includes a clearly acknowledge to the EU as a source of funding and uses the EU logo: the blue EU flag with 12 yellow stars and the FP7 logo.

On the other hand, the BeFEMTO website has been submitted to search engines to ensure widespread dissemination of the project website.

3.2.7.3 Sitemap

The website has several sections devoted to present the project to external visitors. A screenshot of the home page is shown in next figure.

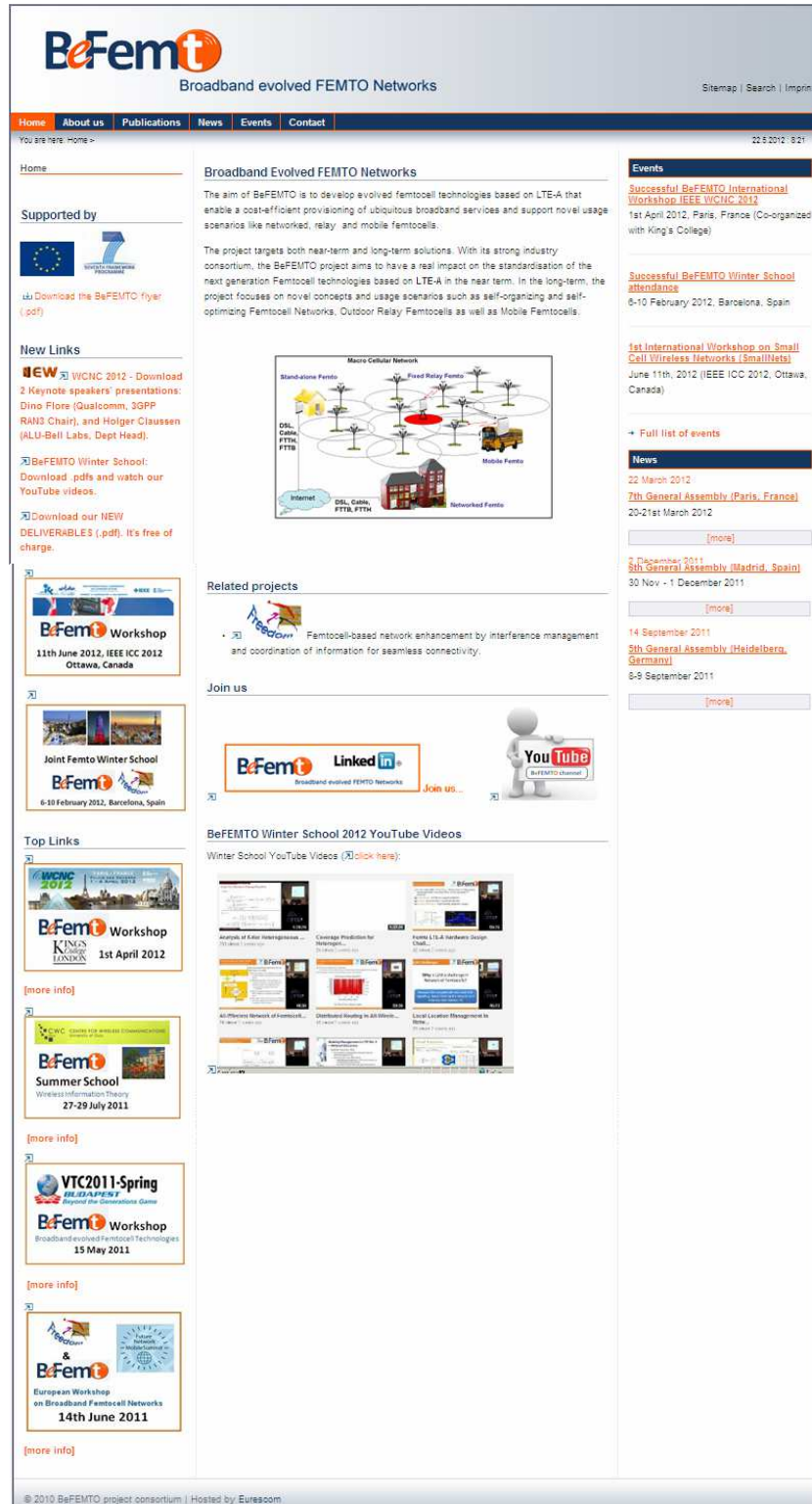

Figure 3-16: Screenshot of the BeFEMTO home page

The next figure depicts the sitemap of the BeFEMTO website.

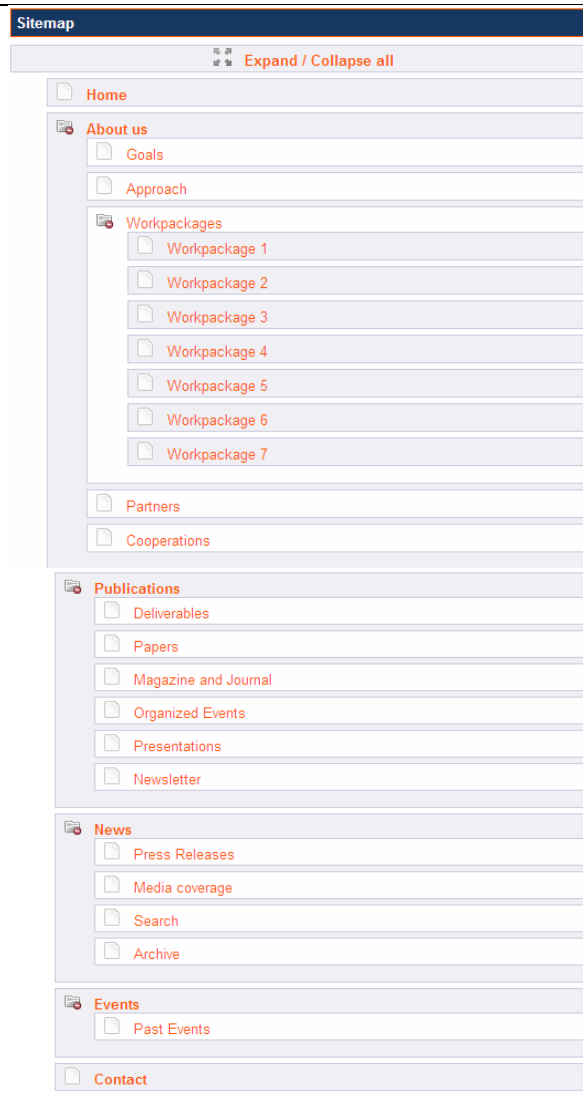

Figure 3-17: Sitemap of BeFEMTO website

The website has the following main sections:

- **Home:** the home page introduces shortly the BeFEMTO project and gives the most relevant information as the latest news and events.
- **About us:** on this page, the main goals and foreseen activities of the project are described. Also the list of work packages is included, together with a small explanation about their objectives through the life of the project, and a list of the project partners, their logos and the links to their respective websites.
- **Publications:** this section lists research papers and articles in magazines and journals related to the project, published by partners, with specific information about title, authors, conference or workshop where they have been presented, etc. There are direct links to the conferences, workshops, magazines and journals, but no direct link to the documents or possibility to download them, due to potential copyright issues. On the other hand, the public deliverables are available to any visitor in the website.
- **News and Events:** these pages show general news and events about the project. Some examples are: the Call for papers for BeFEMTO workshops, general assemblies, etc. The release of public deliverables has been announced in this section. Moreover, some relevant links about scientific domains covered in the project have been listed.
- **Contact:** this section enables people to easily get in touch with relevant contact people of the BeFEMTO project Consortium.

3.2.7.4 External Links

The website covers several external links on topics related to the project and other projects whose goals and activities are linked to BeFEMTO:

- The BeFEMTO website includes a link to the Freedom project, as well as the Freedom project website has a link towards BeFEMTO under "Related Projects" on their own website.
- The website includes a link to advertise the BeFEMTO LinkedIn group [3]. The link is placed in the section "About us", below Funding scheme: IP.
- A direct link to the BeFEMTO channel created in YouTube is available in the main webpage.
- The link to BeFEMTO website is included in the Wikipedia. Due to problems to introduce the term "BeFEMTO" because of commercial advertising motivation to remove BeFEMTO web pages, the link to the BeFEMTO website has been included in strategic and key terms already developed like: femtocell, 4G and LTE-Advanced.
- The site has been submitted to search engines [59].

3.2.7.5 Downloads

The website has included the possibility to download the BeFEMTO flyer. Also, it has been implemented the tool to allow the registration needed to download the deliverables for free.

1. BeFEMTO flyer.

It is allocated below the EU logo, with only a hyperlink with the text "Download BeFEMTO flyer (.pdf).



Figure 3-18: BeFEMTO web page, hyperlink to BeFEMTO flyer

2. Presentations.

A list of the BeFEMTO presentations is available in the "Presentations" section.

3. Deliverables.

All the BeFEMTO public deliverables are accessible to the general public through the "download" option in the website. The visitor has to fill out some information (organization and country of origin) to be authorized for download the documents. This information is employed for statistical purposes. For all people requesting BeFEMTO deliverables a list will be generated, accessible via web interface. The Consortium or the EC could reuse this information for statistical analysis.

Please fill in the requested fields. After submission, you will be redirected to the download page.

Organisation *

Country *

Figure 3-19: Form to request BeFEMTO deliverables

Deliverables

Thank you for your interest in the results of BeFemto. The main deliverables of this project are available to everybody without cost. We would however like to know who our customers and users of our results are. Please fill in your address details below.

After pressing the "Submit" button you will be redirected to the download page with access to the deliverables in pdf format.

The following deliverables with an linked abstract are available (as submitted to the European Commission):

Del. no.	Deliverable name	Workpackage No.	Nature	Dissemination level	Delivery date
D1.1	Website of the project	1	O	PU	M1
D1.2	Evaluation of progress status of the project, issue 1	1	R	CO	M12
D2.1 (Abstract)	Description of baseline reference systems, use cases, requirements, evaluation and impact on business model	2	R	PU	M12
IR3.2 (Abstract)	Radio Access Specs and Promising Techniques for Indoor Standalone Femtocells	3	R	PU	M12
D4.1 (Abstract)	Promising SON enabling & multi-cell RRM techniques for networked femtocells	4	R	PU	M12
D5.1 (Abstract)	Femtocell access control, networking, mobility, and management concepts	5	R	PU	M12
D6.1 (Abstract)	Selection of scenarios for proof of concept testbeds and specifications for key building blocks functionalities and interfaces	6	R	PU	M12
D7.1 (Abstract)	Standardization and Dissemination Activities and Results	7	R	PU	M12
D4.2 (Abstract)	SON enabling techniques (final)	4	R	PU	M21
D1.3	Evaluation of progress status of the project, issue 2	1	R	CO	M24
D2.2 (Abstract)	The BeFEMTO system architecture	2	R	PU	M24
D3.1 (Abstract)	RF front-end solutions	3	R	PU	M24
IR3.3 (Abstract)	Promising Interference and Radio Management Techniques for Indoor Standalone Femtocells	3	R	PU	M24
D4.3 (Abstract)	Multi-cell RRM for networked femtocells (final)	4	R	PU	M24
D5.2 (Abstract)	Femtocell access control, networking, mobility and management mechanisms (final)	5	R	PU	M24
D6.2 (Abstract)	Integration of selected algorithms into platforms & interfaces finalization	6	R	PU	M24
D1.4	Final project report	1	R	PU	M30
D2.3	The BeFEMTO system concept and its performance	2	R	PU	M30
D3.2	Interference and RRM solutions for indoor standalone femtocells	3	R	PU	M30
D4.4	Integrated SON techniques for femtocells radio access	4	R	PU	M30
D5.3	Evaluation report of femtocells networking, mobility and management solutions	5	R	PU	M30
D6.3	Final proof of concepts validation, results and analysis	6	R	PU	M30
D7.2	Final report on the standardisation and dissemination activities of the project	7	R	PU	M30

[1] R = Report, P = Prototype, D = Demonstrator, O = Other

[2] Measured in months from the project start date (Month 1).

Figure 3-20: BeFEMTO deliverables in the website

The deliverables have been downloaded 215 times (up to May of 2012), and the next figures show their classifications taken into account the country of origin and the organization name.

BeFEMTO deliverables downloaded
Percentage by Country

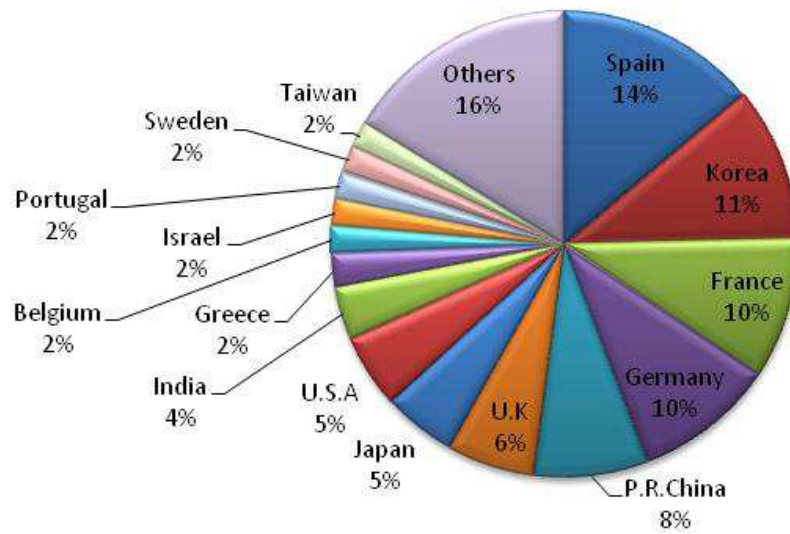

Figure 3-21: BeFEMTO deliverables downloaded: classification by country

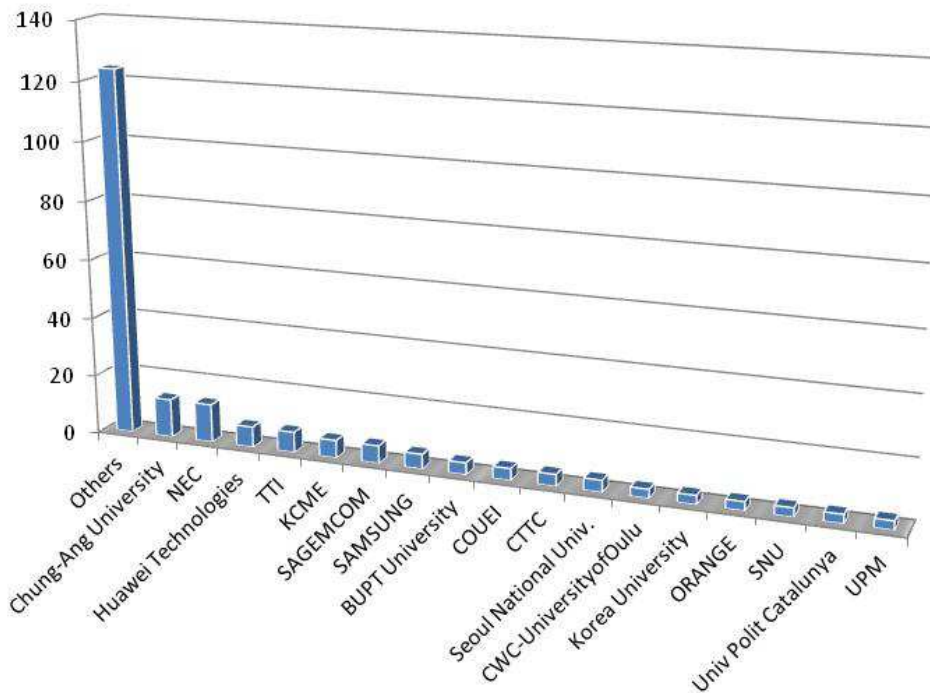

Figure 3-22: BeFEMTO deliverables downloaded: classification by organization

4. Call for Papers (BeFEMTO workshops).

The homepage website and the “news” section include detailed information about the “Call for Papers” of BeFEMTO workshops. The webpage includes direct links to the main conference and to the “submission of papers” for researchers external to the consortium.

3.2.7.6 Statistics

The accesses to the BeFEMTO website have been monitored monthly. During the website monitoring, it could be found some correlation between the project website visibility and physical events to which partners participated actively.

The following figure reports the total number of visits on the public website from January of 2010 to mid of May 2012. As is shown in the graph, the number of unique visitors has been growing continuously.

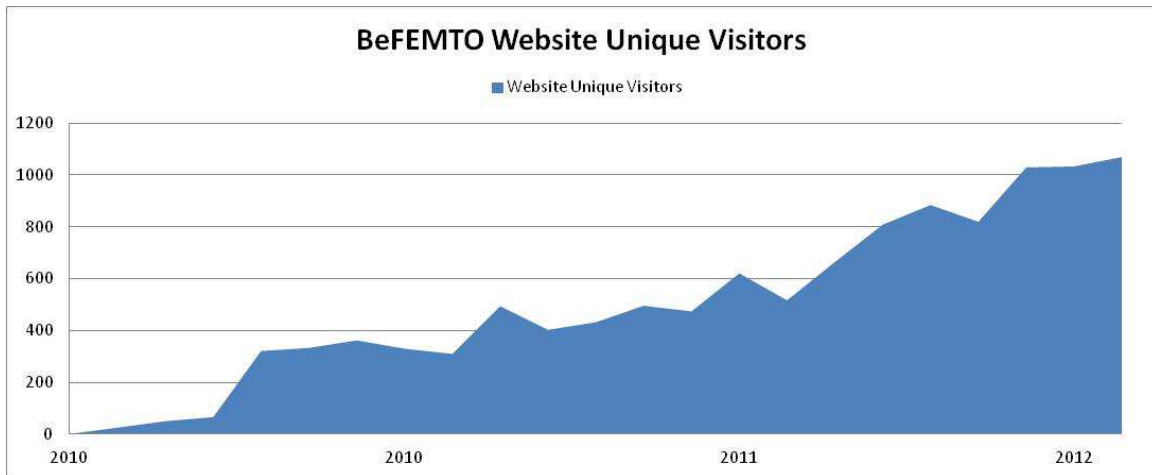

Figure 3-23: Monthly access statistics for BeFEMTO website

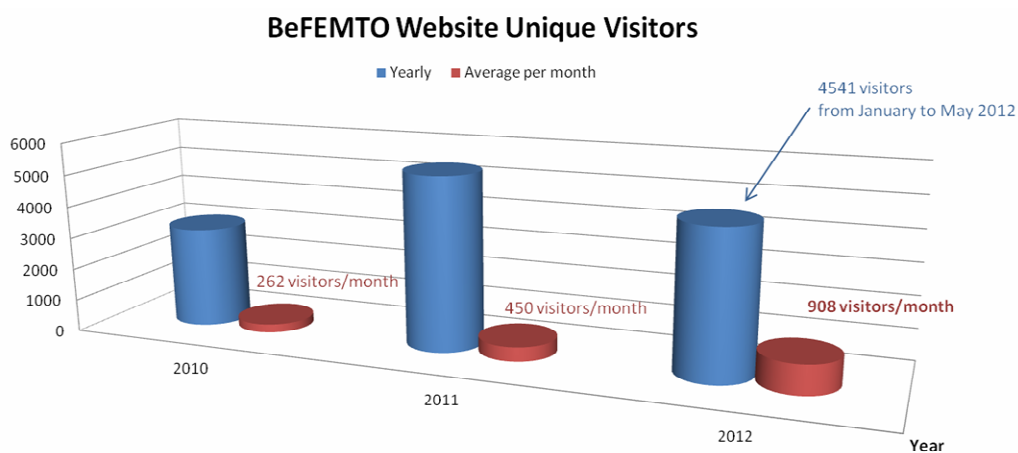

Figure 3-24: Access statistics for BeFEMTO website: yearly and average per month

Statistics show the distribution of originating countries and it's clear that the BeFEMTO website has attracted a significant number of visits originating from countries far beyond the original project consortium. The next figures show the top 25 visits grouped by country of origin for each one of the years involved in the project (2010, 2011 and up to May 2012).

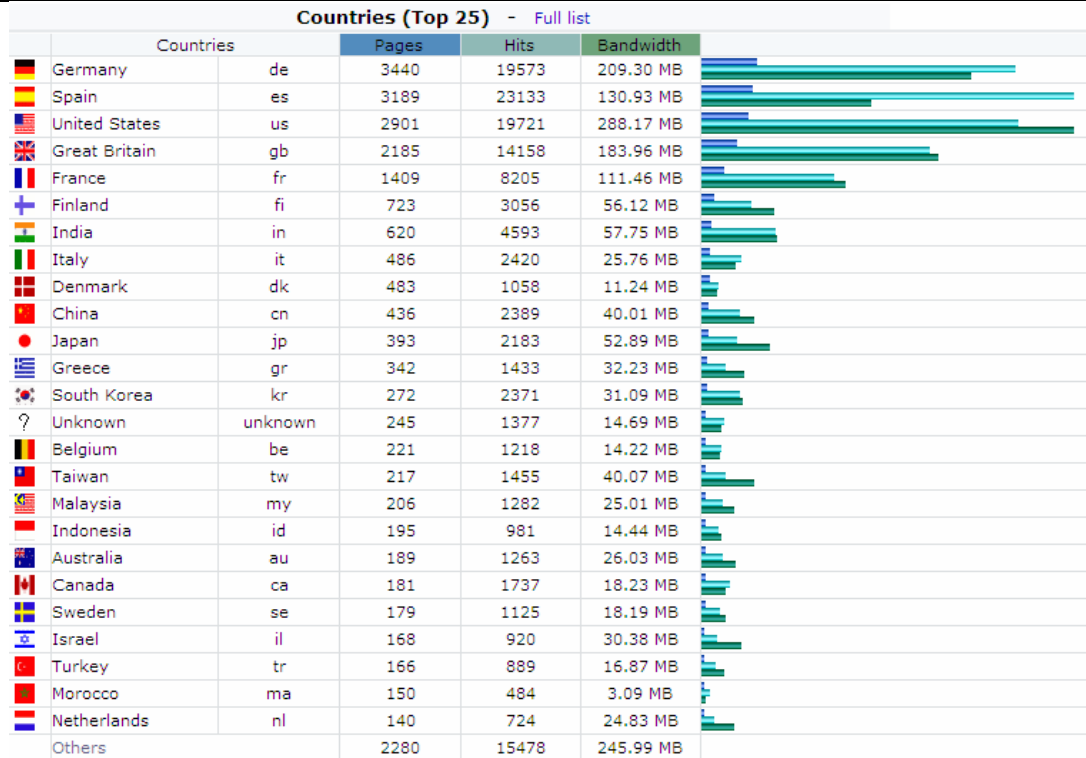

Figure 3-25: Website top visits by country (Year 2010)

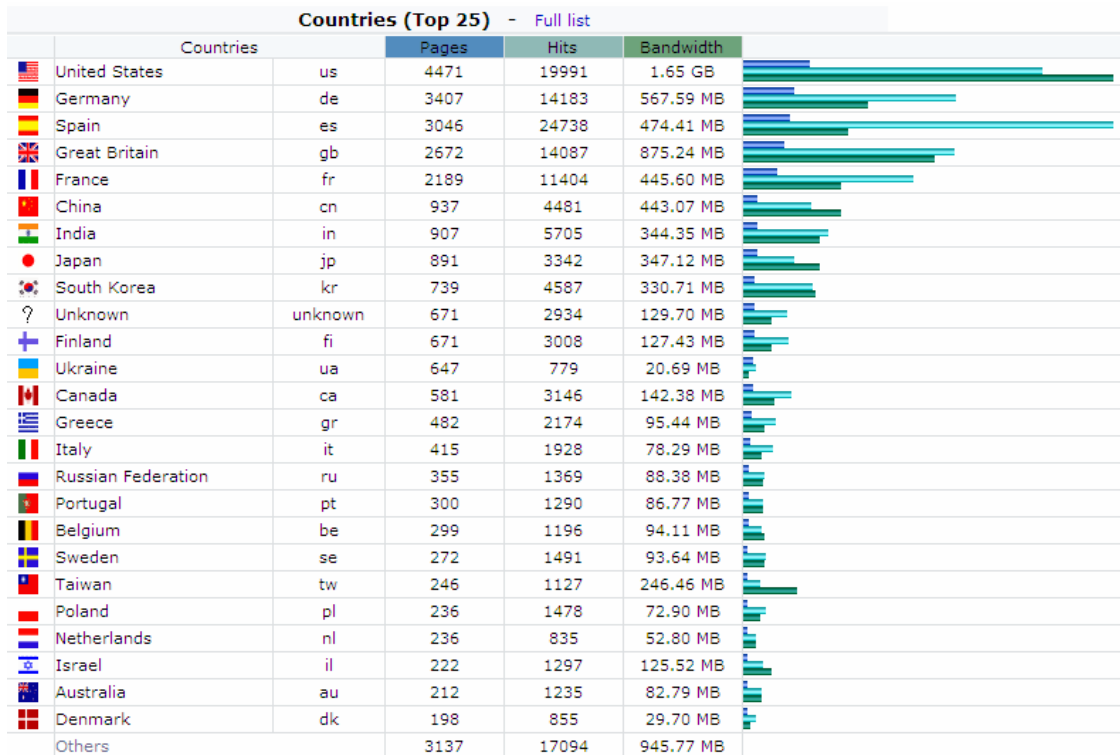

Figure 3-26: Website top visits by country (Year 2011)

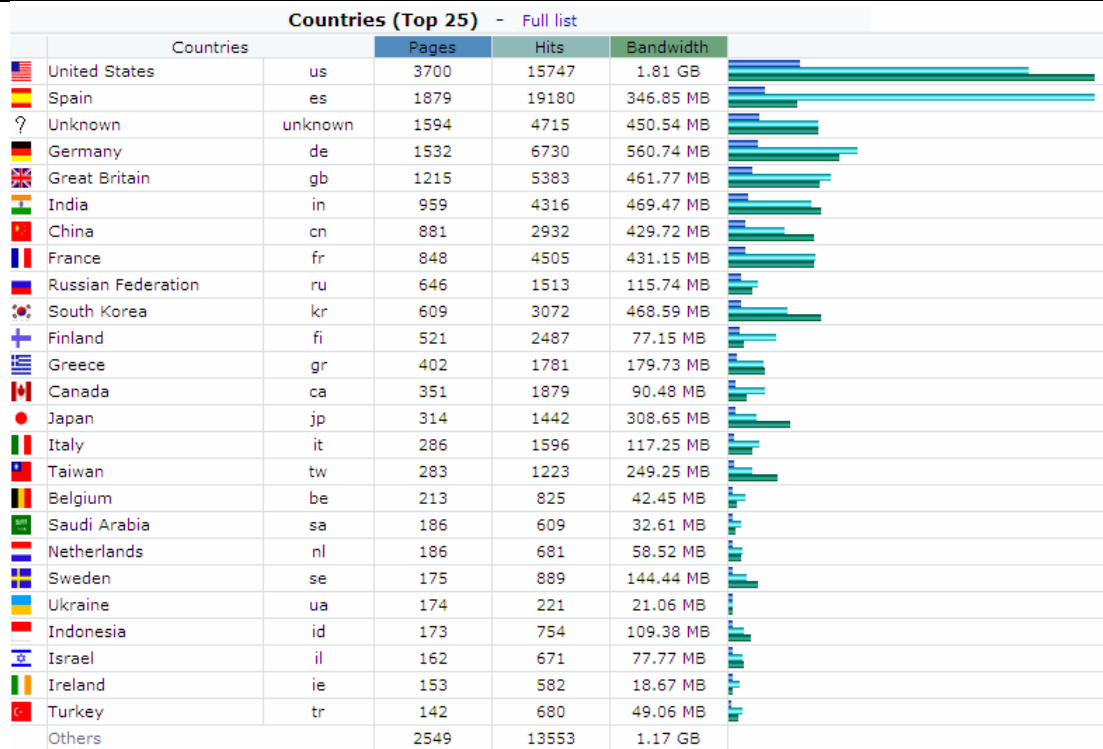

Figure 3-27: Website top visits by country (Year 2012, up to May)

Another very interesting statistic is via which site the visit has been realized. As it's expected, the main source of visits is due to direct links contained in emails, bookmarks, etc. (74.5%, 69.6% and 67.9% for 2010, 2011 and 2012 year respectively).

On the other hand, the following figures show that a great number of visits have had its origin from the wikipedia website (where the BeFEMTO link has been included during the T7.2 dissemination). Meanwhile, other visits have come from search engines like Google, other FP7 projects like the Freedom project, and the linkedin webpage (which has a BeFEMTO group).

In order to have more information about what dissemination channel is more effective in terms of publicizing the BeFEMTO website, we can consult the statistics and observe in the next figures that the terms "femtocell", "LTE-Advanced" and "4G" in the Wikipedia (en) have the highest ranking in the BeFEMTO website dissemination.

Origin	Pages	Percent	Hits	Percent
Direct address / Bookmark / Link in email...	8468	74.5 %	11084	76.5 %
Links from an Internet Search Engine - Full list	831	7.3 %	862	5.9 %
- Google	816		846	
- Unknown search engines	5		5	
- Baidu	3		3	
- Yahoo!	3		3	
- Windows Live	2		2	
- Ask	1		1	
- Yandex	1		1	
- Google (Images)	0		1	
Links from an external page (other web sites except search engines) - Full list	2060	18.1 %	2529	17.4 %
- http://en.wikipedia.org/wiki/LTE_Advanced	608		621	
- http://en.wikipedia.org/wiki/4G	588		588	
- http://en.wikipedia.org/wiki/Femtocell	309		309	
- http://www.ict-freedom.eu	59		59	
- http://translate.googleusercontent.com/translate_c	42		457	
- http://en.wikipedia.org/wiki/4g	37		37	
- http://www.eurescom.eu/activities/EU_Projects/befemto.asp	26		26	
- http://cordis.europa.eu/fp7/ict/future-networks/projects_en.html	26		26	

Figure 3-28: BeFEMTO website visits, origin site (Year 2010)

Origin	Pages	Percent	Hits	Percent
Direct address / Bookmark / Link in email...	12818	69.6 %	15303	72.1 %
Links from an Internet Search Engine - Full list	3192	17.3 %	3270	15.4 %
- Google 3091 3154				
- Yahoo!	68 68			
- Unknown search engines	14 14			
- Yandex	5 5			
- Baidu	3 16			
- MyWebSearch	3 3			
- Windows Live	3 3			
- Ask	2 2			
- Google (Images)	1 3			
- Seznam	1 1			
- Excite	1 1			
Links from an external page (other web sites except search engines) - Full list	2391	12.9 %	2608	12.2 %
- http://en.wikipedia.org/wiki/LTE_Advanced	485 485			
- http://en.wikipedia.org/wiki/4G	329 329			
- http://bi.qintra.com/strategyportal/default.aspx	231 231			
- http://en.wikipedia.org/wiki/Femtocell	145 145			
- http://www.ee.oulu.fi/~bennis/	79 79			
- http://cordis.europa.eu/fp7/ict/future-networks/projects_en.html	45 45			
- http://www.ict-freedom.eu	39 39			
- http://www.linkedin.com/groupAnswers	39 39			
- http://www.neclab.eu/Projects/BeFEMTO.htm	29 29			

Figure 3-29: BeFEMTO website visits, origin site (Year 2011)

Origin	Pages	Percent	Hits	Percent
Direct address / Bookmark / Link in email...	9492	67.9 %	10741	68.5 %
Links from an Internet Search Engine - Full list	3079	22 %	3165	20.2 %
- Google 3032 3116				
- Yahoo!	19 21			
- Unknown search engines	18 18			
- MyWebSearch	4 4			
- Ask	2 2			
- Digg (Social Bookmark)	1 1			
- Virgilio	1 1			
- AOL	1 1			
- Yandex	1 1			
Links from an external page (other web sites except search engines) - Full list	1379	9.8 %	1725	11 %
- http://en.wikipedia.org/wiki/LTE_Advanced	318 318			
- http://bi.qintra.com/strategyportal/default.aspx	183 183			
- http://en.wikipedia.org/wiki/4G	138 138			
- http://es.wikipedia.org/wiki/Long_Term_Evolution	81 81			
- http://www.ee.oulu.fi/~bennis/	57 57			
- http://en.wikipedia.org/wiki/Femtocell	40 40			
- http://es.wikipedia.org/wiki/LTE_Long_Term_Evolution	28 28			
- http://es.wikipedia.org/wiki/LTE_Advanced	26 26			
- http://femtoschool.cttc.es	26 26			
- http://cordis.europa.eu/fp7/ict/future-networks/projects_en.html	25 25			

Figure 3-30: BeFEMTO website visits, origin site (Year 2012, up to May)

Additionally, the Google ranking has become a good measure of the popularity of internet websites. By attaching specific keywords to the BeFEMTO website, it's achieved a good ranking in this popular search engine. For instance, typing “femto LTE-A”, or “evolved femtocell technologies”, the search engine will rank the BeFEMTO website in the first results positions. This is a good point to ensure that people around the world are able to access the project’s website by just typing some simple keywords related to BeFEMTO research.

3.2.8 Other dissemination channels

There are other dissemination channels in used to promote BeFEMTO project. During these months the project flyer has been uploaded in the website, and it has been created several links in internet.

3.2.8.1 Post-graduate courses

Based upon the topics of interest in WP3 and WP4 in BeFEMTO, UNIS initiated three PhD studies, at least one of these is expected to finish before the end of year. These are:

- Graph based Multi-cell Scheduling for Femto Networks
- Inter-Cell Interference Coordination in multi-cell HetNets
- Autonomous Coverage Estimation

Furthermore, UNIS added content related to femtocells in its 1-week long short course “Emerging Technologies in Mobile Communications” that it offers to industrial applicants for doing modular MSc. Additionally, UNIS contributed to preparing the lecture material for the winter school (that was primarily

aimed at PhD students) organized by BeFEMTO in Feb. 2012 and delivered lectures on following two topics:

- Cross-Layer Scheduling for Emerging Femto Broadband Systems
- A Unified View on Self-Organizing Techniques for Heterogeneous Networks

Thanks to its dissemination activities in BeFEMTO, UOulu has been invited to co-organize a number of IEEE workshops in Europe and America. In addition, a number of postgraduate courses have been organized around the themes of BeFEMTO, as well as our summer school.

3.2.8.2 Project Flyer

It is possible to download the BeFEMTO flyer from the home page of BeFEMTO.

3.2.8.3 Wikipedia

The link to the BeFEMTO website has been included in the Wikipedia (en), exactly in the terms:

1. 4G
2. LTE-Advanced
3. Femtocell

As it has been presented Figure 3-28 the presence of BeFEMTO in the wikipedia site has supposed to attract a considerable number of visitors to the BeFEMTO web page.

3.2.8.4 YouTube Channel

BeFEMTO has its own YouTube channel [57], where relevant videos related to the project (like training schools and testbeds demonstrations) have been uploaded to spread its achievements and knowledge.

<http://www.youtube.com/user/BeFEMTO/videos>

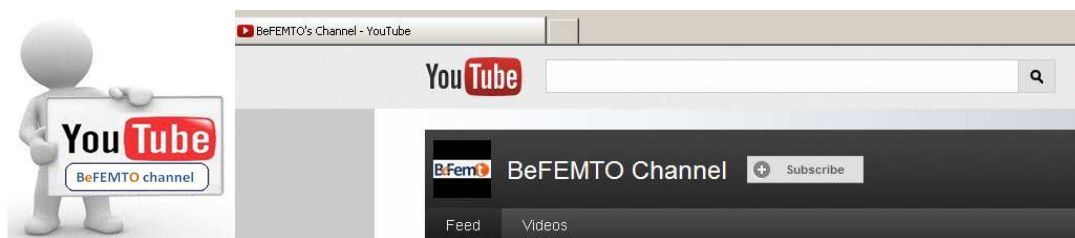

Figure 3-31: YouTube BeFEMTO Channel

“Mischa Dohler (CTTC) YouTube technology channel [58]” and “BeFEMTO YouTube channel” have allowed the dissemination of **21 videos** related to the presentation which took place during the winter school 2012 in CTTC in Barcelona, Spain.

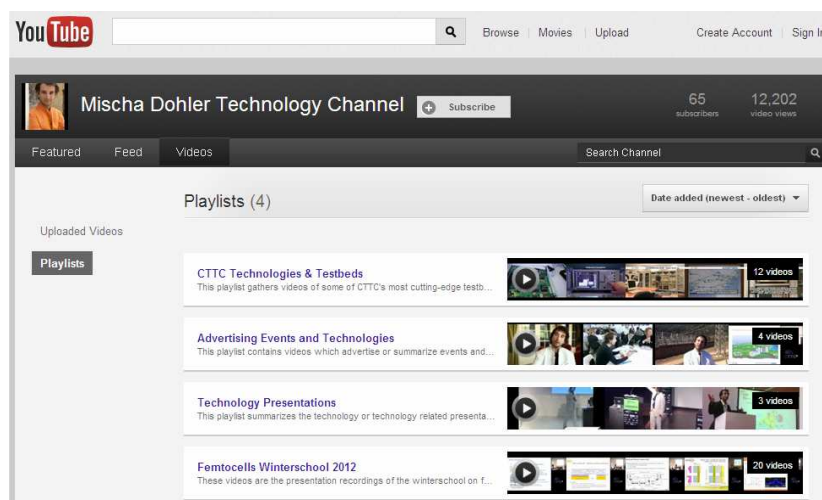

Figure 3-32: Mischa Dohler YouTube Channel (1975md)



Figure 3-33: BeFEMTO Winter School YouTube Videos

The 21 videos involved in the BeFEMTO Winter School are the following ones:

1. 01 BeFEMTO-Recent Trends in Femtocell Research.mp4
2. 02 BeFEMTO-Driving Drivers of the Femto Forum.mp4
3. 03 BeFEMTO-3GPP LTE Evolved Packet System Application to Femtos.mp4
4. 04 BeFEMTO-LTE A PHY Layer Overview Femto Design Challenges.mp4
5. 05 BeFEMTO-Femto LTE A Hardware Design Challenges.mp4
6. 06 BeFEMTO-Coverage Prediction for Heterogeneous Networks From Macrocells to Femtocells.mp4
7. 07 BeFEMTO-Analysis of K tier Heterogeneous Cellular Networks.mp4
8. 08 BeFEMTO-LTE -A Interference Coordination for Femtocells.mp4
9. 09 BeFEMTO-Interference Management in Co Channel Femtocell Deployment.mp4
10. 10 BeFEMTO-Distributed Interference Management in Femtocell Networks.mp4
11. 11 BeFEMTO-Cross Layer Scheduling for Emerging Broadband Femto Systems.mp4
12. 12 BeFEMTO-LTE-A SON for Femtocells.mp4
13. 13 BeFEMTO-Cognitive Docitive Femtocell Networks.mp4
14. 14 BeFEMTO-A Unified View on Self Organizing Techniques for Heterogeneous Networks Part1.mp4
15. 15 BeFEMTO-A Unified View on Self Organizing Techniques for Heterogeneous Networks Part2.mp4
16. 16 BeFEMTO-Energy-Efficient Mobility Management for the Integrated Macrocell-Femtocell LTE Network.mp4
17. 17 BeFEMTO-Overview of the BeFEMTO Networking Architecture.mp4
18. 18 BeFEMTO-Local Location Management in Networks of Femtocells.mp4
19. 19 BeFEMTO-Distributed Routing and Load Balancing in All Wireless Networks of Femtocells.mp4
20. 20 BeFEMTO-All Wireless Network of Femtocells Routing and Load Balancing in the NoF Testbed.mp4
21. 21 BeFEMTO 21 BeFEMTO-An Industrial Introduction to Femtocells.mp4

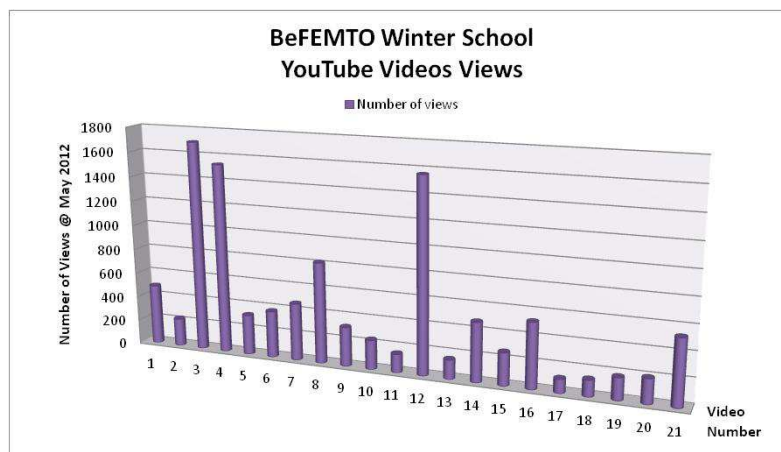

Figure 3-34: BeFEMTO Winter School YouTube Videos Views (@May 2012)

On the other hand, the testbeds performed during the project have been recorded and published in the BeFEMTO YouTube channel. All of them are uploaded as public ones in order to increase the visibility of the project. In the next figure is shown as example one of the testbed videos, related to testbed 3.

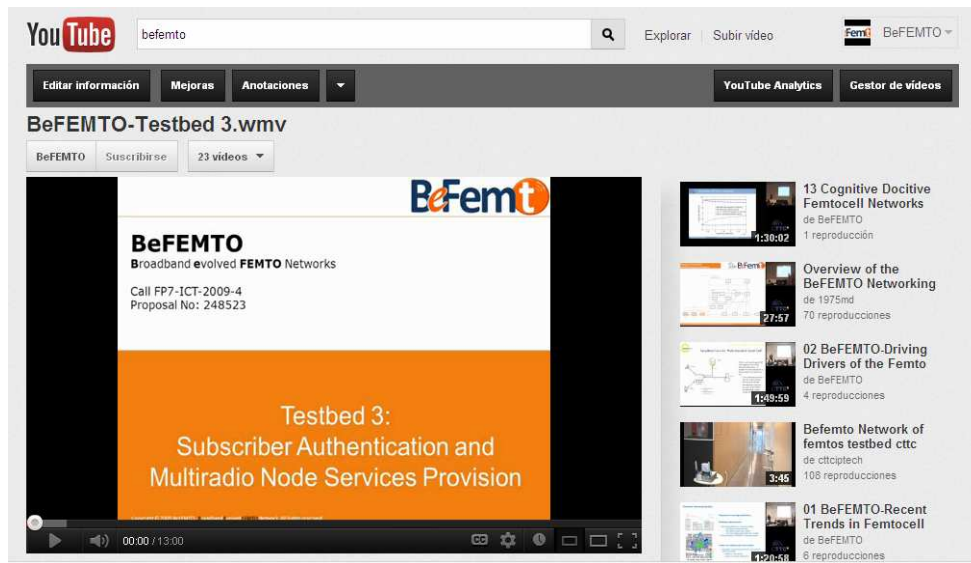

Figure 3-35: BeFEMTO Testbed3 YouTube Video

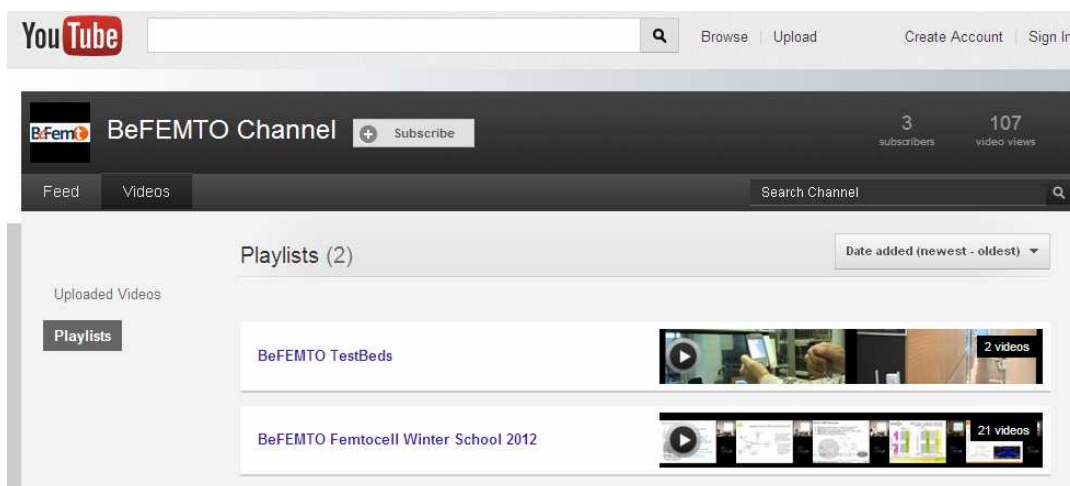

Figure 3-36: BeFEMTO YouTube Playlists

All the videos published in the channel include a link to the project webpage (<http://www.ict-befemto.eu/>)

3.2.8.5 LinkedIn

Other channel of dissemination used to spread the project activities and achievements is the BeFEMTO group created in the LinkedIn internet network. The webpage has a link to this group in [60].



Figure 3-37: BeFEMTO interest group in LinkedIn

Currently (end of May 2012) the group has **222 members subscribed**. The number of subscribers is growing every week from the beginning of the project and the discussions included in the group have interesting information exchange between members. Furthermore, this technical network is used to publicise the events involved in BeFEMTO project, like workshops, winter/summer schools, etc.

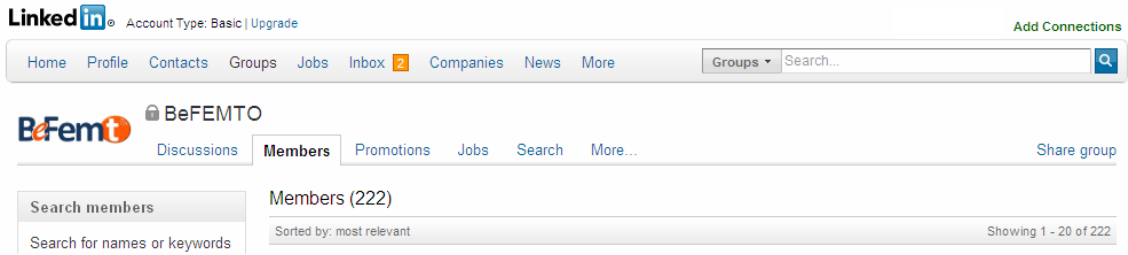

Figure 3-38: BeFEMTO group in LinkedIn

3.2.8.6 Polish National Contact Point for Research Programmes of the EU

Information on BeFEMTO project on the Polish NCP Webpage as a part of “Polish contribution to EU success in ICT” publication.

<https://intranet.kpk.gov.pl/app/registration/form.aspx?id=19&file=6937>

3.2.8.7 Other websites

In other FP7 projects like the Freedom project, there is a link to the BeFEMTO webpage, in the section called “Related projects”. BeFEMTO has included the link to the Freedom project in its website. Several synergies between both projects have been reached during the whole live of the project, including the co-organization of workshops and other activities presented before in this document.

Related projects

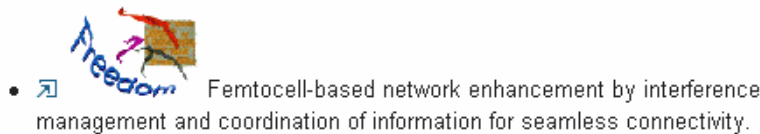

Figure 3-39: Link to Freedom project

3.2.8.8 Poster

The University of Surrey, UK has designed a poster (illustrated below) to promote and facilitate the dissemination of the BeFEMTO project. The poster is currently displayed at the premises of University of Surrey.

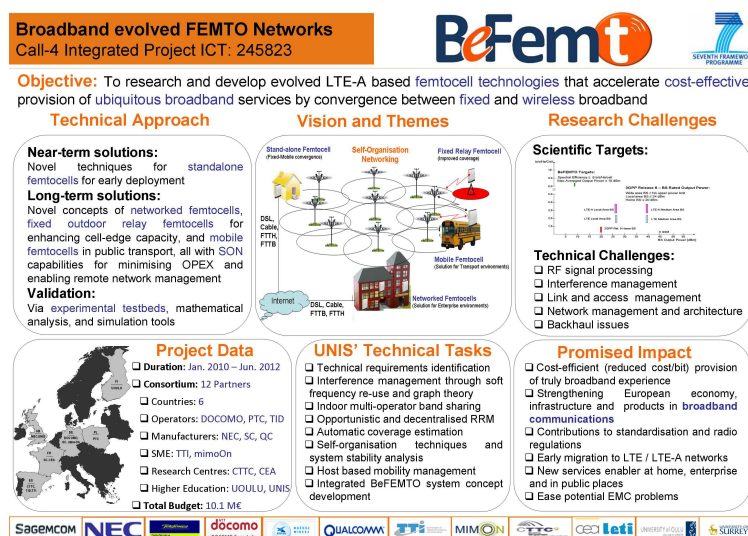

Figure 3-40: BEFEMTO poster

4. Management of Intellectual Property

4.1 LTE Patent status

During the year 2011, many strategic acquisitions by giant industry groups and conglomerates have been achieved, impacting the global LTE and 4G Market:

- Nortel patent Portfolio (+6000 patents) sold for \$4.5Billion,
- Motorola (+24000 patents) sold for \$12.5Billion



Figure 4-1 Mobile Communications Patents' Values

There is thus no doubt that generating patents is important for ensuring European Leadership & competitiveness, since patents filed to the European Patent Office (EPO) are still in minority compared with its counterparts in US (USPTO), or within the World Organization (WIPO), as illustrated in the Figure 4-2 below:

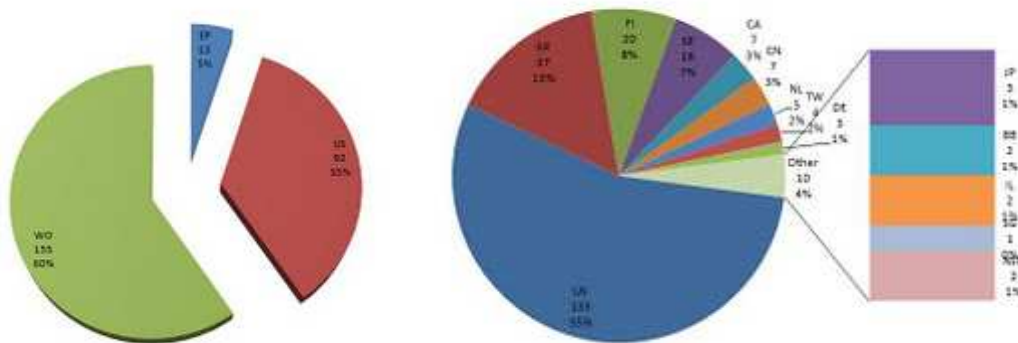

Figure 4-2 LTE-Advanced Global Patent Landscape by Patent Office (Left) and Assignee's Country (Right)

In addition to the approval procedures for documents, publications and standards contributions the management of knowledge is handled in the Grant Agreement, rule for participation and consortium agreement between the BeFEMTO partners. Simplified process has even been negotiated amongst partners, to facilitate Standard contributions, and allowing them to be mentioned in the project.

The management of intellectual property and other aspects of innovation in this project are debated when needed within the Board, thanks to crystal rules described in details in the signed Consortium Agreement, whilst framework and process are also available to all partners within the Management Handbook, that allow to explain the whole process with drawings and less formal legal language.

Information, and knowledge has been disseminated within the project and to external bodies with publications, presentations and to regulatory and standards bodies, but only after the necessary steps for ensuring the protection of IPRs have been made. This ensures that intellectual property will be secured in the interest of project partners. Contributions to external bodies have an impact on global harmonisation of concepts and systems. The dissemination of information and the influence, e.g. on standards bodies, are the prerequisites for the economic success of IPRs.

The management of such activities are also part of the mandates of the PM and the General Assembly. If required, the General Assembly will adjudicate on difficulties that are drawn to its attention related to knowledge management and associated matters.

Thanks to SDO's database, industry partners of the project are used to monitor competition, and interests in some working area of interest. As an example, some requests can be performed using the ETSI IPR Database: <http://ipr.etsi.org/>.

Of course, such work can never be exhaustive, since this requires too much resources non directly devoted to R&D development, but this is definitely useful whilst complementing the Standard strategy, and steering innovation direction throughout the whole project, during the down-selection of algorithms/mechanisms. However this process is too close to internal IPR policy & strategy of each partner, and can not be shared with many details.

4.2 BeFEMTO Follow-up

As already mentioned above, sharing details about patents filed by partners during the lifetime of the project is a very sensitive topic, since high worldwide competition, and thus resulting corporate policies usually do not allow this. Indeed, even getting information about a patent number can sometimes lead to objection process in preparation.

Hopefully, in BeFEMTO two (2) partners, namely mimoOn and Sagemcom (SC) accepted to disclose some of their patents (13) filed during the lifetime of the project, and related with their contribution to the project. This initiative is worth being underlined, especially from mimoOn: this SME claimed 11 patents initiated thanks to their contribution and participation in BeFEMTO.

N.B: The filing numbers have been shared under Confidential agreement with the European Commission as proof.

Another interesting aspect, comes from a simple 'follow-up' shared with partners during either General Assemblies, or Board Telcos. Indeed, by getting access to a professional IPR tool, Sagemcom made available some information, about key concepts pushed by some BeFEMTO partners in their patents related with Femtocells.

As an example, hereafter (Figure 4-3) the cluster map of concepts from Qualcomm's patents related with Femtocells. It's worth noticing most of Key concepts are well aligned with BeFEMTO area of investigations.

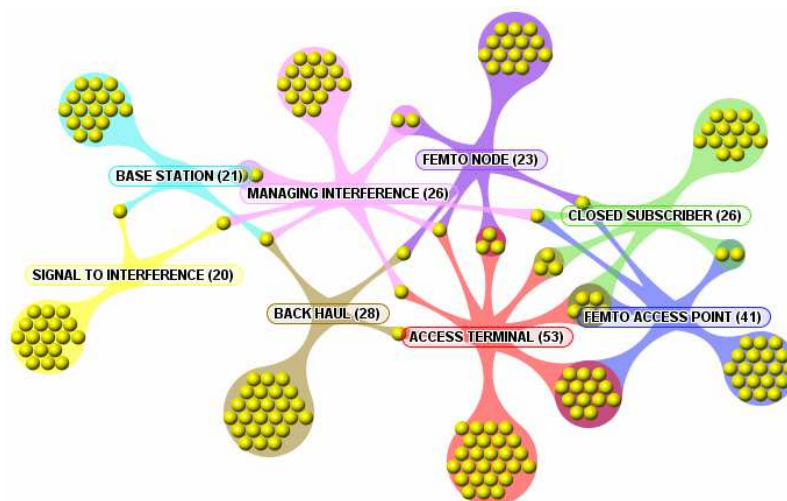

Figure 4-3 Qualcomm cluster of Concepts in Femtocells

Similarly, Figure 4-4 below highlights the Key concepts from NEC (Technical Manager) in the area of Femtocells:

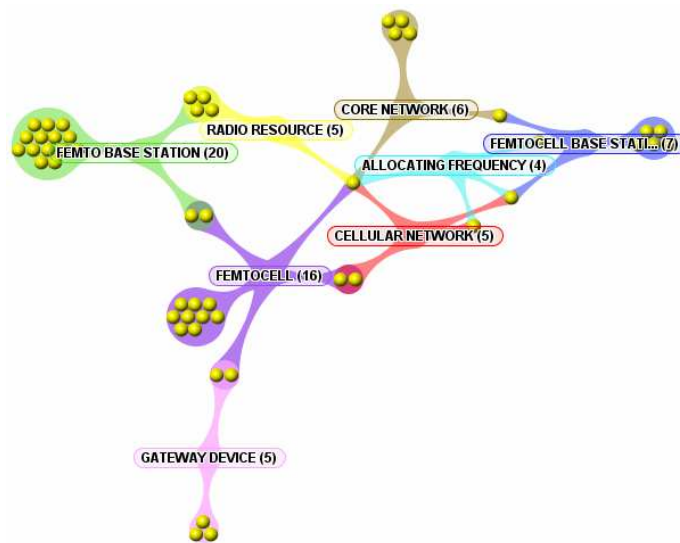

Figure 4-5 NEC Cluster of Concepts with Femtocells

Finally, by taking more industry partners into account within the patent search and analysis, the following results are obtained:

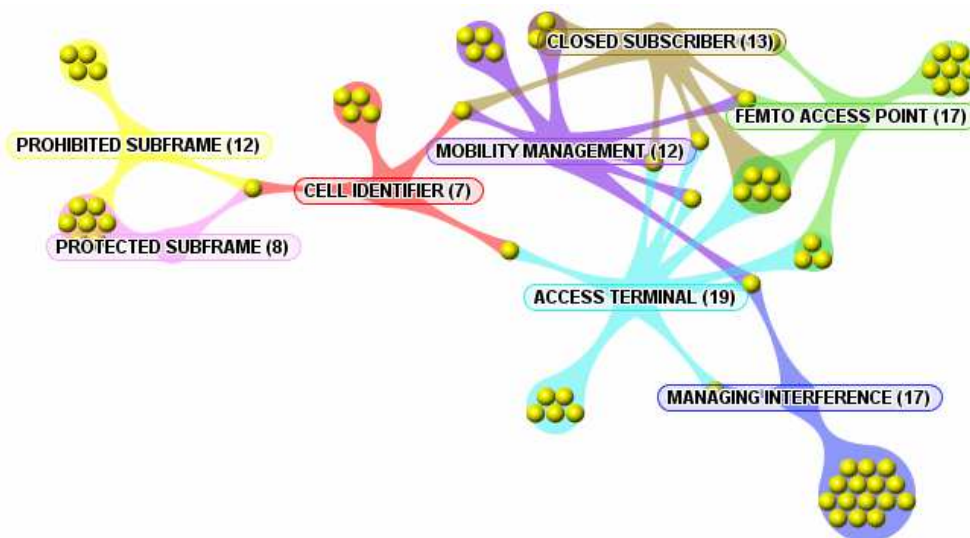

Figure 4-6 BeFemto industry partners: Clusters of Concepts

5. Exploitation plans

The detailed specific exploitation plans by individual partners in BeFEMTO are as follows.

5.1 Sagemcom (SC)

Sagemcom is a leading company for the development and deployment of femto access points in partnership with system integrators.

Sagemcom exploits BeFEMTO results in several ways for short terms to long terms internal projects:

- Product Validation: Sagemcom is using BeFEMTO’s test-beds as proof of concept for its 3G femtocell product and particularly for the validation of Iuh interface
- Product Development/Enhancement: similarly Sagemcom will validate some aspects of RRM algorithms that will be potentially included in future products (3G and LTE).

- LTE Task force: BeFEMTO allows Sagemcom to reinforce its internal advanced development program for LTE technology and mainly to strengthen the capacity of system level study that will be used for development of RRM algorithm for next LTE femtocell product.
- Customers' needs: Finally BeFEMTO helps Sagemcom to learn more about complete LTE femtocell system and understand operator's needs; as a consequence this will allow Sagemcom to bring more relevant answers to customer's requirements.
- IPR Generation: thanks to know-how strengthening, and innovation generated within the project, any opportunity to file relevant patents would be encouraged by our IPR Dept in order to secure this critical business line, and strengthen Sagemcom competitiveness.

5.2 NEC

NEC has used the knowledge gained within the BeFEMTO project to provide better consulting to its product strategy and product development units and for discussing potential technology transfer into prototypes/products. NEC has further established new contacts and deepened existing partnerships with customers and other vendors and exploited several marketing and collaboration opportunities. Its work within the project has also lead to several contributions within Small Cell Forum and 3GPP, in particular in 3GPP SA2 and its work item on LIPA Mobility and SIPTO at the Local Network (LIMONET). BeFEMTO results have been and will be exploited to further expand NEC's IPR profile. Several publications have been successfully submitted to and published in internationally reputed conferences, workshops and journals, strengthening NEC's visibility as provider of leading femtocell technology and solutions.

5.3 TID

Telefonica plans to use the knowledge acquired in the scope of the project in the definition of its network architectures, with the focus on provisioning novel wireless services. Other aspects quite relevant to Telefonica are the multiradio femtocells, as enablers of new services, the networked femtocells for enterprise and public spaces (malls, airports) and the relay femtocells, that improve cell border coverage, all of them could complement current Telefonica's stand-alone femtonodes deployments in Europe and South America. More specifically, the most important exploitation points for Telefónica are: Understand and analyze the new business models based on the project techno-economical results, improved network efficiency and management capabilities, for lower CAPEX and OPEX, , contributions to 3GPP and ETSI, integration of new network technologies and BeFEMTO deployment themes in Telefónica's infrastructure and identification of network requisites for the specification of future products, including future "Request for Information", and "Request for Quotation" processes. Among these exploitation options, Telefónica will focus in the standardization aspect, as it is the best driver to introduce functionalities in the networks and in the devices that could improve service performance and optimize costs. Telefónica is active in 3GPP RAN1 and RAN3 and in the next future will seek to introduce BeFEMTO findings in existing and new Working Items. The most appropriate current WI's for this purpose now are "Study on HetNet mobility enhancements for LTE" and "Further Self Optimizing Networks (SON) enhancement".

5.4 DOCOMO

First of all, DOCOMO Euro-Labs will exploit the new solutions towards innovative femto-cell deployments by integrating the results of the BeFEMTO project in its research and development activities. Key findings will impact DOCOMO Euro-Labs' 3GPP LTE-Advanced femto-cell and small cell standardization activities. Own standardization contributions for 3GPP LTE-Advanced are the main target.

Secondly, the project results will also contribute to a more efficient network operation with respect to throughput, coverage and flexibility of future mobile radio systems through the internal discussion with development and deployment sections of DOCOMO headquarters.

Finally, the dissemination activities of DOCOMO Euro-Labs also include several publications of key findings in the BeFEMTO project for international conferences and journals as well as in scientific fora and at workshops. Furthermore, DOCOMO plans to submit a few more papers as an extended study of the BeFEMTO project.

5.5 PTC

Over the last months or even years PTC has been testing the femtocell technology and considering the commercial Femto deployment.. Many consultations with the leading femtocell vendors have been carried out and PTC has executed two friendly user trials which included also integration of femtocell system with the PTC's network infrastructure.

By the end of 2011 PTC had deployed a number (about 30) of HNBs to improve 3G coverage in its shops. The company is still considering wider femtocell commercial deployment, but it seems so far there is not a strong business need yet to introduce femtocells on the Polish market.

However, having input from BeFEMTO project, PTC is still observing the femtocell evolution and is working on further steps toward a commercial femtocell launch, in the following aspects:

- specification of the user / operator requirements
- compliance of currently available solutions with the company existing network infrastructure
- business models, tariffs and concepts of future products involving femtocells.

In case PTC finally decides to commercially deploy the femtocell, the practical exploitation of the BeFEMTO results, especially from WP2 and WP5 working groups, will be considerably greater.

Of special interest to PTC, BeFEMTO studies which have not yet been implemented in commercial femtocell products such as networked femtocells, mobile femtocells, or new solutions for local femto gateway, definitely represent potential new opportunities.

5.6 Qualcomm (QC)

Qualcomm will further exploit all its findings that have been made within the BeFemto in its corporate R&D business unit. This includes that these results have been/will be also elaborated regarding its relevance for standardization and prototype/product development. This internal dissemination process ensured that also feedback from ongoing standardization activities to the BeFemto work topics was provided. Several standard contributions to 3GPP RAN3 for the 3GPP study item on mobile relays were submitted based on the BeFemto work. The generation of relevant IPR is most likely and has already happened in some areas. After internal exploitation of the results the key findings for interference management and positioning for femto cells have been published in international conferences. In addition, Qualcomm has been invited to several conferences as key note speaker promoting the findings in the area of interference management for femto & pico cells.

5.7 TTI

TTI as industrial partner will exploit the results of BeFEMTO on one hand to reinforce the internal capacities and on the other to keep the competitiveness of its products on the midterm by being on a lead position through innovation. The experience acquired along this project will provide TTI new competences and knowledge in RF equipments and their challenges for the promising mid-term market around LTE-A applications and Femtocell products. Moreover, the participation into BeFEMTO project will also help TTI to set up partnerships for new proposals with similar scope both in national and international initiatives. TTI plans to participate in the promotion of the results through the participation on workshops and scientific publications.

5.8 mimoOn

The mimoOn product portfolio covers LTE and LTE-Advanced SW for UE, Femtocell and Macro Basestations. The project results will be integrated in the mimoOn product feature portfolio:

- the projected mimoOn Femtocell intelligent scheduler,
- the mimoOn spatial interference management SW package,
- the mimoOn coordinated RRM SW package, and
- the mimoOn self-backhauling SW package.

mimoOn has driven the Scheduler API standardisation in FemtoForum, which is now adopted by FemtoForum and approved by all FemtoForum members.

The results of the BeFEMTO project will strengthen the mimoOn IP portfolio with key contributions in the area of SON, Femtocell interference management and RRM coordination.

The European scope of the project has brought together an excellent mix of partners covering all expertise to set major steps forward in this domain. The BeFEMTO project will be essential to move forwards and protect the competitive position of mimoOn.

5.9 CTTC

The CTTC, being a non-profit research institute, does not plan for a direct commercial exploitation of the project results stemming from BeFEMTO. However, CTTC's participation in this project is expected to stimulate a number of technology transfer and IPR generation activities which are at the core of its mission. From CTTC's participation in BeFEMTO, our staff will become more knowledgeable in a variety of technologies and systems such as LTE, LTE-A, femtocells, mesh networking, etc. Clearly, this will facilitate the establishment of new strategic partnerships with companies (network operators, equipment manufacturers, SMEs, etc), both at the national and international levels. These strategic alliances facilitate a bidirectional exchange of information on R&D trends and technological needs, access to labs and R&D equipment in favourable conditions, temporary hosting of R&D personnel, etc. Very often, today's strategic partnerships constitute the seed for tomorrow's industrial contracts which BeFEMTO is expected to stimulate, as well.

5.10 CEA

The BeFEMTO project has contributed to increase the know-how of the teams working on broadband wireless communication systems and 3GPP LTE and its evolutions. Results have been published in wide audience conferences. Another main objective of CEA-LETI in this project is to make a technology transfer covered by a license, which entitles partners to draw on CEA-LETI know-how and patents. In particular, CEA-LETI has developed a system level simulator, which is being continually enriched, through participation to various projects. In BEFEMTO, femto-cell deployment has been added to this simulator. One of CEA-LETI goal is to exploit this simulator in the context of contracts with industrial partners.

5.11 University of Oulu (UOULU)

University of Oulu plans to use the results of BeFEMTO project in national government funded projects in co-operation with industrial partners. In addition, we will be organizing a summer school with a special emphasis on femtocell networks where both MSc, PhD students and researchers from both academia and industry will be targeted. We will also provide PhD level training courses reflecting the scientific achievements of the project which will shape up short and long term research projects. Finally, we will be publishing in top-level conference and journal papers, as well as book chapters to further disseminate BeFEMTO results.

5.12 University of Surrey (UNIS)

University of Surrey (UniS) is and will be publishing BeFEMTO results in top ranked journals and conferences. Furthermore, UniS will organise special workshops on femtocells technology in top reputed conferences. It is expected that the knowledge created by BeFEMTO project will be used to enhance the lecture materials for both undergraduate and postgraduate courses, and also for identifying new research challenges for the future and ongoing MSc and PhD projects.

6. Conclusions

This document reports the dissemination and standardization activities carried out during the whole lifetime of the BeFEMTO project.

With respect to standardization, this deliverable indicates which partners attended to the various relevant standardization groups, which are the relevant working groups and work items, and a mapping between them and the activities in the BeFEMTO work packages and tasks. As a result of the standardization efforts in the project, a total of **27 contributions** have been submitted to 3GPP, Small Cell Forum and ETSI, discussing BeFEMTO concepts related to interference coordination and local mobility management among HeNBs, SON for HeNBs, Enterprise Femtocell architecture as well as multi-radio femtocell nodes.

Regarding dissemination, the consortium has presented **59 scientific papers** with results of the BeFEMTO research at a number of prestigious international conferences and workshops, such as IEEE VTC 2010 and 2011, FuNEMS 2010 and 2011, IEEE PIMRC 2010 and 2011, IEEE GLOBECOM 2010 and 2011, IEEE ASILOMAR, IEEE WCNC 2011 and 2012, WIRELESS VITAE 2011, IEEE ICC 2011 and 2012, IEEE ANTS 2011, IEEE CCNC 2012, IEEE Wiopt 2012, W-GREEN workshop, Indoor Outdoor Femto Cells (IOFC) workshop, etc. Additionally, the project has presented **10 articles in international journals and magazines**, **2 Journals' special issues** and has attended **several events** where the project goals and scientific knowledge have been presented. On the other hand, BeFEMTO has organized **5 international workshops** at VTC Spring 2011, FuNEMS 2011, WCNC 2012, ICC 2012 and ICCCN 2012. These workshops have included paper presentations, talks by international keynote speakers and **panel discussions** on evolved femtocell technologies with high interest to both scientific and industry communities. BeFEMTO academic partners have organized **two international training schools**: one winter school in Barcelona (Spain) in collaboration with other European project, and one summer school in Oulu (Finland). One **panel session** has been carried out in the PIMRC 2011 conference in Toronto (Canada). BeFEMTO partners have attended to several events where the project goals, partners and scientific knowledge have been described by means of **23 presentations**. Finally, a comprehensive list of dissemination channels: scientific publications, presentations at events, also including social/technical networks, and video storage tools, for the dissemination of BeFEMTO results have been identified and used to spread the project knowledge and achievements. The edition of **two books** related to the topics of BeFEMTO is been planned for the second half of 2012, and on the other hand the BeFEMTO project has contributed to the **edition of chapters in four books**.

Finally, in order to provide a single point for coordination of the BeFEMTO standardization and dissemination contribution, Work Package 7 established the necessary infrastructure on the BeFEMTO server, composed of dissemination and standardization plans and the corresponding registers for the effective results. All partners can consult the standardization/dissemination plans and registers to identify opportunities and synergies across the whole project.

7. References

- [1] COPRAS Generic guidelines for IST research projects interfacing with ICT standards organizations”, July 2005
- [2] RP-100671, New Study Item Proposal: Signaling and procedure for in-device coexistence interference avoidance, June 2010.
- [3] [Online] BeFEMTO Linkedin group: <http://www.linkedin.com/groups?home=&gid=2462391>
- [4] [Online] 2010 IEEE 71st Vehicular Technology Conference: <http://www.ieeevtc.org/vtc2010spring>
- [5] [Online] Future Network and Mobile Summit 2010: <http://www.futurenetworksummit.eu/2010>
- [6] [Online] The 21st Annual IEEE International Symposium on Personal, Indoor and Mobile Radio Communications: <http://www.ieee-pimrc.org>
- [7] [Online] The Asilomar Conference on Signals, Systems and Computers: <http://www.asilomarssc.org/>
- [8] [Online] IEEE Global Communications Conference: <http://www.ieee-globecom.org/2010/>
- [9] [Online] 2nd International Conference on Wireless Communications, Vehicular Technology, Information Theory and Aerospace & Electronic System Technology: <http://www.wirelessvitaechennai.org>
- [10] [Online] <http://www.wns3.org/2011/General/General>
- [11] [Online] <http://www.ieee-wcnc.org/>
- [12] [Online] <http://iofc-workshop2011.bell-labs.fr/>
- [13] [Online] <http://www.ieeevtc.org/vtc2011spring/workshops.php#BeFemto>
- [14] [Online] <http://www.ieee-icc.org/>
- [15] [Online] <http://www.futurenetworksummit.eu/2011/>
- [16] [Online] <http://www.wireless-days.org/>
- [17] [Online] <http://netgcoop.imag.fr/>
- [18] [Online] <http://www2.ing.unipi.it/meshtech11/>
- [19] [Online] <http://www.isabelconference.com/index.php?page=cogart>
- [20] [Online] <http://www.ti.rwth-aachen.de/iswcs2011/>
- [21] [Online] <http://www.ieee-globecom.org/>
- [22] [Online] <http://www.ieee-comsoc-ants.org/index.html>
- [23] [Online] <http://www.ieee-ccnc.org/>
- [24] [Online] <http://www.ieee-wcnc.org>
- [25] [Online] <http://www.wi-opt.org/>
- [26] [Online] <http://www.ieee-icc.org/>

-
- [27] [Online] <http://www.icl-gnss.org/2012/index.php>
- [28] [Online] <http://www.ieeevtc.org/vtc2012fall/>
- [29] [Online] <http://www.ieee-pimrc.org/>
- [30] [Online] Connect World Magazine: [http://www.connect-world.com/articles/recent_article.php?oid=Europe I 2010 08](http://www.connect-world.com/articles/recent_article.php?oid=Europe_I_2010_08)
- [31] [Online] Computer Communications Journal: http://www.elsevier.com/wps/find/journaldescription.cws_home/525440/bibliographic
- [32] [Online] IEEE ComSoc MMTC E-Letters Journal: <http://committees.comsoc.org/mmc/e-news/E-Letter-September10.pdf>
- [33] [Online] <http://dl.comsoc.org/surveys>
- [34] [Online] <http://www.jsac.ucsd.edu/>
- [35] [Online] <http://dl.comsoc.org/twc/>
- [36] [Online] Future Networks 5th FP7 Concertation Plenary Meeting: Call 4 Projects": http://ec.europa.eu/information_society/events/cf/fnc5/item-display.cfm?id=2692
- [37] [Online] Femto Forum: <http://www.femtoforum.org/femto/>
- [38] [Online] Centre for Wireless Network Design: <http://www.cwind.org/femtocellworkshop>
- [39] [Online] 3rd Japan-EU Symposium on the "New Generation Network" and the "Future Internet" <http://www.ict-fireworks.eu/events/other-events/eu-japan-event.html>
- [40] [Online] <http://www.futureinternet-internetdufutur.nrc-cnrc.gc.ca/eng/index.html>
- [41] [Online] <http://gdr-isis.fr/index.php?page=reunion&idreunion=133>
- [42] [Online] <http://www.wireless-advanced2011.org/>
- [43] [Online] <http://leti.congres-scientifique.com/annualreview2011/>
- [44] [Online] <http://acts.ing.uniroma1.it/IC0902/SummerSchool2011/Home.html>
- [45] [Online] BeFEMTO Winter School Website: <http://femtoschool.cttc.es/>
- [46] [Online] <http://www.cwind.org/femtocell2012/>
- [47] [Online] IEEE Vehicular Technology Conference Workshops: <http://www.ieeevtc.org/vtc2011spring/workshops.php>
- [48] [Online] Future Network & Mobile Summit 2011: <http://www.futurenetworksummit.eu/2011/>
- [49] [Online] <http://www.ieee-wcnc.org/2012/>
- [50] [Online] <http://www.cwc oulu.fi/smallnets/>
- [51] [Online] Freedom Project Website: <http://www.ict-freedom.eu/>
- [52] [Online] BeFEMTO Project Website: <http://www.ict-BeFEMTO.eu>.
- [53] [Online] BeFEMTO Summer School Website: <http://www.cwc oulu.fi/summerschool2011/>

-
- [54] [Online] IEEE International Symposium on Information Theory: http://www.isit2011.org/symp_invitation.php
- [55] [Online] Earth Project Website: <https://www.ict-earth.eu/>
- [56] [Online] GreenNet: <http://www.fp7-greenet.eu/default.php>
- [57] [Online] BeFEMTO YouTube channel: <http://www.youtube.com/user/befemto>
- [58] [Online] Mischa Dohler YouTube channel: <http://www.youtube.com/user/1975md>
- [59] [Online] <http://www.dmoz.org/add.html>
- [60] [Online] <http://www.ict-BeFEMTO.eu/about-us.html>